

DI & DM SERIES SPST STANDARD DIP SWITCHES

FEATURES

High reliability.
Self-cleaning contacts.
Multi- positions.
Process compatible with tape seal.
Dual in-line .100" x .300" term. spacing.

SPECIFICATIONS SUBJECT TO CHANGE WITHOUT NOTICE.

GENERAL SPECIFICATIONS

ELECTRICALS

Electrical life	2000 cycles min. per switch @ 24 VDC, 25 mA
Contact rating, non-switching	100 mA at 50 VDC
Contact rating, switching	25 mA at 24 VDC
Contact resistance at current 100 mA	50 m Ω max. initial - 100 m Ω max. after life test
Insulation resistance at 100 VDC	100 M Ω minimum
Dielectric strength	500 VAC for 1 minute
Capacitance	5 pf. max. between adjacent terminals

MECHANICALS, THERMALS

Mechanical life	2000 cycles min. per switch
Operating force	1000 grams max.
Vibration	10-55 Hz. per MIL-STD-202F METHOD 201A
Shock	50 G (peak value) for 11 msec. per MIL-STD-202F, METHOD 213B
Operating temperature range	-40°C to 85°C

SOLDERING & CLEANING RECOMMENDATIONS*

Hand soldering	320°C max. for 2 seconds max. (30 watt iron max.)
Wave soldering	260°C max. for 5 seconds max.
Cleaning (with tape seal)	Spray wash from top side only.

* Note: keep switches in "OFF" position during soldering and cleaning for best results

MATERIALS

Base & Cover	DI: UL94V-O, glass fiber filled PBT, black DM: UL94V-O, glass fiber filled PPS, black
Actuators	UL94V-O, Nylon, white
Contacts	Gold over nickel plated copper alloy
Terminals	DI: Tin/lead plated brass. DM: Gold over nickel plated copper alloy.
Term. Sealing	Molded-in
Tape seal	Kapton

PACKAGING

DIP switches are shipped in standard IC tubes with all actuators in the "OFF" position.
Tape & reel packaging per EIA available for DMR models (see next page).

SWITCH CROSS SECTIONS

Double
contact system

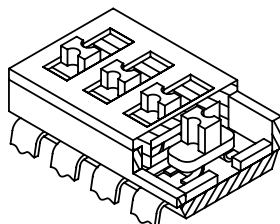

DI & DM

SCHEMATIC (TYPICAL)

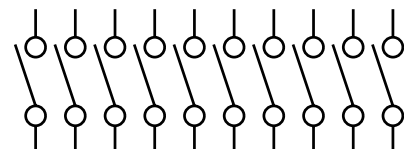

See tabulations on following pages for
number of positions available (10 shown)

**DI Series
Machine
Insertable ρ**



Tin/lead plated brass terminals
Gold plated terminals available on request

Actuator	Squared terminals		Spread terminals		No. of Pos.	'A' Dim. +.008/-0.000" (+0.2/-0.0mm)
	MODEL NO. with no tape seal	MODEL NO. with tape seal	MODEL NO. with no tape seal	MODEL NO. with tape seal		
Raised	DI01H	n/a	DI01S	n/a	1	.137 (3,48)
	DI02H	n/a	DI02S	n/a	2	.237 (6,02)
	DI04H	n/a	DI04S	n/a	4	.437 (11,10)
	DI06H	n/a	DI06S	n/a	6	.637 (16,18)
	DI08H	n/a	DI08S	n/a	8	.837 (21,26)
Recessed	DI10H	n/a	DI10S	n/a	10	1.037 (26,34)
	DIR01H	n/a	DIR01S	DIR01ST	1	.137 (3,48)
	DIR02H	DIR02HT	DIR02S	DIR02ST	2	.237 (6,02)
	DIR04H	DIR04HT	DIR04S	DIR04ST	4	.437 (11,10)
	DIR06H	DIR06HT	DIR06S	DIR06ST	6	.637 (16,18)
	DIR08H	DIR08HT	DIR08S	DIR08ST	8	.837 (21,26)
	DIR10H	DIR10HT	DIR10S	DIR10ST	10	1.037 (26,34)

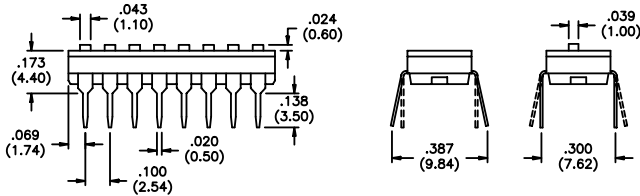
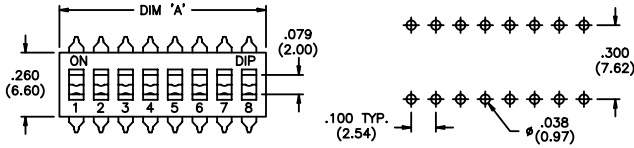

ρ Auto-insertable using equipment from Amistar, Dynapert, Panasert, Northeastern Tool, Universal and others.

n/a = not available.

SPECIFICATIONS SUBJECT TO CHANGE WITHOUT NOTICE.

P

**DM Series
Surface
Mount ρ**



Actuator Style	MODEL NO. with no tape seal	MODEL NO. with tape seal	No. of Pos.	'A' Dimension +.008/-0.000" (+0.2/-0.0mm)
Raised Actuator	DM01	n/a	1	.137 (3,48)
	DM02	n/a	2	.237 (6,02)
	DM03	n/a	3	.337 (8,56)
	DM04	n/a	4	.437 (11,10)
	DM05	n/a	5	.537 (13,64)
	DM06	n/a	6	.637 (16,18)
	DM07	n/a	7	.737 (18,72)
	DM08	n/a	8	.837 (21,26)
	DM09	n/a	9	.937 (23,80)
	DM10	n/a	10	1.037 (26,34)
	DM12	n/a	12	1.237 (31,42)
	Recessed Actuator	DMR01	n/a	1
DMR02		DMR02T	2	.237 (6,02)
DMR03		DMR03T	3	.337 (8,56)
DMR04		DMR04T	4	.437 (11,10)
DMR05		DMR05T	5	.537 (13,64)
DMR06		DMR06T	6	.637 (16,18)
DMR07		DMR07T	7	.737 (18,72)
DMR08		DMR08T	8	.837 (21,26)
DMR09		DMR09T	9	.937 (23,80)
DMR10		DMR10T	10	1.037 (26,34)
DMR12		DMR12T	12	1.237 (31,42)

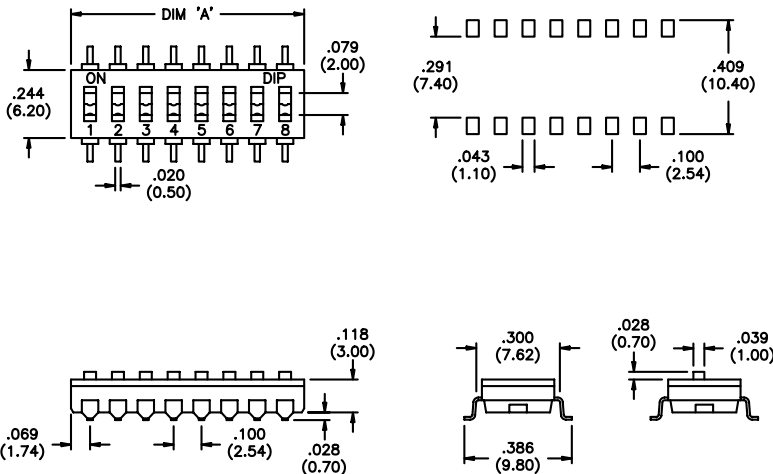

For tape & reel packaging on DMR models only, add 'TR' to model number - example: DMR08TTR. Note- tape & reel packaging is available only with tape seal models. 900 switches per reel.



Компания «ЭлектроПласт» предлагает заключение долгосрочных отношений при поставках импортных электронных компонентов на взаимовыгодных условиях!

Наши преимущества:

- Оперативные поставки широкого спектра электронных компонентов отечественного и импортного производства напрямую от производителей и с крупнейших мировых складов;
- Поставка более 17-ти миллионов наименований электронных компонентов;
- Поставка сложных, дефицитных, либо снятых с производства позиций;
- Оперативные сроки поставки под заказ (от 5 рабочих дней);
- Экспресс доставка в любую точку России;
- Техническая поддержка проекта, помощь в подборе аналогов, поставка прототипов;
- Система менеджмента качества сертифицирована по Международному стандарту ISO 9001;
- Лицензия ФСБ на осуществление работ с использованием сведений, составляющих государственную тайну;
- Поставка специализированных компонентов (Xilinx, Altera, Analog Devices, Intersil, Interpoint, Microsemi, Aeroflex, Peregrine, Syfer, Eurofarad, Texas Instrument, Miteq, Cobham, E2V, MA-COM, Hittite, Mini-Circuits, General Dynamics и др.);

Помимо этого, одним из направлений компании «ЭлектроПласт» является направление «Источники питания». Мы предлагаем Вам помощь Конструкторского отдела:

- Подбор оптимального решения, техническое обоснование при выборе компонента;
- Подбор аналогов;
- Консультации по применению компонента;
- Поставка образцов и прототипов;
- Техническая поддержка проекта;
- Защита от снятия компонента с производства.



Как с нами связаться

Телефон: 8 (812) 309 58 32 (многоканальный)

Факс: 8 (812) 320-02-42

Электронная почта: org@eplast1.ru

Адрес: 198099, г. Санкт-Петербург, ул. Калинина, дом 2, корпус 4, литера А.