



5 to 8 Ethernet ports RJ45, FOC, and PoE / PoE+
 Unmanaged Plug and Play Ethernet switches for DIN rail assembly in control cabinets
 Commercial temp.: 0 °C ... +55 °C / Industrial temp.: -40 °C ... +70 °C



- Energy supply of up to 4 terminal devices via PoE+ (137 watts) in accordance with IEEE 802.3at
- Fast Ethernet Non-Blocking Switch architecture in accordance with IEEE 802.3
- Variants with industrial temperature range of -40 °C ... +70 °C
- Surge protection and reverse polarity protection
- Minimum energy consumption due to energy-efficient Ethernet
- Optimised DIN rail bracket

Target markets

Machinery & Robotics	Automation	Industrial network infrastructures
Wind Energy, Solar Energy	Transportation	Shipbuilding



General description

The Ha-VIS eCon 3000 Fast Ethernet PoE family of unmanaged Ethernet switches is equipped with up to 8 Fast Ethernet ports and allow for cost-efficient and quick expansion and/or reconstruction of network infrastructures. The switches work as power sourcing equipment (PSE) and are capable of simultaneously providing the full PoE output of 34.2 watts on up to four ports. The slender design of the switches enables

an extremely high packing density on the DIN rail. The selection includes various combinations of variants with RJ45 and fibre optic ports. Automatic detection of the transmission rate (auto-negotiation) and of the wiring of the twisted pair data cable (auto-polarity and auto-MDI(X)) allow for simple plug and play. All variants are available with the temperature ranges "Industrial" and "Commercial".

Technical characteristics

Switch features

Enclosure width	25 mm
Number of ports	5, 6, 7, 8
Switching technology	Store and Forward
Supported standards	IEEE 802.3
Frame size	1522 bytes
MAC table size	1k entries
Packet buffer size	448 kbit
Non-blocking	Yes
Quality of Service	Yes
Energy-efficient Ethernet	Yes
PROFINET-compatible	Yes
EthernetIP-compatible	Yes

Power supply

Nominal voltage	24 VDC ☐☐☐	48 VDC ☐☐☐	54 VDC ☐☐☐
Permissible voltage range	9 VDC ... 60 VDC ☐☐☐		
Surge protection	Yes		
Reverse polarity proof	Yes		
Starting current	3.20 A	6.40 A	7.20 A
Overcurrent protection at input	Yes (12 A)		
Max. power consumption @ 24 VDC	1.92 W ... 3.60 W		
Conductor cross-section	0.08 mm ² ... 2.5 mm ² (28 AWG ... 12 AWG)		
Type of connection	3-pole, pluggable screw type terminal block		
Pinout	+ / - / ⚡		
Supply circuit (according to 60950)	SELV (circuit breaker 10 A)		

Ethernet ports 10BASE-T_e / 100BASE-TX

Type of connection	RJ45
Auto-negotiation	Yes
Auto-polarity	Yes
Auto-MDI(X)	Yes
Transfer conditions	Twisted pair
Transfer speed	10 / 100 Mbit/s
Transfer length	100 m (Twisted Pair, Cat 5)

Ethernet ports 100BASE-FX

Type of fibre	Multi-mode (MM)	Single-mode (SM)
Type of connection	SC Duplex	
Transfer conditions	FOC	
Wavelength	1310 nm	
Transfer speed	100 Mbit/s	
Transfer length	2 km	15 km
Output power	-20 dBm ... -14 dBm	-15 dBm ... -8 dBm
Input sensitivity	≤ -30 dBm	≤ -32 dBm

Environmental conditions

Commercial temperature range	0 °C ... +55 °C
Industrial temperature range	-40 °C ... +70 °C
Storage temperature range	-40 °C ... +85 °C
Relative humidity (operation)	0% ... 95% (non-condensing)
Relative humidity (storage and transport)	0% ... 95% (non-condensing)
Air pressure	2000 m (795 hPa)



HARTING Technology Group
 P.O.Box 1473, D-32325 Espelkamp
 Wilhelm-Harting-Straße 1, D-32325 Espelkamp, Germany

ICPN-Service@harting.com | Service hotline: +49 5772 47-9479
 Fax: +49 5772 47-495 | www.HARTING.com/de/ethernet-switches

Note: We reserve the right to make technical changes to the products and to the content of this document at any time without prior notification. The HARTING Technologiegruppe does not accept any responsibility for possible errors or incompleteness in this document. We reserve all the rights to this document and the topics and illustrations contained within it. Copying, disclosure to third parties or use of its content - even partially - is forbidden without the prior written consent of the HARTING Technologiegruppe.

PoE

Number of PoE ports	4	
Standard	IEEE 802.3af / IEEE 802.3at	
PoE type	PSE	
Supported mode	Alternative A	
Power supply PSE	48 VDC ---	54 VDC ---
Maximum power consumption PSE	1380 mA	2380 mA
Maximum current (PoE / PoE+)	375 mA	638 mA
Maximum output power PSE	15.4 W per port 61.6 W total	34.2 W per port 136.8 W total
Supported cabling	See 802.3at, section 33.1.4	
PoE pinout	Alternative A, MDI-X (1/2 = V-, 3/6 = V+)	

Status and diagnostic displays

Power ("Pwr") illuminated green	Supply voltage is applied
Link/Activity ("L/A") off	No link
Link/Activity ("L/A") illuminated green	Link is active
Link/Activity ("L/A") flashes green	Link is active and data is transferred
Link speed ("Spd") off	10 Mbit/s
Link speed ("Spd") illuminated yellow	100 Mbit/s
PoE status off	PoE is inactive / low voltage
PoE status illuminated green	Voltage in PoE range
PoE status illuminated blue	Voltage in PoE+ range
PoE status illuminated red	Fault

Enclosures

Enclosure width	25 mm
Dimensions H x W x D (without pluggable screw type terminal block and holding bracket)	142 mm x 25 mm x 107.5 mm
Weight	480 g ... 508 g
Type of installation	35 mm DIN rail acc. to EN 60 715
Material enclosures	Anodised aluminium / powder-coated steel sheet
Protection class (with pluggable screw type terminal block)	IP30
Protection class	III

Approvals

CE, FCC CFR 47 Part 15, cJUL US 508 listed, DNV, GL, ABS, NK, ABB IIT

EMC and environmental conditions

EMC interference immunity (EN 61000-6-1, 61 000-6-2 55024)

Electrostatic discharge (ESD) EN 61 000-4-2
 Electromagnetic field EN 61 000-4-3
 Rapid transients (burst) EN 61 000-4-4
 Surge voltages EN 61 000-4-5 Conducted interference voltages EN 61 000-4-6

EMC interference emission (EN 61000-6-4, EN 55 022, FCC CFR 47 Part 15)

Mechanical stability (EN 60721-3)

IEC 60068-2-6 Vibration
 IEC 60068-2-6 Resonance search
 IEC 60068-2-27 Shock test

Included delivery

- Pluggable screw type terminal block for power supply
- Installation instructions

Drawings

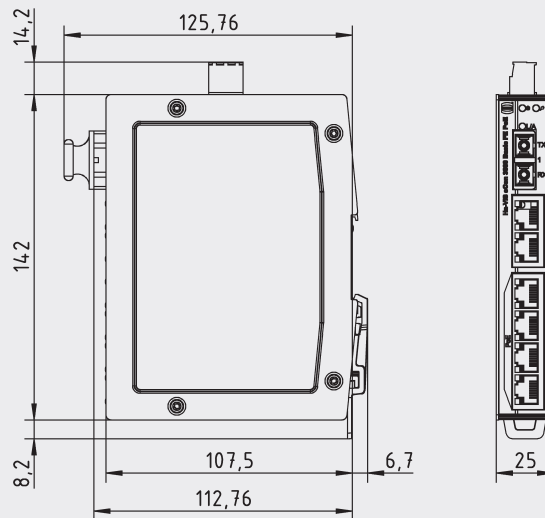

Technical characteristics / order information

Ports / order information

RJ45	SFP	SC	Enclosure width	Power consumption @ 24 VDC without PoE	MTBF in million h	Commercial temp.: 0 °C ... +55 °C		Industrial temp.: -40 °C ... +70 °C	
						Switch	Part no.	Switch	Part no.
4	-	1x MM (2 km)	25 mm	0.12 A	1.19	Ha-VIS eCon 3041B-AD-P	24 03 004 1130	Ha-VIS eCon 3041BT-AD-P	24 03 004 1120
4	-	1x SM (15 km)	25 mm	0.12 A	1.19	Ha-VIS eCon 3041B-AF-P	24 03 004 1230	Ha-VIS eCon 3041BT-AF-P	24 03 004 1220
4	-	2x MM (2 km)	25 mm	0.15 A	1.17	Ha-VIS eCon 3042B-AD-P	24 03 004 2130	Ha-VIS eCon 3042BT-AD-P	24 03 004 2120
4	-	2x SM (15 km)	25 mm	0.15 A	1.17	Ha-VIS eCon 3042B-AF-P	24 03 004 2230	Ha-VIS eCon 3042BT-AF-P	24 03 004 2220
6	-	-	25 mm	0.08 A	1.18	Ha-VIS eCon 3060B-A-P	24 03 006 0030	Ha-VIS eCon 3060BT-A-P	24 03 006 0020
6	-	1x MM (2 km)	25 mm	0.13 A	1.15	Ha-VIS eCon 3061B-AD-P	24 03 006 1130	Ha-VIS eCon 3061BT-AD-P	24 03 006 1120
6	-	1x SM (15 km)	25 mm	0.13 A	1.15	Ha-VIS eCon 3061B-AF-P	24 03 006 1230	Ha-VIS eCon 3061BT-AF-P	24 03 006 1220
8	-	-	25 mm	0.09 A	1.14	Ha-VIS eCon 3080B-A-P	24 03 008 0030	Ha-VIS eCon 3080BT-A-P	24 03 008 0020



Компания «ЭлектроПласт» предлагает заключение долгосрочных отношений при поставках импортных электронных компонентов на взаимовыгодных условиях!

Наши преимущества:

- Оперативные поставки широкого спектра электронных компонентов отечественного и импортного производства напрямую от производителей и с крупнейших мировых складов;
- Поставка более 17-ти миллионов наименований электронных компонентов;
- Поставка сложных, дефицитных, либо снятых с производства позиций;
- Оперативные сроки поставки под заказ (от 5 рабочих дней);
- Экспресс доставка в любую точку России;
- Техническая поддержка проекта, помощь в подборе аналогов, поставка прототипов;
- Система менеджмента качества сертифицирована по Международному стандарту ISO 9001;
- Лицензия ФСБ на осуществление работ с использованием сведений, составляющих государственную тайну;
- Поставка специализированных компонентов (Xilinx, Altera, Analog Devices, Intersil, Interpoint, Microsemi, Aeroflex, Peregrine, Syfer, Eurofarad, Texas Instrument, Miteq, Cobham, E2V, MA-COM, Hittite, Mini-Circuits, General Dynamics и др.);

Помимо этого, одним из направлений компании «ЭлектроПласт» является направление «Источники питания». Мы предлагаем Вам помощь Конструкторского отдела:

- Подбор оптимального решения, техническое обоснование при выборе компонента;
- Подбор аналогов;
- Консультации по применению компонента;
- Поставка образцов и прототипов;
- Техническая поддержка проекта;
- Защита от снятия компонента с производства.



Как с нами связаться

Телефон: 8 (812) 309 58 32 (многоканальный)

Факс: 8 (812) 320-02-42

Электронная почта: org@eplast1.ru

Адрес: 198099, г. Санкт-Петербург, ул. Калинина, дом 2, корпус 4, литера А.