

**NEW**  



Docking Connector Compatible with PCI Express

CONNECTOR

MB-0200-1

March 2009

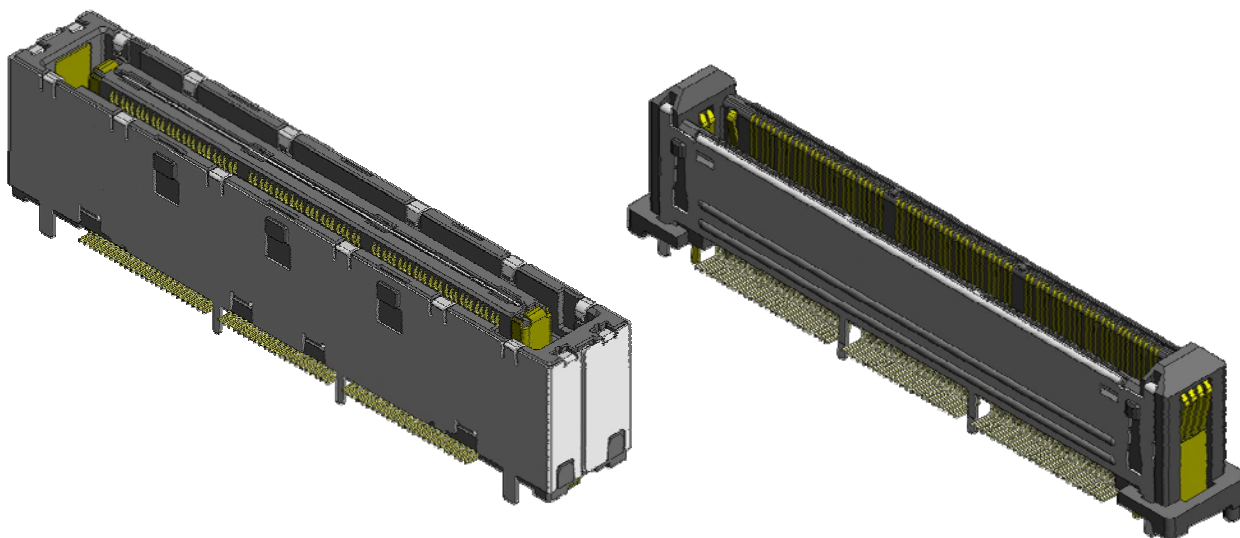
## WD2 Series

**RoHS Compliant**

The WD2 Series are docking connectors compatible with high-speed differential transmission such as PCI Express.

### Features

- Designed for high-speed serial transmission such as PCI Express and Display Port
- Ground bar on receptacle side for ESD (Electrostatic Discharge) countermeasure
- Available in several mating heights and angle variations
- Mating guide length in pitch direction  $\pm 1.3\text{mm}$ , cross direction  $\pm 1.2\text{mm}$
- 4 pos. (2 pair) for power in mating guide area with current capacity of 10A per pair, 20A in total

### General Specifications

- No. of Contacts: 100, 144 pos. (for signal) + 4 pos. (for power)
- Contact Resistance: 190m ohm max.
- Dielectric Withstanding Voltage: AC500Vr.m.s. per minute
- Rated Current: 0.5 per terminal (signal), 10 A per pair (power)
- Insulation Resistance: 100M ohm min.
- Durability: 10,000 times
- Operating Temperature: -40 deg. C to 85 deg. C

Materials and Finishes

Component	Material / Finish
Receptacle	
Signal Contact	Copper alloy / contact area: 0.3um min. Au plating over Ni
Power Contact	Copper alloy / contact area: 0.3um min. Au plating over Ni
Insulator	Glass filled LCP
Inner Insulator	Glass filled LCP
Shell	Copper alloy / Ni plating
Plate	Copper alloy / Sn plating
Plug	
Signal Contact	Copper alloy / contact area: 0.3um min. Au plating over Ni
Power Contact	Copper alloy / contact area: 0.3um min. Au plating over Ni
Insulator	Glass filled LCP
Shell	Copper alloy / Ni plating
Hold Pin	Copper alloy / Sn plating
Vacuum Area	Glass filled PPS (removed after mounting)

Ordering Information

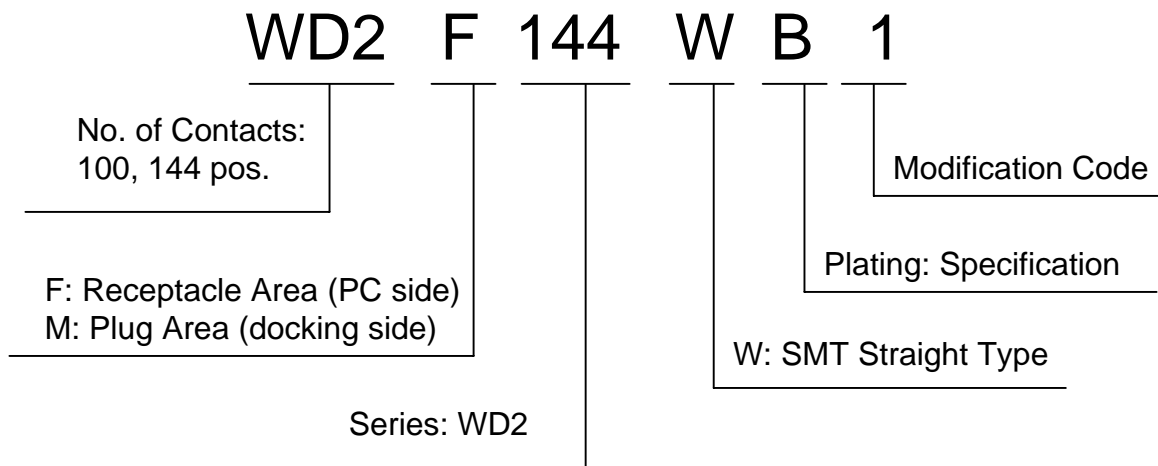

# WD2F144WB1

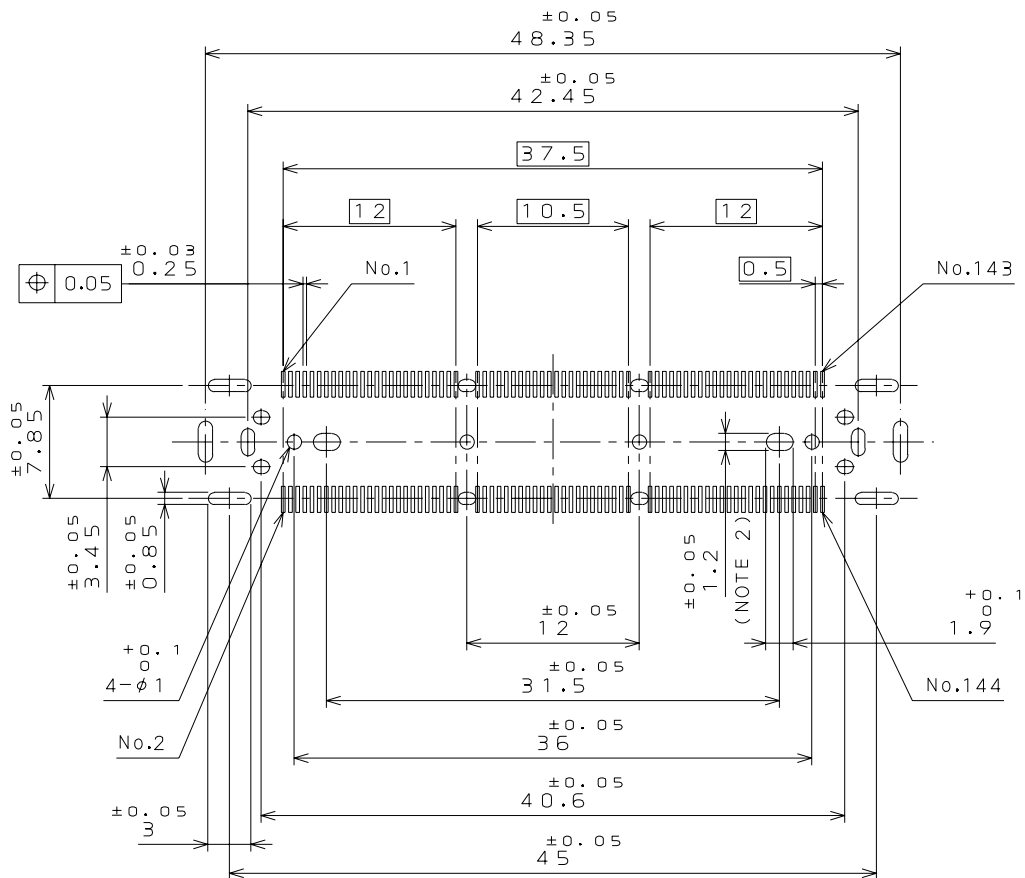
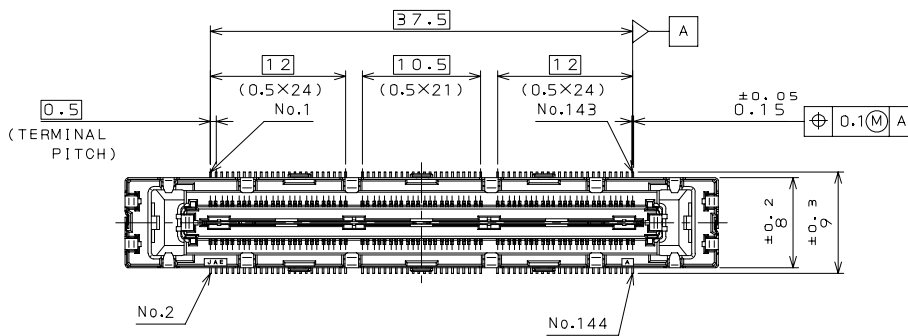
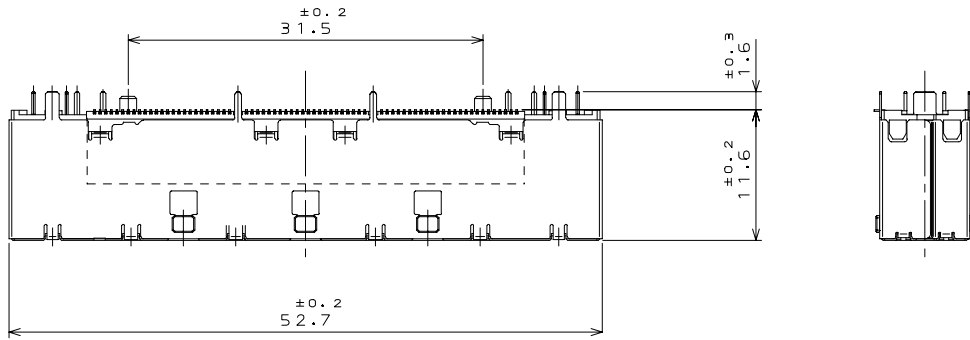

APPLICABLE P.C.B. DIMENSION (REF.)

適合基板寸法 (参考)

# WD2M144WB1

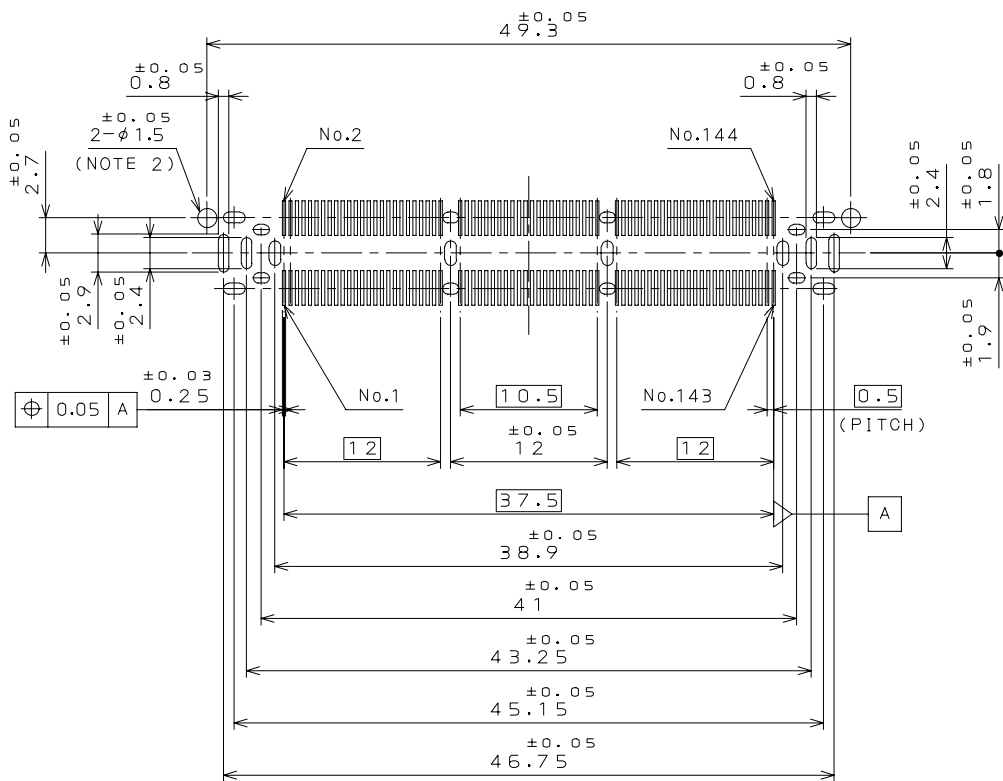
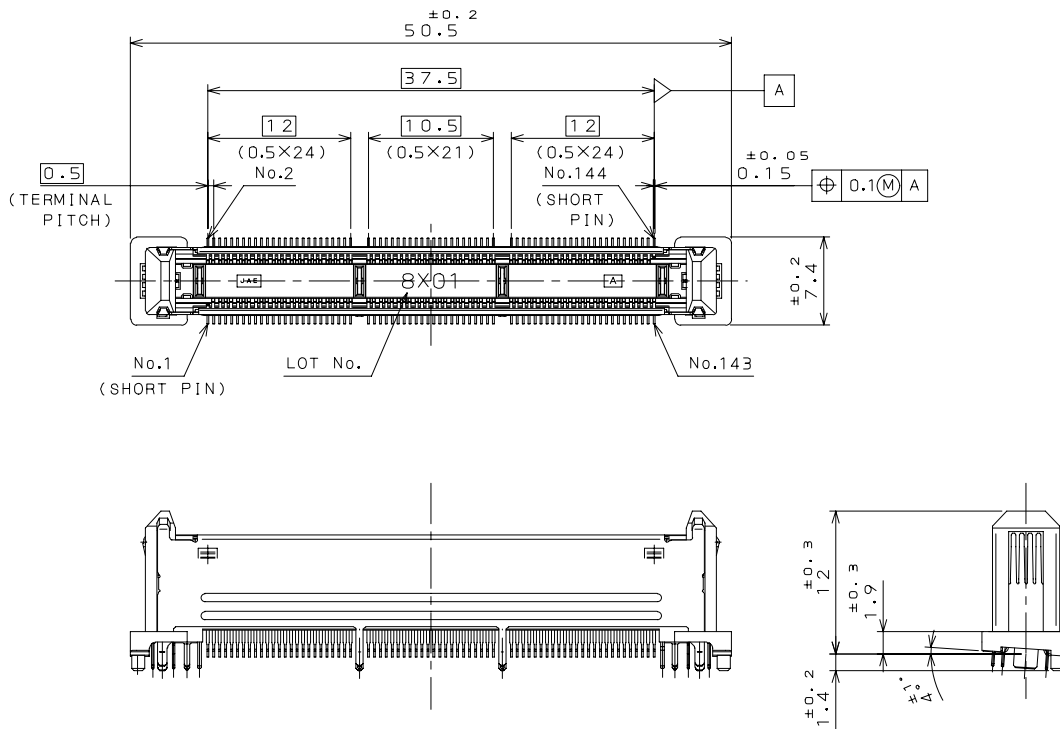

APPLICABLE P.C.B. DIMENSION (REF.)  
 適合基板寸法 (参考)

## Drawing

	Part Number	SJ Drawing	Specification
144 pos.	Receptacle (PC side)		JACS-10491-01
	WD2F144WB1	SJ107851	
	WD2F144WB1R300	SJ108414	
	WD2F144WB2	SJ108380	
	WD2F144WB2R250	SJ108381	
	WD2F144WB3	SJ108382	
	WD2F144WB3R300	SJ108383	
	WD2F144WB4	SJ108384	
	WD2F144WB4R400	SJ108385	
	WD2F144WB5	SJ108376	
	WD2F144WB5R400	SJ108416	
	Plug (docking side)		
	WD2M144WB1	SJ107852	
	WD2M144WB1R300	SJ108415	
WD2M144WB2	SJ108374		
WD2M144WB2R300	SJ108375		
100 pos.	Receptacle (PC side)		JACS-10491-02
	WD2F100WB3A	SJ108477	
	WD2F100WB3AR300	SJ108478	
	WD2F100WB5A	SJ108475	
	WD2F100WB5AR400	SJ108476	
	Plug (docking side)		
	WD2M100WB1A	SJ108473	
WD2M100WB1AR300	SJ108474		

Mating Combinations

144 pos. Variations		Receptacle (PC side)					
		Part Number	WD2F144WB1	WD2F144WB2	WD2F144WB3	WD2F144WB4	WD2F144WB5
		Drawing No.	SJ107851	SJ108380	SJ108382	SJ108384	SJ108376
		Connector Height	11.6	13.9	10.4	7.7	6.95
Plug side (docking side)	Part Number	WD2M144WB1	17.9	20.2	16.7	14	13.25
	Drawing No.	SJ107852					
	Connector Height	12					
	Mating angle	4					
	Part Number	WD2M144WB2	16.4	18.7	15.2	12.5	11.75
	Drawing No.	SJ108374					
	Connector Height	10.5					
	Mating angle	0					

100 pos. Variations		Receptacle		
		Part Number	WD2F100WB3A	WD2F100WB5A
		Drawing No.	SJ108477	SJ108475
		Connector Height	10.4	6.95
Plug	Part Number	WD2M100WB1A	16.7	13.25
	Drawing No.	SJ108473		
	Connector Height	12		
	Mating angle	4		

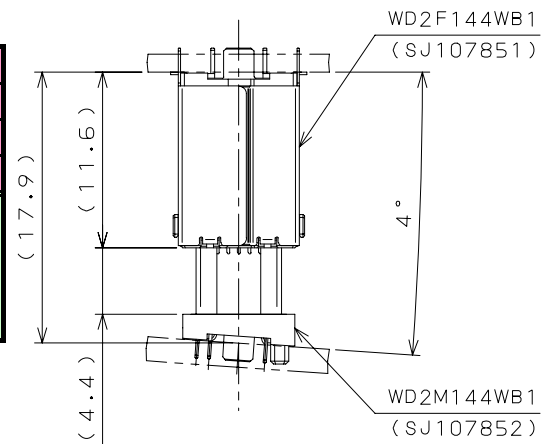

MATED CONDITION (REF.)  
 嵌合状態図 (参考)

**Japan Aviation Electronics Industry, Limited**

Product Marketing Division  
 Aobadai Building, 3-1-19, Aobadai, Meguro-ku, Tokyo 153-8539  
 Phone: +81-3-3780-2787 FAX: +81-3-3780-2946

**Notice:** Products shown in this leaflet are made for the applications listed below. However, if the above-mentioned products are to be used in aerospace devices, marine cable-connection devices, atomic power control systems, medical equipment for life-support systems, or any other specific application requiring extremely high reliability, please contact JAE for further information.  
 Recommended applications: computers, office machines, measuring devices, telecommunication devices (terminals, mobile devices), AV devices, household applications, FA devices, etc.

\* The specifications in this brochure are subject to change without notice. Please contact JAE for information.  
 JAE PMK Div. Proprietary. Copyright © 2009. Japan Aviation Electronics Industr. Ltd.



Компания «ЭлектроПласт» предлагает заключение долгосрочных отношений при поставках импортных электронных компонентов на взаимовыгодных условиях!

Наши преимущества:

- Оперативные поставки широкого спектра электронных компонентов отечественного и импортного производства напрямую от производителей и с крупнейших мировых складов;
- Поставка более 17-ти миллионов наименований электронных компонентов;
- Поставка сложных, дефицитных, либо снятых с производства позиций;
- Оперативные сроки поставки под заказ (от 5 рабочих дней);
- Экспресс доставка в любую точку России;
- Техническая поддержка проекта, помощь в подборе аналогов, поставка прототипов;
- Система менеджмента качества сертифицирована по Международному стандарту ISO 9001;
- Лицензия ФСБ на осуществление работ с использованием сведений, составляющих государственную тайну;
- Поставка специализированных компонентов (Xilinx, Altera, Analog Devices, Intersil, Interpoint, Microsemi, Aeroflex, Peregrine, Syfer, Eurofarad, Texas Instrument, Miteq, Cobham, E2V, MA-COM, Hittite, Mini-Circuits, General Dynamics и др.);

Помимо этого, одним из направлений компании «ЭлектроПласт» является направление «Источники питания». Мы предлагаем Вам помощь Конструкторского отдела:

- Подбор оптимального решения, техническое обоснование при выборе компонента;
- Подбор аналогов;
- Консультации по применению компонента;
- Поставка образцов и прототипов;
- Техническая поддержка проекта;
- Защита от снятия компонента с производства.



#### Как с нами связаться

**Телефон:** 8 (812) 309 58 32 (многоканальный)

**Факс:** 8 (812) 320-02-42

**Электронная почта:** [org@eplast1.ru](mailto:org@eplast1.ru)

**Адрес:** 198099, г. Санкт-Петербург, ул. Калинина, дом 2, корпус 4, литера А.