



LOW-VOLTAGE 10-BIT BUS SWITCH

IDT74CBTLV3384

FEATURES:

- 5Ω A/B bi-directional bus switch
- Isolation under power-off conditions
- Over-voltage tolerant
- Latch-up performance exceeds 100mA
- $V_{CC} = 2.3V - 3.6V$, Normal Range
- ESD > 2000V per MIL-STD-883, Method 3015;
> 200V using machine model (C = 200pF, R = 0)
- Available in QSOP and TSSOP packages

APPLICATIONS:

- 3.3V High Speed Bus Switching and Bus Isolation

DESCRIPTION:

The CBTLV3384 is a ten bit high-speed bus switch with low on-state resistance of the switch allowing connections to be made with minimal propagation delay.

The device is organized as dual 5-bit bus switches with separate output-enable (\overline{OE}) inputs, to allow use as two 5-bit bus switches or one 10-bit bus switch. When \overline{OE} is low, the associated 5-bit bus switch is on and A port is connected to B port. When \overline{OE} is high, the switch is open, and a high-impedance state exists between the two ports.

To ensure the high-impedance state during power up or power down, \overline{OE} should be tied to V_{CC} through a pullup resistor; the minimum value of the resistor is determined by the current-sinking capability of the driver.

FUNCTIONAL BLOCK DIAGRAM

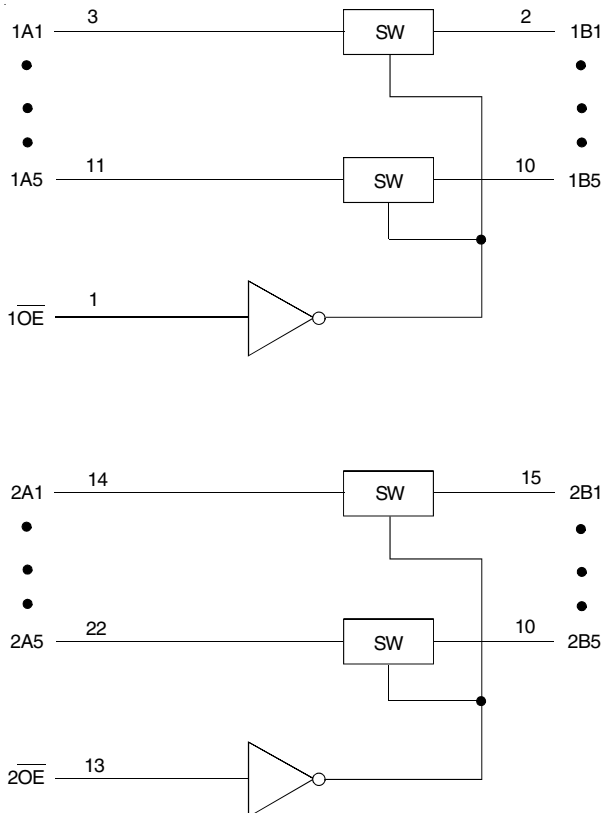

SIMPLIFIED SCHEMATIC, EACH SWITCH

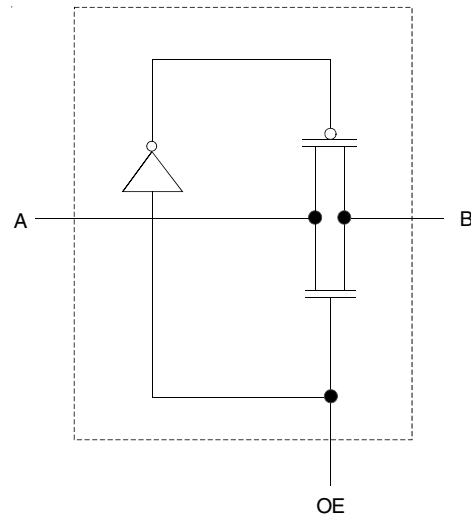

PIN CONFIGURATION

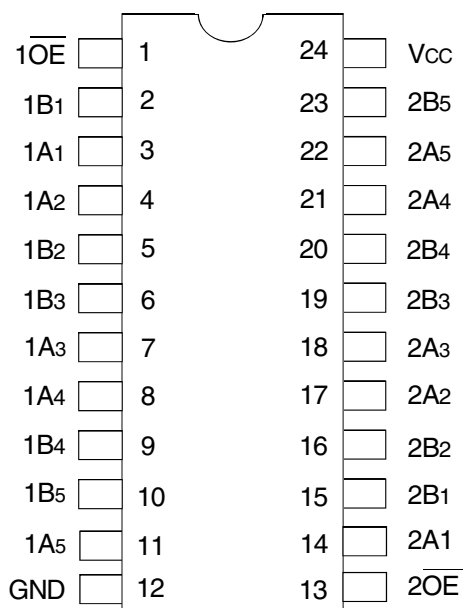

QSOP/TSSOP
TOP VIEW

ABSOLUTE MAXIMUM RATINGS⁽¹⁾

| Symbol | Description | Max | Unit |
|------------------|---|--------------|------|
| V _{CC} | Supply Voltage Range | -0.5 to +4.6 | V |
| V _I | Input Voltage Range | -0.5 to +4.6 | V |
| | Continuous Channel Current | 128 | mA |
| I _{IK} | Input Clamp Current, V _{I/O} < 0 | -50 | mA |
| T _{STG} | Storage Temperature | -65 to +150 | °C |

NOTE:

- Stresses greater than those listed under ABSOLUTE MAXIMUM RATINGS may cause permanent damage to the device. This is a stress rating only and functional operation of the device at these or any other conditions above those indicated in the operational sections of this specification is not implied. Exposure to absolute maximum rating conditions for extended periods may affect reliability.

FUNCTION TABLE⁽¹⁾

| Input | | Inputs/Outputs | |
|------------------|------------------|----------------|-----------|
| $\overline{1OE}$ | $\overline{2OE}$ | 1B1 - 1B5 | 2B1 - 2B5 |
| L | L | 1A1 - 1A5 | 2A1 - 2A5 |
| L | H | 1A1 - 1A5 | Z |
| H | L | Z | 2A1 - 2A5 |
| H | H | Z | Z |

NOTE:

- H = HIGH Voltage Level
L = LOW Voltage Level
Z = High Impedance

OPERATING CHARACTERISTICS, T_A = 25°C⁽¹⁾

| Symbol | Parameter | Test Conditions | Min. | Max. | Unit |
|-----------------|----------------------------------|--------------------------------|------|------|------|
| V _{CC} | Supply Voltage | | 2.3 | 3.6 | V |
| V _{IH} | High-Level Control Input Voltage | V _{CC} = 2.3V to 2.7V | 1.7 | — | V |
| | | V _{CC} = 2.7V to 3.6V | 2 | — | |
| V _{IL} | Low-Level Control Input Voltage | V _{CC} = 2.3V to 2.7V | — | 0.7 | V |
| | | V _{CC} = 2.7V to 3.6V | — | 0.8 | |
| T _A | Operating Free-Air Temperature | | -40 | 85 | °C |

NOTE:

- All unused control inputs of the device must be held at V_{CC} or GND to ensure proper device operation.

DC ELECTRICAL CHARACTERISTICS OVER OPERATING RANGE

Following Conditions Apply Unless Otherwise Specified:

Operating Conditions: $T_A = -40^{\circ}\text{C}$ to $+85^{\circ}\text{C}$

| Symbol | Parameter | Test Conditions | Min. | Typ. | Max. | Unit | |
|-----------------------|--|---|---------------------|------|---------|---------------|----------|
| V_{IK} | Control Inputs, Data I/O | $V_{CC} = 3V$, $I_I = -18\text{mA}$ | — | — | -1.2 | V | |
| I_I | Control Inputs, Data I/O | $V_{CC} = 3.6V$, $V_I = V_{CC}$ or GND | — | — | ± 1 | μA | |
| I_{OZ} | Data I/O | $V_{CC} = 3.6V$, $V_O = 0$ or $3.6V$, switch disabled | — | — | 5 | μA | |
| I_{OFF} | | $V_{CC} = 0$, V_I or $V_O = 0$ to $3.6V$ | — | — | 50 | μA | |
| I_{CC} | | $V_{CC} = 3.6V$, $I_O = 0$, $V_I = V_{CC}$ or GND | — | — | 10 | μA | |
| $\Delta I_{CC}^{(1)}$ | Control Inputs | $V_{CC} = 3.6V$, one input at $3V$, other inputs at V_{CC} or GND | — | — | 300 | μA | |
| C_I | Control Inputs | $V_I = 3V$ or 0 | — | 4 | — | pF | |
| $C_{IO(OFF)}$ | | $V_O = 3V$ or 0 , $\overline{OE} = V_{CC}$ | — | 7 | — | pF | |
| $R_{ON}^{(2)}$ | Max. at $V_{CC} = 2.3V$ Typ. at $V_{CC} = 2.5V$ | $V_I = 0$ | $I_O = 64\text{mA}$ | — | 5 | 8 | Ω |
| | | | $I_O = 24\text{mA}$ | — | 5 | 8 | |
| | $V_I = 1.7V$ | $I_O = 15\text{mA}$ | — | 27 | 40 | | |
| | $V_{CC} = 3V$ | $V_I = 0$ | $I_O = 64\text{mA}$ | — | 5 | 7 | |
| | | | $I_O = 24\text{mA}$ | — | 5 | 7 | |
| | | $V_I = 2.4V$ | $I_O = 15\text{mA}$ | — | 10 | 15 | |

NOTES:

- The increase in supply current is attributable to each current that is at the specified voltage level rather than V_{CC} or GND.
- This is measured by the voltage drop between the A and B terminals at the indicated current through the switch. On-state resistance is determined by the lower of the voltages of the two (A or B) terminals.

SWITCHING CHARACTERISTICS

| Symbol | Parameter | $V_{CC} = 2.5V \pm 0.2V$ | | $V_{CC} = 3.3V \pm 0.3V$ | | Unit |
|----------------|--|--------------------------|------|--------------------------|------|------|
| | | Min. | Max. | Min. | Max. | |
| $t_{PD}^{(1)}$ | Propagation Delay A to B or B to A | — | 0.15 | — | 0.25 | ns |
| t_{EN} | Output Enable Time \overline{OE} to A or B | 1 | 5 | 1 | 4.3 | ns |
| t_{DIS} | Output Disable Time \overline{OE} to A or B | 1 | 5.5 | 1 | 5.5 | ns |

- NOTE:**
- The propagation delay is the calculated RC time constant of the typical on-state resistance of the switch and the specified load capacitance driven by an ideal voltage source (zero output impedance).

TEST CIRCUITS AND WAVEFORMS

TEST CONDITIONS

| Symbol | $V_{CC}^{(1)} = 3.3V \pm 0.3V$ | $V_{CC}^{(2)} = 2.5V \pm 0.2V$ | Unit |
|------------|--------------------------------|--------------------------------|------|
| V_{LOAD} | 6 | $2 \times V_{CC}$ | V |
| V_{IH} | 3 | V_{CC} | V |
| V_T | 1.5 | $V_{CC} / 2$ | V |
| V_{LZ} | 300 | 150 | mV |
| V_{HZ} | 300 | 150 | mV |
| C_L | 50 | 30 | pF |

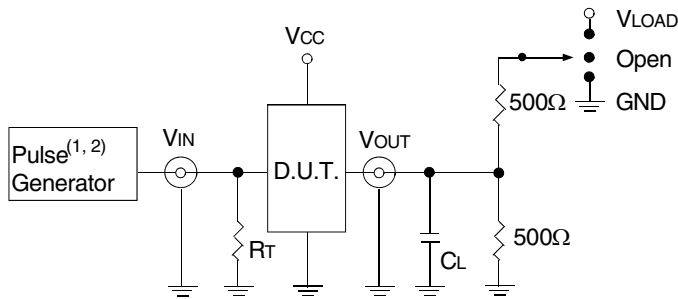

Test Circuits for All Outputs

DEFINITIONS:

C_L = Load capacitance: includes jig and probe capacitance.
 R_T = Termination resistance: should be equal to Z_{OUT} of the Pulse Generator.

NOTES:

1. Pulse Generator for All Pulses: Rate $\leq 10\text{MHz}$; $t_r \leq 2.5\text{ns}$; $t_f \leq 2.5\text{ns}$.
2. Pulse Generator for All Pulses: Rate $\leq 10\text{MHz}$; $t_r \leq 2\text{ns}$; $t_f \leq 2.5\text{ns}$.

SWITCH POSITION

| Test | Switch |
|-------------------|------------|
| t_{PLZ}/t_{PZL} | V_{LOAD} |
| t_{PHZ}/t_{PZH} | GND |
| t_{PD} | Open |

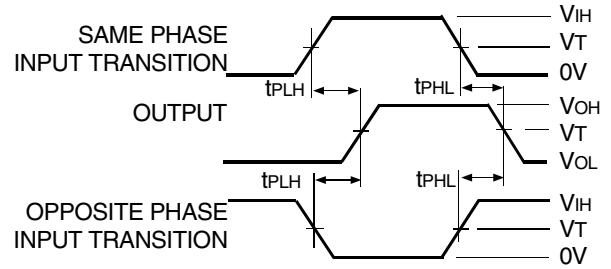

Propagation Delay

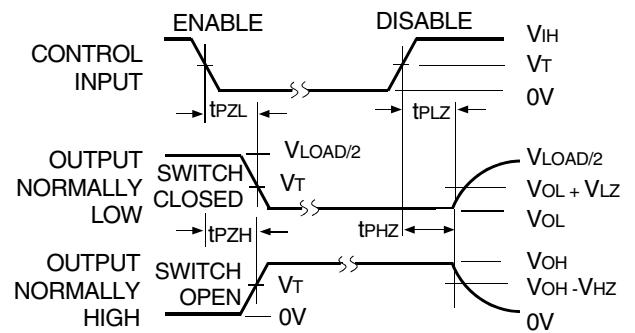

Enable and Disable Times

ORDERING INFORMATION

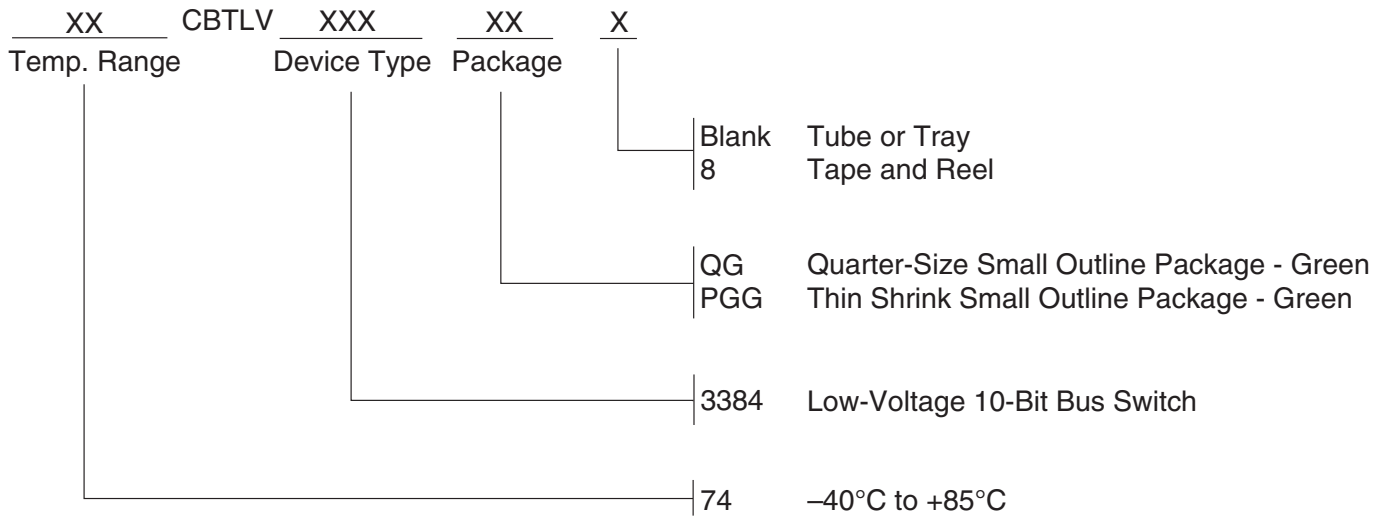

Datasheet Document History

12/18/2014 Pg. 5 Updated the ordering information by removing non RoHS part and by adding Tape and Reel information.



CORPORATE HEADQUARTERS
6024 Silver Creek Valley Road
San Jose, CA 95138

for SALES:
800-345-7015 or 408-284-8200
fax: 408-284-2775
www.idt.com

for Tech Support:
logichelp@idt.com



Компания «ЭлектроПласт» предлагает заключение долгосрочных отношений при поставках импортных электронных компонентов на взаимовыгодных условиях!

Наши преимущества:

- Оперативные поставки широкого спектра электронных компонентов отечественного и импортного производства напрямую от производителей и с крупнейших мировых складов;
- Поставка более 17-ти миллионов наименований электронных компонентов;
- Поставка сложных, дефицитных, либо снятых с производства позиций;
- Оперативные сроки поставки под заказ (от 5 рабочих дней);
- Экспресс доставка в любую точку России;
- Техническая поддержка проекта, помощь в подборе аналогов, поставка прототипов;
- Система менеджмента качества сертифицирована по Международному стандарту ISO 9001;
- Лицензия ФСБ на осуществление работ с использованием сведений, составляющих государственную тайну;
- Поставка специализированных компонентов (Xilinx, Altera, Analog Devices, Intersil, Interpoint, Microsemi, Aeroflex, Peregrine, Syfer, Eurofarad, Texas Instrument, Miteq, Cobham, E2V, MA-COM, Hittite, Mini-Circuits, General Dynamics и др.);

Помимо этого, одним из направлений компании «ЭлектроПласт» является направление «Источники питания». Мы предлагаем Вам помощь Конструкторского отдела:

- Подбор оптимального решения, техническое обоснование при выборе компонента;
- Подбор аналогов;
- Консультации по применению компонента;
- Поставка образцов и прототипов;
- Техническая поддержка проекта;
- Защита от снятия компонента с производства.



Как с нами связаться

Телефон: 8 (812) 309 58 32 (многоканальный)

Факс: 8 (812) 320-02-42

Электронная почта: org@eplast1.ru

Адрес: 198099, г. Санкт-Петербург, ул. Калинина, дом 2, корпус 4, литера А.