

# NCP1379

## Quasi-Resonant Current-Mode Controller for High-Power Universal Off-line Supplies

The NCP1379 hosts a high-performance circuitry aimed to powering quasi-resonant converters. Capitalizing on a proprietary valley-lockout system, the controller shifts gears and reduces the switching frequency as the power loading becomes lighter. This results in a stable operation despite switching events always occurring in the drain-source valley. This system works down to the 4<sup>th</sup> valley and toggles to a variable frequency mode beyond, ensuring an excellent standby power performance.

The controller includes an Over Power Protection circuit which clamps the delivered power at high-line. Safety-wise, a fixed internal timer relies on the feedback voltage to detect a fault. Once the timer elapses, the controller stops and enters auto-recovery mode, ensuring a low duty-cycle burst operation. To further improve the safety of the power supply, the NCP1379 features a pin to implement a combined brown-out/overvoltage protection.

Particularly well suited for TVs power supply applications, the controller features a low startup voltage allowing the use of an auxiliary power supply to power the device.

### Features

- Quasi-Resonant Peak Current-Mode Control Operation
- Valley Switching Operation with Valley-Lockout for Noise-Immune Operation
- Frequency Foldback at Light Load to Improve the Light Load Efficiency
- Adjustable Over Power Protection
- Auto-Recovery Output Short-Circuit Protection
- Fixed Internal 80 ms Timer for Short-Circuit Protection
- Combined Overvoltage Protection and Brown-out
- +500 mA / -800 mA Peak Current Source/Sink Capability
- Internal Temperature Shutdown
- Direct Optocoupler Connection
- Low  $V_{CC(on)}$  Allowing to Use a Standby Power Supply to Power the Device
- Extremely Low No-Load Standby Power
- SO8 Package
- These Devices are Pb-Free and are RoHS Compliant

### Typical Applications

- High Power ac-dc Converters for TVs, Set-Top Boxes etc.
- Offline Adapters for Notebooks



ON Semiconductor®

<http://onsemi.com>

## QUASI-RESONANT PWM CONTROLLER FOR HIGH POWER AC-DC WALL AD- APTERS

### MARKING DIAGRAMS



SOIC-8  
D SUFFIX  
CASE 751

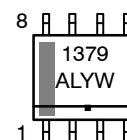

1379 = Specific Device Code  
A = Assembly Location  
L = Wafer Lot  
Y = Year  
W = Work Week  
▪ = Pb-Free Package

### PIN CONNECTIONS

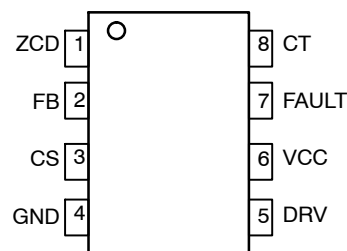

### ORDERING INFORMATION

See detailed ordering and shipping information in the package dimensions section on page 21 of this data sheet.

# NCP1379

## TYPICAL APPLICATION EXAMPLE

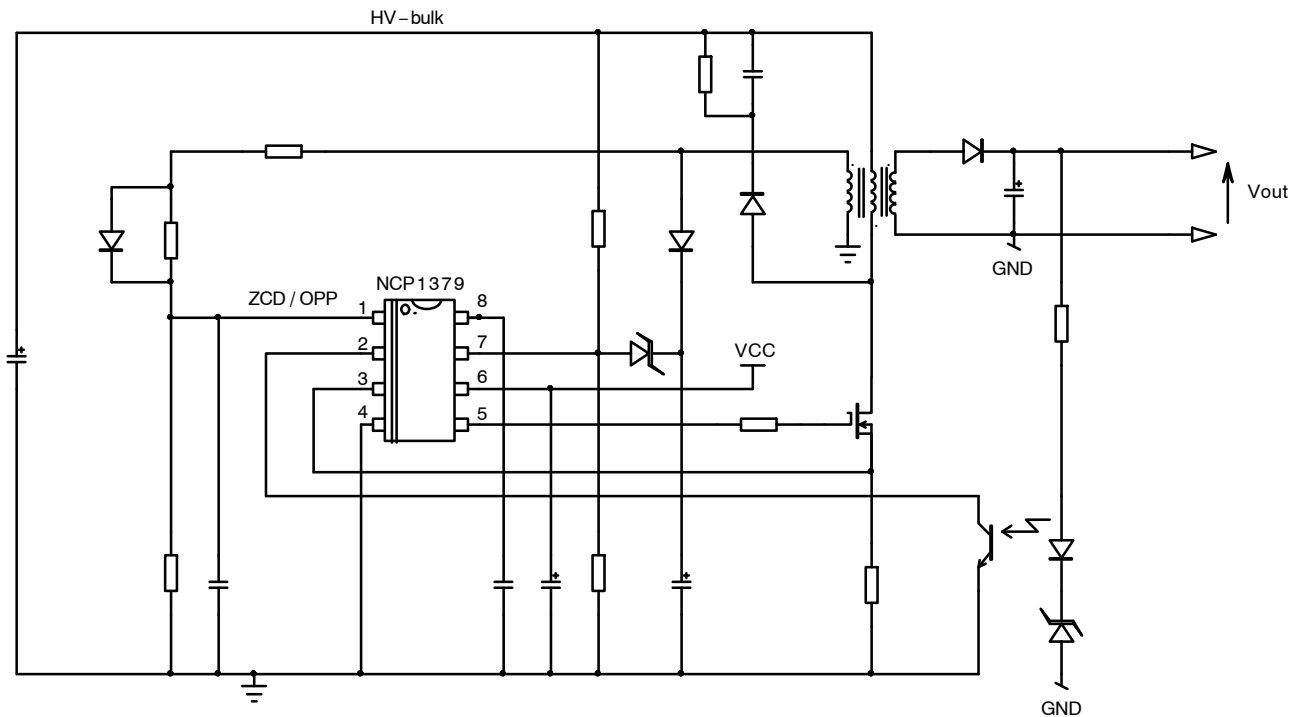

Figure 1. Typical Application Schematic

### PIN FUNCTION DESCRIPTION

Pin N°	Pin Name	Function	Pin Description
1	ZCD	Zero Crossing Detection Adjust the over power protection	Connected to the auxiliary winding, this pin detects the core reset event. Also, injecting a negative voltage smaller than 0.3 V on this pin will perform over power protection.
2	FB	Feedback pin	Hooking an optocoupler collector to this pin will allow regulation.
3	CS	Current sense	This pin monitors the primary peak.
4	GND	-	The controller ground
5	DRV	Driver output	The driver's output to an external MOSFET
6	V <sub>CC</sub>	Supplies the controller	This pin is connected to an external auxiliary voltage.
7	Fault	Overvoltage protection Brown-out	This pin observes the HV rail and protects the circuit in case of low main conditions. It also offers a way to latch the circuit in case of over voltage event.
8	C <sub>T</sub>	Timing capacitor	A capacitor connected to this pin acts as the timing capacitor in fold-back mode.

INTERNAL CIRCUIT ARCHITECTURE

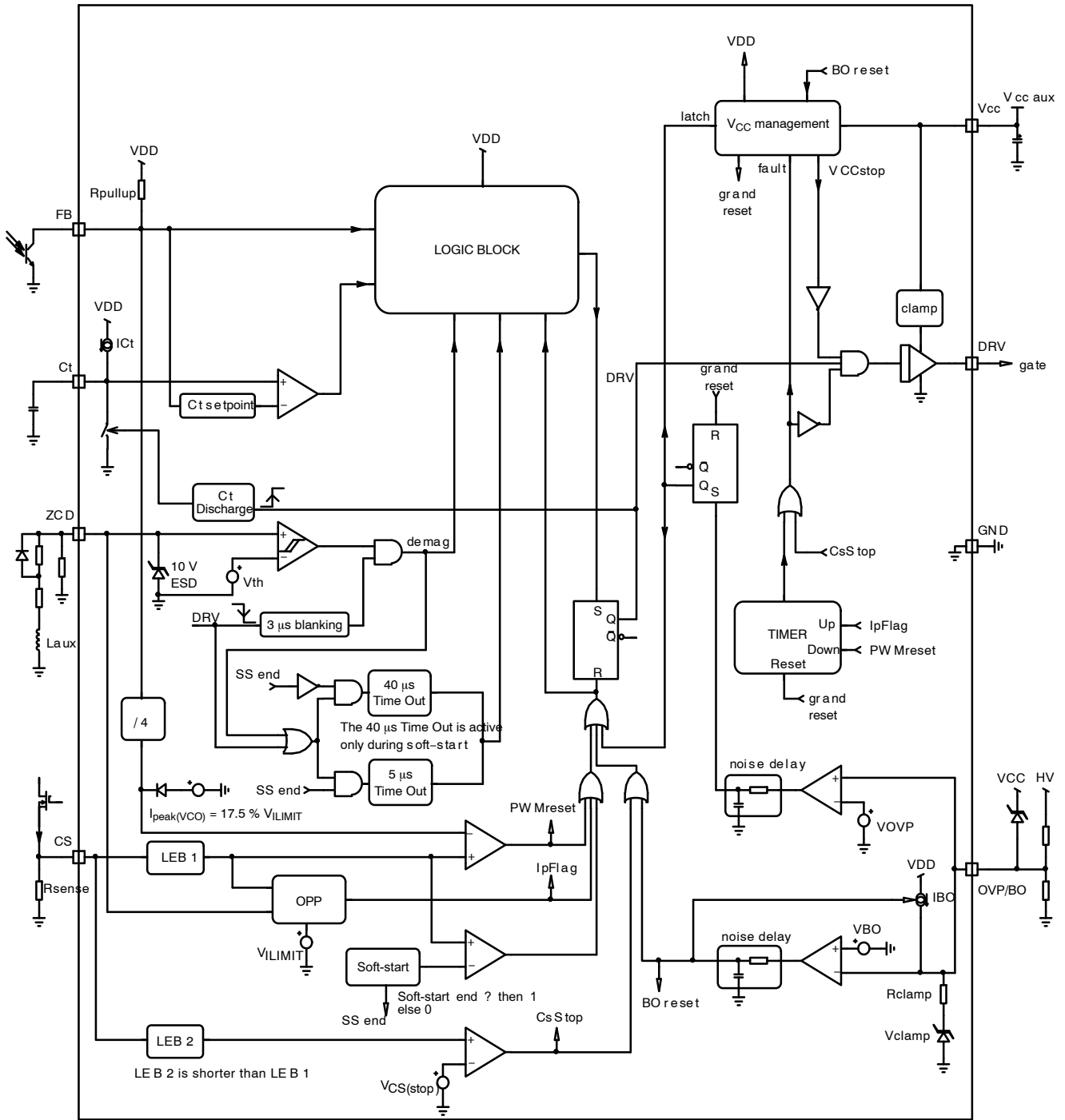

Figure 2. Internal Circuit Architecture

# NCP1379

## MAXIMUM RATINGS TABLE(S)

Symbol	Rating	Value	Unit
V <sub>CC(MAX)</sub> I <sub>CC(MAX)</sub>	Maximum Power Supply voltage, VCC pin, continuous voltage Maximum current for VCC pin	-0.3 to 28 ±30	V mA
V <sub>DRV(MAX)</sub> I <sub>DRV(MAX)</sub>	Maximum driver pin voltage, DRV pin, continuous voltage Maximum current for DRV pin	-0.3 to 20 ±1000	V mA
V <sub>MAX</sub> I <sub>MAX</sub>	Maximum voltage on low power pins (except pins DRV and V <sub>CC</sub> ) Current range for low power pins (except pins ZCD, DRV and V <sub>CC</sub> )	-0.3 to 10 ±10	V mA
I <sub>ZCD(MAX)</sub>	Maximum current for ZCD pin	+3 / -2	mA
R <sub>θJA</sub>	Thermal Resistance Junction-to-Air	120	°C/W
T <sub>J(MAX)</sub>	Maximum Junction Temperature	150	°C
	Operating Temperature Range	-40 to +125	°C
	Storage Temperature Range	-60 to +150	°C
	ESD Capability, Human Body Model (HBM) model (Note 1)	4	kV
	ESD Capability, CDM model (Note 1)	2	kV

Stresses exceeding Maximum Ratings may damage the device. Maximum Ratings are stress ratings only. Functional operation above the Recommended Operating Conditions is not implied. Extended exposure to stresses above the Recommended Operating Conditions may affect device reliability.

- This device series contains ESD protection and exceeds the following tests: Human Body Model 4000 V per JEDEC Standard JESD22, Method A114E. Charged Device Model 2000 V per JEDEC Standard JESD22-C101D
- This device contains latchup protection and exceeds 100 mA per JEDEC Standard JESD78.

**ELECTRICAL CHARACTERISTICS** (Unless otherwise noted: For typical values T<sub>J</sub> = 25°C, V<sub>CC</sub> = 12 V, V<sub>ZCD</sub> = 0 V, V<sub>FB</sub> = 3 V, V<sub>CS</sub> = 0 V, V<sub>fault</sub> = 1.5 V, C<sub>T</sub> = 680 pF) For min/max values T<sub>J</sub> = -40°C to +125°C, Max T<sub>J</sub> = 150°C, V<sub>CC</sub> = 12 V)

Symbol	Parameter	Conditions	Min	Typ	Max	Unit
--------	-----------	------------	-----	-----	-----	------

### SUPPLY SECTION – STARTUP AND SUPPLY CIRCUITS

V <sub>CC(on)</sub> V <sub>CC(off)</sub> V <sub>CC(hyst)</sub> V <sub>CC(reset)</sub>	Supply Voltage Startup Threshold Minimum Operating Voltage Hysteresis V <sub>CC(on)</sub> – V <sub>CC(off)</sub> Internal logic reset	V <sub>CC</sub> increasing V <sub>CC</sub> decreasing V <sub>CC</sub> decreasing	10.5 8.3 2.0 6	11.4 9.0 2.4 7	12.3 9.4 – 8	V
t <sub>VCC(off)</sub>	V <sub>CC(off)</sub> noise filter		–	5	–	μs
t <sub>VCC(reset)</sub>	V <sub>CC(reset)</sub> noise filter		–	20	–	μs
I <sub>CC(start)</sub>	Startup current	FB pin open V <sub>CC</sub> = V <sub>CC(on)</sub> – 0.5 V	–	0.7	1.2	mA
I <sub>CC1</sub> I <sub>CC2</sub> I <sub>CC3A</sub> I <sub>CC3B</sub>	Supply Current Device Disabled/Fault (Note 3) Device Enabled/No output load on pin 5 Device Switching (F <sub>sw</sub> = 65 kHz) Device Switching (F <sub>sw</sub> around 12 kHz)	V <sub>CC</sub> > V <sub>CC(off)</sub> F <sub>sw</sub> = 10 kHz C <sub>DRV</sub> = 1 nF, F <sub>sw</sub> = 65 kHz C <sub>DRV</sub> = 1 nF, V <sub>FB</sub> = 1.25 V	– – – –	1.7 1.7 2.65 2.0	2.0 2.0 3.00 –	mA

### CURRENT COMPARATOR – CURRENT SENSE

V <sub>LIM</sub>	Current Sense Voltage Threshold	V <sub>FB</sub> = 4 V, V <sub>CS</sub> increasing	0.76	0.80	0.84	V
t <sub>LEB</sub>	Leading Edge Blanking Duration for V <sub>LIM</sub>	Minimum on time minus t <sub>LIM</sub>	210	275	330	ns
I <sub>bias</sub>	Input Bias Current (Note 3)	DRV high	-2	–	2	μA
t <sub>LIM</sub>	Propagation Delay	V <sub>CS</sub> > V <sub>LIM</sub> to DRV turn-off	–	125	175	ns
I <sub>peak(VCO)</sub>	Percentage of maximum peak current level at which VCO takes over (Note 4)	V <sub>FB</sub> = 0.4 V, V <sub>CS</sub> increasing	15.4	17.5	19.6	%

- Guaranteed by design
- The peak current setpoint goes down as the load decreases. It is frozen below I<sub>peak(VCO)</sub> (I<sub>peak</sub> = cst)
- If negative voltage in excess to -300 mV is applied to ZCD pin, the current setpoint decrease is no longer guaranteed to be linear
- Minimum value for T<sub>J</sub> = 125°C

# NCP1379

**ELECTRICAL CHARACTERISTICS** (Unless otherwise noted: For typical values  $T_J = 25^\circ\text{C}$ ,  $V_{CC} = 12\text{ V}$ ,  $V_{ZCD} = 0\text{ V}$ ,  $V_{FB} = 3\text{ V}$ ,  $V_{CS} = 0\text{ V}$ ,  $V_{\text{fault}} = 1.5\text{ V}$ ,  $C_T = 680\text{ pF}$ ) For min/max values  $T_J = -40^\circ\text{C}$  to  $+125^\circ\text{C}$ , Max  $T_J = 150^\circ\text{C}$ ,  $V_{CC} = 12\text{ V}$ )

Symbol	Parameter	Conditions	Min	Typ	Max	Unit
--------	-----------	------------	-----	-----	-----	------

## CURRENT COMPARATOR – CURRENT SENSE

$V_{\text{OPP(MAX)}}$	Setpoint decrease for $V_{ZCD} = -300\text{ mV}$ (Note 5)	$V_{ZCD} = -300\text{ mV}$ , $V_{FB} = 4\text{ V}$ , $V_{CS}$ increasing	35.0	37.5	40.0	%
$V_{CS(\text{stop})}$	Threshold for immediate fault protection activation		1.125	1.200	1.275	V
$t_{\text{BCS}}$	Leading Edge Blanking Duration for $V_{CS(\text{stop})}$		–	120	–	ns

## DRIVE OUTPUT – GATE DRIVE

$R_{\text{SNK}}$ $R_{\text{SRC}}$	Drive Resistance DRV Sink DRV Source	$V_{\text{DRV}} = 10\text{ V}$ $V_{\text{DRV}} = 2\text{ V}$	– –	12.5 20	– –	$\Omega$
$I_{\text{SNK}}$ $I_{\text{SRC}}$	Drive current capability DRV Sink DRV Source	$V_{\text{DRV}} = 10\text{ V}$ $V_{\text{DRV}} = 2\text{ V}$	– –	800 500	– –	mA
$t_r$	Rise Time (10 % to 90 %)	$C_{\text{DRV}} = 1\text{ nF}$ , $V_{\text{DRV}}$ from 0 to 12 V	–	40	75	ns
$t_f$	Fall Time (90 % to 10 %)	$C_{\text{DRV}} = 1\text{ nF}$ , $V_{\text{DRV}}$ from 0 to 12 V	–	25	60	ns
$V_{\text{DRV(low)}}$	DRV Low Voltage	$V_{CC} = V_{CC(\text{off})} + 0.2\text{ V}$ $C_{\text{DRV}} = 1\text{ nF}$ , $R_{\text{DRV}} = 33\text{ k}\Omega$	8.4	9.1	–	V
$V_{\text{DRV(high)}}$	DRV High Voltage (Note 6)	$V_{CC} = V_{CC(\text{MAX})}$ $C_{\text{DRV}} = 1\text{ nF}$	10.5	13.0	15.5	V

## DEMAGNETIZATION INPUT – ZERO VOLTAGE DETECTION CIRCUIT

$V_{ZCD(\text{TH})}$	ZCD threshold voltage	$V_{ZCD}$ decreasing	35	55	90	mV
$V_{ZCD(\text{HYS})}$	ZCD hysteresis	$V_{ZCD}$ increasing	15	35	55	mV
$V_{\text{CH}}$ $V_{\text{CL}}$	Input clamp voltage High state Low state	$I_{\text{pin1}} = 3.0\text{ mA}$ $I_{\text{pin1}} = -2.0\text{ mA}$	8 –0.9	10 –0.7	12 –0.3	V
$t_{\text{DEM}}$	Propagation Delay	$V_{ZCD}$ decreasing from 4 V to –0.3 V	–	150	250	ns
$C_{\text{PAR}}$	Internal input capacitance		–	10	–	pF
$t_{\text{BLANK}}$	Blanking delay after on–time		2.30	3.15	4.00	$\mu\text{s}$
$t_{\text{outSS}}$ $t_{\text{out}}$	Timeout after last demag transition	During soft–start After the end of soft–start	28 5.0	41 5.9	54 6.7	$\mu\text{s}$
$R_{ZCD(\text{pdown})}$	Pulldown resistor (Note 3)		140	320	700	k $\Omega$

## TIMING CAPACITOR – TIMING CAPACITOR

$V_{\text{CT(MAX)}}$	Maximum voltage on $C_T$ pin	$V_{FB} < V_{FB(\text{TH})}$	5.15	5.40	5.65	V
$I_{\text{CT}}$	Source current	$V_{\text{CT}} = 0\text{ V}$	18	20	22	$\mu\text{A}$
$V_{\text{CT(MIN)}}$	Minimum voltage on $C_T$ pin, discharge switch activated		–	–	90	mV
$C_T$	Recommended timing capacitor value			220		pF

## FEEDBACK SECTION – FEEDBACK

$R_{\text{FB(pullup)}}$	Internal pullup resistor		15	18	22	k $\Omega$
$I_{\text{ratio}}$	Pin FB to current setpoint division ratio		3.8	4.0	4.2	
$V_{\text{FB(TH)}}$	FB pin threshold under which $C_T$ is clamped to $V_{\text{CT(MAX)}}$		0.26	0.30	0.34	V

3. Guaranteed by design
4. The peak current setpoint goes down as the load decreases. It is frozen below  $I_{\text{peak(VCO)}}$  ( $I_{\text{peak}} = \text{cst}$ )
5. If negative voltage in excess to –300 mV is applied to ZCD pin, the current setpoint decrease is no longer guaranteed to be linear
6. Minimum value for  $T_J = 125^\circ\text{C}$

# NCP1379

**ELECTRICAL CHARACTERISTICS** (Unless otherwise noted: For typical values  $T_J = 25^\circ\text{C}$ ,  $V_{CC} = 12\text{ V}$ ,  $V_{ZCD} = 0\text{ V}$ ,  $V_{FB} = 3\text{ V}$ ,  $V_{CS} = 0\text{ V}$ ,  $V_{\text{fault}} = 1.5\text{ V}$ ,  $C_T = 680\text{ pF}$ ) For min/max values  $T_J = -40^\circ\text{C}$  to  $+125^\circ\text{C}$ , Max  $T_J = 150^\circ\text{C}$ ,  $V_{CC} = 12\text{ V}$ )

Symbol	Parameter	Conditions	Min	Typ	Max	Unit
--------	-----------	------------	-----	-----	-----	------

## FEEDBACK SECTION – FEEDBACK

$V_{H2D}$	Valley threshold FB voltage where 1 <sup>st</sup> valley ends and 2 <sup>nd</sup> valley starts	$V_{FB}$ decreases	1.316	1.4	1.484	V
$V_{H3D}$	FB voltage where 2 <sup>nd</sup> valley ends and 3 <sup>rd</sup> valley starts	$V_{FB}$ decreases	1.128	1.2	1.272	
$V_{H4D}$	FB voltage where 3 <sup>rd</sup> valley ends and 4 <sup>th</sup> valley starts	$V_{FB}$ decreases	0.846	0.9	0.954	
$V_{HVCOD}$	FB voltage where 4 <sup>th</sup> valley ends and VCO starts	$V_{FB}$ decreases	0.732	0.8	0.828	
$V_{HVCOI}$	FB voltage where VCO ends and 4 <sup>th</sup> valley starts	$V_{FB}$ increases	1.316	1.4	1.484	
$V_{H4I}$	FB voltage where 4 <sup>th</sup> valley ends and 3 <sup>rd</sup> valley starts	$V_{FB}$ increases	1.504	1.6	1.696	
$V_{H3I}$	FB voltage where 3 <sup>rd</sup> valley ends and 2 <sup>nd</sup> valley starts	$V_{FB}$ increases	1.692	1.8	1.908	
$V_{H2I}$	FB voltage where 2 <sup>nd</sup> valley ends and 1 <sup>st</sup> valley starts	$V_{FB}$ increases	1.880	2.0	2.120	

## PROTECTIONS – FAULT PROTECTION

$T_{SHDN}$	Thermal Shutdown	Device switching ( $F_{SW}$ around 65 kHz)	140	–	170	$^\circ\text{C}$
$T_{SHDN(HYS)}$	Thermal Shutdown Hysteresis		–	40	–	$^\circ\text{C}$
$t_{OVL D}$	Overload Timer	$V_{FB} = 4\text{ V}$ , $V_{CS} > V_{ILIM}$	75	85	95	ms
$t_{OVL D(off)}$	OFF phase in auto-recovery fault mode		1.0	1.2	1.4	s
$t_{SSTART}$	Soft-start duration	$V_{FB} = 4\text{ V}$ , $V_{CS}$ ramping up, measured from 1 <sup>st</sup> DRV pulse to $V_{CS(peak)} = 90\%$ of $V_{ILIM}$	2.8	3.8	4.8	ms
$V_{BO}$	Brown-Out level	$V_{Fault}$ decreasing	0.744	0.800	0.856	V
$I_{BO}$	Sourced hysteresis current $V_{Fault} > V_{BO}$	$V_{Fault} = V_{BO} + 0.2\text{ V}$	9	10	11	$\mu\text{A}$
$t_{BO(delay)}$	Delay before entering and exiting Brown-out		22.5	30.0	37.5	$\mu\text{s}$
$V_{OVP}$	Internal Fault detection level for OVP	$V_{Fault}$ increasing	2.35	2.5	2.65	V
$t_{latch(delay)}$	Delay before latch confirmation (OVP)		22.5	30	37.5	$\mu\text{s}$
$V_{Fault(clamp)}$	Clamped voltage (Fault pin left open)	Fault pin open	1.0	1.2	1.4	V
$R_{Fault(clamp)}$	Clamping resistor (Note 3)		1.30	1.55	1.80	k $\Omega$

3. Guaranteed by design
4. The peak current setpoint goes down as the load decreases. It is frozen below  $I_{peak(VCO)}$  ( $I_{peak} = cst$ )
5. If negative voltage in excess to  $-300\text{ mV}$  is applied to ZCD pin, the current setpoint decrease is no longer guaranteed to be linear
6. Minimum value for  $T_J = 125^\circ\text{C}$

# NCP1379

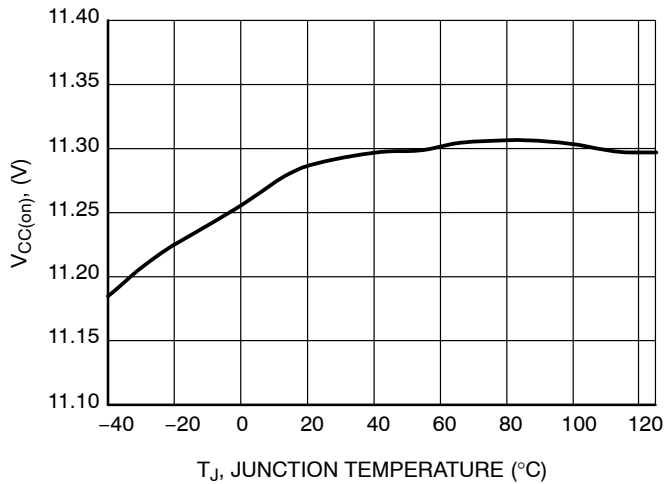

Figure 3.  $V_{CC(on)}$  vs. Junction Temperature

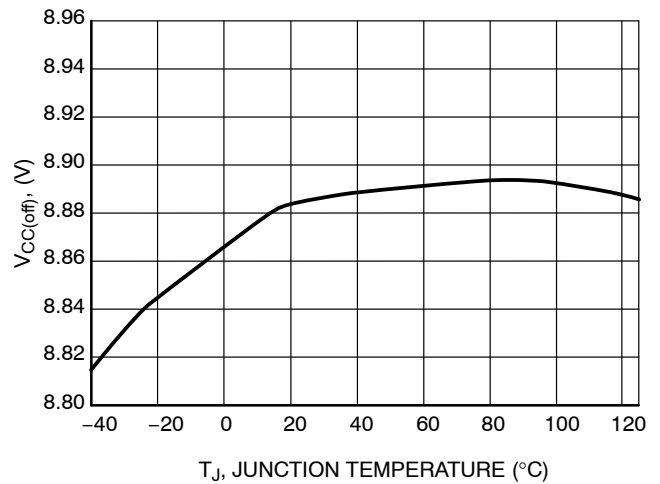

Figure 4.  $V_{CC(off)}$  vs. Junction Temperature

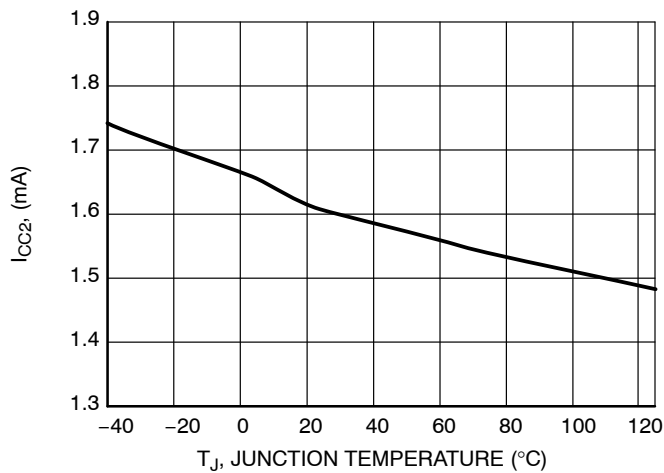

Figure 5.  $I_{CC2}$  vs. Junction Temperature

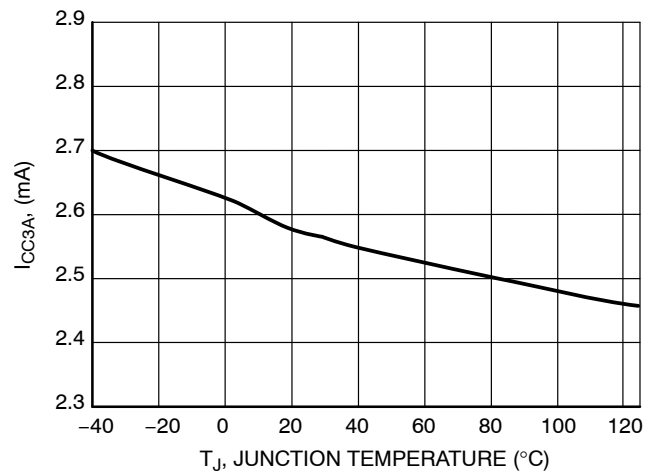

Figure 6.  $I_{CC3A}$  vs. Junction Temperature

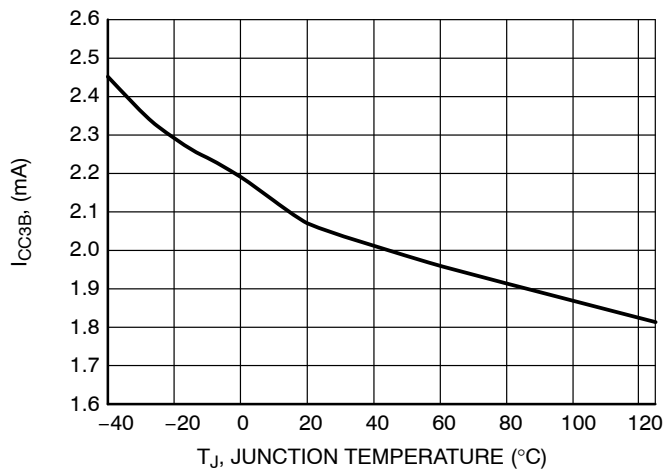

Figure 7.  $I_{CC3B}$  vs. Junction Temperature

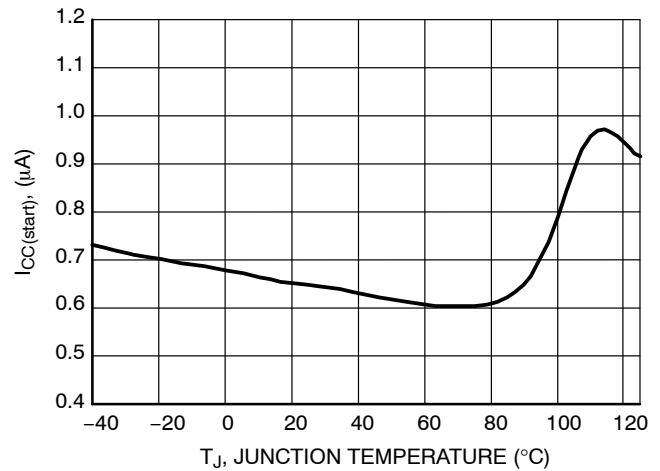

Figure 8.  $I_{CC(start)}$  vs. Junction Temperature

# NCP1379

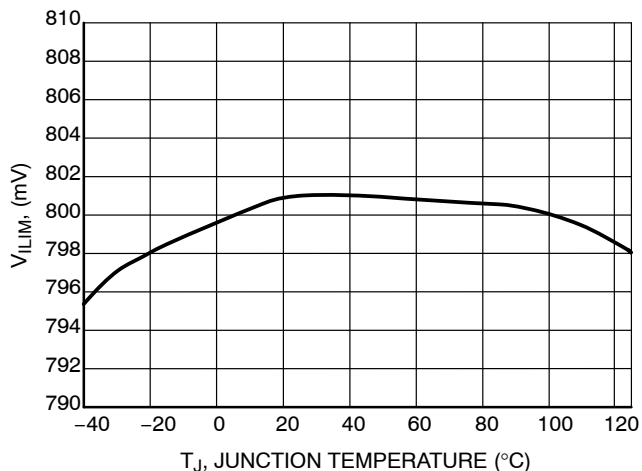

Figure 9.  $V_{ILIM}$  vs. Junction Temperature

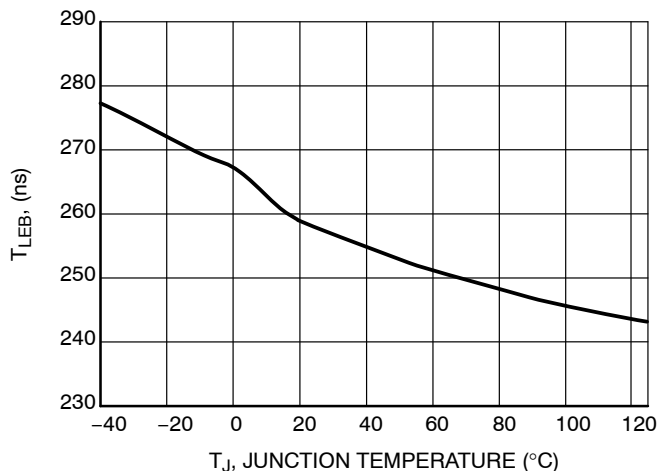

Figure 10.  $T_{LEB}$  vs. Junction Temperature

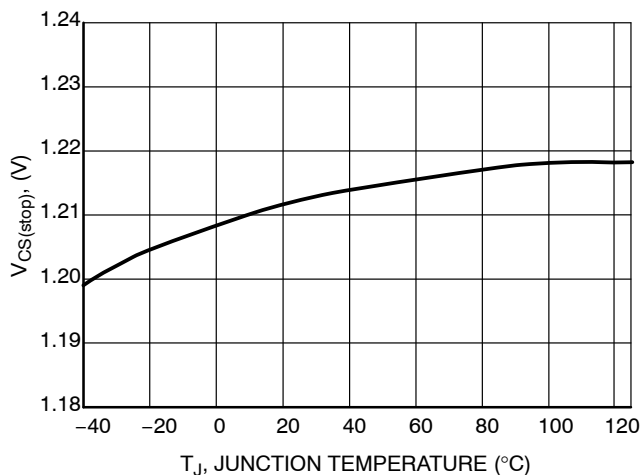

Figure 11.  $V_{CS(stop)}$  vs. Junction Temperature

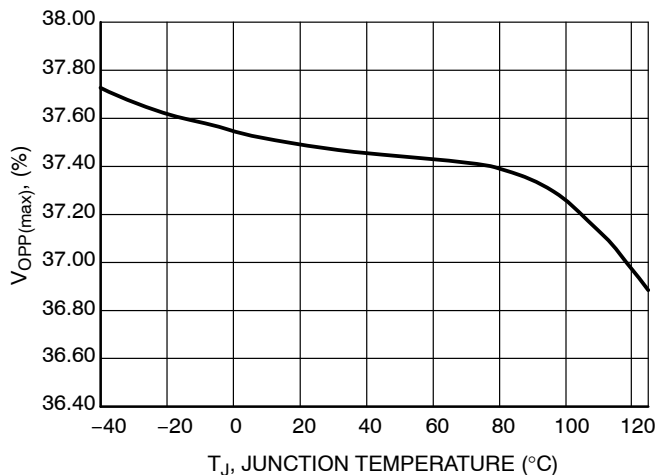

Figure 12.  $V_{OPP(MAX)}$  vs. Junction Temperature

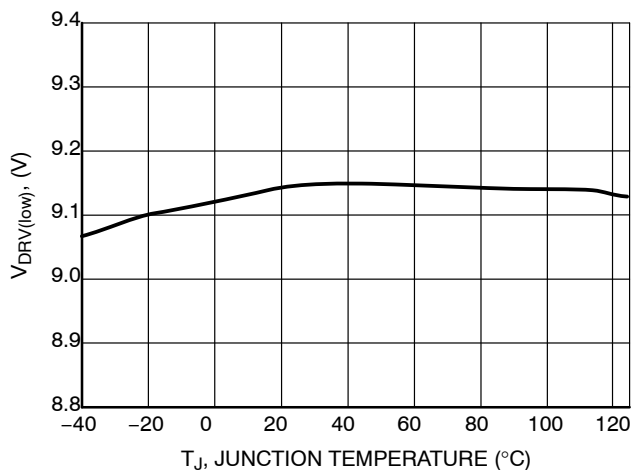

Figure 13.  $V_{DRV(low)}$  vs. Junction Temperature

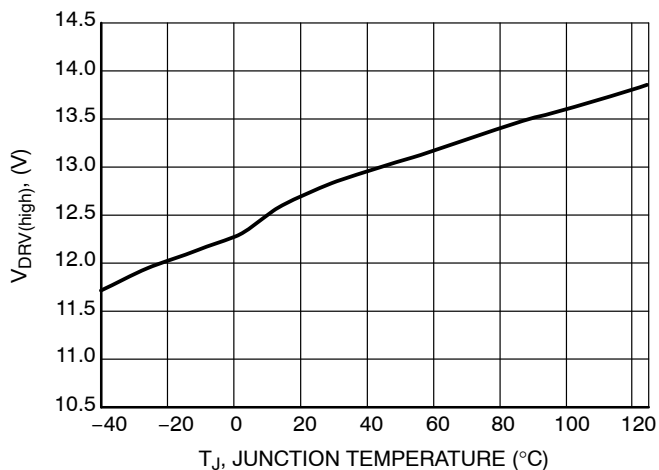

Figure 14.  $V_{DRV(high)}$  vs. Junction Temperature



# NCP1379

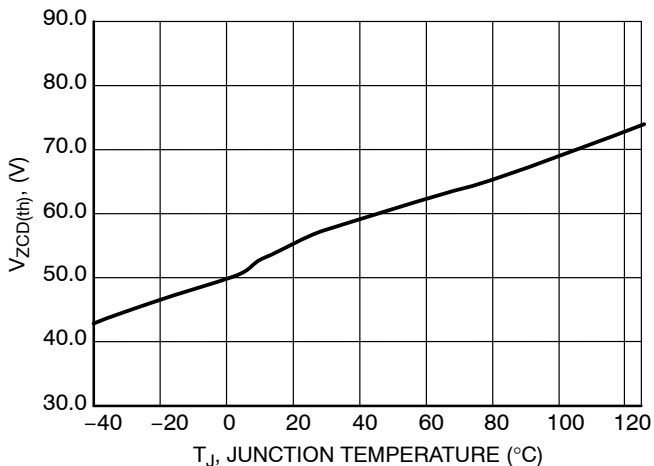

Figure 15.  $V_{ZCD(th)}$  vs. Junction Temperature

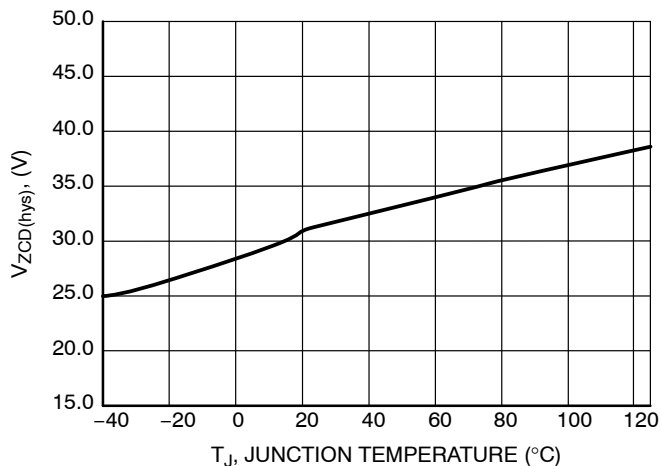

Figure 16.  $V_{ZCD(hys)}$  vs. Junction Temperature

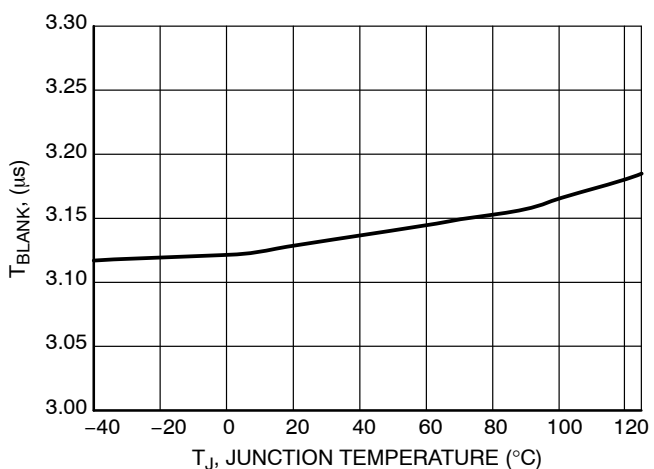

Figure 17.  $T_{BLANK}$  vs. Junction Temperature

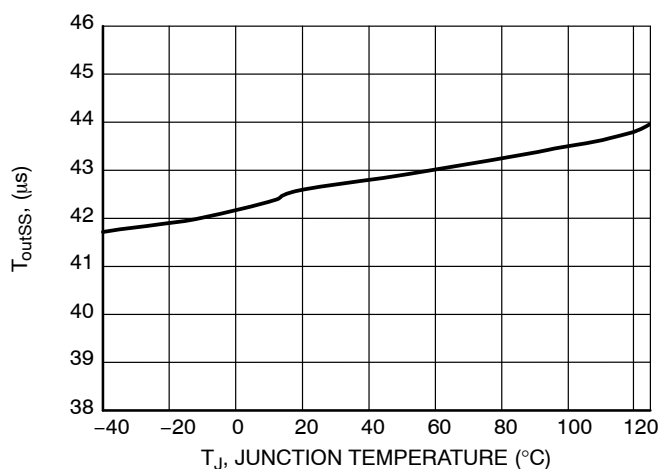

Figure 18.  $T_{outSS}$  vs. Junction Temperature

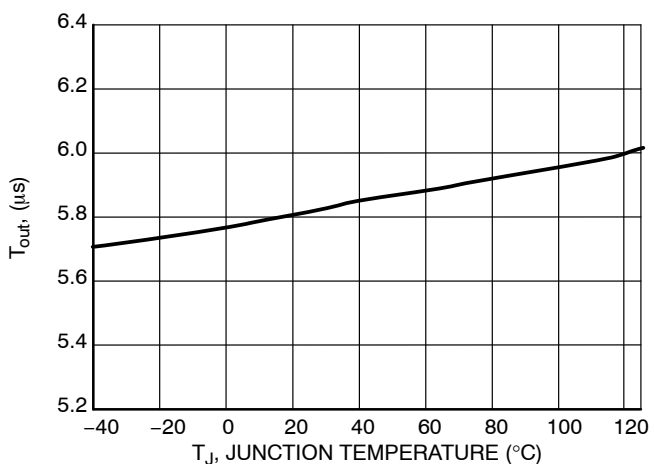

Figure 19.  $T_{out}$  vs. Junction Temperature

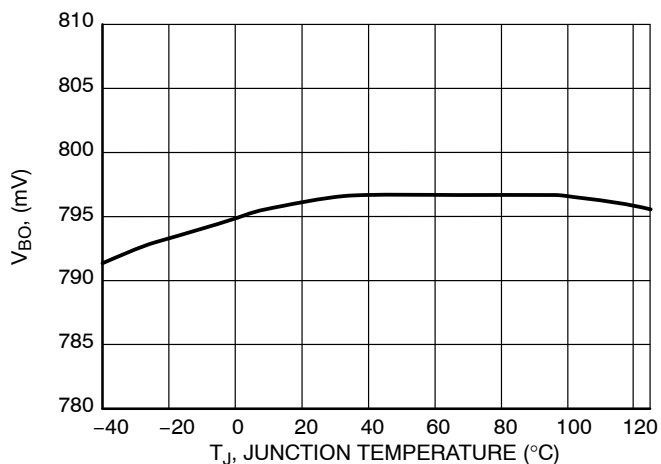

Figure 20.  $V_{BO}$  vs. Junction Temperature

## NCP1379

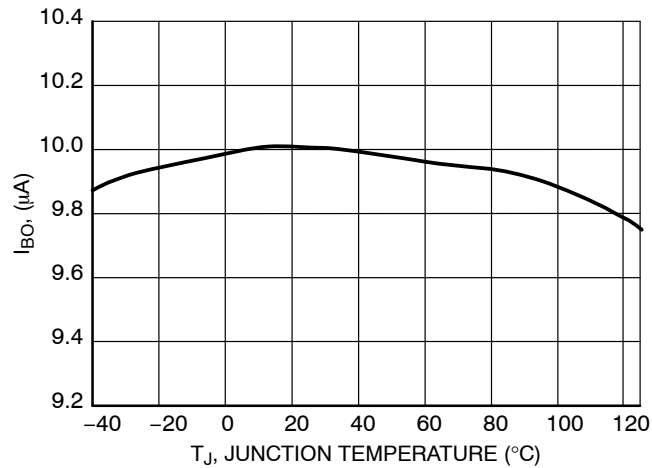

Figure 21.  $I_{BO}$  vs. Junction Temperature

### APPLICATION INFORMATION

NCP1379 implements a standard current-mode architecture operating in quasi-resonant mode. Thanks to a proprietary circuitry, the controller prevents valley-jumping instability and steadily locks out in selected valley as the power demand goes down. Once the fourth valley is reached, the controller continues to reduce the frequency further down, offering excellent efficiency over a wide operating range. Due to a fault timer combined to an OPP circuitry, the controller is able to efficiently limit the output power at high-line.

- Quasi-Resonance Current-mode operation: implementing quasi-resonance operation in peak current-mode control, the NCP1379 optimizes the efficiency by switching in the valley of the MOSFET drain-source voltage. Due to a proprietary circuitry, the controller locks-out in a selected valley and remains locked until the output loading significantly changes. This behavior is obtained by monitoring the feedback voltage. When the load becomes lighter, the feedback setpoint changes and the controller jumps into the next valley. It can go down to the 4<sup>th</sup> valley if necessary. Beyond this point, the controller reduces its switching frequency by freezing the peak current setpoint. During quasi-resonance operation, in case of very damped valleys, a 5.9  $\mu s$  timer adds the missing valleys.
- Frequency reduction in light-load conditions: when the 4<sup>th</sup> valley is left, the controller reduces the switching frequency which naturally improves the standby power by a reduction of all switching losses.

- Overpower protection (OPP): When the voltage on ZCD pin swings in flyback polarity, a direct image of the input voltage is applied on ZCD pin. We can thus reduce the peak current depending of the ZCD pin voltage level during the on-time.
- Internal soft-start: a soft-start precludes the main power switch from being stressed upon start-up. Its duration is fixed and equal to 3.8 ms.
- Fault input: the NCP1379 and D versions include a brown-out circuit which safely stops the controller in case the input voltage is too low. Restart occurs via a complete startup sequence (latch reset and soft-start). During normal operation, the voltage on this pin is clamped to 1.2 V to give enough room for OVP detection. If the voltage on this pin increases above 2.5 V, the part latches-off.
- Short-circuit protection: short-circuit and especially over-load protections are difficult to implement when a strong leakage inductance between auxiliary and power windings affects the transformer (where the auxiliary winding level does not properly collapse in presence of an output short). Here, when the internal 0.8 V maximum peak current limit is activated, the timer starts counting up. If the fault disappears, the timer counts down. If the timer reaches completion while the error flag is still present, the controller stops the pulses and goes into auto-recovery mode.

NCP1379 OPERATING MODES

NCP1379 has two operating mode: quasi-resonant operation and VCO operation for the frequency foldback.

The operating mode is fixed by the FB voltage as portrayed by Figure 22:

- Quasi-resonant operation occurs for FB voltage higher than 0.8 V (FB decreasing) or higher than 1.4 V (FB increasing) which correspond to high output power and medium output power. The peak current is variable and is set by the FB voltage divided by 4.
- Frequency foldback or VCO mode occurs for FB voltage lower than 0.8 V (FB decreasing) or lower than 1.4 V (FB increasing). This corresponds to low output power.

- During VCO mode, the peak current decreases down to 17.5% of its maximum value and is then frozen. The switching frequency is variable and decreases as the output load decreases.
- The switching frequency is set by the end of charge of the capacitor connected to the  $C_T$  pin. This capacitor is charged with a constant current source and the capacitor voltage is compared to an internal threshold fixed by FB voltage. When this capacitor voltage reaches the threshold the capacitor is rapidly discharged down to 0 V and a new period start.

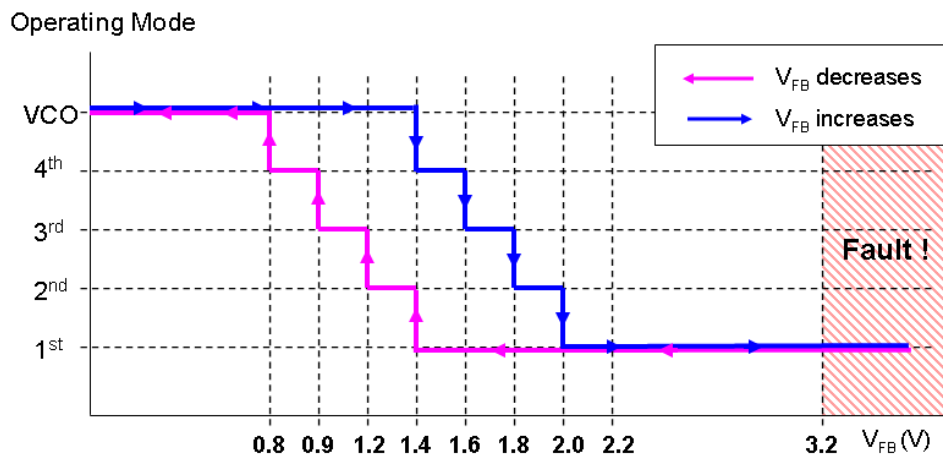

Figure 22. Operating Valley According to FB Voltage

VALLEY DETECTION AND SELECTION

The valley detection is done by monitoring the voltage of the auxiliary winding of the transformer. A valley is detected when the voltage on pin 1 crosses down the 55 mV internal

threshold. When a valley is detected, an internal counter is incremented. The operating valley (1<sup>st</sup>, 2<sup>nd</sup>, 3<sup>rd</sup> or 4<sup>th</sup>) is determined by the FB voltage as shown by Figure 22.

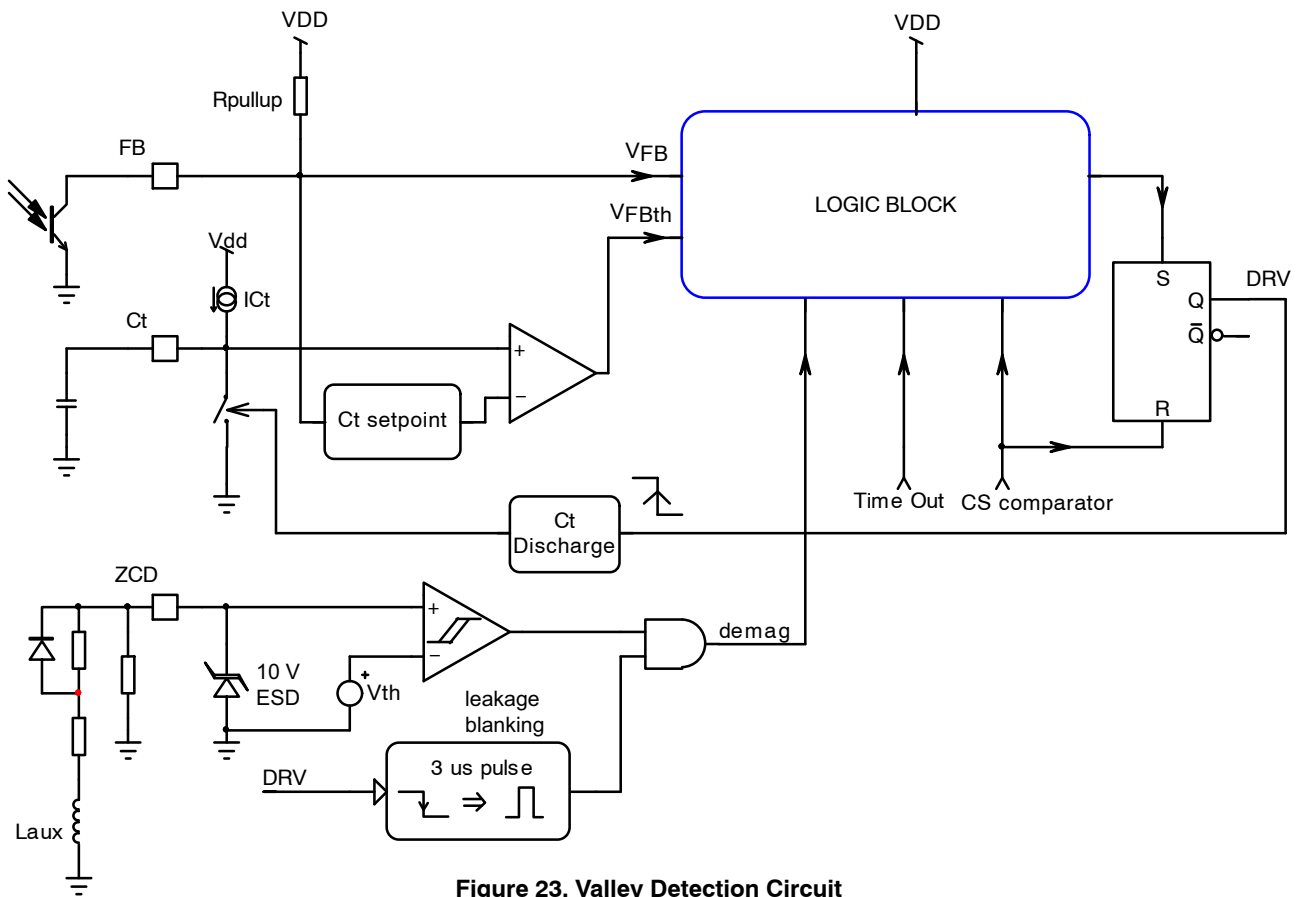

Figure 23. Valley Detection Circuit

As the output load decreases (FB voltage decreases the valleys are incremented from the first to the fourth. When the fourth valley is reached, if FB voltage further decreases below 0.8 V, the controller enters VCO mode.

During VCO operation, the peak current continues to decrease until it reaches 17.5% of the maximum peak current: the switching frequency expands to deliver the

necessary output power. This allows achieving very low standby power consumption.

The Figure 24 shows a simulation case where the output current of a 19 V / 60 W decreases from 2.8 A to 0.1 A. No instability is seen during the valley transitions (Figures 25, 26, 27 and 28)

# NCP1379

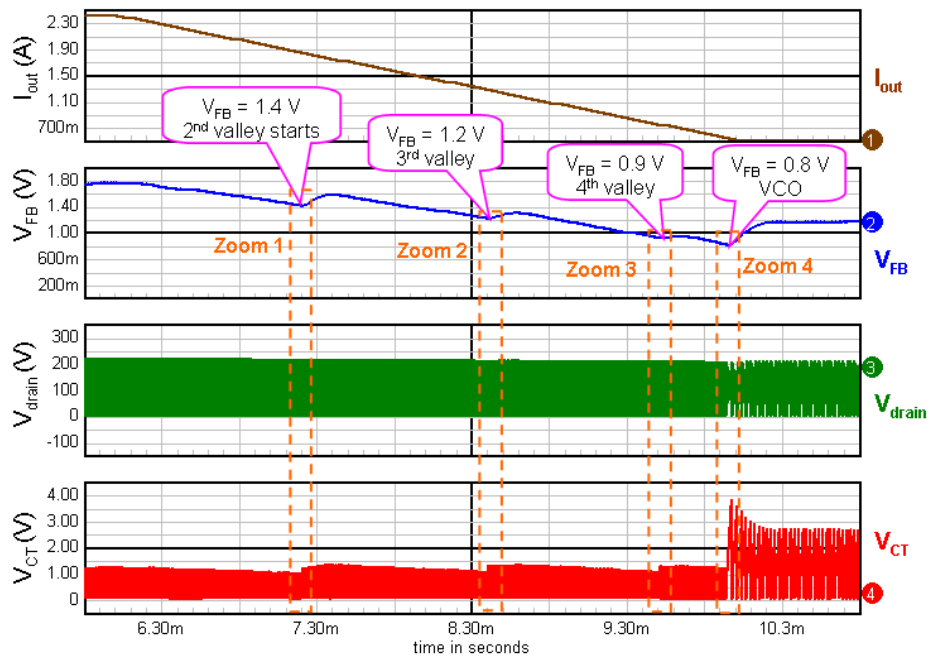

Figure 24. Output Load is Decreased from 2.4 A to 0.5 A at 120 Vdc Input Voltage

# NCP1379

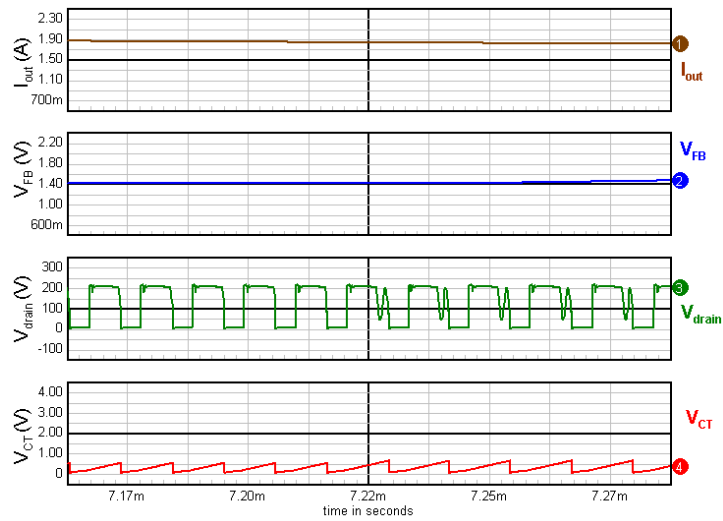

Figure 25. Zoom 1: 1<sup>st</sup> to 2<sup>nd</sup> Valley Transition

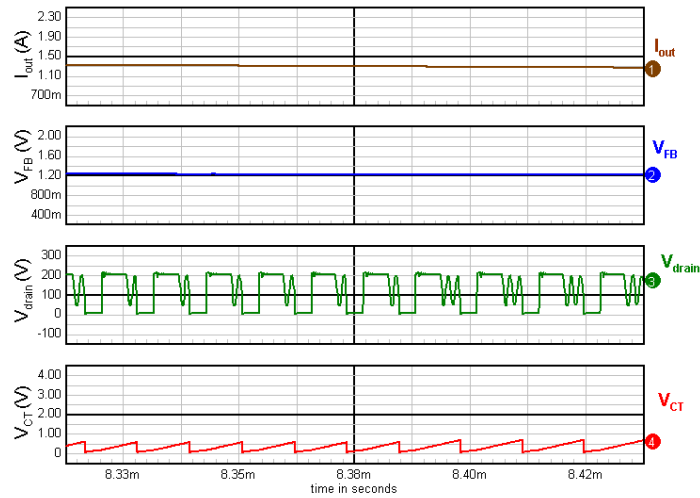
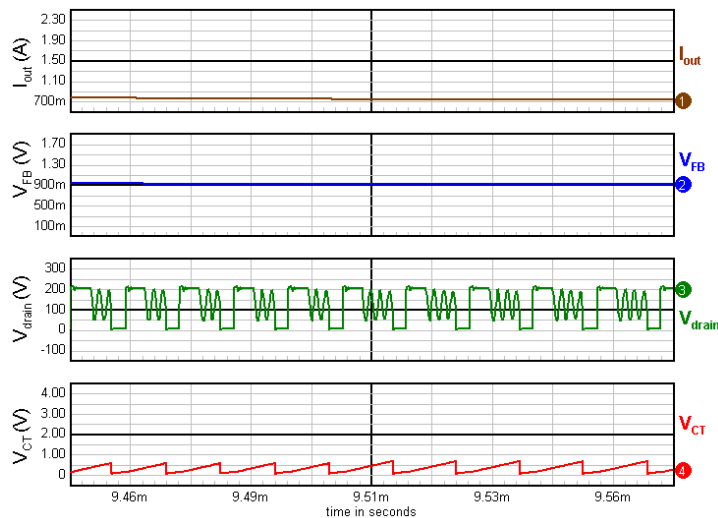
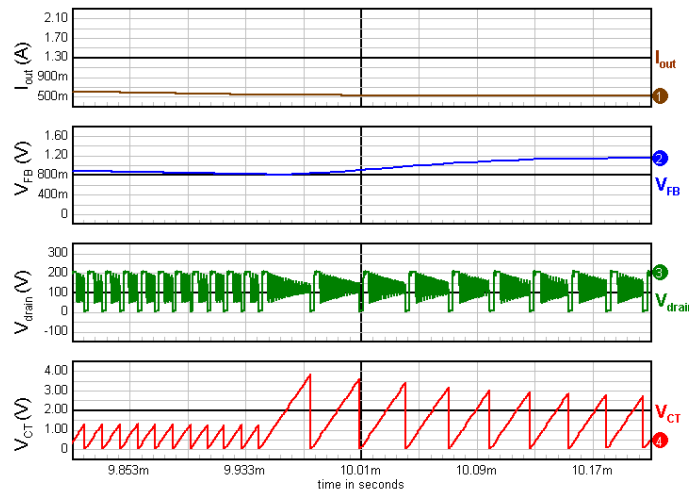

Figure 26. Zoom 2: 2<sup>nd</sup> to 3<sup>rd</sup> Valley Transition

# NCP1379



**Figure 27. Zoom 3: 3<sup>rd</sup> to 4<sup>th</sup> Valley Transition**



**Figure 28. Zoom 4: 4<sup>th</sup> Valley to VCO Mode Transition**

## Time Out

In case of extremely damped free oscillations, the ZCD comparator can be unable to detect the valleys. To avoid such situation, NCP1379 integrates a Time Out function that acts as a substitute clock for the decimal counter inside the logic bloc. The controller thus continues its normal operation. To avoid having a too big step in frequency, the time out duration is set to 5.9  $\mu$ s. Figures 30 and 31 detail the time out operation.

The NCP1379 also features an extended time out during the soft-start.

Indeed, at startup, the output voltage reflected on the auxiliary winding is low. Because of the voltage drop

introduced by the Over Power Compensation diode (Figure 35), the voltage on the ZCD pin is very low and the ZCD comparator might be unable to detect the valleys. In this condition, setting the DRV Latch with the 5.9  $\mu$ s time-out leads to a continuous conduction mode operation (CCM) at the beginning of the soft-start. This CCM operation only last a few cycles until the voltage on ZCD pin becomes high enough to be detected by the ZCD comparator.

To avoid this, the time-out duration is extended to 40  $\mu$ s during the soft-start in order to ensure that the transformer is fully demagnetized before the MOSFET is turned-on.

# NCP1379

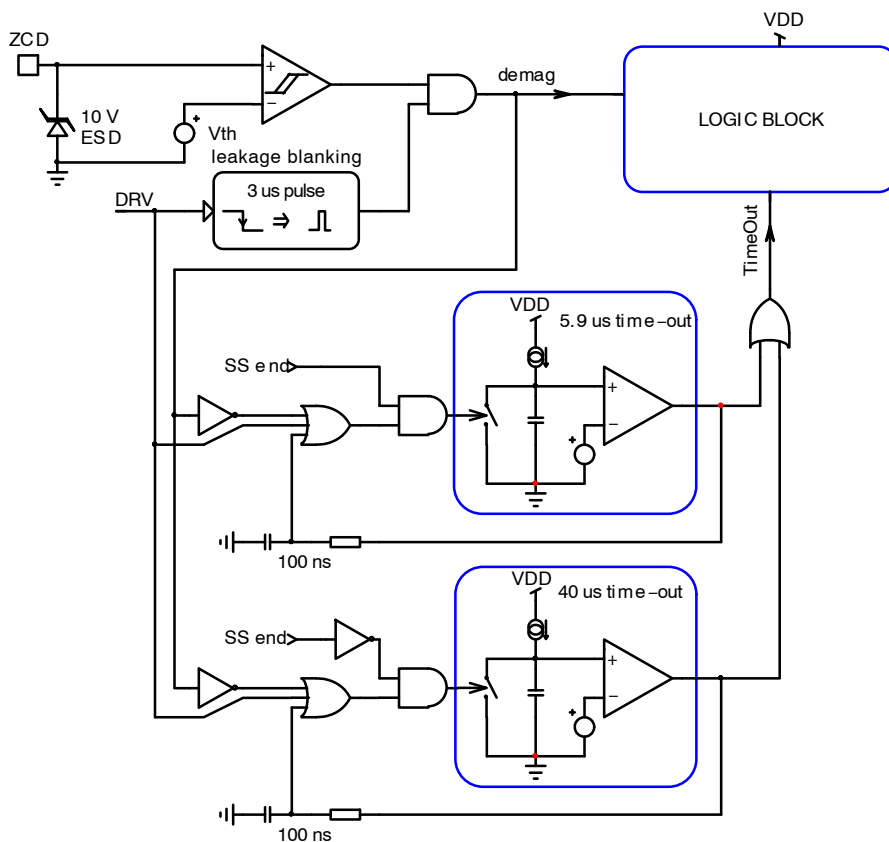

Figure 29. Time Out Circuit

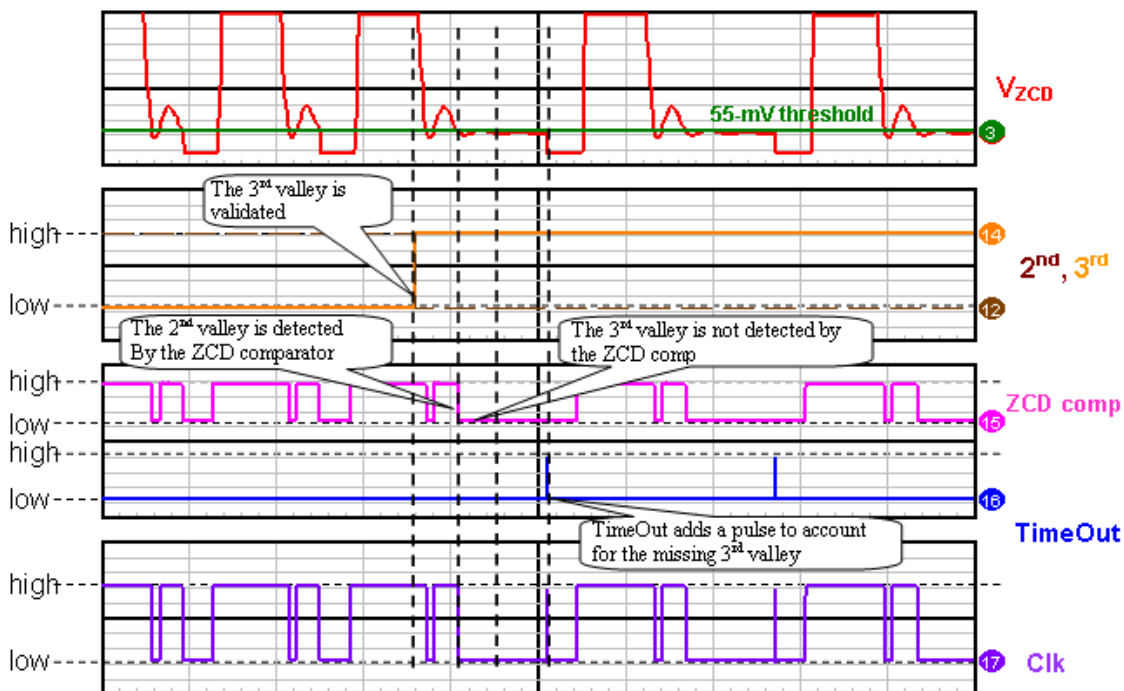

Figure 30. Time Out Case n°1: the 3<sup>rd</sup> Valley is Missing



# NCP1379

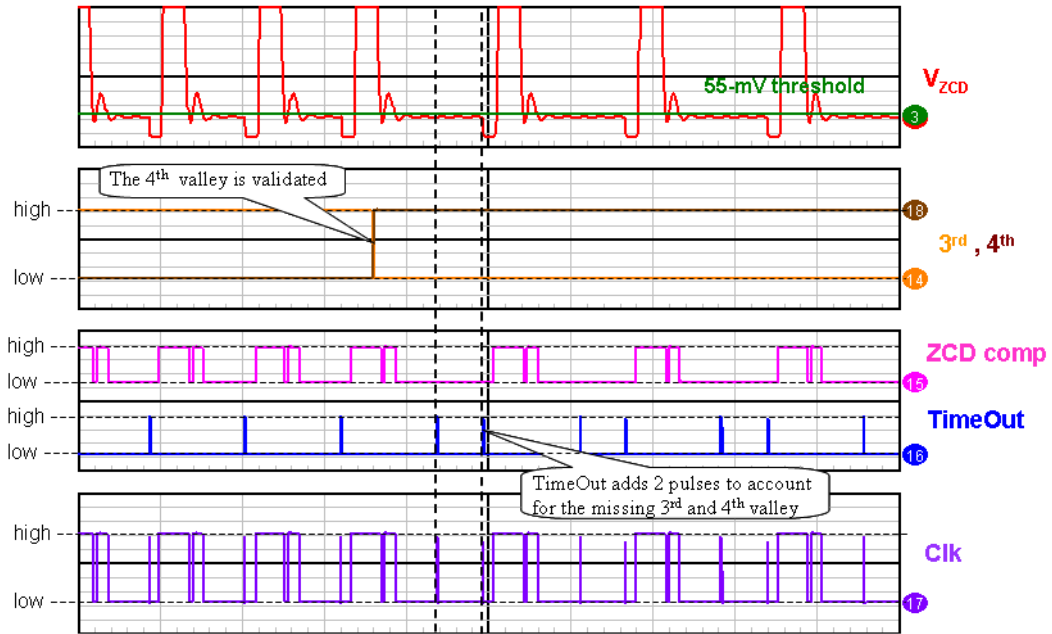

Figure 31. Time Out Case n°2: the 3<sup>rd</sup> and 4<sup>th</sup> Valley are Missing

## VCO MODE

VCO operation occurs for FB voltage lower than 0.8 V (FB decreasing), or lower than 1.4 V (FB increasing). This corresponds to low output power.

During VCO operation, the switching frequency is variable and expands as the output power decreases. The peak current is fixed to 17.5% of his maximum value when  $V_{FB} < 0.56$  V.

The frequency is set by the end of charge of the capacitor connected to the C<sub>T</sub> pin. This capacitor is charged with a constant current source and its voltage is compared to an internal threshold ( $V_{FBth}$ ) fixed by FB voltage (see

Figure 23). When this capacitor voltage reaches the threshold, the capacitor is rapidly discharged down to 0 V and a new period start. The internal threshold is inversely proportional to FB voltage. The relationship between  $V_{FB}$  and  $V_{FBth}$  is given by Equation 1.

$$V_{FBth} = 6.5 - (10/3)V_{FB} \quad (\text{eq. 1})$$

When  $V_{FB}$  is lower than 0.3 V,  $V_{CT}$  is clamped to  $V_{CT(MAX)}$  which is typically 5.5 V. Figure 32 shows the VCO mode at works.

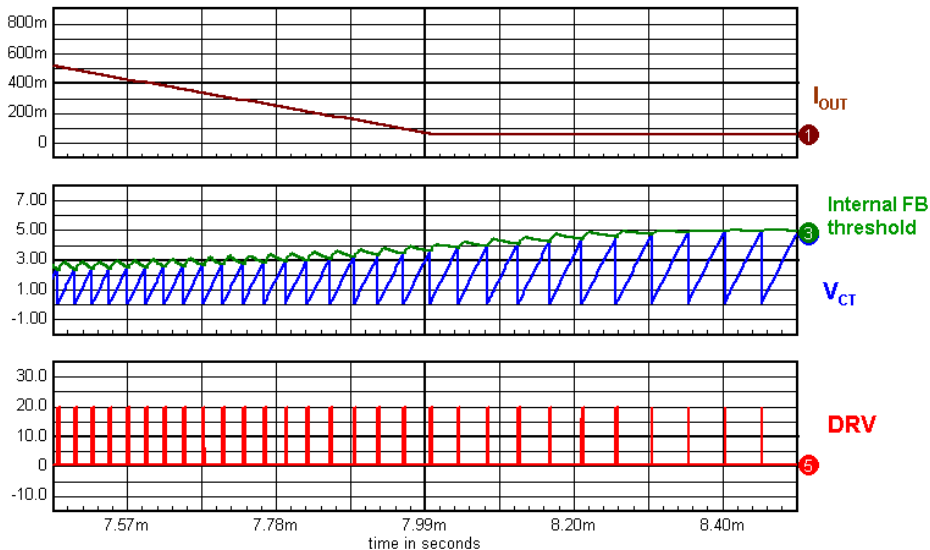

Figure 32. In VCO Mode, as the Power Output Decreases the Frequency Expands

SHORT-CIRCUIT OR OVERLOAD MODE

Figure 33 shows the implementation of the fault timer.

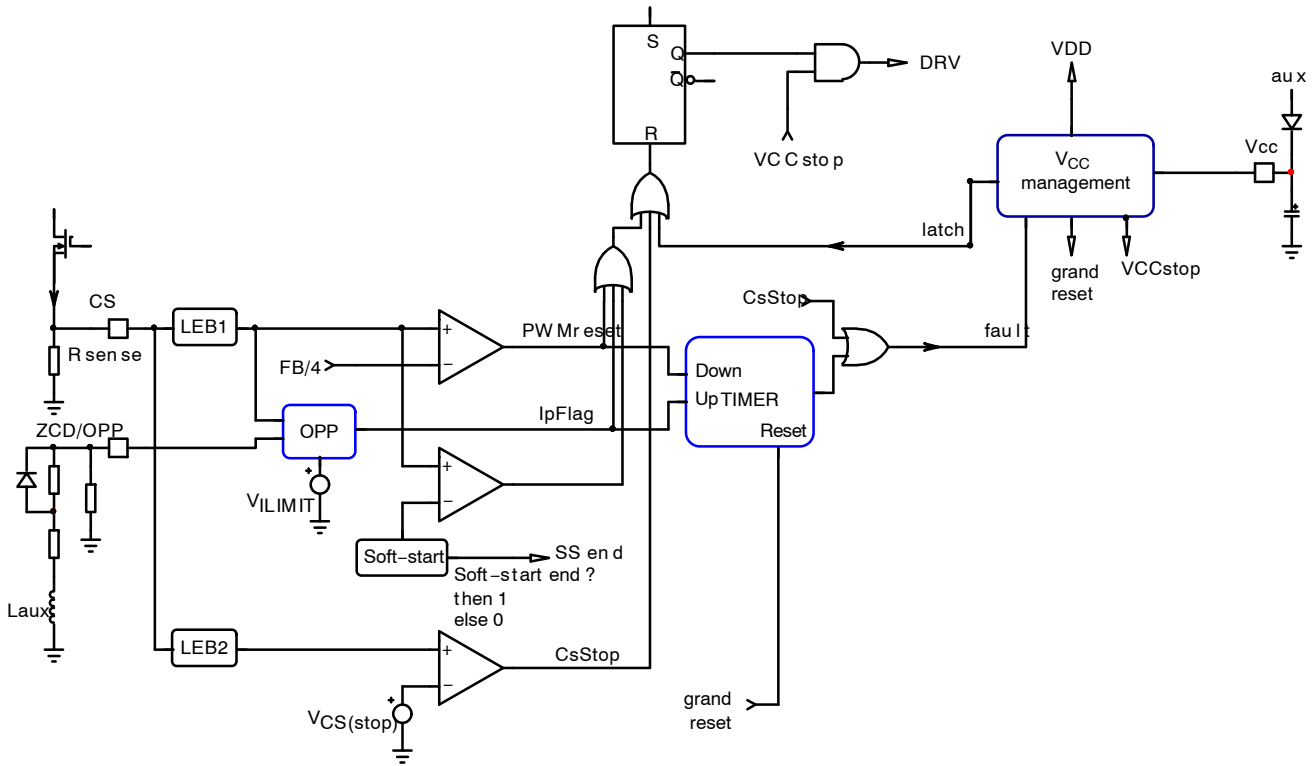

Figure 33. Fault Detection Schematic

When the current in the MOSFET is higher than  $V_{ILIMIT}/R_{sense}$ , “Max Ip” comparator trips and the digital timer starts counting: the timer count is incremented each 10 ms. When the current comes back within safe limits, “Max Ip” comparator becomes silent and the timer count down: the timer count is decremented each 10 ms. In normal overload conditions the timer reaches its completion when it has counted up 8 times 10 ms.

When the timers reaches its completion, the circuit enter auto-recovery mode: the circuit stops all operations during 1.2 s typically and re-start. This ensures a low duty-cycle burst operation in fault mode (around 6.7%).

In parallel to the cycle-by-cycle sensing of the CS pin, another comparator with a reduced LEB ( $t_{BCS}$ ) and a threshold of 1.2 V is able to sense winding short-circuit and immediately stop the controller. This additional protection is also auto-recovery.

# NCP1379

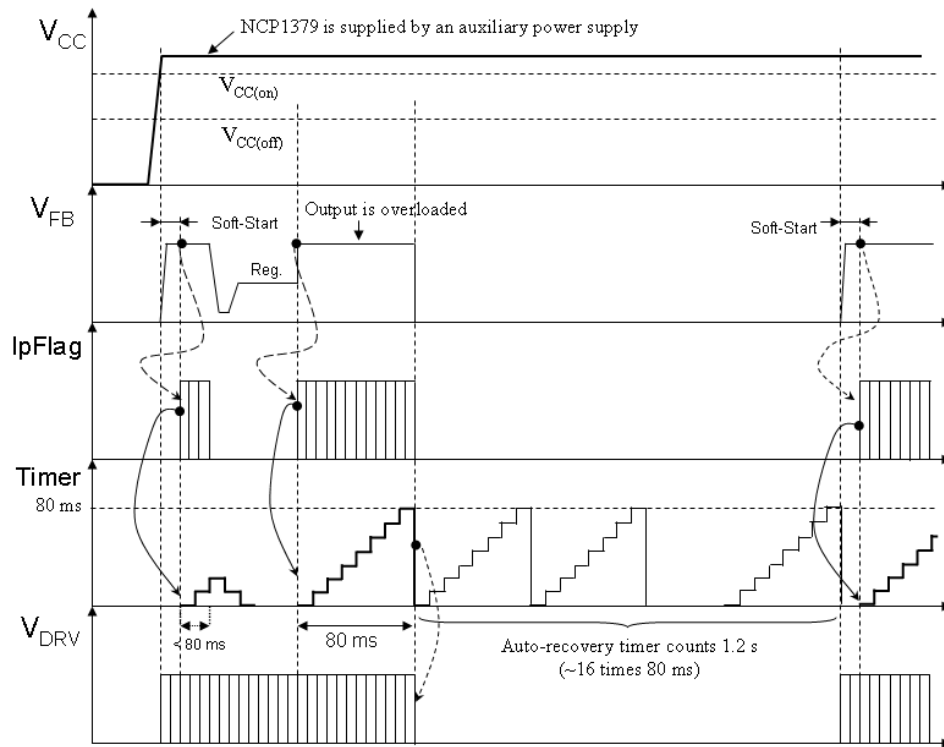

**Figure 34. Auto-Recovery Overload Protection Chronograms**

## OVER POWER COMPENSATION

The over power compensation is achieved by monitoring the signal on ZCD pin (pin 1). Indeed, a negative voltage applied on this pin directly affects the internal voltage reference setting the maximum peak current (Figure 35).

When the power MOSFET is turned-on, the auxiliary winding voltage becomes a negative voltage proportional to

the input voltage. As the auxiliary winding is already connected to ZCD pin for the valley detection, by selecting the right values for  $R_{opu}$  and  $R_{opl}$ , we can easily perform over power compensation.

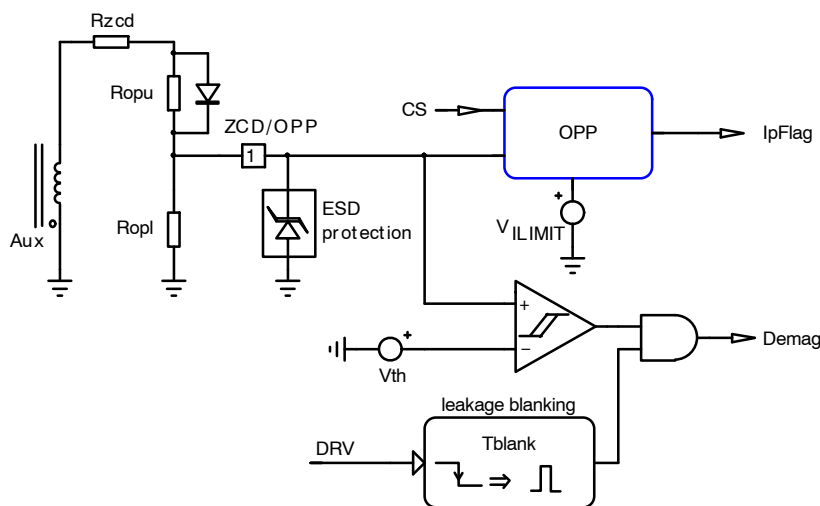

**Figure 35. Over Power Compensation Circuit**

To ensure optimal zero-crossing detection, a diode is needed to bypass  $R_{opu}$  during the off-time.

If we apply the resistor divider law on pin 1 during the on-time, we obtain the following relationship:

$$\frac{R_{ZCD} + R_{OpU}}{R_{OpI}} = -\frac{N_{p,aux}V_{IN} - V_{OPP}}{V_{OPP}} \quad (\text{eq. 2})$$

Where:

$N_{p,aux}$  is the auxiliary to primary turn ratio:  $N_{p,aux} = N_{aux} / N_p$

$V_{IN}$  is the DC input voltage

$V_{OPP}$  is the negative OPP voltage

By selecting a value for  $R_{OpI}$ , we can easily deduce  $R_{OpU}$  using Equation 2. While selecting the value for  $R_{OpI}$ , we must be careful not choosing a too low value for this resistor in order to have enough voltage for zero-crossing detection during the off-time. We recommend having at least 8 V on ZCD pin, the maximum voltage being 10 V.

During the off-time, ZCD pin voltage can be expressed as follows:

$$V_{ZCD} = \frac{R_{OpI}}{R_{ZCD} + R_{OpI}} (V_{aux} - V_d) \quad (\text{eq. 3})$$

We can thus deduce the relationship between  $R_{OpI}$  and  $R_{ZCD}$ :

$$\frac{R_{ZCD}}{R_{OpI}} = \frac{V_{aux} - V_d - V_{ZCD}}{V_{ZCD}} \quad (\text{eq. 4})$$

Design example:

- $V_{aux} = 18 \text{ V}$
- $V_d = 0.6 \text{ V}$
- $N_{p,aux} = 0.18$

If we want at least 8 V on ZCD pin, we have:

$$\frac{R_{ZCD}}{R_{OpI}} = \frac{V_{aux} - V_d - V_{ZCD}}{V_{ZCD}} = \frac{18 - 0.6 - 8}{8} = 1.2 \quad (\text{eq. 5})$$

We can choose:  $R_{ZCD} = 1 \text{ k}\Omega$  and  $R_{OpI} = 1 \text{ k}\Omega$ .

For the over power compensation, we need to decrease the peak current by 37.5% at high line (370 Vdc). The corresponding OPP voltage is:

$$V_{OPP} = 0.375 \times V_{ILIM} = -300 \text{ mV} \quad (\text{eq. 6})$$

Using Equation 2, we have:

$$\begin{aligned} \frac{R_{ZCD} + R_{OpU}}{R_{OpI}} &= -\frac{N_{p,aux}V_{IN} - V_{OPP}}{V_{OPP}} \\ &= \frac{-0.18 \times 370 - (-0.3)}{(-0.3)} = 221 \end{aligned} \quad (\text{eq. 7})$$

Thus,

$$R_{OpU} = 221 R_{OpI} - R_{ZCD} = 221 \times 1\text{k} - 1\text{k} = 220 \text{ k}\Omega \quad (\text{eq. 8})$$

### OVERVOLTAGE PROTECTION / BROWN-OUT

NCP1379 combine brown-out and overvoltage detection on the pin Fault.

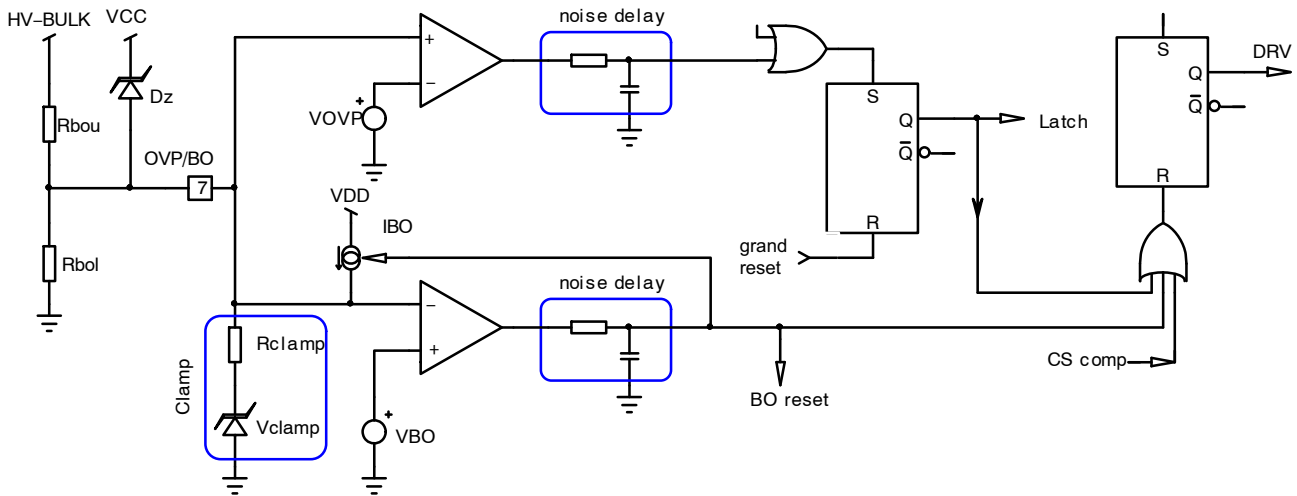

Figure 36. Brown-out and Overvoltage Protection

In order to protect the power supply against low input voltage condition, the pin 7 permanently monitors a fraction of the bulk voltage through a voltage divider. When this image of bulk voltage is below the  $V_{BO}$  threshold, the controller stops switching. When the bulk voltage comes back within safe limits, the circuit restarts pulsing. The hysteresis for the brown-out function is implemented with a high side current source sinking  $10 \mu\text{A}$  when the brown-out comparator is high ( $V_{bulk} > V_{bulk(on)}$ )

In order to avoid having a too high voltage on pin 7 if the bulk voltage is high, an internal clamp limits the voltage.

In case of over voltage, the zener diode will start to conduct and inject current inside the internal clamp resistor  $R_{clamp}$  thus causing pin 7 voltage to increase. When this voltage reaches  $V_{OVp}$  the controller latches-off and stays latched. The controller will be reset if  $V_{CC}$  falls bellow  $V_{CC(reset)}$  or if a brown-out occurs (Figure 37).

## NCP1379

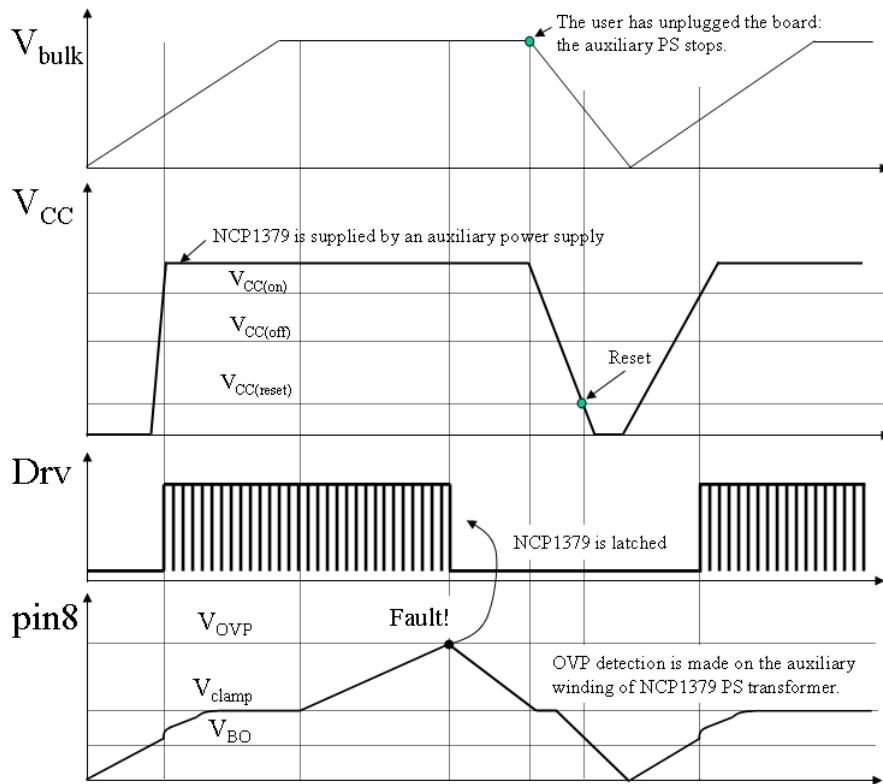

**Figure 37. Operating Chronograms in Case of Overvoltage with NCP1379 Supplied by an Auxiliary Power Supply**

The following equations show how to calculate the brown-out resistors.

First of all, select the bulk voltage value at which the controller must start switching ( $V_{\text{bulk(on)}}$ ) and the bulk voltage for shutdown ( $V_{\text{bulk(off)}}$ ). Then use the following equation to calculate  $R_{\text{bou}}$  and  $R_{\text{bol}}$ .

$$R_{\text{bol}} = \frac{V_{\text{BO}}(V_{\text{bulk(on)}} - V_{\text{bulk(off)}})}{I_{\text{BO}}(V_{\text{bulk(on)}} - V_{\text{BO}})} \quad (\text{eq. 9})$$

$$R_{\text{bou}} = \frac{R_{\text{bol}}(V_{\text{bulk(on)}} - V_{\text{BO}})}{V_{\text{BO}}} \quad (\text{eq. 10})$$

### DESIGN EXAMPLE

$$V_{\text{BO}} = 0.8 \text{ V}$$

$$I_{\text{BO}} = 10 \mu\text{A}$$

We select:  $V_{\text{bulk(on)}} = 120 \text{ V}$ ,  $V_{\text{bulk(off)}} = 60 \text{ V}$

$$R_{\text{bol}} = \frac{V_{\text{BO}}(V_{\text{bulk(on)}} - V_{\text{bulk(off)}})}{I_{\text{BO}}(V_{\text{bulk(on)}} - V_{\text{BO}})} \quad (\text{eq. 11})$$

$$= \frac{0.8(120 - 60)}{10 \times 10^{-6}(120 - 0.8)} = 40.3 \text{ k}\Omega$$

$$R_{\text{bou}} = \frac{R_{\text{bol}}(V_{\text{bulk(on)}} - V_{\text{BO}})}{V_{\text{BO}}} \quad (\text{eq. 12})$$

$$= \frac{40.3 \times 10^3(120 - 0.8)}{0.8} = 6 \text{ M}\Omega$$

### ORDERING INFORMATION

Device	Package Type	Shipping†
NCP1379DR2G	SOIC-8 (Pb free)	2500 / Tape & Reel

†For information on tape and reel specifications, including part orientation and tape sizes, please refer to our Tape and Reel Packaging Specifications Brochure, BRD8011/D.

# NCP1379

## PACKAGE DIMENSIONS

SOIC-8 NB  
CASE 751-07  
ISSUE AJ

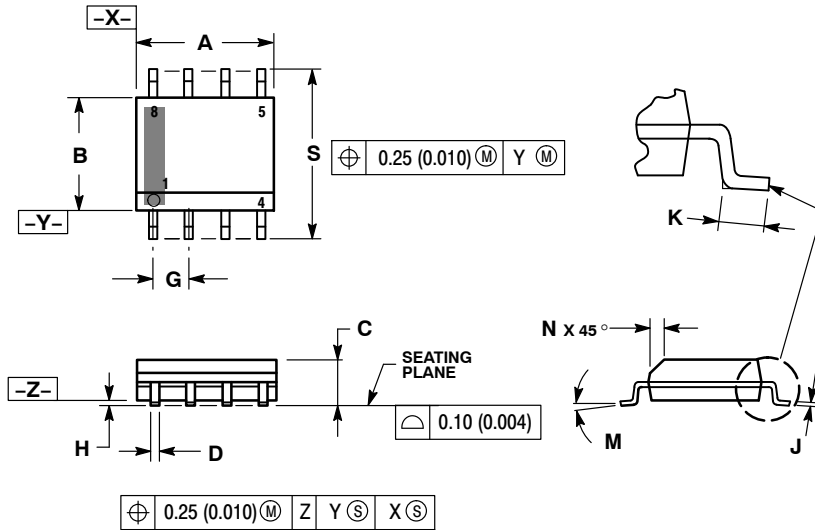

**NOTES:**

1. DIMENSIONING AND TOLERANCING PER ANSI Y14.5M, 1982.
2. CONTROLLING DIMENSION: MILLIMETER.
3. DIMENSION A AND B DO NOT INCLUDE MOLD PROTRUSION.
4. MAXIMUM MOLD PROTRUSION 0.15 (0.006) PER SIDE.
5. DIMENSION D DOES NOT INCLUDE DAMBAR PROTRUSION. ALLOWABLE DAMBAR PROTRUSION SHALL BE 0.127 (0.005) TOTAL IN EXCESS OF THE D DIMENSION AT MAXIMUM MATERIAL CONDITION.
6. 751-01 THRU 751-06 ARE OBSOLETE. NEW STANDARD IS 751-07.

DIM	MILLIMETERS		INCHES	
	MIN	MAX	MIN	MAX
A	4.80	5.00	0.189	0.197
B	3.80	4.00	0.150	0.157
C	1.35	1.75	0.053	0.069
D	0.33	0.51	0.013	0.020
G	1.27 BSC		0.050 BSC	
H	0.10	0.25	0.004	0.010
J	0.19	0.25	0.007	0.010
K	0.40	1.27	0.016	0.050
M	0°	8°	0°	8°
N	0.25	0.50	0.010	0.020
S	5.80	6.20	0.228	0.244

### SOLDERING FOOTPRINT\*

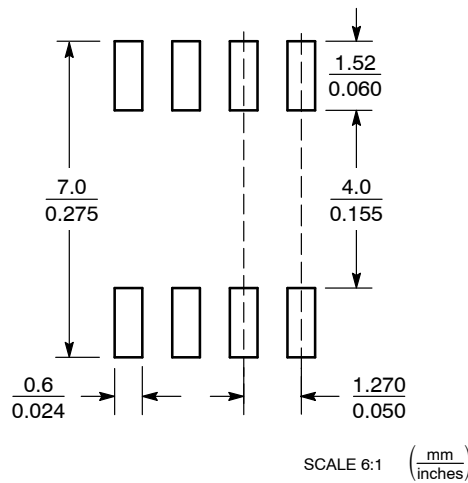

\*For additional information on our Pb-Free strategy and soldering details, please download the ON Semiconductor Soldering and Mounting Techniques Reference Manual, SOLDERRM/D.

The products described herein (NCP1379), may be covered by one or more of the following U.S. patents; 6,362,067 and 5,073,850. There may be other patents pending.

ON Semiconductor and are registered trademarks of Semiconductor Components Industries, LLC (SCILLC). SCILLC reserves the right to make changes without further notice to any products herein. SCILLC makes no warranty, representation or guarantee regarding the suitability of its products for any particular purpose, nor does SCILLC assume any liability arising out of the application or use of any product or circuit, and specifically disclaims any and all liability, including without limitation special, consequential or incidental damages. "Typical" parameters which may be provided in SCILLC data sheets and/or specifications can and do vary in different applications and actual performance may vary over time. All operating parameters, including "Typicals" must be validated for each customer application by customer's technical experts. SCILLC does not convey any license under its patent rights nor the rights of others. SCILLC products are not designed, intended, or authorized for use as components in systems intended for surgical implant into the body, or other applications intended to support or sustain life, or for any other application in which the failure of the SCILLC product could create a situation where personal injury or death may occur. Should Buyer purchase or use SCILLC products for any such unintended or unauthorized application, Buyer shall indemnify and hold SCILLC and its officers, employees, subsidiaries, affiliates, and distributors harmless against all claims, costs, damages, and expenses, and reasonable attorney fees arising out of, directly or indirectly, any claim of personal injury or death associated with such unintended or unauthorized use, even if such claim alleges that SCILLC was negligent regarding the design or manufacture of the part. SCILLC is an Equal Opportunity/Affirmative Action Employer. This literature is subject to all applicable copyright laws and is not for resale in any manner.

### PUBLICATION ORDERING INFORMATION

**LITERATURE FULFILLMENT:**  
Literature Distribution Center for ON Semiconductor  
P.O. Box 5163, Denver, Colorado 80217 USA  
**Phone:** 303-675-2175 or 800-344-3860 Toll Free USA/Canada  
**Fax:** 303-675-2176 or 800-344-3867 Toll Free USA/Canada  
**Email:** orderlit@onsemi.com

**N. American Technical Support:** 800-282-9855 Toll Free USA/Canada  
**Europe, Middle East and Africa Technical Support:**  
Phone: 421 33 790 2910  
**Japan Customer Focus Center**  
Phone: 81-3-5773-3850

**ON Semiconductor Website:** [www.onsemi.com](http://www.onsemi.com)  
**Order Literature:** <http://www.onsemi.com/orderlit>  
For additional information, please contact your local Sales Representative



Компания «ЭлектроПласт» предлагает заключение долгосрочных отношений при поставках импортных электронных компонентов на взаимовыгодных условиях!

Наши преимущества:

- Оперативные поставки широкого спектра электронных компонентов отечественного и импортного производства напрямую от производителей и с крупнейших мировых складов;
- Поставка более 17-ти миллионов наименований электронных компонентов;
- Поставка сложных, дефицитных, либо снятых с производства позиций;
- Оперативные сроки поставки под заказ (от 5 рабочих дней);
- Экспресс доставка в любую точку России;
- Техническая поддержка проекта, помощь в подборе аналогов, поставка прототипов;
- Система менеджмента качества сертифицирована по Международному стандарту ISO 9001;
- Лицензия ФСБ на осуществление работ с использованием сведений, составляющих государственную тайну;
- Поставка специализированных компонентов (Xilinx, Altera, Analog Devices, Intersil, Interpoint, Microsemi, Aeroflex, Peregrine, Syfer, Eurofarad, Texas Instrument, Miteq, Cobham, E2V, MA-COM, Hittite, Mini-Circuits, General Dynamics и др.);

Помимо этого, одним из направлений компании «ЭлектроПласт» является направление «Источники питания». Мы предлагаем Вам помощь Конструкторского отдела:

- Подбор оптимального решения, техническое обоснование при выборе компонента;
- Подбор аналогов;
- Консультации по применению компонента;
- Поставка образцов и прототипов;
- Техническая поддержка проекта;
- Защита от снятия компонента с производства.



#### Как с нами связаться

**Телефон:** 8 (812) 309 58 32 (многоканальный)

**Факс:** 8 (812) 320-02-42

**Электронная почта:** [org@eplast1.ru](mailto:org@eplast1.ru)

**Адрес:** 198099, г. Санкт-Петербург, ул. Калинина, дом 2, корпус 4, литера А.