

DIO2624

2-Vrms Audio Driver with Integrated 4-ch, 6th-Order SD and 1080i HD Video Filter

Features

- Line Output: able to drive 600Ω and 10kΩ
 - 2-Vrms With 3.3V Supply Voltage
 - No Pop/Clicks Noise at the line output when Power ON/OFF
 - No Need for Output DC-Blocking Capacitors
 - Accepting Differential Input
- Optimized Frequency Response between 20Hz–20kHz
- Video Filter: One CVBS channel with 6th-order, 9MHz filter
- Three channels with per channel a 6th-order, 37MHz filter
 - Drive Dual Video Load
 - Transparent Input Clamping
 - AC or DC Coupled Inputs/Outputs

Applications

- DVD Players
- Video Amplifiers
- Set-Top Boxes
- Personal Video Recorders
- Communications Devices

Ordering Information

| Order Part Number | Top Marking | | T _A | Package | |
|-------------------|-------------|------------|----------------|-------------|-------------------|
| DIO2624XT28 | DIO2624 | Green/RoHS | -40 to +85°C | EP-TSSOP-28 | Tape & Reel, 2500 |
| DIO2624CT24 | DIO2624 | Green/RoHS | -40 to +85°C | TSSOP-24 | Tape & Reel, 2500 |

Descriptions

The DIO2624 is an integrated solution for Video driver and Audio driver, with two separated modules, the Audio Driver module and 4-ch 6th-order SD and 1080i HD Video filter driver module.

The Audio Driver allow for the removal of output AC-coupling capacitors. It is designed to optimize the audio driver circuit performance while reducing the BOM cost by eliminating the peripheral discrete components for noise reduction. Featuring differential input mode, gain range of ±1V/V to ±10V/V can be achieved via external gain resistor setting.

The Video filter integrates a single CVBS (SD) video driver plus a triple 1080i HD video driver. It can improve image quality compared to the passive LC filters. All channels can be directly driven by a DC-coupled or an AC-coupled signal. Internal diode-like clamps and bias circuitry may be used if AC-coupled inputs are required. The output in the video filter can also drive AC or DC coupled single (150Ω) or dual (75Ω) loads. The DC coupling capacitors can be removed.

Pin Assignments

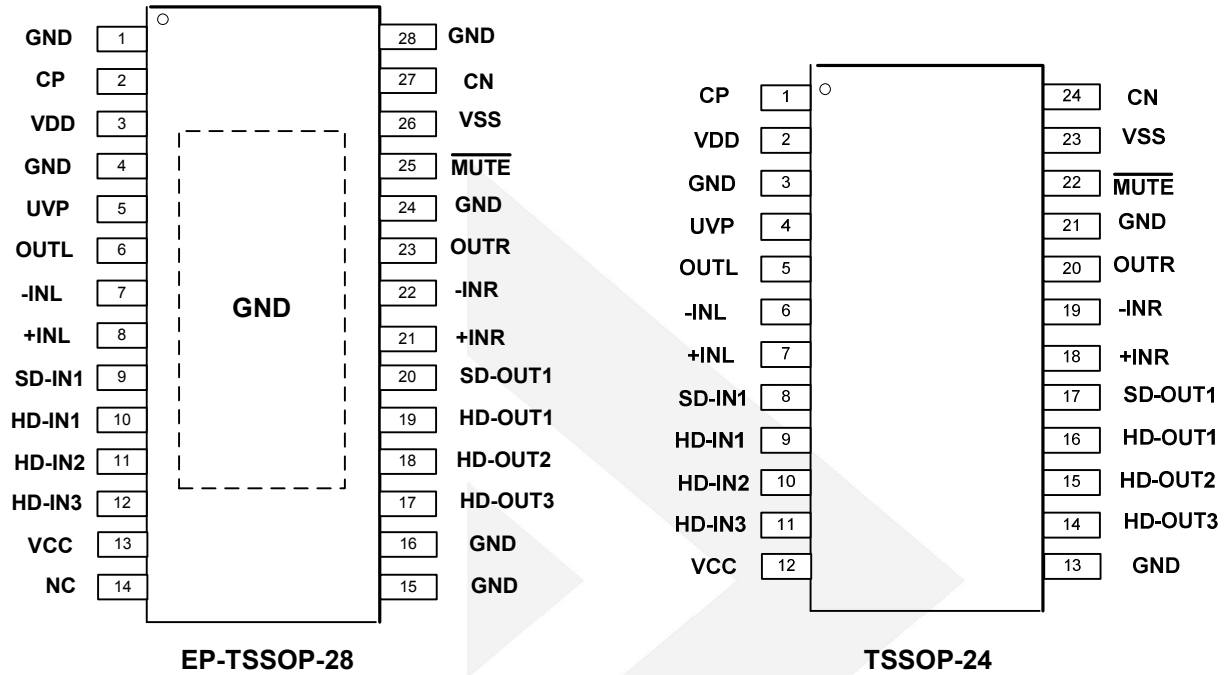

Figure 1 Pin Assignment

Pin Description

| Pin Name | Description |
|----------|--|
| GND | GND |
| CP | Charge-pump flying capacitor positive terminal |
| VDD | Audio line driver positive supply |
| UVP | Under voltage protection input |
| OUTL | Left channel Output |
| -INL | Left channel Negative Input |
| +INL | Left channel Positive Input |
| SD-IN1 | Channel SD Video Input |
| HD-IN1 | Channel HD Video Input (Pr) |
| HD-IN2 | Channel HD Video Input (Pb) |
| HD-IN3 | Channel HD Video Input (Y) |
| VCC | Video filter driver power supply |
| HD-OUT3 | Channel HD Video Output (Y) |
| HD-OUT2 | Channel HD Video Output (Pb) |
| HD-OUT1 | Channel HD Video Output (Pr) |
| SD-OUT1 | Channel SD Video Output |
| +INR | Right channel Positive Input |
| -INR | Right channel Negative Input |
| OUTR | Right channel Output |
| MUTE | Mute input, active-low |
| VSS | Supply voltage output |
| CN | Charge-pump flying capacitor negative terminal |
| NC | No connect |



DIO2624

2-Vrms Audio Driver with Integrated 4-ch 6th-Order SD/HD Video Filter

Block Diagram

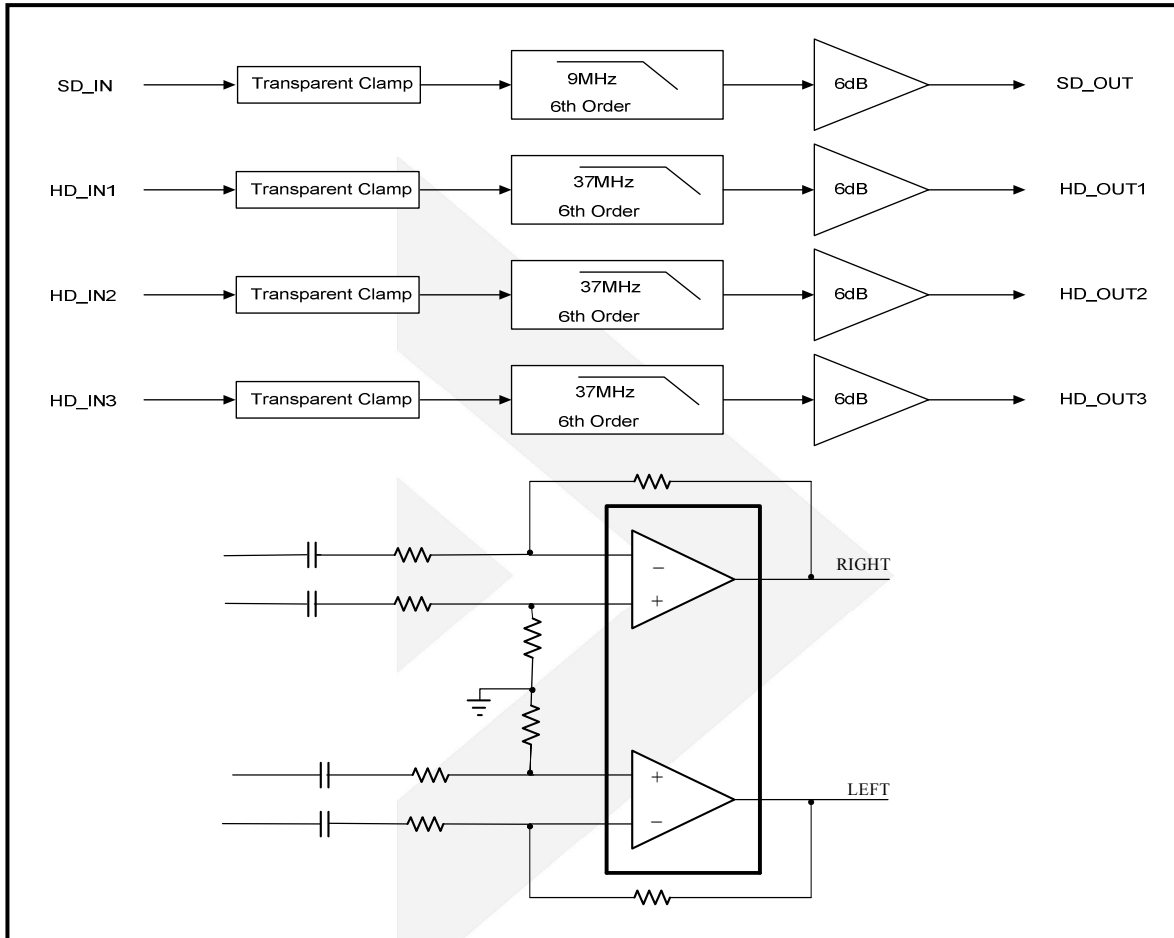

Absolute Maximum Ratings

Stresses beyond those listed under "Absolute Maximum Rating" may cause permanent damage to the device. These are stress ratings only and functional operation of the device at these or any other condition beyond those indicated in the operational sections of the specifications is not implied. Exposure to absolute maximum rating conditions for extended periods may affect device reliability.

| Parameter | Rating | Unit |
|----------------------------|------------------------------|--------------------|
| Supply Voltage/VCC | 0 to 6.0 | V |
| Supply Voltage/VDD | -0.3 to 4 | V |
| Input Voltage/VIN | -0.3 to $V_{CC}+0.3$ | V |
| Input Voltage/-INR,-INL | $V_{SS}-0.3$ to $V_{DD}+0.3$ | V |
| Minimum load impedance | 600 | Ω |
| $Mut\bar{e}$ to GND | -0.3 to $V_{DD}+0.3$ | V |
| Storage Temperature Range | -65 to 150 | $^{\circ}\text{C}$ |
| Junction Temperature | 150 | $^{\circ}\text{C}$ |
| Lead Temperature Range | 260 | $^{\circ}\text{C}$ |
| HBM ESD JEDEC: JESD22-A114 | 5 | kV |



DIO2624

2-Vrms Audio Driver with Integrated 4-ch 6th-Order SD/HD Video Filter

Recommended Operating Conditions

The Recommended Operating Conditions table defines the conditions for actual device operation to ensure optimal performance to the datasheet specifications. DIOO does not recommend exceeding them or designing to Absolute Maximum Ratings.

| Symbol | Parameter | Min. | Typ. | Max. | Unit |
|-----------------|-------------------------------|-------|------|------|----------------------|
| VDD | Supply Voltage | 3 | 3.3 | 3.6 | V |
| VCC | Supply Voltage | 3.135 | | 5.25 | V |
| V _{IH} | Mute High level Input Voltage | | 60 | | % of V _{DD} |
| V _{IL} | Mute Low level Input Voltage | | 40 | | % of V _{DD} |
| T _A | Operating Temperature Range | -40 | | 85 | °C |

Notes: The items below were divided into two parts, the Audio driver module and the Video filter module.

Electrical Characteristics for the Audio Driver module

Typical value: T_A = 25°C, V_{DD}=3.3V, R_L=10kΩ, C_{PUMP}=C_{PVSS}=1μF, R_{IN}=15kΩ, R_{fb}=30kΩ, unless otherwise specified.

| Symbol | Parameter | Conditions | Min. | Typ. | Max. | Unit |
|-------------------|---|--|------|-------|-------|-------------------|
| V _{OS} | Output Offset Voltage | V _{DD} =3.3V, Input grounded, Unity gain | | 0.8 | | mV |
| PSRR | Power supply rejection ratio | V _{DD} =3.3V | | 90 | | dB |
| V _{OH} | High level output voltage | V _{DD} =3.3V, R _L =10kΩ | 3.1 | | | V |
| V _{OL} | Low level output voltage | V _{DD} =3.3V, R _L =10kΩ | | | -3.05 | V |
| I _{IH} | Mute High level input current | V _{DD} =3.3V, V _I =V _{DD} | | | 1 | μA |
| I _{IL} | Mute Low level input current | V _{DD} =3.3V, V _I =0V | | | 1 | μA |
| I _{DD} | Supply current | V _{DD} =3.3V, V _I =V _{DD} , No load | | 16 | | mA |
| | | Mute mode, V _{DD} =3.3V | | 0.8 | | |
| V _O | Output Voltage | THD+N=1%, V _{DD} =3.3V, f=1kHz | 2.0 | 2.3 | | V _{RMS} |
| THD+N | Total harmonic distortion + noise | V _O =2V _{RMS} , f=1kHz | | 0.001 | | % |
| X _{TALK} | Channel crosstalk | V _O =2V _{RMS} | | -105 | | dB |
| SNR | Signal noise ratio | A-weighted | 90 | 105 | | dB |
| DNR | Dynamic range | A-weighted | | 105 | | dB |
| C _L | Maximum capacitive load | | | 220 | | pF |
| V _N | Noise output voltage | A-weighted | | 10 | | μV _{RMS} |
| G _{BW} | Unity gain bandwidth | | | 7.2 | | MHz |
| A _{VO} | Open loop voltage gain | | | 165 | | dB |
| V _{UVP} | External under-voltage detection | | | 1.25 | 1.325 | V |
| I _{Hys} | External under-voltage detection hysteresis current | | | 6 | | μA |
| f _{CP} | Charge pump frequency | | | 300 | | kHz |



DIO2624

2-Vrms Audio Driver with Integrated 4-ch 6th-Order SD/HD Video Filter

Electrical Characteristics for the Video Filter module

Typical value: $T_A = 25^\circ\text{C}$, $V_{CC}=5\text{V}$, $R_{SOURCE}=37.5\Omega$, $R_L=150\Omega$ loads; all inputs are AC couple with $0.1\mu\text{F}$; all outputs are AC coupled with $220\mu\text{F}$; unless otherwise specified.

| Symbol | Parameter | Conditions | Min. | Typ. | Max. | Unit |
|---|---------------------------------|---|------|------|------|------------------|
| DC ELECTRICAL CHARACTERISTICS | | | | | | |
| I_{CC} | Supply Current | HD + SD Channels | | 78 | 90 | mA |
| V_{IN} | Input Common Mode Voltage Range | | GND | | 1.4 | V _{pp} |
| PSRR | Power Supply Rejection | | | -60 | -50 | dB |
| HIGH DEFINITION AC PERFORMANCE | | | | | | |
| AV | Channel Gain | | 5.8 | 6.0 | 6.2 | dB |
| BW | Band Width | $\pm 0.5\text{dB}$, $R_{SOURCE}=75\Omega$ | | 26 | | MHz |
| | | -1dB, $R_{SOURCE}=75\Omega$ | | 31 | | |
| | | -3dB, $R_{SOURCE}=75\Omega$ | | 37 | | |
| AR | Attenuation | $f=74.25\text{MHz}$, $R_{SOURCE}=75\Omega$ | | -33 | | dB |
| THD | Output Distortion | $V_{OUT}=1.4\text{V}_{PP}$, $f=10\text{MHz}$ | | 0.6 | | % |
| | | $V_{OUT}=1.4\text{V}_{PP}$, $f=20\text{MHz}$ | | 0.8 | | |
| X_{TALK} | Crosstalk | $f=1\text{MHz}$, $V_{IN}=1.4\text{V}_{PP}$ | | -75 | | dB |
| SNR | Signal to Noise Ratio | 100kHz to 30MHz, 100% White Signal | | 65 | | dB |
| | Group Delay | 100kHz to 30MHz | | 5 | | ns |
| | Propagation Delay | Input to Output | | 20 | | ns |
| SR | Slew Rate | 2V Output 80% to 20% | | 90 | | V/ μs |
| STANDARD DEFINITION AC PERFORMANCE | | | | | | |
| AV | Channel Gain | | 5.8 | 6.0 | 6.2 | dB |
| BW | Bandwidth | -1dB | | 8.0 | | MHz |
| | | -3dB | | 9.0 | | |
| AR | Attenuation | $f=27\text{MHz}$ | | -56 | | dB |
| DG | Differential Gain | | | 0.6 | | % |
| DP | Differential Phase | | | 1.2 | | $^\circ$ |
| THD | Output Distortion | $f=4\text{MHz}$ | | 1.5 | | % |
| X_{TALK} | Crosstalk | $f=1\text{MHz}$ | | -85 | | dB |
| SNR | Signal to Noise Ratio | | | 70 | | dB |
| t_{PD} | Propagation Delay | | | 80 | | ns |
| | Group Delay | $f=400\text{kHz}$, 6.5MHz | | 10 | | ns |
| CLG_SD | Chroma Luma Gain | $f=3.58\text{MHz}$ ref to SD in at 400kHz | | 100 | | % |
| CLD_SD | Chroma Luma Delay | $f=3.58\text{MHz}$ ref to SD in at 400kHz | | 5.5 | | ns |

Notes: $\text{SNR}=20 \cdot \log(714\text{mV} / \text{rms noise})$.

Specifications subject to change without notice.



DIO2624

Typical Performance Characteristics for the Audio Driver

At $V_{DD}=3.3V$, $R_L=10k\Omega$, $C_{PUMP}=C_{PVSS}=1\mu F$, $R_{IN}=15k\Omega$, $R_{fb}=30k\Omega$, $T_A = +25^\circ C$, unless otherwise noted.

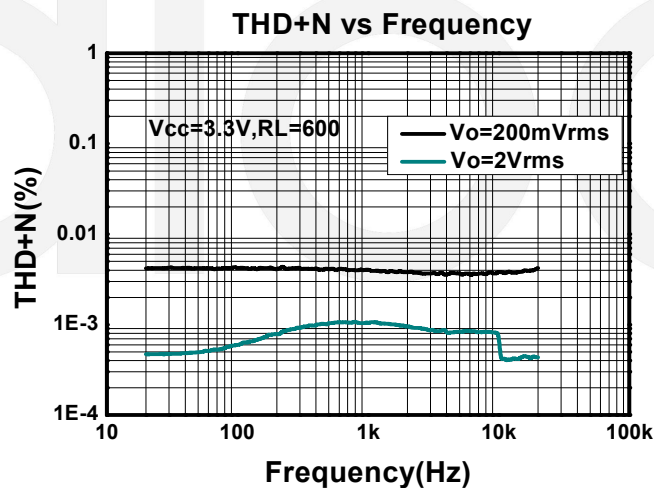
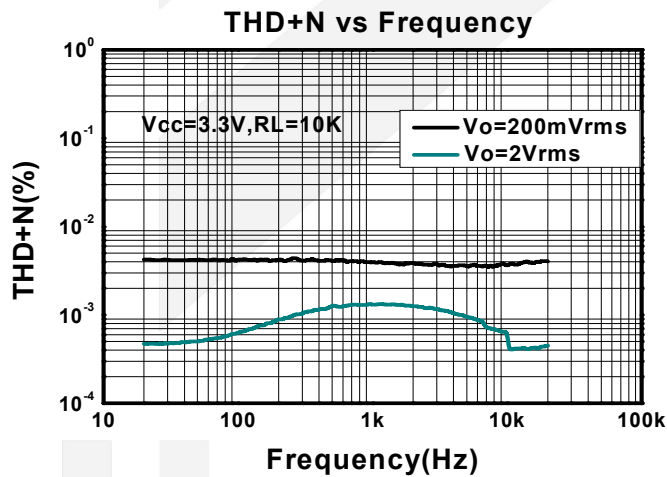
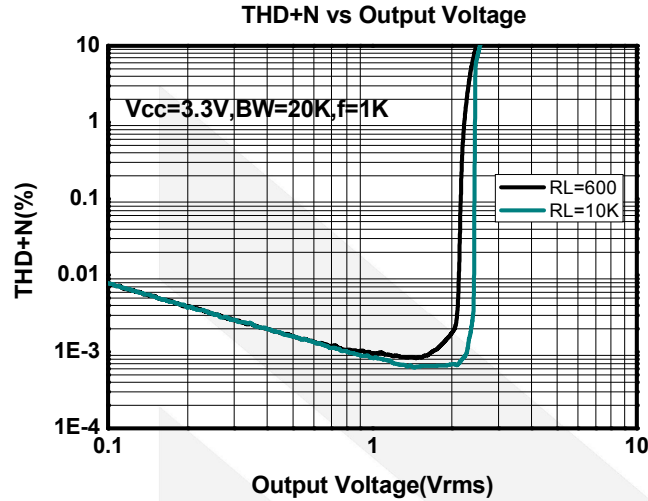

Typical Application

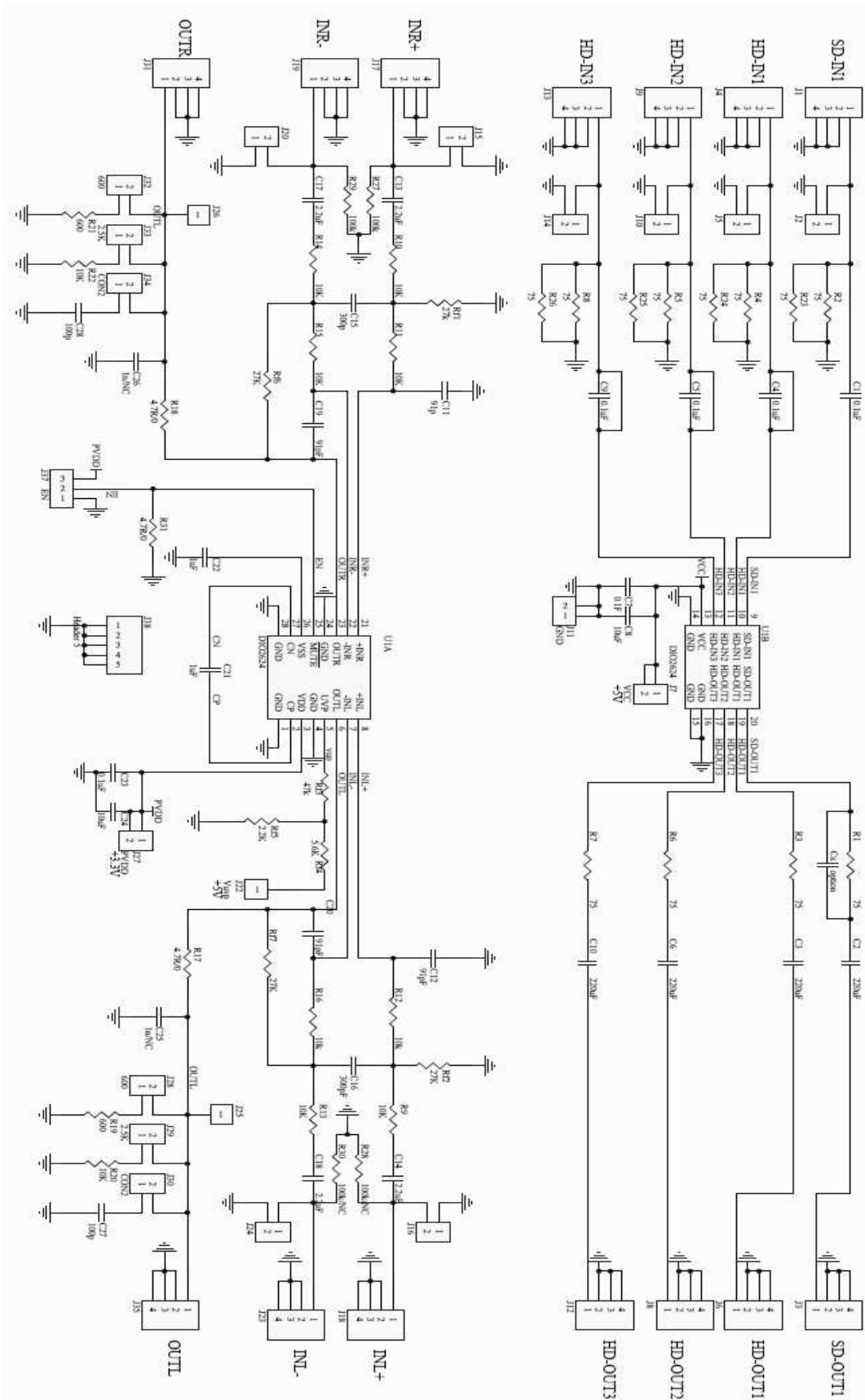

Application Notes

Important Note:

In some applications, if the power supply noise needs to be filtered, the ferrite bead is recommended in a value of 600Ω@100MHz, instead of RC network. RC network normally will lower the power supply resulting in the degraded the audio performance. If the resistor is not chosen properly, which can trigger the internal UVP detection circuit and mute the output. As depicted below.



Gain-Setting Resistors Ranges and Input-Blocking Capacitors

The gain-setting resistors, R_{IN} and R_{FB} , must be chosen so that noise, stability, and input capacitor size of the Audio Driver are kept within acceptable limits. Voltage gain is defined as R_{FB} divided by R_{IN} .

Table 1 lists the recommended resistor value for different gain settings. Selecting values that are too low demands a large input ac-coupling capacitor C_{IN} . Selecting values that are too high increases the noise of the amplifier.

The gain-setting resistor must be placed close to the input pins to minimize capacitive loading on these input pins and to ensure maximum stability.

Table 1 Input Capacitor with 2Hz cutoff and Resistor Values Recommended

| Input Res., R_{IN} | Feedback Res., R_{fb} | Inverting Gain |
|-------------------------|----------------------------|----------------|
| 22 kΩ | 22 kΩ | -1 V/V |
| 15 kΩ | 30 kΩ | -2 V/V |
| 10 kΩ | 100 kΩ | -10 V/V |

$$f_{CIN} = \frac{1}{2\pi R_{IN} C_{IN}}, \text{ or}$$

$$C_{IN} = \frac{1}{2\pi R_{IN} f_{CIN}}$$

Equation 1 Cutoff decision Cutoff

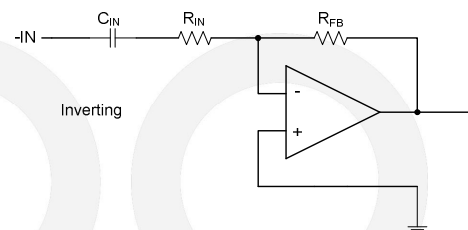

Figure 2 Inverting Gain Configuration

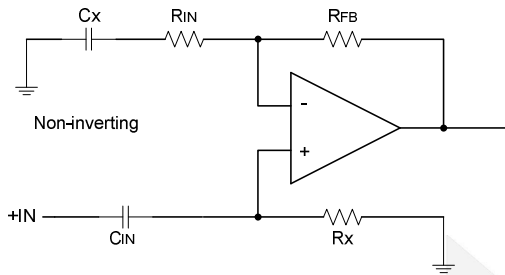

Figure 3 Non-Inverting Gain Configuration

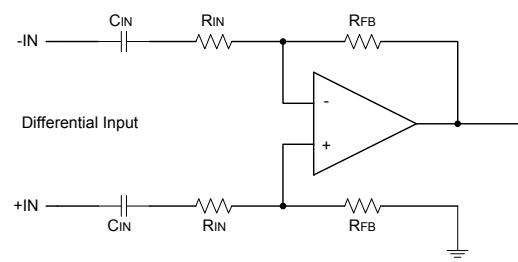

Figure 4 Differential Gain Configuration

INPUT-BLOCKING CAPACITORS

DC input-blocking capacitors are required to be added in series with the audio signal into the input pins of the Audio Driver. These capacitors block the dc portion of the audio source and allow the Audio Driver inputs to be properly biased to provide maximum performance.

2nd Order Filter Typical Application

Several audio DACs used today require an external low-pass filter to remove out-of-band noise. This is possible with the Audio Driver, as it can be used like a standard OPAMP. Several filter topologies can be implemented, both single-ended and differential. In Figure 5, a multi-feedback (MFB) with differential input and single-ended input is shown.

An ac-coupling capacitor to remove dc content from the source is shown; it serves to block any dc content from the source and lowers the dc-gain to 1, helping reducing the output dc-offset to minimum.

The resistor values should have a low value for obtaining low noise, but should also have a high enough value to get a small size ac-coupling capacitor.

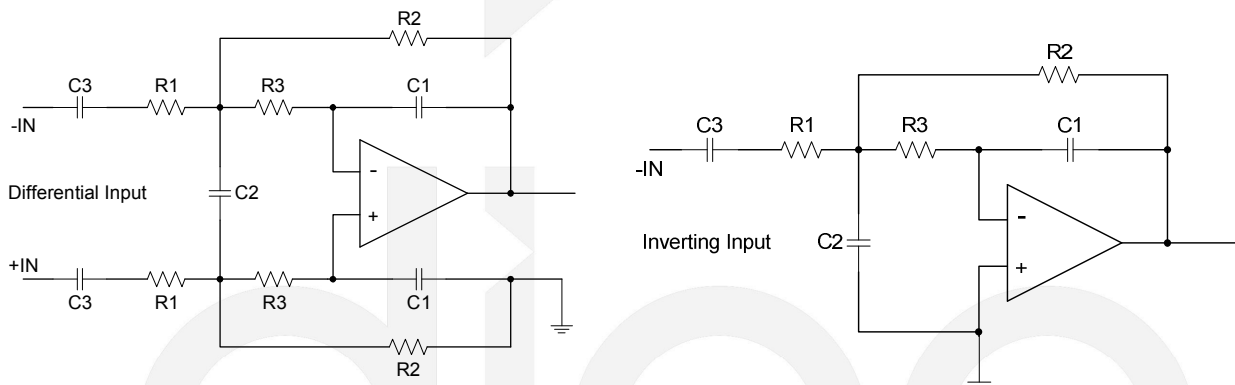

Figure 5 Second-Order Active Low-Pass Filter

Charge Pump Flying Capacitor and VSS Capacitor

The charge pump flying capacitor serves to transfer charge during the generation of the negative supply voltage. The VSS capacitor must be at least equal to the charge pump capacitor in order to allow maximum charge transfer. Low-ESR capacitors are an ideal selection, and a value of 1 μ F is typical. Capacitor values that are smaller than 1 μ F can be used, but the maximum output voltage may be reduced and the device may not operate to specifications.

Decoupling Capacitors

The Audio Driver requires adequate power supply decoupling to ensure that the noise and total harmonic distortion (THD) are low. A good low equivalent-series-resistance (ESR) ceramic capacitor, typically 1μF, placed as close as possible to the device VDD lead works best. Placing this decoupling capacitor close to the Audio Driver is important for the performance of the amplifier. For filtering lower-frequency noise signals, a 10μF or greater capacitor placed near the audio power amplifier would also help, but it is not required in most applications because of the high PSRR of this device.

Pop-Free Power-Up

Pop-free power up is ensured by keeping the $\overline{\text{Mute}}$ (shutdown pin) low during power-supply ramp up and ramp down. The $\overline{\text{Mute}}$ pin should be kept low until the input ac-coupling capacitors are fully charged before asserting the Mute pin high to achieve pop-less power up. Figure 6 illustrates the preferred sequence.

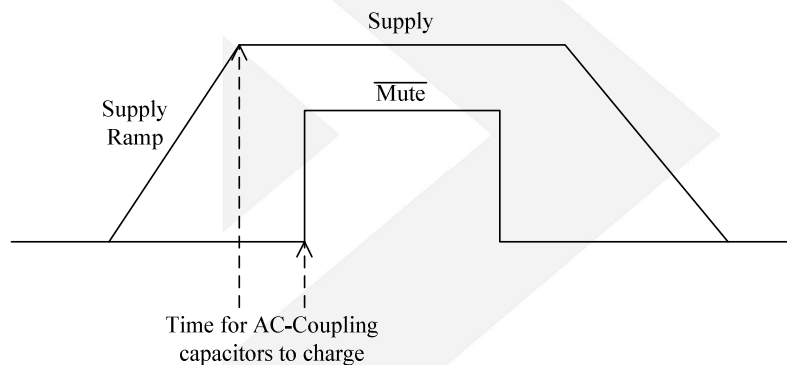

Figure 6 Power-Up Sequences

External Under-voltage Detection

External under-voltage detection can be used to mute/shut down the DIO2624 before an input device can generate a pop. Although the shutdown voltage is 1.25V typically, customers need to consider the accuracy of system passive components such as resistors and associated temperature variation. In order to guarantee the power-on of the device, usually greater than 1.325V at UVP pin is recommended to cover the possible uncertainty. Users often select a resistor divider to obtain the power-on and shutdown threshold for the specific application. The typical thresholds can be calculated as follows, respectively for VSUP_MO at 5V and 12V. Usually for best power down noise performance, 12V supply is recommended for UVP circuitry as below. Typically this 12V is the power supply which generates the 5V supply for DIO2624 VDD pins.

Case 1: VSUP_MO= 12V (**Recommended**)

$$V_{\text{UVP}} = (1.25\text{V} - 6\mu\text{A} \cdot R_{13}) \cdot (R_{11} + R_{12}) / R_{12};$$

$$V_{\text{hysteresis}} = 5\mu\text{A} \cdot R_{13} \cdot (R_{11} + R_{12}) / R_{12};$$

With the condition $R_{13} \gg R_{11} // R_{12}$.

For example, if $R_{11} = 11\text{k}$, $R_{12} = 1.4\text{k}$ and $R_{13} = 47\text{k}$,

Then $V_{\text{UVP}} = 8.574\text{V}$; $V_{\text{hysteresis}} = 2.081\text{V}$

Here, V_{UVP} is the shutdown threshold.

In this case, the voltage at UVP pin is greater than 1.325V under worst case of VSUP_MO ripples.

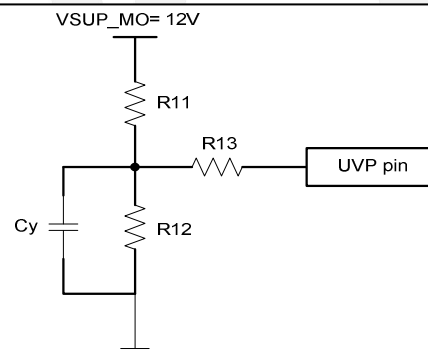

Case 2: VSUP_MO= 5.0V

$$V_{UVP} = (1.25V - 6\mu A * R_{13}) * (R_{11} + R_{12}) / R_{12};$$

$$V_{hysteresis} = 5\mu A * R_{13} * (R_{11} + R_{12}) / R_{12};$$

With the condition $R_{13} \gg R_{11} // R_{12}$.

For example, if $R_{11} = 5.6k$, $R_{12} = 2.43k$ and $R_{13} = 15k$,

Then $V_{UVP} = 3.83V$; $V_{hysteresis} = 0.247V$

Here, V_{UVP} is the shutdown threshold.

In this case, the voltage at UVP pin is greater than 1.325V under worst case of VSUP_MO ripples.

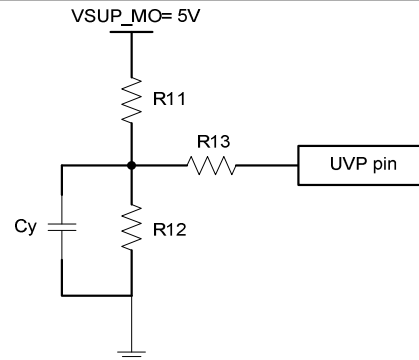

To minimize the system power-up and power-down threshold variations, resistors with less than 1% variations are recommended. Although some resistor value options are offered above for customer's reference or starting points, customers should always verify those resistor options in their actual design. Customer can adjust their own design to achieving the best performance between pop noise and power-on threshold by adjusting the passive resistors R11, R12 and R13.

Capacitive Load

The Audio Driver has the ability to drive a high capacitive load up to 220pF directly. Higher capacitive loads can be accepted by adding a series resistor of 47Ω or larger.

For further assistance, please contact DIOO worldwide sales office to seek technical support. You can find DIOO sales office information at www.dioo.com.



Physical Dimensions: EP-TSSOP-28

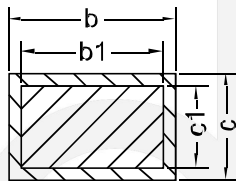
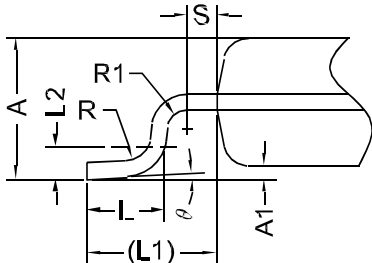
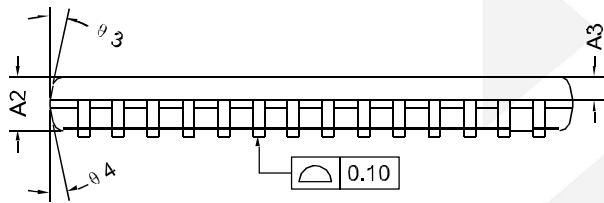
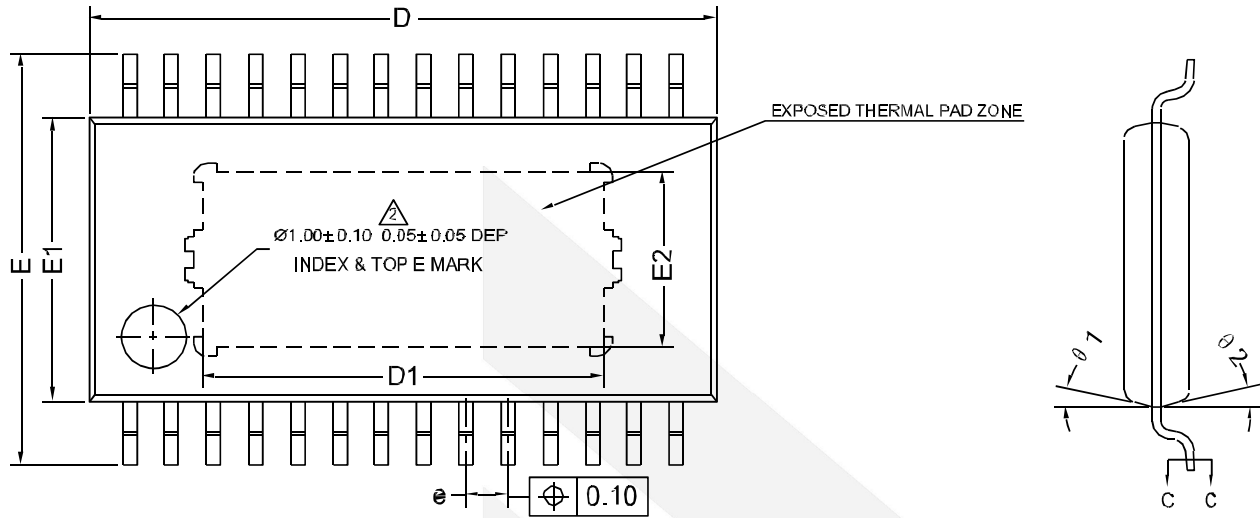

SECTION C-C
NORMAL PLATING

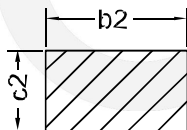

SECTION C-C
NIPDAU PLATING

| COMMON DIMENSIONS (UNITS OF MEASURE=MILLIMETER) | | | |
|--|---------|------|------|
| Symbol | MIN | NOM | MAX |
| A | - | - | 1.20 |
| A1 | 0.05 | - | 0.15 |
| A2 | 0.90 | 1.00 | 1.10 |
| A3 | 0.34 | 0.44 | 0.54 |
| b | 0.20 | - | 0.29 |
| b1 | 0.19 | 0.22 | 0.25 |
| b2 | 0.19 | - | 0.25 |
| c | 0.13 | - | 0.18 |
| c1 | 0.12 | 0.13 | 0.14 |
| C2 | 0.12 | - | 0.14 |
| D | 9.60 | 9.70 | 9.80 |
| D1 | 6.20REF | | |
| E | 6.20 | 6.40 | 6.60 |
| E1 | 4.30 | 4.40 | 4.50 |
| E2 | 2.75REF | | |
| e | 0.55 | 0.65 | 0.75 |
| L | 0.45 | 0.60 | 0.75 |
| L1 | 1.00REF | | |
| L2 | 0.25BSC | | |
| R | 0.09 | - | - |
| R1 | 0.09 | - | - |
| S | 0.20 | - | - |
| theta | 0° | - | 8° |
| theta1 | 10° | 12° | 14° |
| theta2 | 10° | 12° | 14° |
| theta3 | 10° | 12° | 14° |
| theta4 | 10° | 12° | 14° |



DIO2624

2-Vrms Audio Driver with Integrated 4-ch 6th-Order SD/HD Video Filter

Physical Dimensions: TSSOP-24

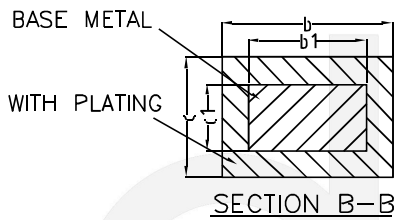
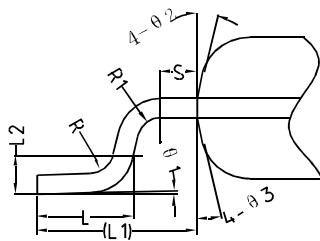
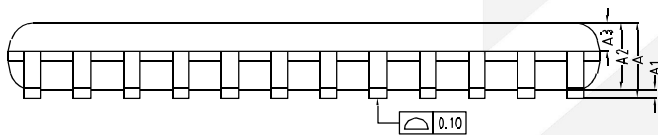
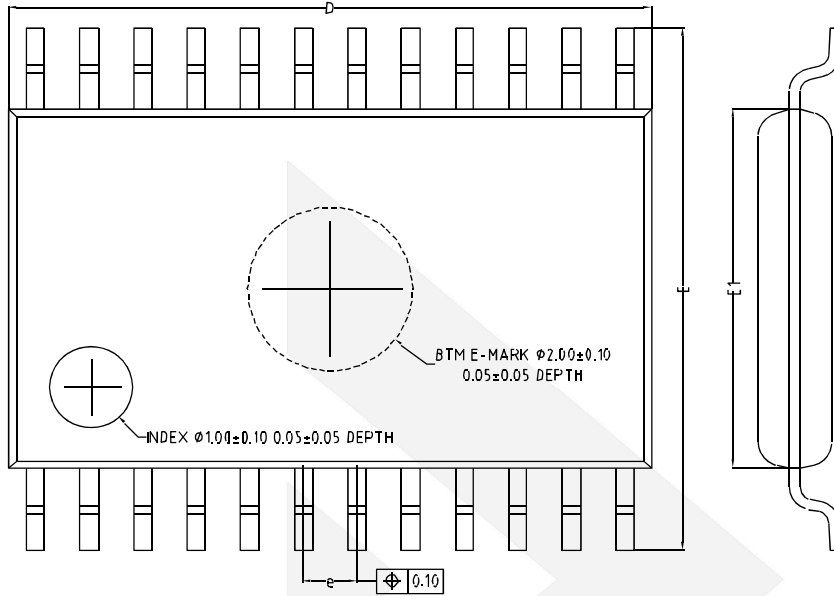

| COMMON DIMENSIONS (UNITS OF MEASURE=MILLIMETER) | | | |
|--|---------|------|------|
| Symbol | MIN | NOM | MAX |
| A | - | - | 1.20 |
| A1 | 0.05 | - | 0.15 |
| A2 | 0.80 | 0.90 | 1.00 |
| A3 | 0.34 | 0.39 | 0.44 |
| b | 0.20 | - | 0.29 |
| b1 | 0.19 | 0.22 | 0.25 |
| c | 0.10 | - | 0.19 |
| c1 | 0.10 | 0.13 | 0.15 |
| D | 7.70 | 7.80 | 7.90 |
| E | 6.20 | 6.40 | 6.60 |
| E1 | 4.30 | 4.40 | 4.50 |
| e | 0.55 | 0.65 | 0.75 |
| L | 0.45 | 0.60 | 0.75 |
| L1 | 1.00REF | | |
| L2 | 0.25BSC | | |
| R | 0.09 | - | - |
| R1 | 0.09 | - | - |
| S | 0.20 | - | - |
| Ø1 | 0° | - | 8° |
| Ø2 | 12° | 14° | 16° |
| Ø3 | 12° | 14° | 16° |



DIO2624

2-Vrms Audio Driver with Integrated 4-ch 6th-Order SD/HD Video Filter

CONTACT US

Dioo is a professional design and sales corporation for high-quality and performance analog semiconductors. The company focuses on industry markets, such as, cell phone, handheld products, laptop, and medical equipment and so on. Dioo's product families include analog signal processing and amplifying, LED drivers and charger IC. Go to <http://www.dioo.com> for a complete list of Dioo product families.

For additional product information, or full datasheet, please contact with our Sales Department or Representatives.

dioo



Компания «ЭлектроПласт» предлагает заключение долгосрочных отношений при поставках импортных электронных компонентов на взаимовыгодных условиях!

Наши преимущества:

- Оперативные поставки широкого спектра электронных компонентов отечественного и импортного производства напрямую от производителей и с крупнейших мировых складов;
- Поставка более 17-ти миллионов наименований электронных компонентов;
- Поставка сложных, дефицитных, либо снятых с производства позиций;
- Оперативные сроки поставки под заказ (от 5 рабочих дней);
- Экспресс доставка в любую точку России;
- Техническая поддержка проекта, помощь в подборе аналогов, поставка прототипов;
- Система менеджмента качества сертифицирована по Международному стандарту ISO 9001;
- Лицензия ФСБ на осуществление работ с использованием сведений, составляющих государственную тайну;
- Поставка специализированных компонентов (Xilinx, Altera, Analog Devices, Intersil, Interpoint, Microsemi, Aeroflex, Peregrine, Syfer, Eurofarad, Texas Instrument, Miteq, Cobham, E2V, MA-COM, Hittite, Mini-Circuits, General Dynamics и др.);

Помимо этого, одним из направлений компании «ЭлектроПласт» является направление «Источники питания». Мы предлагаем Вам помощь Конструкторского отдела:

- Подбор оптимального решения, техническое обоснование при выборе компонента;
- Подбор аналогов;
- Консультации по применению компонента;
- Поставка образцов и прототипов;
- Техническая поддержка проекта;
- Защита от снятия компонента с производства.



Как с нами связаться

Телефон: 8 (812) 309 58 32 (многоканальный)

Факс: 8 (812) 320-02-42

Электронная почта: org@eplast1.ru

Адрес: 198099, г. Санкт-Петербург, ул. Калинина, дом 2, корпус 4, литера А.