

10 9 8 7 6 5 4 3 2 1

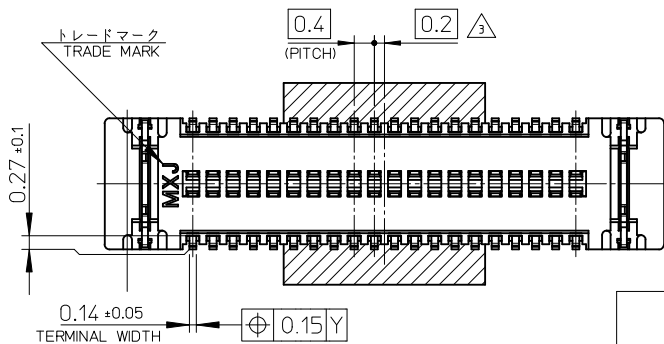
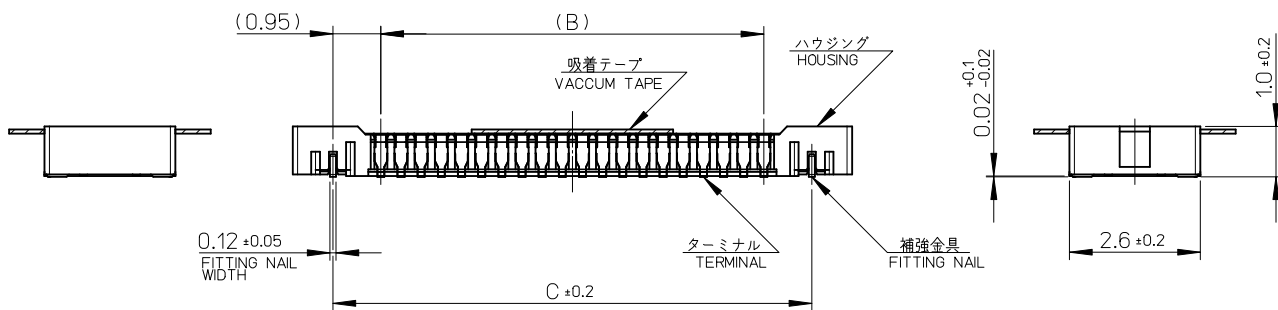
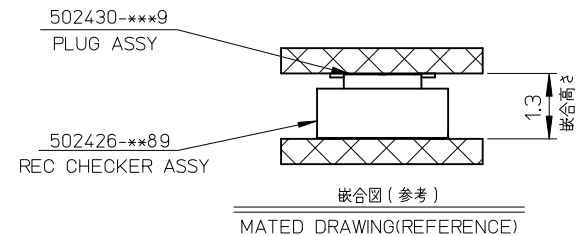
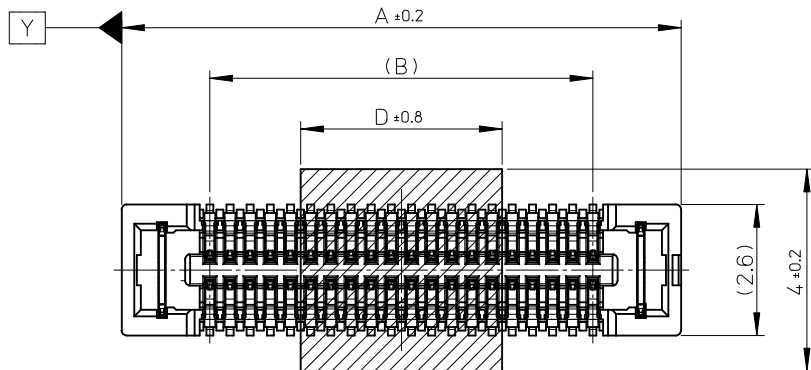

10.0	17.5	15.6	19.1	502426-8080	502426-8089	80
7.0	13.5	11.6	15.1	502426-6080	502426-6089	60
	11.5	9.6	13.1	502426-5080	502426-5089	50
4.0	9.5	7.6	11.1	502426-4080	502426-4089	40
	7.9	6.0	9.5	502426-3280	502426-3289	32
3.4	6.7	4.8	8.3	502426-2680	502426-2689	26
	6.3	4.4	7.9	502426-2480	502426-2489	24
	5.9	4.0	7.5	502426-2280	502426-2289	22
2.4	5.5	3.6	7.1	502426-2080	502426-2089	20
	4.3	2.4	5.9	502426-1480	502426-1489	14
D	C	B	A	EMBOSSED TAPE	MATERIAL No.	CKT.
				ORDER No.	MODEL No. : 502426-***x	

<b>REVISED</b> EC NO: J2011-1598 DRWN:KTOYODA 2011/05/23 CHKD:TASAKAWA 2011/05/25 APPR:MSASAO 2011/06/16	GENERAL TOLERANCES (UNLESS SPECIFIED)	DIMENSION STYLE <b>MM ONLY</b>	SCALE <b>10:1</b>	DESIGN UNITS <b>METRIC</b>	THIRD ANGLE PROJECTION	
	10 UNDER ± --- 10 OVER 30 UNDER ± --- 30 OVER ± ---	DRAWN BY RTAKEUCHI	DATE 2007/12/26	TITLE <b>0.4 B-TO-B CONN. HGT=1.0                  W=2.6 REC CHECKER ASSY                  WITH TAPE</b>		
	ANGULAR ± --- ° DRAFT WHERE APPLICABLE MUST REMAIN WITHIN DIMENSIONS	CHECKED BY MSASAO	DATE 2007/12/26	MOLEX INCORPORATED		
		APPROVED BY MSASAO	DATE 2007/12/26	DOCUMENT NO. SD-502426-007	SHEET NO. 1 OF 2	

注記 NOTES

1. 使用材料 MATERIAL

ハウジング：液晶ポリマー ( LCP ) ガラス充填 UL94V-0 ( 黒 )  
HOUSING: LIQUID CRYSTAL POLYMER (GLASS FILLED) UL94V-0 ( COLOR: BLACK )

ターミナル：りん青銅 (t=0.1)  
TERMINAL : PHOSPHOR BRONZE (t=0.1)

金具：りん青銅 (t=0.12)  
FITTING NAIL : PHOSPHOR BRONZE (t=0.12)

吸着テープ：ポリイミド  
VACUUM TAPE : POLYIMIDE

2. メッキ仕様 PLATING

ターミナル TERMINAL

コンタクト部：金メッキ 0.1 マイクロメートル以上  
CONTACT AREA : GOLD 0.1 MICROMETER MINIMUM.

テール部：金メッキ 0.05 マイクロメートル以上  
TAIL AREA : GOLD 0.05 MICROMETER MINIMUM.

下地メッキ：ニッケルメッキ 1.0 マイクロメートル以上  
UNDER PLATING : NICKEL 1.0 MICROMETER MINIMUM

※コンタクト部とテール部はニッケルメッキによって分断されている金メッキです。  
DIVIDE INTO PARTS THE GOLD PLATING OF THE CONTACT AND THE TAIL PART BY THE NICKEL PLATING.

※封孔処理品

金具 FITTING NAIL

フラッシュ金メッキ  
FLASH Au PLATING

下地メッキ：ニッケルメッキ 1.0 マイクロメートル以上  
UNDER PLATING : NICKEL 1.0 MICROMETER MINIMUM

△3 (全極数 / 2) = 偶数の場合に適用。  
APPLY FOR (CIRCUIT / 2) = EVEN.

4. 嵌合相手： 502430 シリーズ  
MATE WITH : 502430 SERIES.

5. テール平坦度は、0.08 以下

テール及び金具の平坦度は、0.1 以下

TAIL COPLANARITY TO BE 0.08 MAXIMUM.

TAIL AND FITTING NAIL COPLANARITY TO BE 0.1 MAXIMUM.

6. ELV 及び RoHS 適合品

ELV AND RoHS COMPLIANT.

△7 斜線部はパターン書込み禁止範囲と半田禁止範囲を示す。

ただし、斜線部に補強金具と同一配線を配置する場合はレジストを施し、この部分に半田は無きこと。  
NO PATTERN CIRCUIT AND NO SOLDER ALLOWED IN THE SHADED AREA.  
HOWEVER, IF NEEDED TO ADD A TRACE OF THE SAME CIRCUIT, PUT THE SOLDER-RESIST, YET NO SOLDER ALLOWED IN THE AREA.

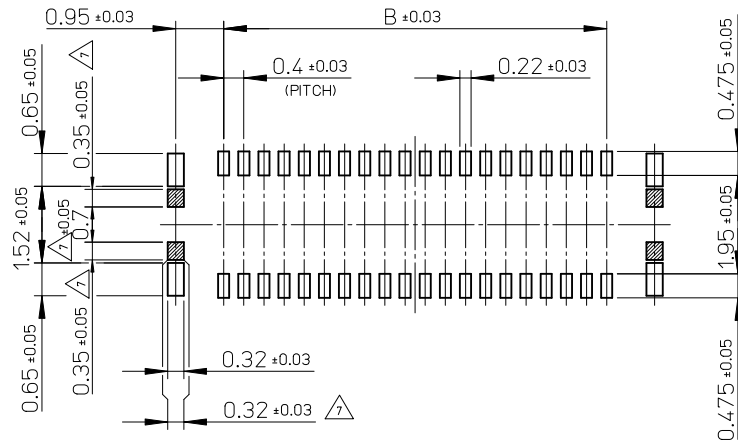

P.C. BOARD PATTERN LAYOUT  
(REFERENCE)

REVISED EC NO: J2011-1598 DRW: KTOYODA 2011/05/23 CHKD: TASAKAWA 2011/05/25 APPR: MSASAO 2011/06/16	GENERAL TOLERANCES (UNLESS SPECIFIED)		DIMENSION STYLE MM ONLY	SCALE 10:1	DESIGN UNITS METRIC	THIRD ANGLE PROJECTION
	10 UNDER	± ---	DRAWN BY RTAKEUCHI	DATE 2007/12/26	TITLE 0.4 B-TO-B CONN. HGT=1.0 W=2.6 REC CHECKER ASSY WITH TAPE	
	10 OVER 30 UNDER	± ---	CHECKED BY MSASAO	DATE 2007/12/26	MOLEX INCORPORATED	
	30 OVER	± ---	APPROVED BY MSASAO	DATE 2007/12/26		
ANGULAR	± --- °	MATERIAL NO. SEE SHEET 1	DOCUMENT NO. SD-502426-007	SHEET NO. 2 OF 2		
	DRAFT WHERE APPLICABLE MUST REMAIN WITHIN DIMENSIONS	THIS DRAWING CONTAINS INFORMATION THAT IS PROPRIETARY TO MOLEX INCORPORATED AND SHOULD NOT BE USED WITHOUT WRITTEN PERMISSION				

注記 NOTES

- 製品詳細寸法については製品単体図面を参照下さい。  
RE DETAILED DIMENSION, SEE PRODUCT DRAWING.
- 梱包数量：3000 個/リール  
NUMBER OF CONNECTORS : 3000PCS/REEL
- リードテープ長さ LEAD TAPE LENGTH

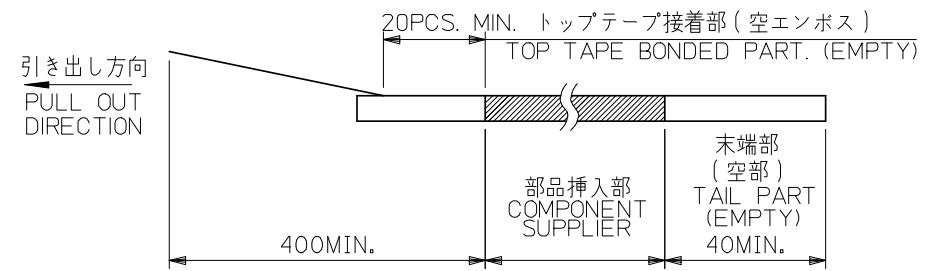
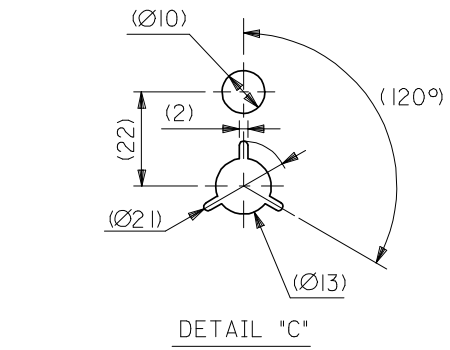
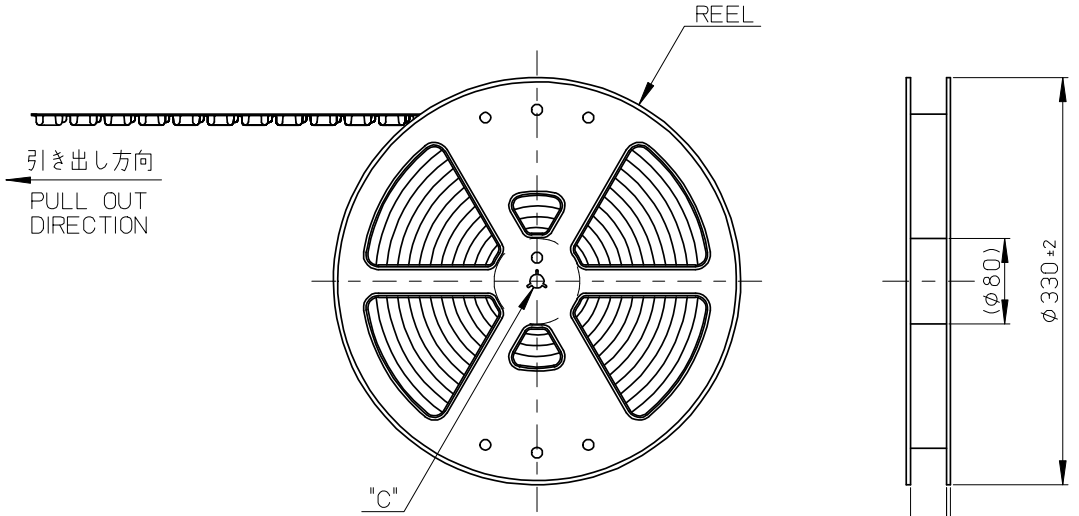

- トップテープの剝離強度：0.1N~1.3N(10gf~130gf)  
(剝離方向は下図参照)  
尚、本規格値は出荷時に適用。(但し、輸送時に剝離が発生しないこと。)  
PEELING OFF FORCE OF TOP TAPE : 0.1N~1.3N(10gf~130gf)  
(PEELING DIRECTION AS SHOWN IN FOLLOWING FIG.)  
THIS REQUIREMENT SHOULD BE APPLIED AT SHIPMENT.  
PEEL OFF SHOULD NOT BE ALLOWED , DURING TRANSPORTION.

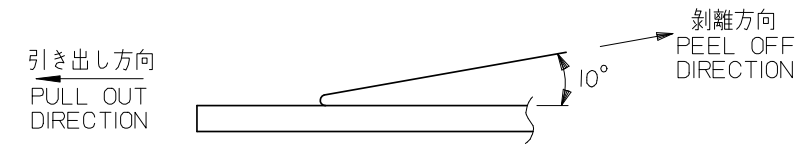

- 材料 MATERIAL  
キャリアテープ (CARRIER TAPE) : ポリスチレン (POLYSTYRENE)  
トップテープ (TOP TAPE) : PET , PE , PEF  
リール (REEL) : ポリスチレン (PS) <リサイクル材を含む>  
POLYSTYRENE (PS) <RECYCLE MATERIAL CONTAINED>
- ELV 及び RoHS適合品  
ELV AND RoHS COMPLIANT

MODEL NO. 502426-\*\*80

REVISED EC NO: J2009-0107 DRWN: ITANI GUCHI 101 2008/08/05 CHKD: MSASAO 2008/08/06 APPR: MSASAO 2008/08/08	DESCRIPTION REV	GENERAL TOLERANCES (UNLESS SPECIFIED)		DIMENSION STYLE MM ONLY		SCALE ---	DESIGN UNITS METRIC	THIRD ANGLE PROJECTION		
		10 UNDER	±---	DRAWN BY RTAKEUCHI	DATE 2007/12/26	TITLE 0.4 B-TO-B CONN. HGT=1.0 REC CHECKER ASSY WITH TAPE EMBSTP PKG				
		10 OVER 30 UNDER	±---	CHECKED BY MSASAO	DATE 2007/12/26	MOLEX INCORPORATED				
		30 OVER	±---	APPROVED BY MSASAO	DATE 2007/12/26	MATERIAL NO. SEE CHART		DOCUMENT NO. SD-502426-008	SHEET NO. 1 OF 4	
		ANGULAR	±---	DRAFT WHERE APPLICABLE MUST REMAIN WITHIN DIMENSIONS		THIS DRAWING CONTAINS INFORMATION THAT IS PROPRIETARY TO MOLEX INCORPORATED AND SHOULD NOT BE USED WITHOUT WRITTEN PERMISSION				

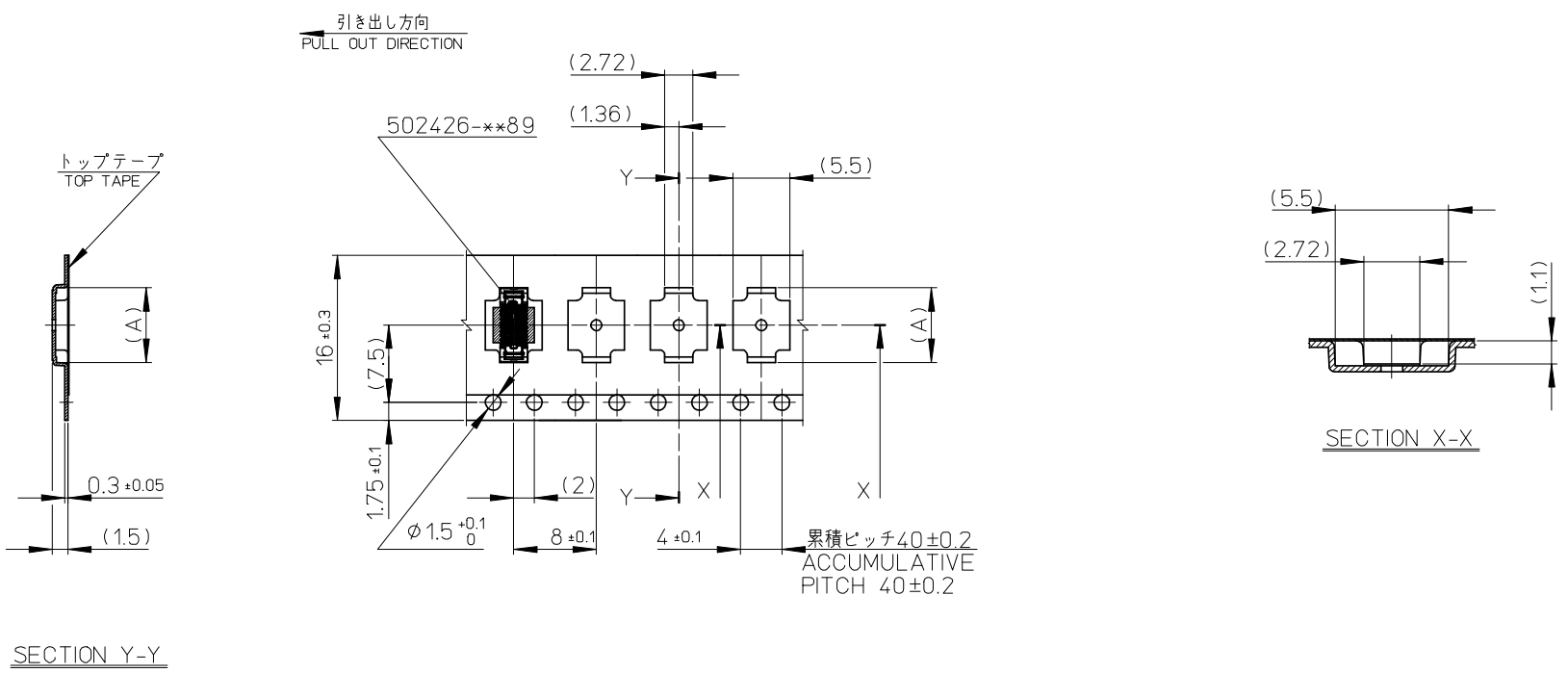

16mm 幅キャリアテープ  
16mm WIDTH CARRIER TAPE

16	17.5	8.42	502426-2680	26	
		8.02	502426-2480	24	
		7.62	502426-2280	22	
		7.22	502426-2080	20	
		6.02	502426-1480	14	
キャリアテープ幅 CARRIER TAPE WIDTH		B	(A)	MATERIAL No.	CKT.
			MODEL No.	502426-**80	

REVISED EC NO: J2009-0107 DRWN: ITANI GUCHI 01 2008/08/05 CHKD: MSASAO 2008/08/06 APPR: MSASAO 2008/08/08	DESCRIPTION	GENERAL TOLERANCES (UNLESS SPECIFIED)		DIMENSION STYLE MM ONLY		SCALE ---	DESIGN UNITS METRIC		THIRD ANGLE PROJECTION	
		10 UNDER	±---	DRAWN BY RTAKEUCHI	DATE 2007/12/26	TITLE 0.4 B-TO-B CONN. HGT=1.0 REC CHECKER ASSY WITH TAPE EMBSTP PKG				
		10 OVER 30 UNDER	±---	CHECKED BY MSASAO	DATE 2007/12/26					
		30 OVER	±---	APPROVED BY MSASAO	DATE 2007/12/26	MOLEX INCORPORATED				
		ANGULAR	±---	MATERIAL NO. SEE CHART		DOCUMENT NO. SD-502426-008		SHEET NO. 2 OF 4		
		DRAFT WHERE APPLICABLE MUST REMAIN WITHIN DIMENSIONS		SIZE A3		THIS DRAWING CONTAINS INFORMATION THAT IS PROPRIETARY TO MOLEX INCORPORATED AND SHOULD NOT BE USED WITHOUT WRITTEN PERMISSION				

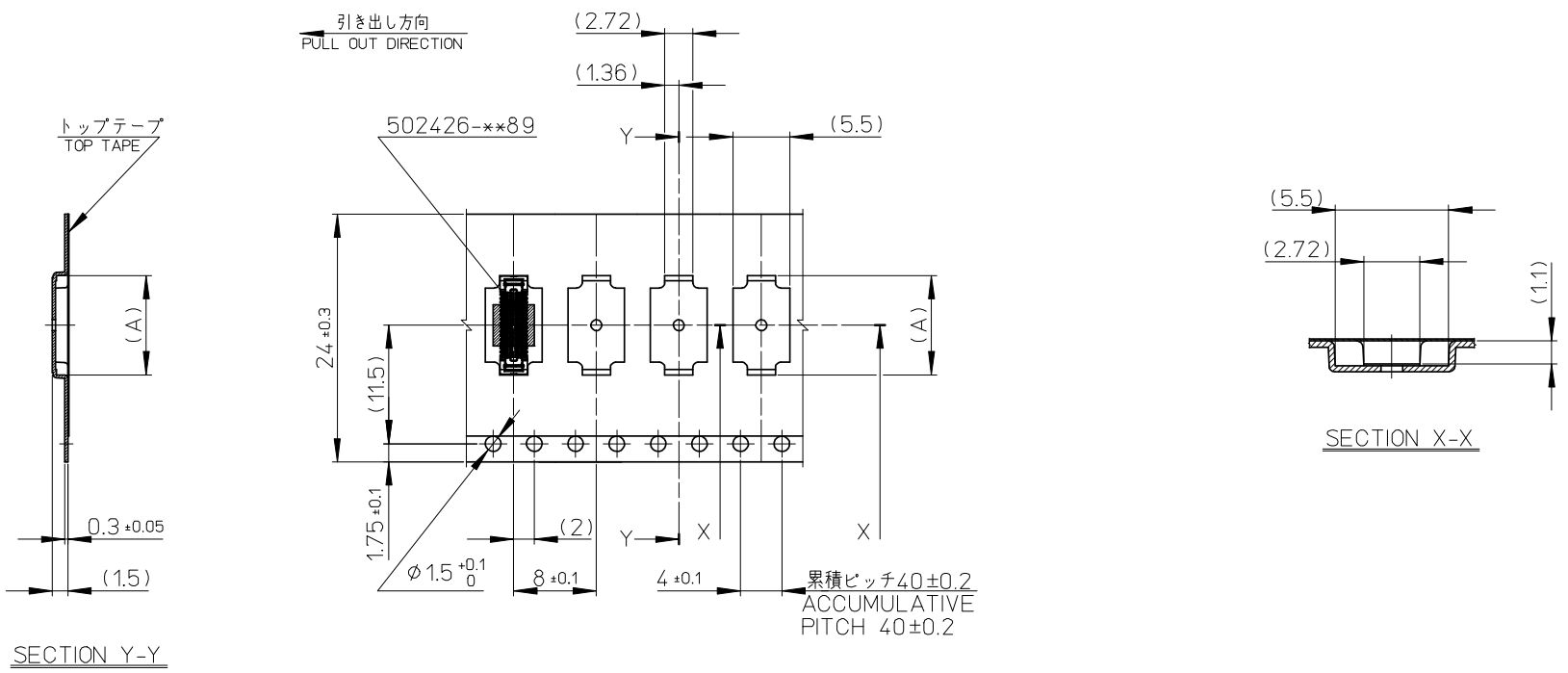

24mm 幅キャリアテープ  
24mm WIDTH CARRIER TAPE

24	25.5	15.22	502426-6080	60
		13.22	502426-5030	50
		11.22	502426-4080	40
		9.62	502426-3280	32
キャリアテープ幅 CARRIER TAPE WIDTH	B	(A)	MATERIAL No.	CKT.
			MODEL No.	502426-**80

REVISED EC NO: J2009-0107 DRWN: ITANI GUCHI 01 2008/08/05 CHK: MSASAO 2008/08/06 APPR: MSASAO 2008/08/08	DESCRIPTION	GENERAL TOLERANCES (UNLESS SPECIFIED)	DIMENSION STYLE MM ONLY	SCALE ---	DESIGN UNITS METRIC	THIRD ANGLE PROJECTION
	REV	10 UNDER ±---	DRAWN BY RTAKEUCHI	DATE 2007/12/26	TITLE 0.4 B-TO-B CONN. HGT=1.0 REC CHECKER ASSY WITH TAPE EMBSTP PKG	
		10 OVER 30 UNDER ±---	CHECKED BY MSASAO	DATE 2007/12/26	MOLEX INCORPORATED	
		30 OVER ±---	APPROVED BY MSASAO	DATE 2007/12/26	DOCUMENT NO. SD-502426-008	SHEET NO. 3 OF 4
		ANGULAR ±---	MATERIAL NO. SEE CHART		THIS DRAWING CONTAINS INFORMATION THAT IS PROPRIETARY TO MOLEX INCORPORATED AND SHOULD NOT BE USED WITHOUT WRITTEN PERMISSION	
		DRAFT WHERE APPLICABLE MUST REMAIN WITHIN DIMENSIONS				

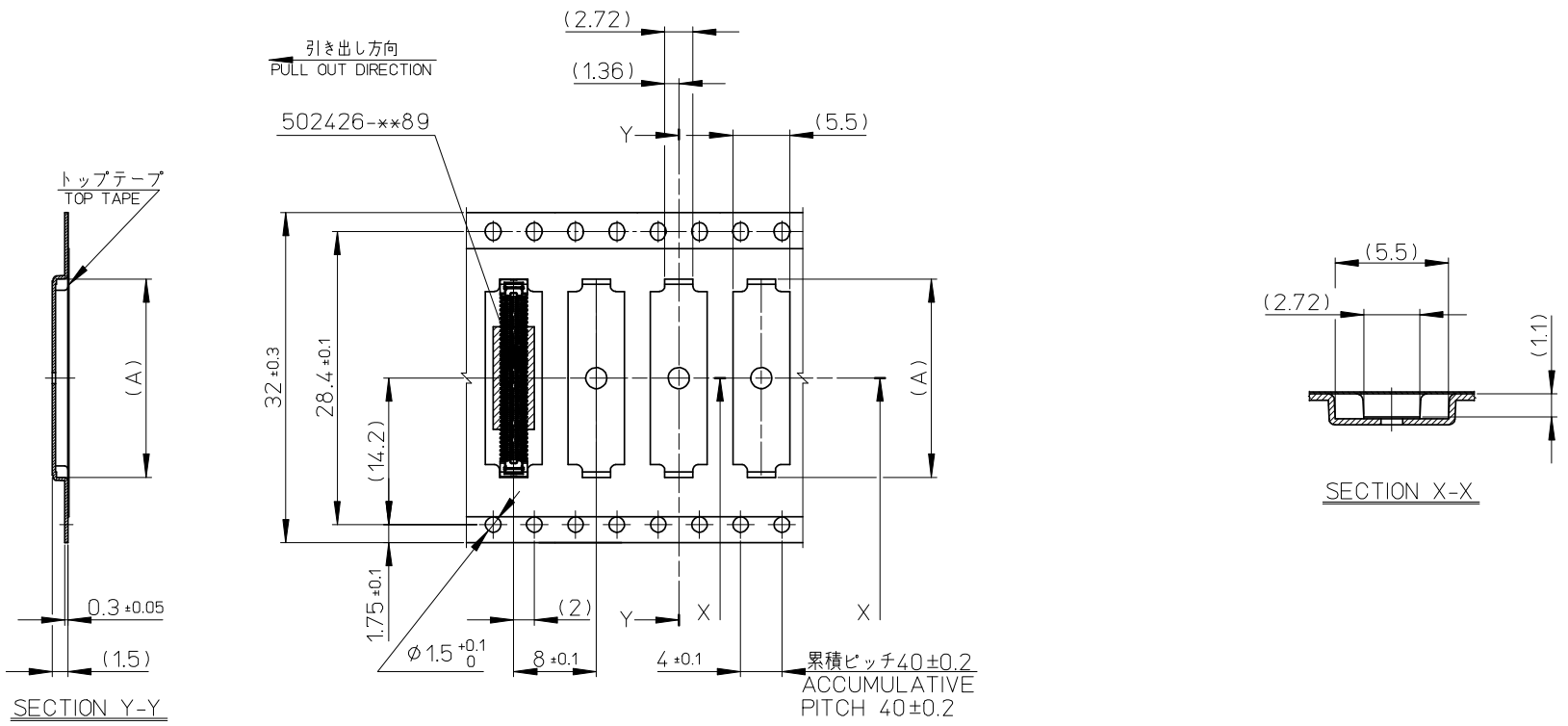

32mm 幅キャリアテープ  
32mm WIDTH CARRIER TAPE

32	33.5	21.22	502426-9080	90
		19.22	502426-8080	80
キャリアテープ幅 CARRIER TAPE WIDTH		B	(A)	MATERIAL No. CKT.
			MODEL No.	502426-**80

REVISED EC NO: J2009-0107 DRWN: ITANI GUCHI 01 2008/08/05 CHK: MSASAO 2008/08/06 APPR: MSASAO 2008/08/08	DESCRIPTION	GENERAL TOLERANCES (UNLESS SPECIFIED)	DIMENSION STYLE	SCALE	DESIGN UNITS	THIRD ANGLE PROJECTION	
	REV	10 UNDER ±---	MM ONLY	---	METRIC	☉ □	
		10 OVER 30 UNDER ±---		DRAWN BY DATE	TITLE		
		30 OVER ±---		RTAKEUCHI 2007/12/26	0.4 B-TO-B CONN. HGT=1.0 REC CHECKER ASSY WITH TAPE EMBSTP PKG		
		ANGULAR ±---		CHECKED BY DATE	MOLEX MOLEX INCORPORATED		
		DRAFT WHERE APPLICABLE MUST REMAIN WITHIN DIMENSIONS	APPROVED BY DATE	MATERIAL NO.	DOCUMENT NO.	SHEET NO.	
			MSASAO 2007/12/26	SEE CHART	SD-502426-008	4 OF 4	
				THIS DRAWING CONTAINS INFORMATION THAT IS PROPRIETARY TO MOLEX INCORPORATED AND SHOULD NOT BE USED WITHOUT WRITTEN PERMISSION			



Компания «ЭлектроПласт» предлагает заключение долгосрочных отношений при поставках импортных электронных компонентов на взаимовыгодных условиях!

Наши преимущества:

- Оперативные поставки широкого спектра электронных компонентов отечественного и импортного производства напрямую от производителей и с крупнейших мировых складов;
- Поставка более 17-ти миллионов наименований электронных компонентов;
- Поставка сложных, дефицитных, либо снятых с производства позиций;
- Оперативные сроки поставки под заказ (от 5 рабочих дней);
- Экспресс доставка в любую точку России;
- Техническая поддержка проекта, помощь в подборе аналогов, поставка прототипов;
- Система менеджмента качества сертифицирована по Международному стандарту ISO 9001;
- Лицензия ФСБ на осуществление работ с использованием сведений, составляющих государственную тайну;
- Поставка специализированных компонентов (Xilinx, Altera, Analog Devices, Intersil, Interpoint, Microsemi, Aeroflex, Peregrine, Syfer, Eurofarad, Texas Instrument, Miteq, Cobham, E2V, MA-COM, Hittite, Mini-Circuits, General Dynamics и др.);

Помимо этого, одним из направлений компании «ЭлектроПласт» является направление «Источники питания». Мы предлагаем Вам помощь Конструкторского отдела:

- Подбор оптимального решения, техническое обоснование при выборе компонента;
- Подбор аналогов;
- Консультации по применению компонента;
- Поставка образцов и прототипов;
- Техническая поддержка проекта;
- Защита от снятия компонента с производства.



#### Как с нами связаться

**Телефон:** 8 (812) 309 58 32 (многоканальный)

**Факс:** 8 (812) 320-02-42

**Электронная почта:** [org@eplast1.ru](mailto:org@eplast1.ru)

**Адрес:** 198099, г. Санкт-Петербург, ул. Калинина, дом 2, корпус 4, литера А.