

HDSP-521A/523A

14.22 mm (0.56 inch) Dual Digit General Purpose
Seven Segment Display

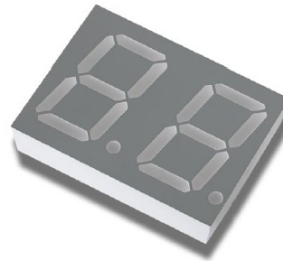

Data Sheet



Description

The 14.22 mm (0.56 inch) LED dual digit seven segment displays use industry standard size package and pinout. The device is available in either common anode or common cathode. These gray face displays are suitable for indoor use.

Devices

AlGaAs Red	Description
HDSP-521A	Common Anode Right Hand Decimal
HDSP-523A	Common Cathode Right Hand Decimal

Features

- Industry standard size
- Industry standard pinout
14.22 mm (0.56 inch)
DIP lead on 2.54 mm
- AlGaAs Red color
- Excellent appearance
Evenly lighted segments gray package gives optimum contrast \pm 50 ft. viewing angle
- Design flexibility
Common anode right hand decimal point or common cathode right hand decimal point

Applications

- Suitable for indoor use
- Not recommended for industrial application, i.e., operating temperature requirements exceeding +85°C or below -35°C^[1]
- Extreme temperature cycling not recommended

Note:

1. For additional details, please contact your local Avago sales office or an authorized distributor.

Part Numbering System

5082 - x xx x - x x x xx
HDSP - x xx x - x x x xx

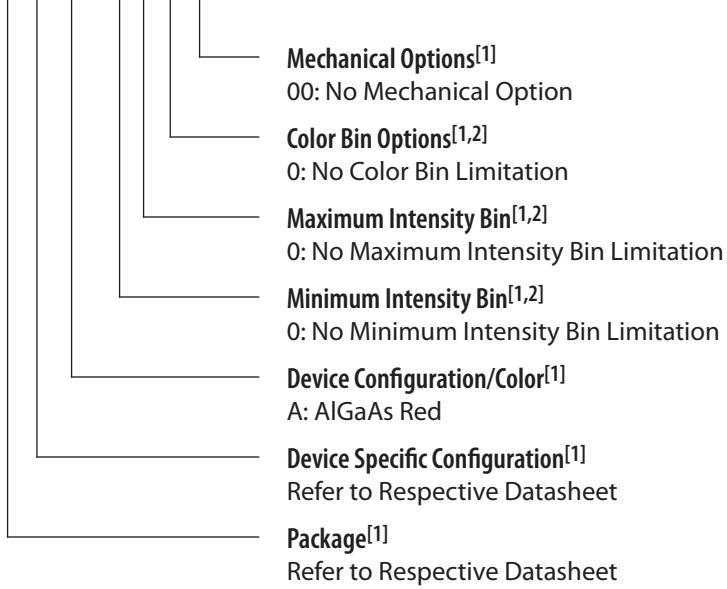

Notes:

1. For codes not listed in the figure above, please refer to the respective data sheet or contact your nearest Avago representative for details.
2. Bin options refer to shippable bins for a part number. Color and Intensity Bins are typically restricted to 1 bin per tube (exceptions may apply). Please refer to respective data sheet for specific bin limit information.

Package Dimensions

TOP END VIEW

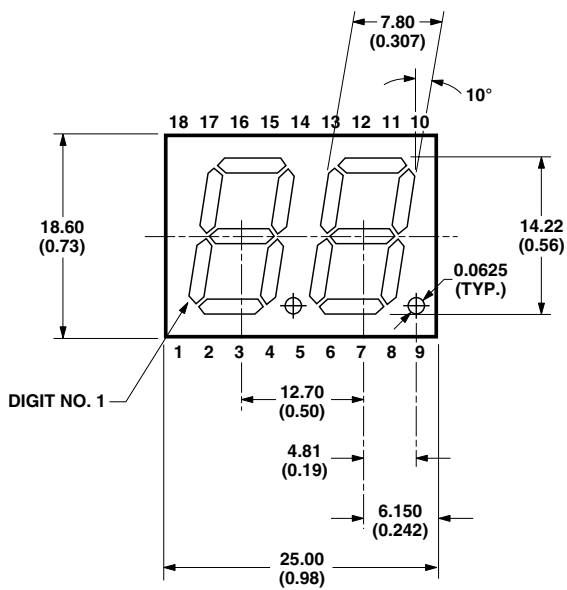
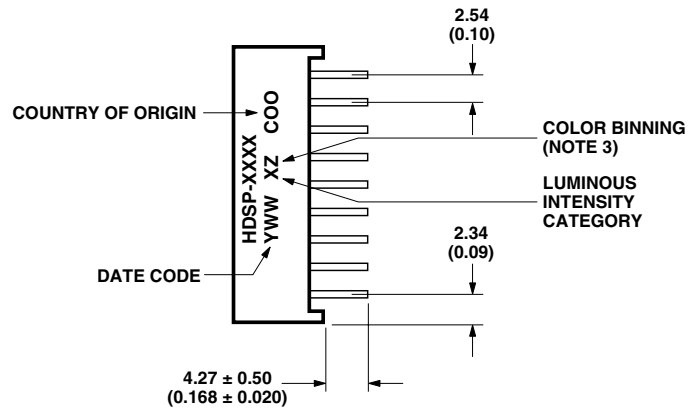

FRONT VIEW

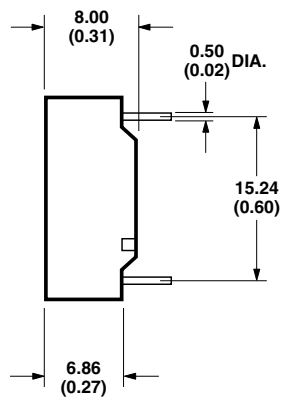

SIDE VIEW

ALL DIMENSIONS ARE IN MILLIMETERS (INCHES).

Internal Circuit Diagram

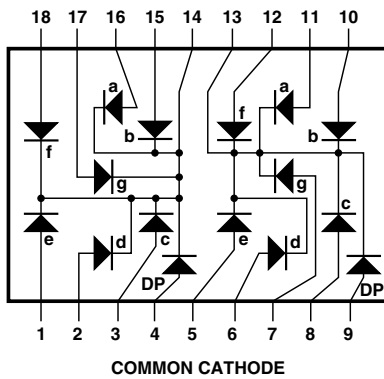
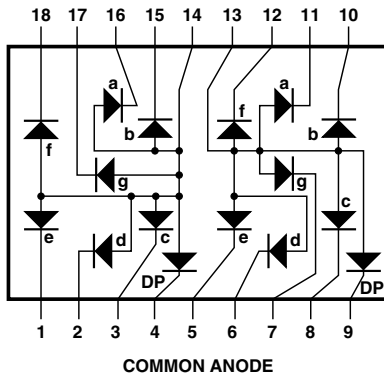

COMMON ANODE		COMMON CATHODE	
PIN	FUNCTION	PIN	FUNCTION
1	E CATHODE NO. 1	1	E ANODE NO. 1
2	D CATHODE NO. 1	2	D ANODE NO. 1
3	C CATHODE NO. 1	3	C ANODE NO. 1
4	DP CATHODE NO. 1	4	DP ANODE NO. 1
5	E CATHODE NO. 2	5	E ANODE NO. 2
6	D CATHODE NO. 2	6	D ANODE NO. 2
7	G CATHODE NO. 2	7	G ANODE NO. 2
8	C CATHODE NO. 2	8	C ANODE NO. 2
9	DP CATHODE NO. 2	9	DP ANODE NO. 2
10	B CATHODE NO. 2	10	B ANODE NO. 2
11	A CATHODE NO. 2	11	A ANODE NO. 2
12	F CATHODE NO. 2	12	F ANODE NO. 2
13	DIGIT NO. 2 ANODE	13	DIGIT NO. 2 CATHODE
14	DIGIT NO. 1 ANODE	14	DIGIT NO. 1 CATHODE
15	B CATHODE NO. 1	15	B ANODE NO. 1
16	A CATHODE NO. 1	16	A ANODE NO. 1
17	G CATHODE NO. 1	17	G ANODE NO. 1
18	F CATHODE NO. 1	18	F ANODE NO. 1

Absolute Maximum Ratings at $T_A = 25^\circ\text{C}$

Parameter	AlGaAs Red HDSP-52xA	
	Units	
Power Dissipation Segment	30	mW
Forward Current Segment	15 ^[1]	mA
Peak Forward Current per Segment (1/10 Duty Factor at 10 KHz)	80	mA
Operating Temperature Range	-35 to +85	°C
Storage Temperature Range	-35 to +85	°C
Reverse Voltage per Segment or DP	5	V
Wavesoldering Temperature for 3 seconds (at 2 mm Distance from the body)	250	°C

Notes:

1. Derate above 25°C at $0.2\text{ mA}/^\circ\text{C}$.

Intensity Bin Limits (mcd at 10 mA)

Bin Name	AlGaAs Red	
	Min. ^[1]	Max. ^[1]
J	3.201	5.050
K	5.051	8.000
L	8.001	12.650

Note:

1. Tolerance for each bin limit is $\pm 10\%$.

Electrical/Optical Characteristics at TA = 25°C

AlGaAs Red

Device HDSP-	Parameter	Symbol	Min.	Typ.	Max.	Units	Test Conditions
521A 523A	Luminous Intensity/Segment	I_V	3.201	3.66	6.500	mcd	$I_F = 5 \text{ mA}$
				mcd		$I_F = 10 \text{ mA}$	
	Forward Voltage	V_F		1.85	2.00	V	$I_F = 20 \text{ mA}$
	Peak Wavelength	λ_{PEAK}		660		nm	
	Dominant Wavelength	λ_d		643		nm	
	Reverse Voltage	V_R	5			V	$I_R = 100 \mu\text{A}$

AlGaAs Red

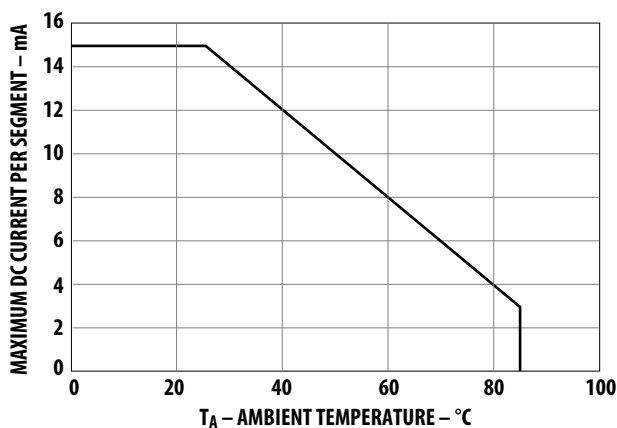

Figure 1. Maximum allowable average or DC current vs. ambient temperature.

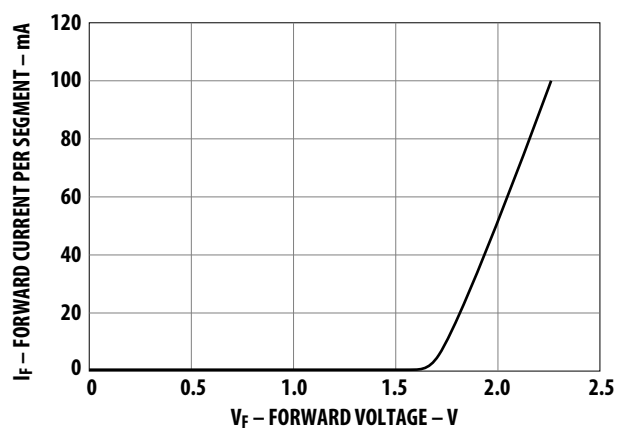

Figure 2. Forward current vs. forward voltage.

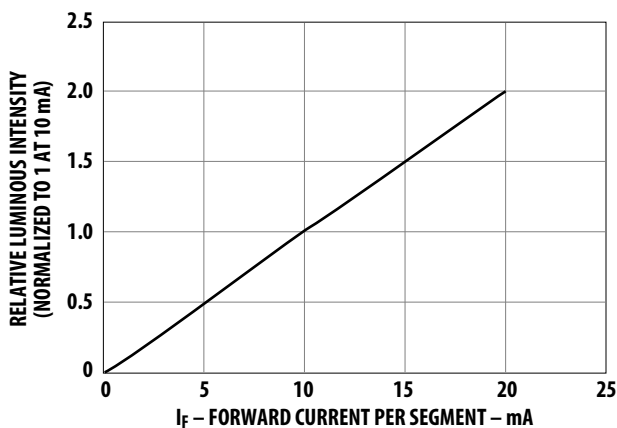

Figure 3. Relative luminous intensity vs. DC forward current.

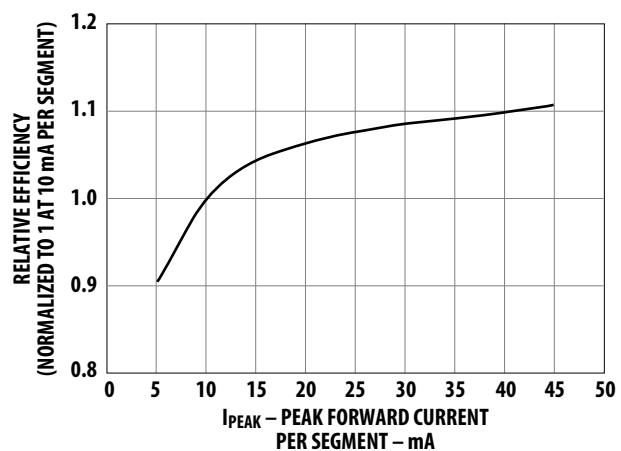

Figure 4. Relative efficiency (luminous intensity per unit current) vs. peak current.

For product information and a complete list of distributors, please go to our web site: www.avagotech.com



Компания «ЭлектроПласт» предлагает заключение долгосрочных отношений при поставках импортных электронных компонентов на взаимовыгодных условиях!

Наши преимущества:

- Оперативные поставки широкого спектра электронных компонентов отечественного и импортного производства напрямую от производителей и с крупнейших мировых складов;
- Поставка более 17-ти миллионов наименований электронных компонентов;
- Поставка сложных, дефицитных, либо снятых с производства позиций;
- Оперативные сроки поставки под заказ (от 5 рабочих дней);
- Экспресс доставка в любую точку России;
- Техническая поддержка проекта, помощь в подборе аналогов, поставка прототипов;
- Система менеджмента качества сертифицирована по Международному стандарту ISO 9001;
- Лицензия ФСБ на осуществление работ с использованием сведений, составляющих государственную тайну;
- Поставка специализированных компонентов (Xilinx, Altera, Analog Devices, Intersil, Interpoint, Microsemi, Aeroflex, Peregrine, Syfer, Eurofarad, Texas Instrument, Miteq, Cobham, E2V, MA-COM, Hittite, Mini-Circuits, General Dynamics и др.);

Помимо этого, одним из направлений компании «ЭлектроПласт» является направление «Источники питания». Мы предлагаем Вам помощь Конструкторского отдела:

- Подбор оптимального решения, техническое обоснование при выборе компонента;
- Подбор аналогов;
- Консультации по применению компонента;
- Поставка образцов и прототипов;
- Техническая поддержка проекта;
- Защита от снятия компонента с производства.



Как с нами связаться

Телефон: 8 (812) 309 58 32 (многоканальный)

Факс: 8 (812) 320-02-42

Электронная почта: org@eplast1.ru

Адрес: 198099, г. Санкт-Петербург, ул. Калинина, дом 2, корпус 4, литера А.