

10

9

8

7

6

5

4

3

2

1

F

E

D

C

B

A

F

E

D

C

B

A

8.5 [216]

1.2 [29]

0.3 [8]

1.0 [26]

ALL DIMENSIONS ARE FOR REFERENCE ONLY.

THIS LABEL IS DEPENDENT ON THE PLANT WHERE RETRACTOR IS BUILD & CUSTOMER THAT IS BUILT FOR. THUS POLAND PLANT WILL USE ONLY "ASSEMBLED IN POLAND" AND MEXICO PLANT WILL USE ONLY "ASSEMBLED IN MEXICO". CONTACT PLANT FOR SPECIFIC ITEM NUMBERS FOR THESE LABELS.

3.3 [83]

8.6 [218]

NOTES:

1. RETRACTORS ARE 100% INSPECTED & PRE-TENSIONED AT FACTORY.
2. STEEL HOUSINGS HAVE A POWDER COATED FINISH TO MEET HARSH INDUSTRIAL ENVIRONMENTS.
3. ALWAYS READ INSTRUCTIONS MANUAL BEFORE USING RETRACTORS.
4. RETRACTORS ARE NOT TO BE USED AS BALANCERS THEIR MAIN PURPOSE BEING TO RETRACT A LOAD AND NOT TO BALANCE ONE.
5. STANDARD RETRACTORS DO NOT COME EQUIPPED WITH A SAFETY CHAIN. IF APPLICATION REQUIRES A SAFETY CHAIN ADD "SC" SUFFIX TO STANDARD PART NUMBER. EXAMPLE 15FSC.
6. WHEN MOUNTING RETRACTOR, ALWAYS MAKE SURE THAT SAFETY PIN WHICH COMES WITH SHACKLE IS INSTALLED & SECURED.

RELEASE TO SALES	EC NO: WNA2009-0423	9/17/09	DRWN: RHOTCA	2009/09/17	CH'KD: DT	2009/09/25	APPR: DITITUS
REV	A						

QUALITY SYMBOLS	▽=0	▽C=0
-----------------	-----	------

GENERAL TOLERANCES (UNLESS SPECIFIED)		
	mm	INCH
4 PLACES	±NA	±---
3 PLACES	±NA	±NA
2 PLACES	±NA	±NA
1 PLACE	±NA	±NA
ANGULAR ±1°		
DRAFT WHERE APPLICABLE MUST REMAIN WITHIN DIMENSIONS		

DIMENSION STYLE	
IN/MM	
DRAWN BY	DATE
RH	2009/09/17
CHECKED BY	DATE
DT	2009/09/17
APPROVED BY	DATE
DTITUS	2009/09/24
MATERIAL NO.	
SEE TABLE	
SIZE	B

SCALE	NTS	DESIGN UNITS	INCH	THIRD ANGLE PROJECTION
TITLE				
10F/15F/22F SERIES OF RETRACTORS				
MOLEX INCORPORATED				
DOCUMENT NO.			SD-130175-002	SHEET NO.
				1 OF 2
THIS DRAWING CONTAINS INFORMATION THAT IS PROPRIETARY TO MOLEX INCORPORATED AND SHOULD NOT BE USED WITHOUT WRITTEN PERMISSION				

10

9

8

7

6

5

4

3

2

1

RETRACTOR MODEL:		ITEM #1:	ITEM #2:	ITEM #3:	ITEM 18 SAFETY CHAIN USAGE IN ASSEMBY:		RETRACTOR OUTER COLOR
MATERIAL NUMBER	ENGINEERING NUMBER	MATERIAL NUMBER	MATERIAL NUMBER	MATERIAL NUMBER	ENGINEERING NUMBER		
1301750001	10F	1301790115	1301790123	1301790124	N/A	N/A	BLUE
1301790006	15F	1301790115	1301790123	1301790125	N/A	N/A	BLUE
1301750011	22F	1301790115	1301790123	1301790125	N/A	N/A	BLUE
1301750005	10FSC	1301790115	1301790123	1301790124	1301790328	SSPEC	BLUE
1301790010	15FSC	1301790115	1301790123	1301790125	1301790328	SSPEC	BLUE
1301750013	22FSC	1301790115	1301790123	1301790125	1301790328	SSPEC	BLUE

LOAD CAPACITY CHART:			
RETRACTOR MODEL:		EACH RETRACT IS 100% TESTED UNDER THIS WEIGHT:	
MATERIAL NUMBER	ENGINEERING NUMBER	IN LBS:	IN KGS:
1301750001	10F	10	4.5
1301750006	15F	15	6.8
1301750011	22F	22	10

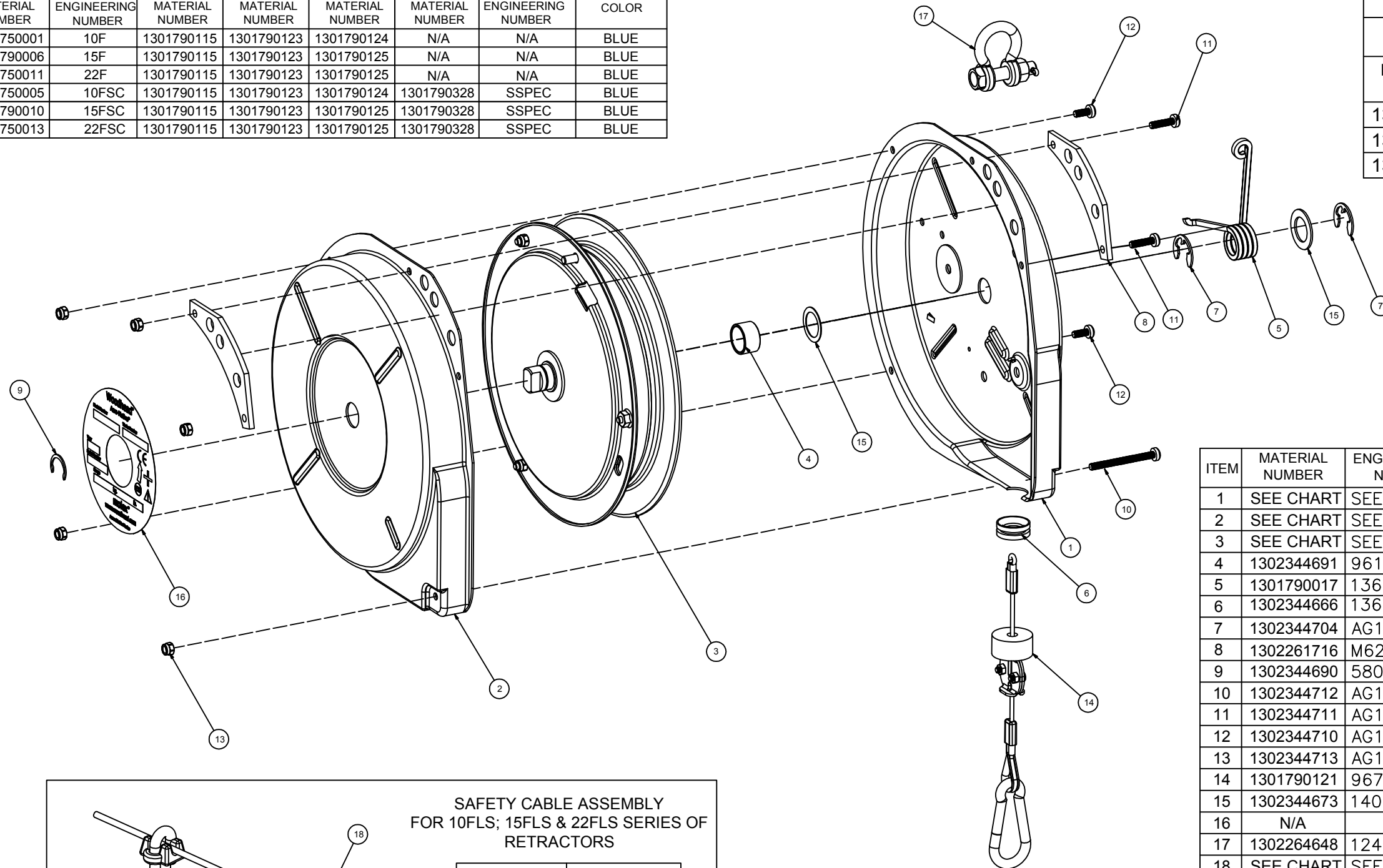

ITEM	MATERIAL NUMBER	ENGINEERING NUMBER	ITEM DESCRIPTION
1	SEE CHART	SEE CHART	10F/15F/22F HSNG SPRING SIDE - POWDER XXX
2	SEE CHART	SEE CHART	10F/15F/22F HSNG PLAIN SIDE - POWDER XXX
3	SEE CHART	SEE CHART	10F/15F/22F - ASSY SPRING & CABLE DRUM
4	1302344691	9611-1	MAIN SHAFT SPACER FOR 10F/15F/22F
5	1301790017	13611	TENSION LOCK SPRING
6	1302344666	13613	GUIDE - CABLE OUTLET
7	1302344704	AG10310	RET RING-ANDERTON N1500-62:BZP
8	1302261716	M62710002	HANGER BRACKET FOR 10F/15F/22F BALANCER
9	1302344690	580-P-35	EXTERNAL CIRCLIP 0.625" SHAFT
10	1302344712	AG14614	SCREW M4X45LG Posi PHD BZP
11	1302344711	AG14613	SCREW M4X16Lg Posi PHEAD BZP
12	1302344710	AG14612	SCREW M4X10LG Posi PHEAD BZP
13	1302344713	AG14615	M4 NYLOC NUT
14	1301790121	9678-8	8FT/2.4M ASSY CABLE FOR 10/15/22 F&FLR
15	1302344673	14099	WASHER -.63 I.D.x.88 O.D.x.02 W - BZP
16	N/A	N/A	ROUND LABEL SEE PLANT FOR INFO ON P/N
17	1302264648	1240-P-10	TOP SHACKLE ASSY WITH SAFETY PIN
18	SEE CHART	SEE CHART	SAFETY CABLE ASSY SEE CHART FOR USAGE

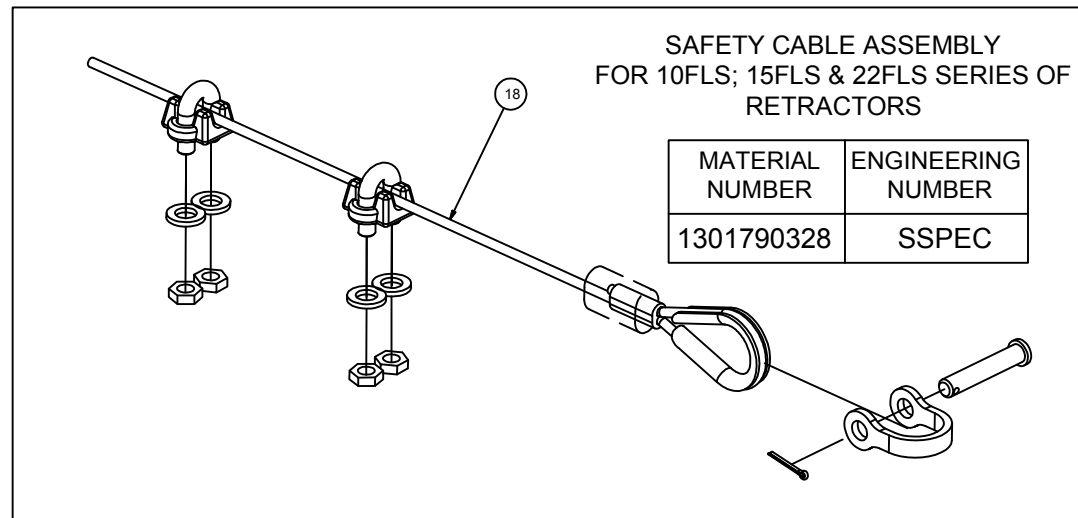

RELEASE TO SALES EC NO: WNA2009-0423 DRWN: RHOTCA CHKD: DT APPR: DITITUS 9/17/09 2009/09/17 2009/09/25	DESCRIPTION REV A	QUALITY SYMBOLS ▽=0 ▽=0	GENERAL TOLERANCES (UNLESS SPECIFIED) <table border="1"> <tr> <th></th> <th>mm</th> <th>INCH</th> </tr> <tr> <td>4 PLACES</td> <td>±NA</td> <td>±---</td> </tr> <tr> <td>3 PLACES</td> <td>±NA</td> <td>±NA</td> </tr> <tr> <td>2 PLACES</td> <td>±NA</td> <td>±NA</td> </tr> <tr> <td>1 PLACE</td> <td>±NA</td> <td>±NA</td> </tr> </table>		mm	INCH	4 PLACES	±NA	±---	3 PLACES	±NA	±NA	2 PLACES	±NA	±NA	1 PLACE	±NA	±NA	DIMENSION STYLE IN/MM DRAWN BY: RH DATE: 2009/09/17 CHECKED BY: DT DATE: 2009/09/17 APPROVED BY: DITITUS DATE: 2009/09/24	SCALE NTS DESIGN UNITS INCH THIRD ANGLE PROJECTION	TITLE 10F/15F/22F SERIES OF RETRACTORS MOLEX INCORPORATED SD-130175-002	SHEET NO. 2 OF 2
			mm	INCH																		
		4 PLACES	±NA	±---																		
		3 PLACES	±NA	±NA																		
2 PLACES	±NA	±NA																				
1 PLACE	±NA	±NA																				
DRAFT WHERE APPLICABLE MUST REMAIN WITHIN DIMENSIONS			MATERIAL NO. SEE TABLE	DOCUMENT NO. SD-130175-002	THIS DRAWING CONTAINS INFORMATION THAT IS PROPRIETARY TO MOLEX INCORPORATED AND SHOULD NOT BE USED WITHOUT WRITTEN PERMISSION																	



Компания «ЭлектроПласт» предлагает заключение долгосрочных отношений при поставках импортных электронных компонентов на взаимовыгодных условиях!

Наши преимущества:

- Оперативные поставки широкого спектра электронных компонентов отечественного и импортного производства напрямую от производителей и с крупнейших мировых складов;
- Поставка более 17-ти миллионов наименований электронных компонентов;
- Поставка сложных, дефицитных, либо снятых с производства позиций;
- Оперативные сроки поставки под заказ (от 5 рабочих дней);
- Экспресс доставка в любую точку России;
- Техническая поддержка проекта, помощь в подборе аналогов, поставка прототипов;
- Система менеджмента качества сертифицирована по Международному стандарту ISO 9001;
- Лицензия ФСБ на осуществление работ с использованием сведений, составляющих государственную тайну;
- Поставка специализированных компонентов (Xilinx, Altera, Analog Devices, Intersil, Interpoint, Microsemi, Aeroflex, Peregrine, Syfer, Eurofarad, Texas Instrument, Miteq, Cobham, E2V, MA-COM, Hittite, Mini-Circuits, General Dynamics и др.);

Помимо этого, одним из направлений компании «ЭлектроПласт» является направление «Источники питания». Мы предлагаем Вам помощь Конструкторского отдела:

- Подбор оптимального решения, техническое обоснование при выборе компонента;
- Подбор аналогов;
- Консультации по применению компонента;
- Поставка образцов и прототипов;
- Техническая поддержка проекта;
- Защита от снятия компонента с производства.



Как с нами связаться

Телефон: 8 (812) 309 58 32 (многоканальный)

Факс: 8 (812) 320-02-42

Электронная почта: org@eplast1.ru

Адрес: 198099, г. Санкт-Петербург, ул. Калинина, дом 2, корпус 4, литера А.