

## Applications

- Repeaters
- Mobile Infrastructure
- LTE / WCDMA / CDMA / GSM
- General Purpose Wireless
- TDD or FDD Systems

## Product Features

- 0.7-6.0 GHz Operational Bandwidth
- Ultra Low Noise Figure, 0.4 dB NF at 1.95 GHz
- High Gain, 20 dB Gain at 1.95 GHz
- High Linearity, +35 dBm Output IP3
- High Input Power Ruggedness, +22 dBm CW
- Unconditionally Stable
- Integrated On-chip Matching, 50 Ohm In/Out
- Integrated Active Bias
- Integrated Shutdown Control Pin
- +3V to +5V Supply; Does Not Require -V<sub>gg</sub>
- Pin Compatible with Low-Band TQP3M9036

## General Description

The TQP3M9037 is a high-linearity, ultra-low noise gain block amplifier in a small 2x2mm surface-mount package. At 1.95 GHz, the amplifier typically provides 20 dB gain, +35 dBm OIP3, and 0.4 dB noise figure while drawing 70 mA current from a +5 V supply. This amplifier does not require a negative supply for operation and can be biased from a single positive supply ranging from +3.3 to +5 volts. The device is housed in a green/RoHS-compliant industry-standard 2 x 2 mm package.

The TQP3M9037 is internally matched using a high performance E-pHEMT process and only requires four external components for operation from a single positive supply: an external RF choke and blocking/bypass capacitors. This low noise amplifier contains an internal active bias to maintain high performance over temperature and integrates a shut-down biasing capability to allow for operation for TDD applications.

The TQP3M9037 covers the 0.7–6.0 GHz frequency band and is targeted for wireless infrastructure. It is pin compatible with the low-band, 0.4–2.0 GHz TQP3M9036.

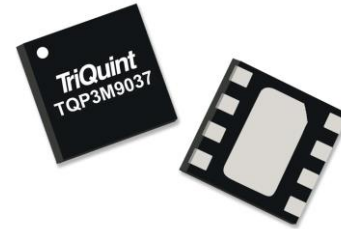

8 pin 2 x 2 mm DFN Package

## Functional Block Diagram

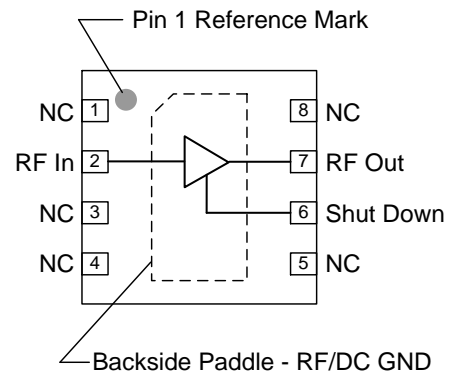

## Pin Configuration

Pin No.	Label
1, 3, 4, 5, 8	No Connect or GND
2	RF In
6	Shut Down
7	RF Out
Backside Paddle	RF/DC GND

## Ordering Information

Part No.	Description
TQP3M9037	Ultra low noise, High IP3 LNA
TQP3M9037-PCB	0.7–6.0 GHz Evaluation Board

Standard T/R size = 2500 pieces on a 7" reel

### Absolute Maximum Ratings

Parameter	Rating
Storage Temperature	-65 to +150 °C
Supply Voltage ( $V_{DD}$ )	+7 V
RF Input Power, CW, 50 $\Omega$ , $T=+25^{\circ}\text{C}$	+22 dBm

Operation of this device outside the parameter ranges given above may cause permanent damage.

### Recommended Operating Conditions

Parameter	Min	Typ	Max	Units
Supply Voltage ( $V_{DD}$ )	+3.3	+5.0	+5.25	V
$T_{CASE}$	-40		+105	°C
$T_j$ for $>10^6$ hours MTTF			+190	°C

Electrical specifications are measured at specified test conditions. Specifications are not guaranteed over all recommended operating conditions.

### Electrical Specifications

Test conditions unless otherwise noted:  $V_{DD}=+5\text{V}$ ,  $\text{Temp}=+25^{\circ}\text{C}$ , 50  $\Omega$  system.

Parameter	Conditions	Min	Typ	Max	Units
Operational Frequency Range		700		6000	MHz
Test Frequency			1950		MHz
Gain		18.5	20.0	21.5	dB
Input Return Loss			10		dB
Output Return Loss			11		dB
Noise Figure			0.40	0.65	dB
Output P1dB			+20		dBm
Output IP3	$P_{out}=+5\text{ dBm/ tone}$ , $\Delta f=1\text{ MHz}$	+32	+35		dBm
Power Shutdown Control ( $V_{PD}$ ) <sup>1</sup>	On state	0		0.4	V
	Off state (Power down)	2.5	3.3	$V_{DD}$	V
Current, $I_{DD}$	On state	40	70	90	mA
	Off state (Power down)		3	4	mA
Shutdown pin current, $I_{SD}$	$V_{PD} \geq +2.5\text{ V}$		140		$\mu\text{A}$
Thermal Resistance, $\theta_{jc}$	channel to case			53.4	°C/W

Notes:

1. This voltage is referred to the turret labelled PD on the TriQuint EVB as shown on pg. 4.

## S-Parameters

 Test Conditions:  $V_{DD}=+5\text{ V}$ ,  $I_{DD}=70\text{ mA}$  (typ.),  $T=+25^{\circ}\text{C}$ , unmatched 50 ohm system, calibrated to device leads

Freq (GHz)	S11 (dB)	S11 (ang)	S21 (dB)	S21 (ang)	S12 (dB)	S12 (ang)	S22 (dB)	S22 (ang)
0.05	-7.08	-13.38	28.74	173.92	-32.91	8.58	-15.03	0.20
0.10	-7.30	-16.67	28.70	169.79	-32.76	4.97	-14.12	2.20
0.20	-7.55	-27.25	28.51	160.47	-32.60	5.69	-13.67	-1.25
0.40	-7.89	-48.81	27.68	143.44	-32.47	8.81	-13.09	-6.33
0.60	-8.28	-67.86	26.67	128.94	-32.31	11.76	-12.61	-12.97
0.80	-8.67	-82.83	25.57	116.72	-31.94	14.83	-12.17	-19.29
1.00	-9.10	-96.01	24.54	106.22	-31.49	16.95	-11.87	-25.85
1.20	-9.48	-106.85	23.55	97.05	-30.96	17.84	-11.62	-31.76
1.40	-9.97	-116.61	22.63	88.79	-30.34	19.60	-11.45	-37.19
1.60	-10.36	-126.05	21.78	81.19	-29.81	19.78	-11.41	-42.80
1.80	-10.78	-135.06	20.99	74.13	-29.42	19.53	-11.43	-47.57
2.00	-11.14	-144.52	20.28	67.42	-28.85	19.14	-11.56	-53.18
2.20	-11.43	-153.91	19.61	60.92	-28.45	19.04	-11.79	-58.28
2.40	-11.54	-163.77	19.00	54.49	-27.99	17.71	-12.17	-64.71
2.60	-11.50	-174.25	18.41	48.28	-27.67	16.22	-12.63	-71.10
2.80	-11.30	175.64	17.86	41.94	-27.19	14.85	-13.20	-79.45
3.00	-10.90	166.39	17.33	35.76	-26.85	12.36	-13.86	-89.04
3.20	-10.45	157.46	16.79	29.69	-26.50	10.04	-14.51	-101.79
3.40	-9.89	150.34	16.29	23.57	-26.19	8.06	-14.74	-116.68
3.60	-9.29	144.41	15.76	17.56	-25.95	5.99	-14.57	-133.42
3.80	-8.86	140.00	15.22	11.78	-25.75	3.39	-13.78	-148.27
4.00	-8.32	136.87	14.67	6.13	-25.57	1.64	-12.70	-161.52
4.20	-8.03	133.99	14.10	0.74	-25.50	-1.15	-11.25	-169.83
4.40	-7.68	136.01	13.50	-4.52	-25.43	-2.83	-10.05	-178.99
4.60	-7.40	136.69	12.83	-9.19	-25.38	-4.24	-8.64	175.79
4.80	-7.21	140.78	12.13	-13.41	-25.53	-5.31	-7.25	170.49
5.00	-6.35	149.93	11.26	-16.91	-25.78	-6.38	-6.41	163.10

## Noise Parameters

 Test conditions unless otherwise noted:  $V_{DD}=+5\text{ V}$ ,  $I_{DD}=70\text{ mA}$  (typ.),  $\text{Temp}=+25^{\circ}\text{C}$ , 50 Ohm system

Freq (GHz)	NF <sub>min</sub> (dB)	MagOpt (mag)	AngOpt (deg)	Rn (Ω)
1.5	0.40	0.15	14.1	0.08
1.7	0.29	0.16	43.7	0.06
1.8	0.3	0.13	55.1	0.06
1.9	0.30	0.11	30.2	0.06
2	0.32	0.11	65.3	0.05
2.1	0.32	0.13	77.6	0.05
2.2	0.35	0.14	89.0	0.05
2.4	0.43	0.06	85.8	0.05
2.5	0.51	0.02	42.1	0.06
2.6	0.46	0.08	157.4	0.04
2.7	0.46	0.07	148.6	0.05

**$\Gamma_{opt}$  and  $S_{11}^*$**

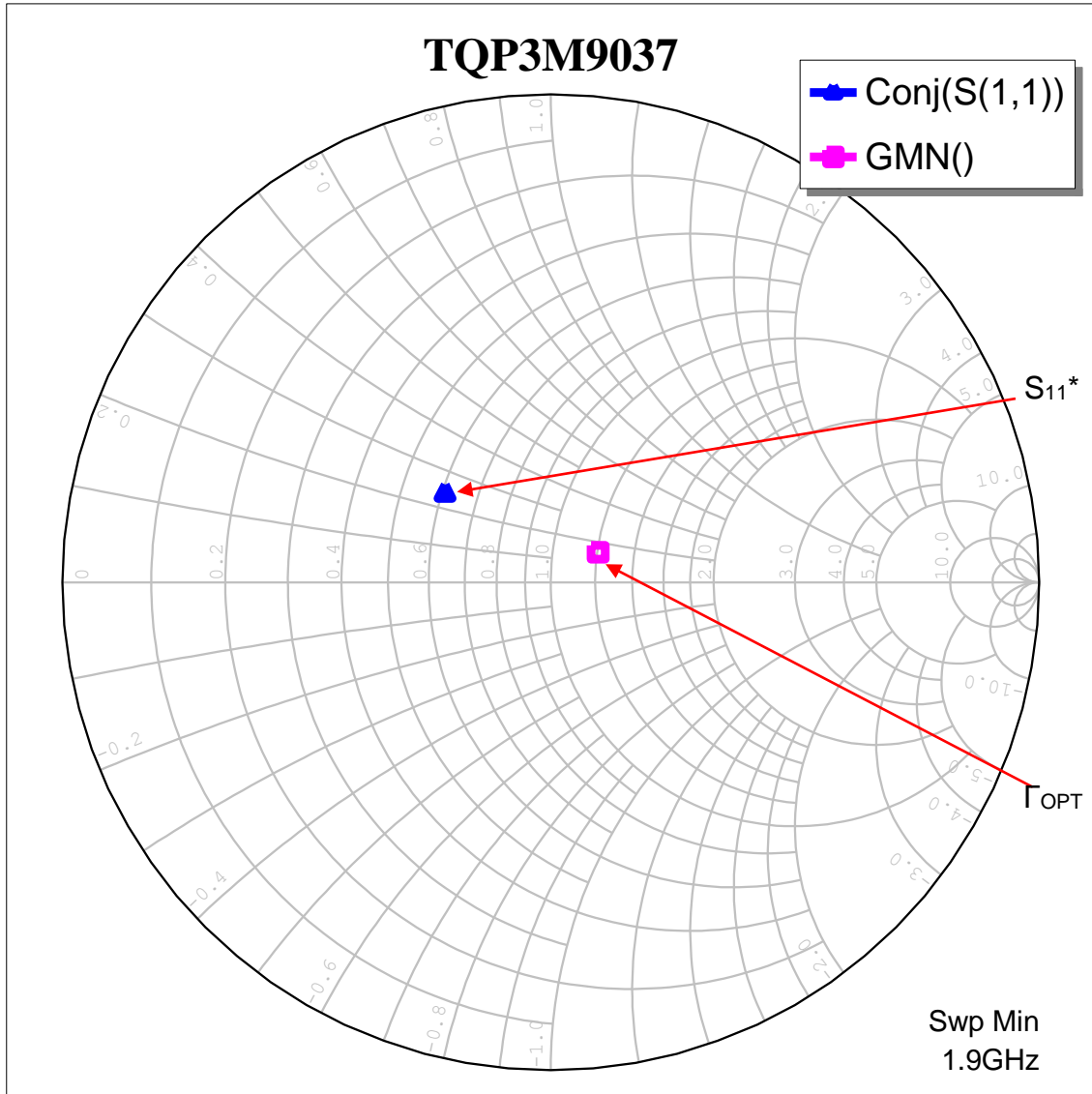

**TQP3M9037-PCB Evaluation Board**

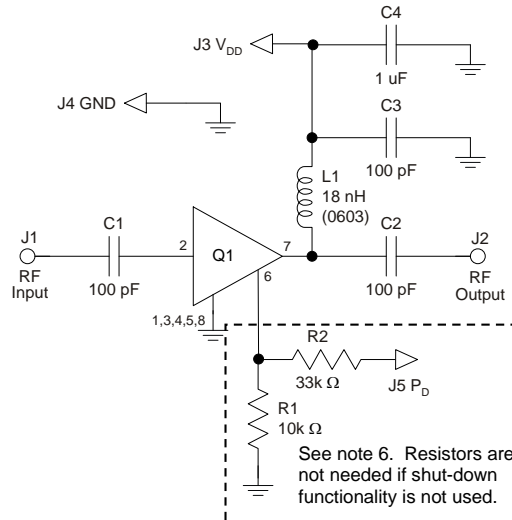
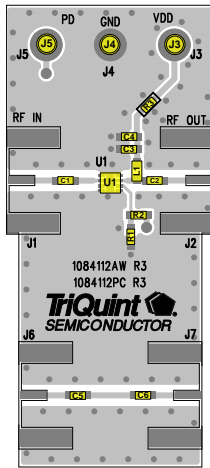

**Notes:**

1. See Evaluation Board PCB Information section for material and stack-up.
2. R3 (0 Ω jumper) is not shown on the schematic and may be replaced with copper trace in the target application layout.
3. All components are of 0402 size unless stated on the schematic.
4. C1, C2, and C3 are non-critical values. The reactive impedance should be as low as possible at the frequency of operation for optimal performance.
5. The L1 value is non-critical and needs to provide high reactive impedance at the frequency of operation.
6. R1 and R2 are optional and do not need to be loaded if the shut-down functionality is not needed; i.e. FDD applications. If R1 and R2 are not loaded, the LNA will operate in its standard “ON” state.
7. A through line is included on the evaluation board to de-embed the board losses.

**Bill of Material – TQP3M9037-PCB**

Reference Des.	Value	Description	Manuf.	Part Number
N/A	N/A	Printed Circuit Board	TriQuint	1084112
U1	n/a	Ultra Low Noise, High Linearity LNA	TriQuint	TQP3M9037
R1	10 kΩ	Resistor, Chip, 0402, 5%, 1/16W	various	
R2	33 kΩ	Resistor, Chip, 0402, 5%, 1/16W	various	
R3	0 Ω	Resistor, Chip, 0402, 5%, 1/16W	various	
L1	18 nH	Inductor, 0603, 5%, Ceramic	various	
C4	1.0 uF	Cap., Chip, 0402, 10%, 10V, X5R	various	
C1, C2, C3, C5, C6	100 pF	Cap., Chip, 0402, 5%, 50V, NPO/COG	various	

**Resistive Divider Values**

V <sub>PD</sub> Signal Level	+3.3 V TTL	+2.5 V TTL	+1.8 V TTL	Units
R1	10 kΩ	11 kΩ	12 kΩ	Ω
R2	33 kΩ	33 kΩ	33 kΩ	Ω

**Typical Performance – TQP3M9037-PCB  $V_{DD} = +5 V$**

Test conditions unless otherwise noted:  $V_{DD}=+5 V$ ,  $I_{DD}=70 mA$  (typ.), Temp= $+25^{\circ}C$

Parameter	Conditions	Typical Values					Units
Frequency		900	1700	1950	2300	2600	MHz
Gain		25.3	21.4	20.4	19.1	18.1	dB
Input Return Loss		7.4	9.6	10.1	10.5	10.9	dB
Output Return Loss		11.7	11.6	11.0	10.2	9.8	dB
Output P1dB		+22	+20.7	+20	+19.8	+19.5	dBm
OIP3	Pout=+5 dBm/tone, $\Delta f=1 MHz$	+34.4	+34.9	+35.7	+35.1	+35.0	dBm
Noise figure <sup>(1)</sup>		0.4	0.36	0.41	0.43	0.53	dB

Notes:

- Noise figure data shown in the table above is de-embedded to the device pin pads.

**Performance Plots – TQP3M9037-PCB  $V_{DD} = +5 V$**

Test conditions unless otherwise noted:  $V_{DD}=+5 V$ ,  $I_{DD}=70 mA$  (typ.), Temp= $+25^{\circ}C$

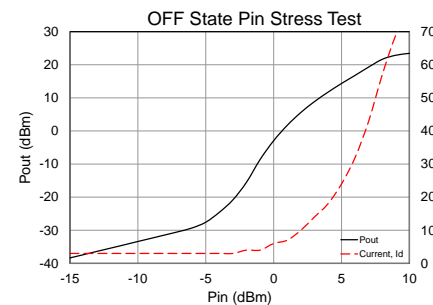
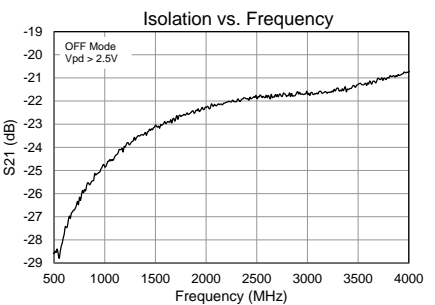
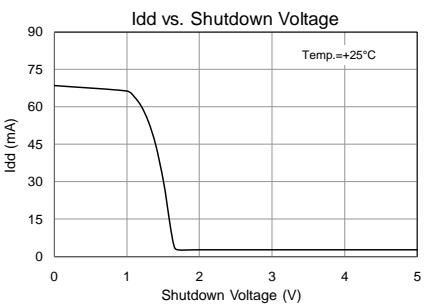
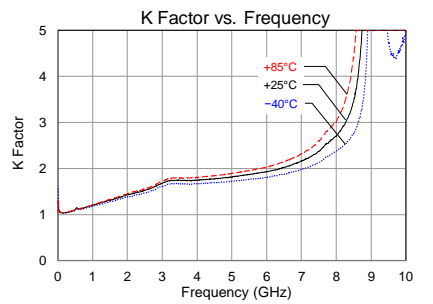
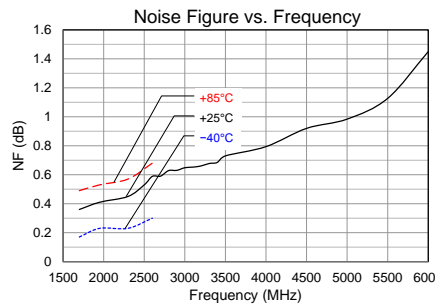
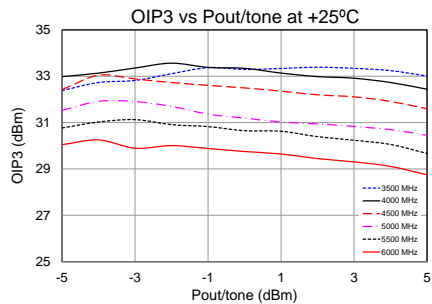
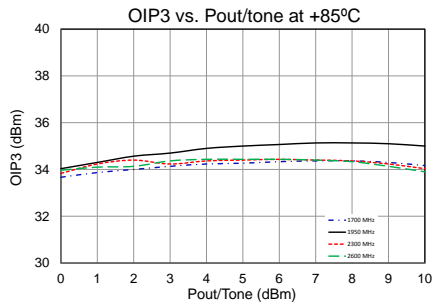
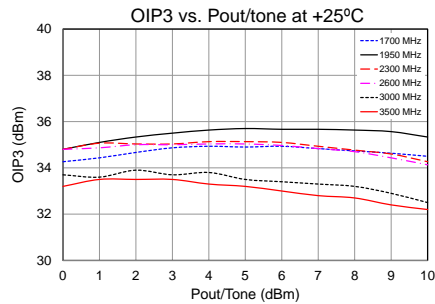
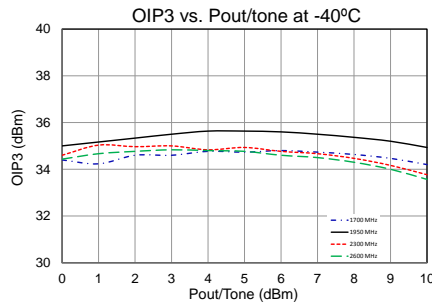
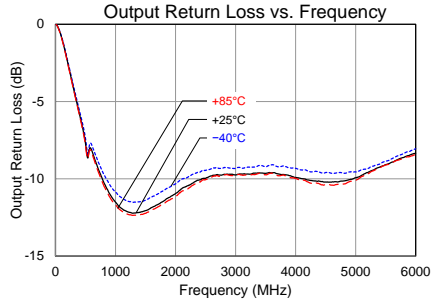
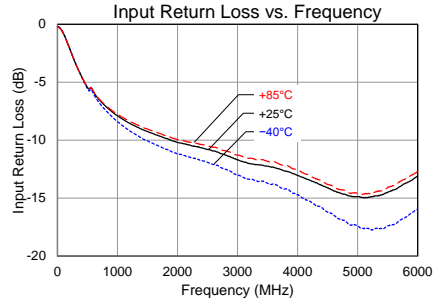
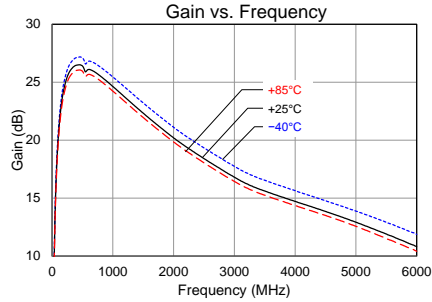

**Typical Performance – TQP3M9037-PCB  $V_{DD} = +3.3V$**

Test conditions unless otherwise noted:  $V_{DD} = +3.3V$ ,  $I_{DD} = 44\text{ mA}$  (typ.), Temp= +25°C

Parameter	Conditions	Typical Values				Units
Frequency		1700	1950	2300	2600	MHz
Gain		19.9	19.2	17.7	17.0	dB
Input Return Loss		8.3	9.2	9.5	10.5	dB
Output Return Loss		11.3	11.3	9.5	9.5	dB
Output P1dB		+16.2	+16.1	+15.5	+15.5	dBm
OIP3	$P_{out} = +5\text{ dBm/ tone}, \Delta f = 1\text{ MHz}$	+30.6	+31	+30.5	+30.7	dBm
Noise figure <sup>(1)</sup>		0.4	0.38	0.44	0.53	dB

Notes:

- Noise figure data shown in the table above is de-embedded from the eval board loss.

**Performance Plots – TQP3M9037-PCB  $V_{DD} = +3.3V$**

Test conditions unless otherwise noted:  $V_{DD} = +3.3V$ ,  $I_{DD} = 44\text{ mA}$  (typ.), Temp= +25°C

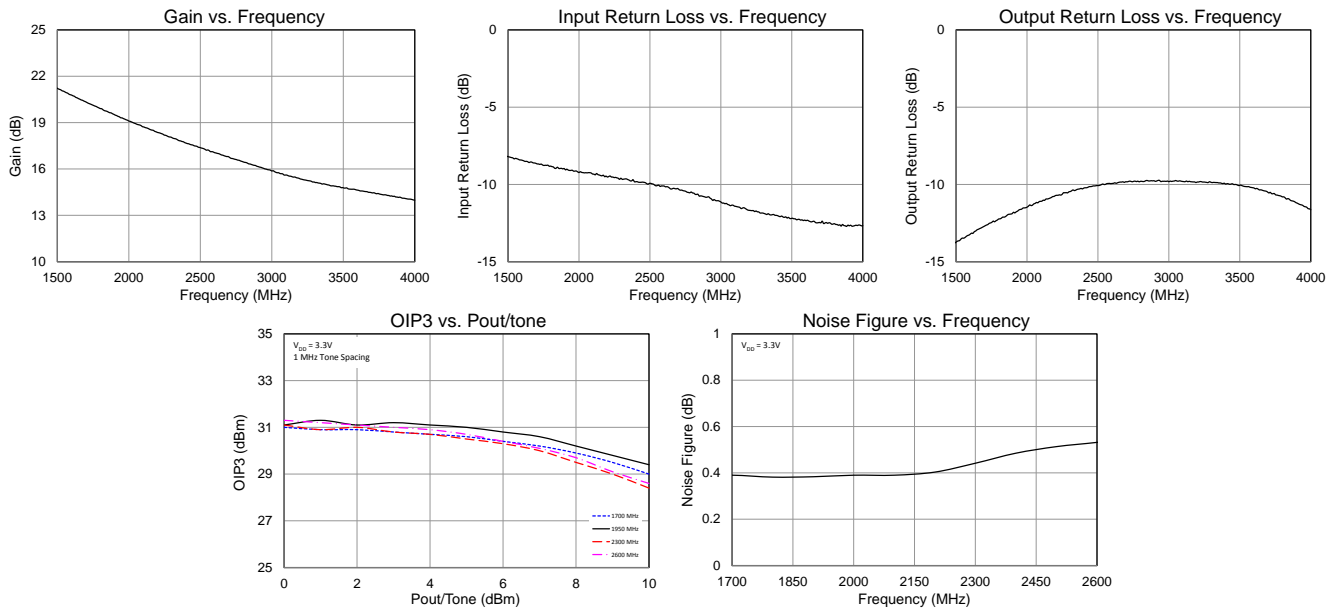



**Reference Design – Optimized Return Loss**

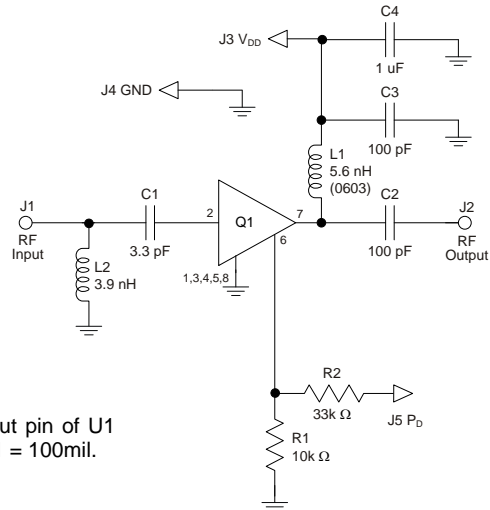
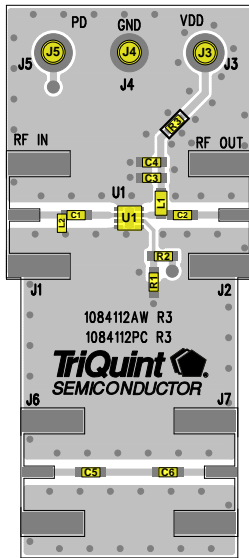

Notes:  
1. Distance from input pin of U1 to right edge of C1 = 100mil.

**Bill of Material**

Reference Des.	Value	Description	Manuf.	Part Number
n/a	n/a	Printed Circuit Board	TriQuint	1084112
U1	n/a	Ultra Low Noise Amplifier	TriQuint	TQP3M9037
R1	10 kΩ	Resistor, Chip, 0402, 5%, 1/16W	various	
R2	33 kΩ	Resistor, Chip, 0402, 5%, 1/16W	various	
R3	0 Ω	Resistor, Chip, 0402, 5%, 1/16W	various	
L1	5.6 nH	Inductor, 0603, 5%, Ceramic	various	
L2	3.9 nH	Inductor, 0402, 5%, Ceramic	various	
C1	3.3 pF	Cap, Chip, 0402, ±0.25 pF, 50V, NPO/COG	various	
C4	1.0 uF	Cap, Chip, 0402, 10%, 10V, X5R	various	
C2, C3, C5, C6	100 pF	Cap, Chip, 0402, 5%, 50V, NPO/COG	various	

**Performance Plots**

Test conditions unless otherwise noted: V<sub>DD</sub> = +5V, I<sub>DD</sub> = 70 mA (typ.), Temp = +25°C

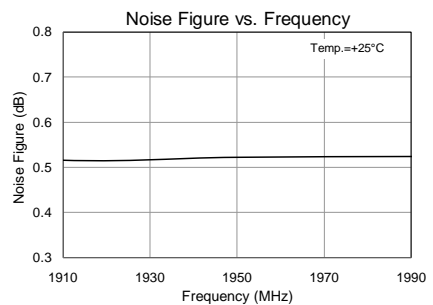
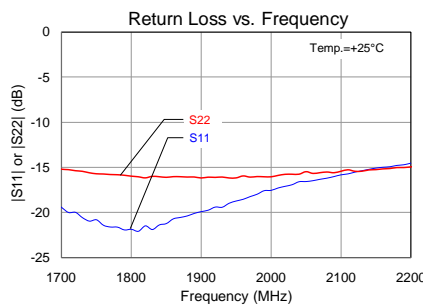
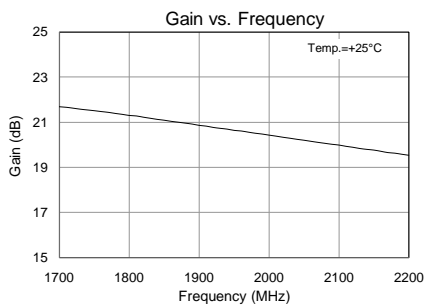

**Evaluation Board: 2300 – 2600 MHz Reference Design**

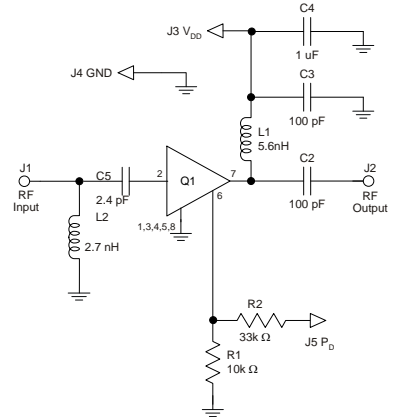
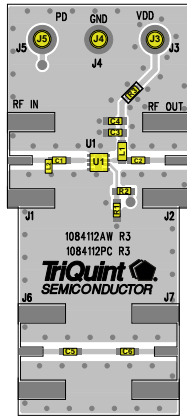

**Performance Plots: 2300 – 2600 MHz Reference Design**

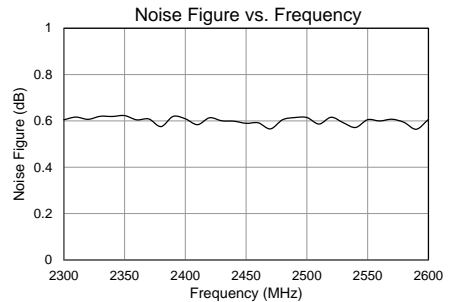
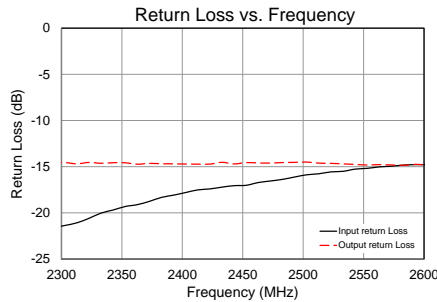
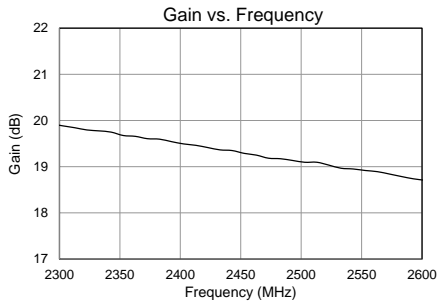

**Bill of Material: 2300 – 2600 MHz Reference Design**

Reference Des.	Value	Description	Manuf.	Part Number
n/a	n/a	Printed Circuit Board	TriQuint	
U1	n/a	Ultra Low Noise Amplifier	TriQuint	TQP3M9037
R1	10 kΩ	Resistor, Chip, 0402, 5%, 1/16W	various	
R2	33 kΩ	Resistor, Chip, 0402, 5%, 1/16W	various	
R3	0 Ω	Resistor, Chip, 0402, 5%, 1/16W	various	
L1	5.6 nH	Inductor, 0603, 5%, Ceramic	Coilcraft	0603CS-5N6XJL
L2	2.7 nH	Inductor, 0402, 5%, Ceramic	TOKO	LL1005-FHL2N7S
C1	2.4 pF	Cap, Chip, 0402, ±0.25 pF, 50V, NPO/COG	AVX	04023J2R4BBSTR
C4	1.0 uF	Cap, Chip, 0402, 10%, 10V, X5R	various	
C2, C3, C5, C6	100 pF	Cap, Chip, 0402, 5%, 50V, NPO/COG	various	

**Evaluation Board: 3400 -3600 MHz Reference Design**

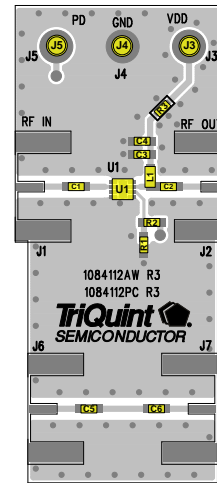
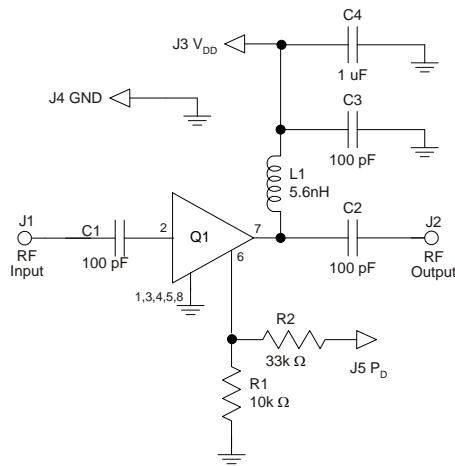

**Performance Plots: 3400 -3600 MHz Reference Design**

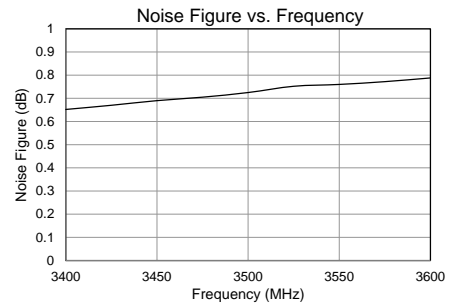
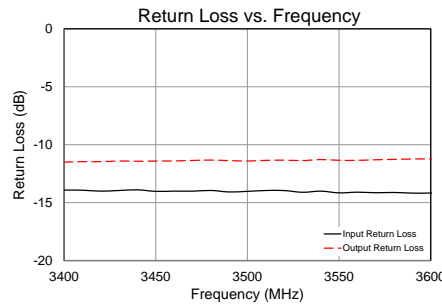
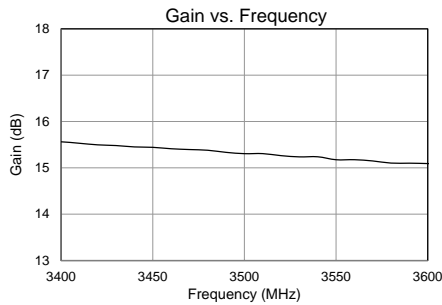

**Bill of Material: 3400 -3600 MHz Reference Design**

Reference Des.	Value	Description	Manuf.	Part Number
n/a	n/a	Printed Circuit Board	TriQuint	
U1	n/a	Ultra Low Noise Amplifier	TriQuint	TQP3M9037
R1	10K $\Omega$	Resistor, Chip, 0402, 5%, 1/16W	various	
R2	33K $\Omega$	Resistor, Chip, 0402, 5%, 1/16W	various	
R3	0 $\Omega$	Resistor, Chip, 0402, 5%, 1/16W	various	
L1	5.6 nH	Inductor, 0603, 5%, Ceramic	Coilcraft	0603CS-5N6XJL
C4	1.0 uF	Cap, Chip, 0402, 10%, 10V, X5R	various	
C1, C2, C3, C5, C6	100 pF	Cap, Chip, 0402, 5%, 50V, NPO/COG	various	

**+3.3 V V<sub>DD</sub> Performance Improvement with External Input Bias**

This page shows performance data of TQP3M9037 tuned for better input return loss for B7 UL. The device is biased at 3.3V V<sub>dd</sub>. At this bias voltage the device draws about 45mA I<sub>dd</sub> but the OIP3 drops by almost 5dB. To improve the linearity performance an external bias is introduced to the input port by a resistive divider tied to the 3.3V. This results in increased current draw of about 60mA and the OIP3 is up by 5dB.

**Performance Plots**

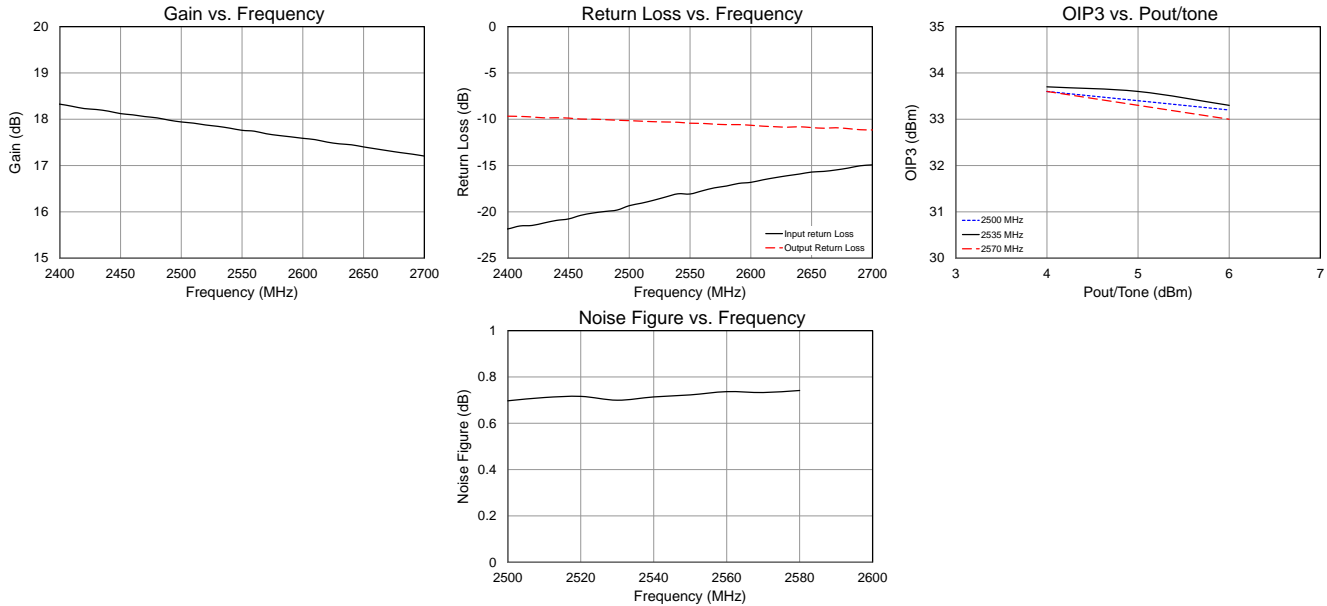

**Evaluation Board**

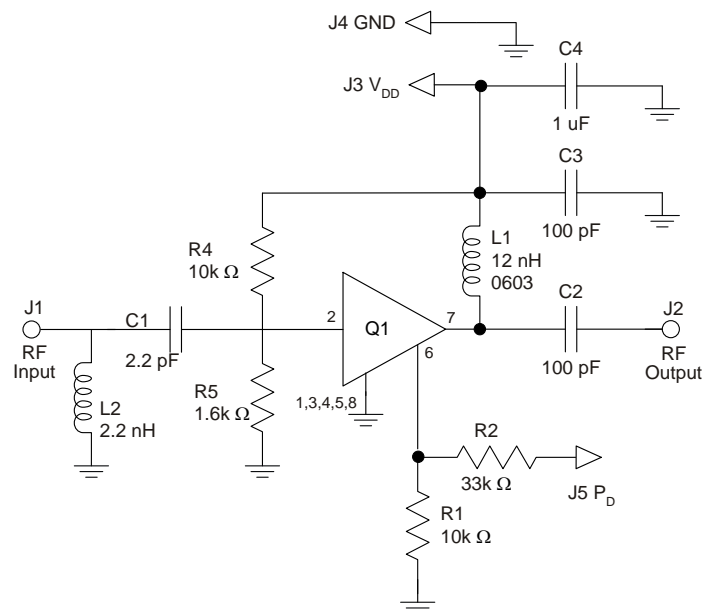
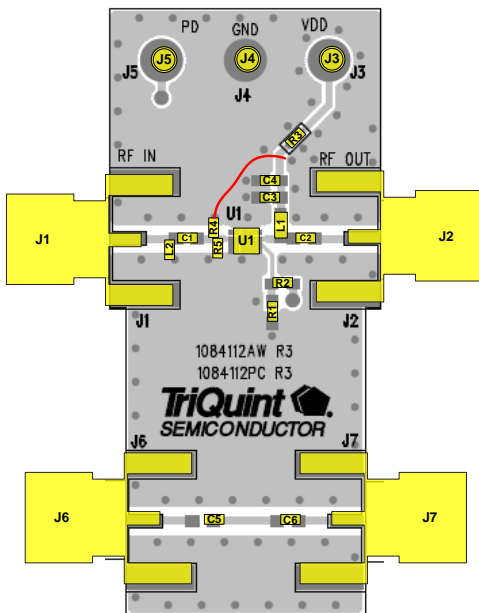

**+5 V V<sub>DD</sub> Reduced Current Reference Design**

This page shows performance data of TQP3M9037 with reduced current consumption of around 40mA. The V<sub>dd</sub> is kept at +5V and to reduce the current a shunt resistor of 36K ohms is added at the input pin. This drops the gate voltage of the input transistor and hence bringing the bias point of the LNA down.

**Performance Plots**

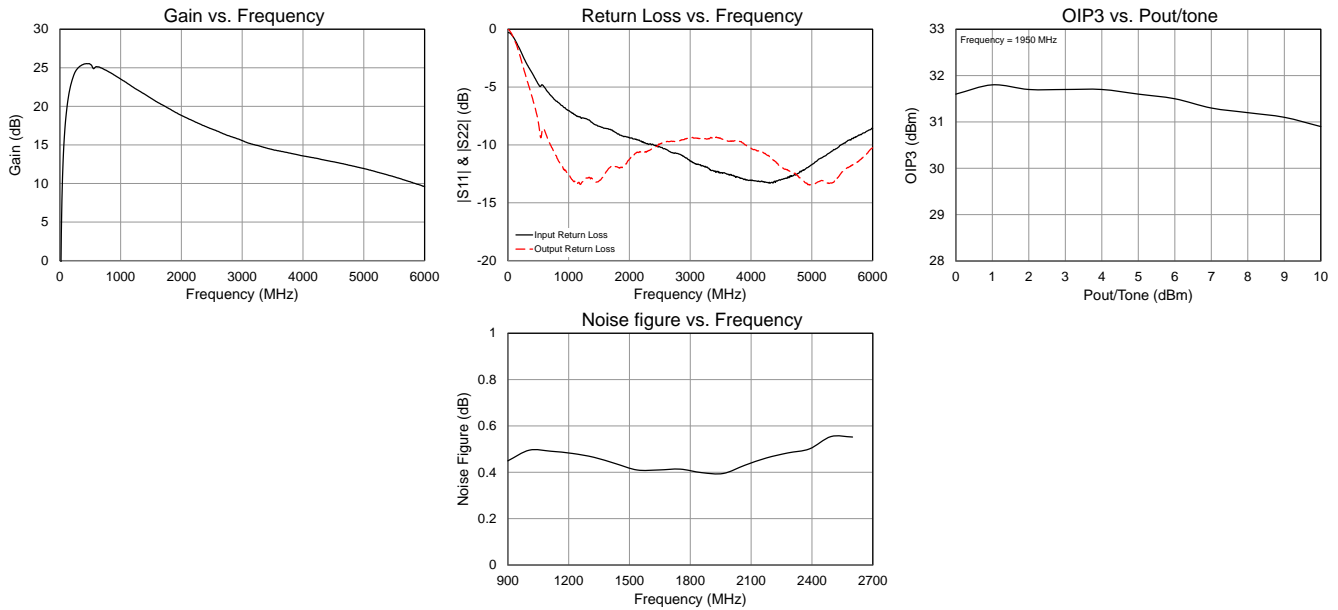

**Evaluation Board**

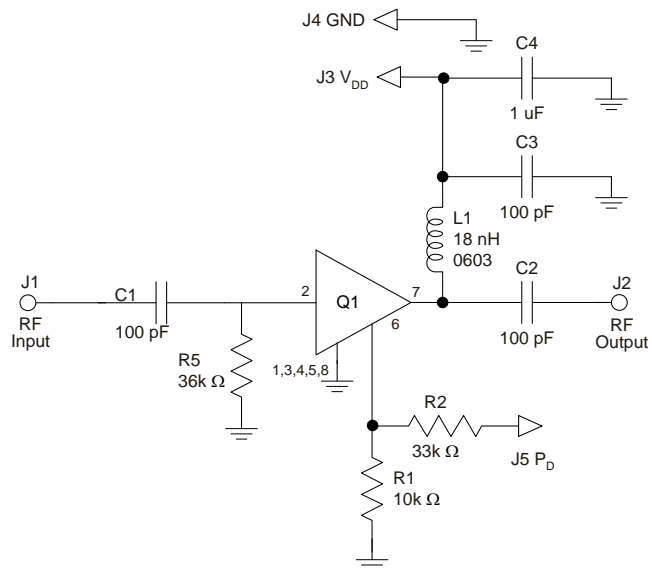
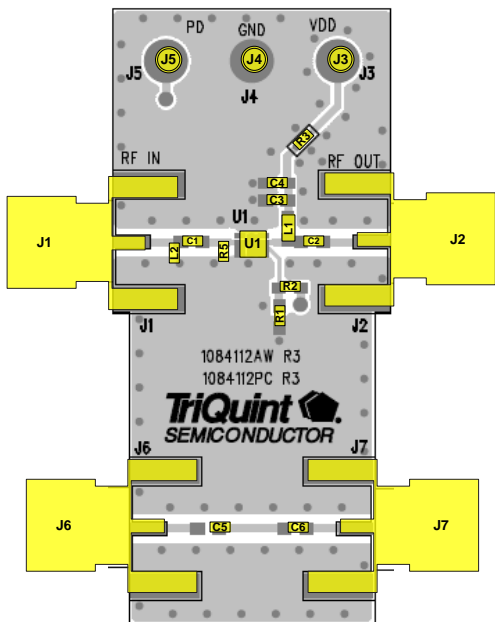

**Switching Speed**

Switching Speed Measurement based on TQS Application Board shown on pg. 4.  
 $V_{PD}$  toggled with a 100Hz square wave(0-3V),  $V_{DD}=5V$

Parameter	C1=100pF	C1=10pF	Units
Turn-off Transition (50% TTL – 10% RF)	0.5	0.15	$\mu s$
Turn-on Transition (50% TTL – 90% RF)	1.45	0.23	$\mu s$

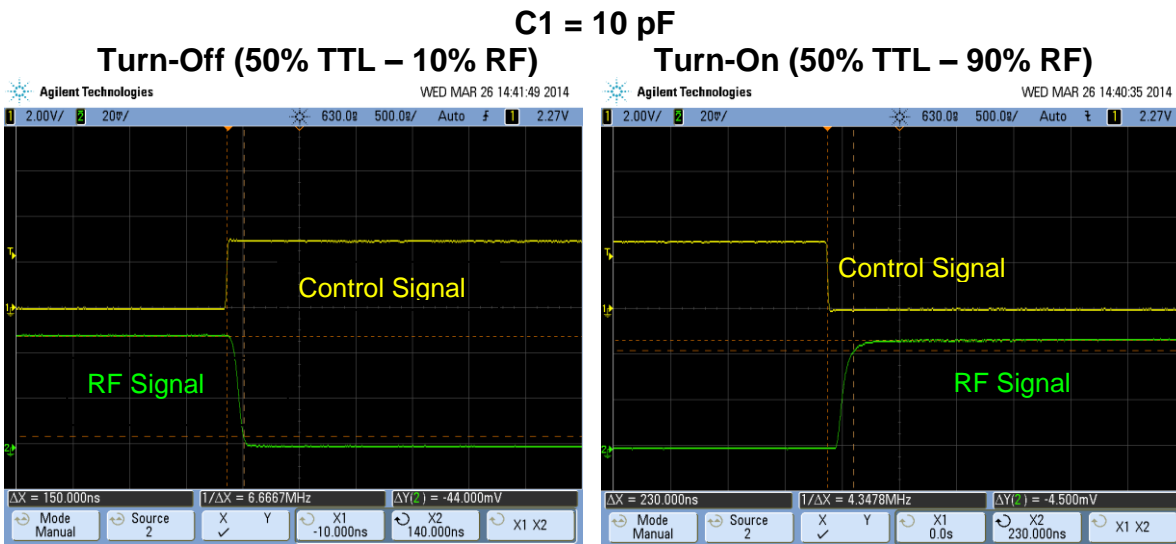
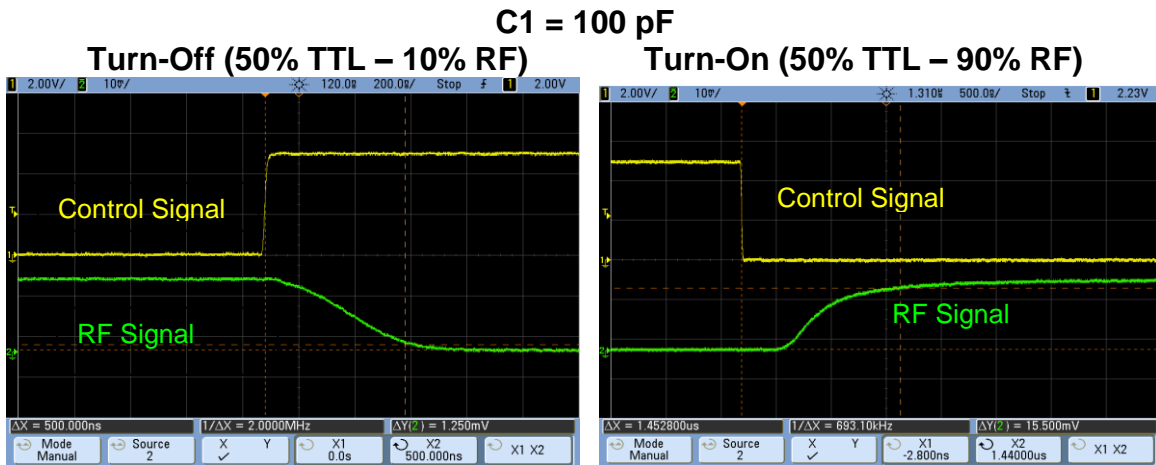

**Pin Configuration and Description**

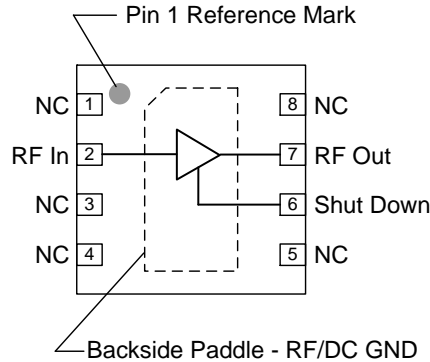

Pin No.	Label	Description
2	RF In	RF Input pin. A DC Block is required.
6	Shut Down	A high voltage turns off the device. If the pin is not connected or is less than 1V, then the device will operate under its normal operating condition.
7	RF Out / DCBias	RF Output pin. DC bias will also need to be injected through a RF bias choke/inductor for operation.
1, 3, 4, 5, 8	NC	No electrical connection. Provide grounded land pads for PCB mounting integrity.
Backside Paddle	RF/DC GND	RF/DC ground. Use recommended via pattern to minimize inductance and thermal resistance; see PCB Mounting Pattern for suggested footprint.

**Evaluation Board PCB Information**

TriQuint PCB 1084112 Material and Stack-up

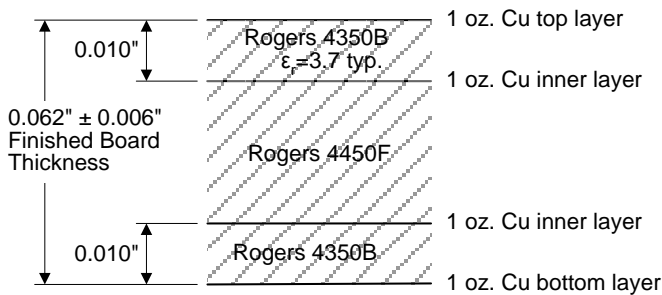

50 ohm line dimensions: width = 0.020", spacing = 0.032"

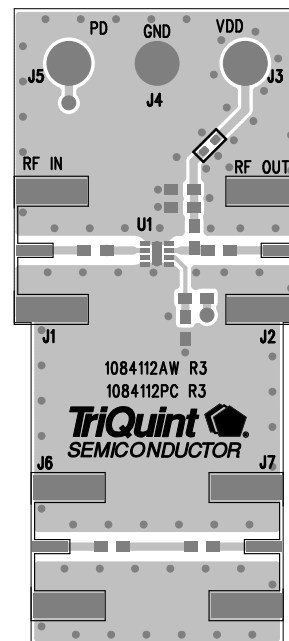

**Mechanical Information**

**Package Marking and Dimensions**

Marking: Part number – 9037  
 Lot code – XXXX

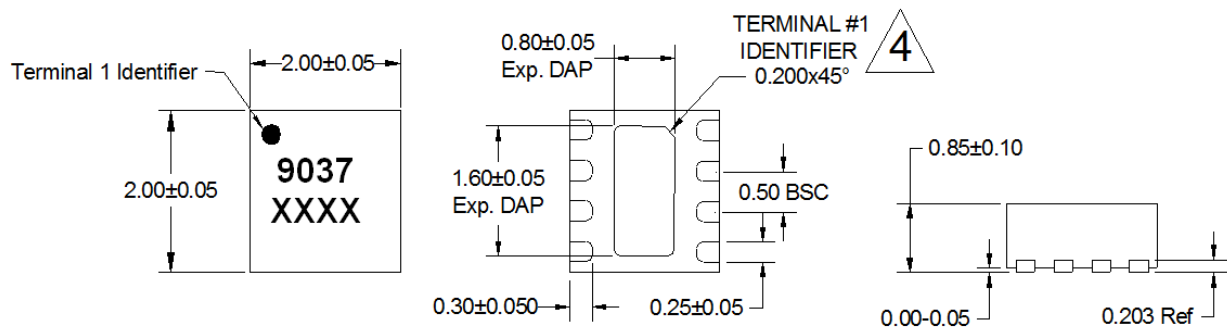

Notes:

1. All dimensions are in millimeters. Angles are in degrees.
2. Except where noted, this part outline conforms to JEDEC standard MO-220, Issue E (Variation VGGC) for thermally enhanced plastic very thin fine pitch quad flat no lead package (QFN).
3. Dimension and tolerance formats conform to ASME Y14.4M-1994.
4. The terminal #1 identifier and terminal numbering conform to JESD 95-1 SPP-012.

**PCB Mounting Pattern**

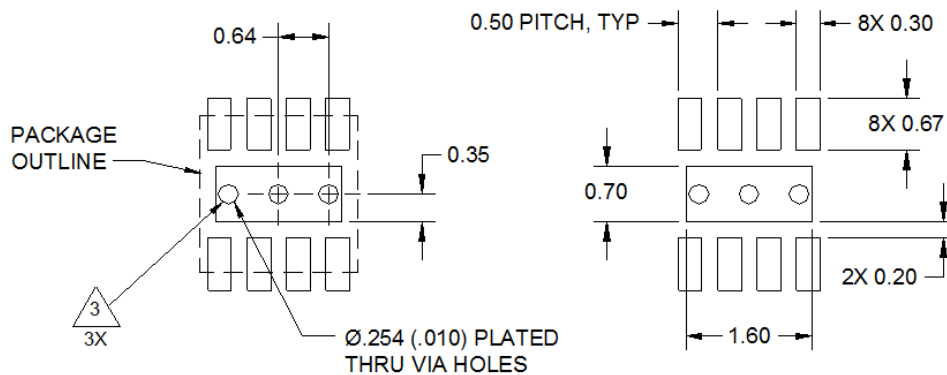

Notes:

1. All dimensions are in millimeters. Angles are in degrees.
2. Use 1 oz. copper minimum for top and bottom layer metal.
3. Vias are required under the backside paddle of this device for proper RF/DC grounding and thermal dissipation. We recommend a 0.35mm (#80/.0135") diameter bit for drilling via holes and a final plated thru diameter of 0.25 mm (0.10").
4. Ensure good package backside paddle solder attach for reliable operation and best electrical performance.



**Product Compliance Information**

**ESD Sensitivity Ratings**



Caution! ESD-Sensitive Device

ESD Class: 1A  
 Volt. Range: ≥ 250 V to < 500 V  
 Test: Human Body Model (HBM)  
 Standard: ESDA/JEDEC Standard JS-001-2012

ESD Class: C2  
 Volt. Range: 500 V to < 1000 V  
 Test: Charged Device Model (CDM)  
 Standard: JEDEC Standard JESD22-C101

**MSL Rating**

MSL Rating: Level 1  
 Test: 260 °C convection reflow  
 Standard: JEDEC Standard IPC/JEDEC J-STD-020

**Solderability**

Compatible with both lead-free (260 °C max. reflow temperature) and tin/lead (245 °C max. reflow temperature) soldering processes.

Contact plating: NiPdAu

**RoHS Compliance**

This part is compliant with EU 2002/95/EC RoHS directive (Restrictions on the Use of Certain Hazardous Substances in Electrical and Electronic Equipment).

This product also has the following attributes:

- Lead Free
- Halogen Free (Chlorine, Bromine)
- Antimony Free
- TBBP-A (C<sub>15</sub>H<sub>12</sub>Br<sub>4</sub>O<sub>2</sub>) Free
- PFOS Free
- SVHC Free

**Contact Information**

For the latest specifications, additional product information, worldwide sales and distribution locations:

**Web:** [www.triquint.com](http://www.triquint.com)      **Tel:** 877-800-8584  
**Email:** [customer.support@qorvo.com](mailto:customer.support@qorvo.com)

For information about the merger of RFMD and TriQuint as Qorvo:

**Web:** [www.qorvo.com](http://www.qorvo.com)

For technical questions and application information:

**Email:** [sjcapplications.engineering@qorvo.com](mailto:sjcapplications.engineering@qorvo.com)

**Important Notice**

The information contained herein is believed to be reliable. TriQuint makes no warranties regarding the information contained herein. TriQuint assumes no responsibility or liability whatsoever for any of the information contained herein. TriQuint assumes no responsibility or liability whatsoever for the use of the information contained herein. The information contained herein is provided "AS IS, WHERE IS" and with all faults, and the entire risk associated with such information is entirely with the user. All information contained herein is subject to change without notice. Customers should obtain and verify the latest relevant information before placing orders for TriQuint products. The information contained herein or any use of such information does not grant, explicitly or implicitly, to any party any patent rights, licenses, or any other intellectual property rights, whether with regard to such information itself or anything described by such information.

TriQuint products are not warranted or authorized for use as critical components in medical, life-saving, or life-sustaining applications, or other applications where a failure would reasonably be expected to cause severe personal injury or death.



Компания «ЭлектроПласт» предлагает заключение долгосрочных отношений при поставках импортных электронных компонентов на взаимовыгодных условиях!

Наши преимущества:

- Оперативные поставки широкого спектра электронных компонентов отечественного и импортного производства напрямую от производителей и с крупнейших мировых складов;
- Поставка более 17-ти миллионов наименований электронных компонентов;
- Поставка сложных, дефицитных, либо снятых с производства позиций;
- Оперативные сроки поставки под заказ (от 5 рабочих дней);
- Экспресс доставка в любую точку России;
- Техническая поддержка проекта, помощь в подборе аналогов, поставка прототипов;
- Система менеджмента качества сертифицирована по Международному стандарту ISO 9001;
- Лицензия ФСБ на осуществление работ с использованием сведений, составляющих государственную тайну;
- Поставка специализированных компонентов (Xilinx, Altera, Analog Devices, Intersil, Interpoint, Microsemi, Aeroflex, Peregrine, Syfer, Eurofarad, Texas Instrument, Miteq, Cobham, E2V, MA-COM, Hittite, Mini-Circuits, General Dynamics и др.);

Помимо этого, одним из направлений компании «ЭлектроПласт» является направление «Источники питания». Мы предлагаем Вам помощь Конструкторского отдела:

- Подбор оптимального решения, техническое обоснование при выборе компонента;
- Подбор аналогов;
- Консультации по применению компонента;
- Поставка образцов и прототипов;
- Техническая поддержка проекта;
- Защита от снятия компонента с производства.



#### Как с нами связаться

**Телефон:** 8 (812) 309 58 32 (многоканальный)

**Факс:** 8 (812) 320-02-42

**Электронная почта:** [org@eplast1.ru](mailto:org@eplast1.ru)

**Адрес:** 198099, г. Санкт-Петербург, ул. Калинина, дом 2, корпус 4, литера А.