

Aluminum Electrolytic Capacitors - Accessories (Vishay BCcomponents)

RESISTORS FOR TERMINAL MOUNTING

Resistors are used to balance the voltage over a series connection of screw terminal capacitors or to ensure discharge to a safe voltage after power down. Vishay provides the [CMS series of resistors](#), which are suited for direct mounting on the terminals of screw terminal capacitors.

DIMENSIONS in inches [millimeters]							
DIAMETER	MODEL	CORE DIMENSIONS in inch [mm]				TERMINAL DESIGNATION	
		A TYPICAL	B ± 0.031 [0.79]	C ± 0.062 [1.59]	M ± 0.0118 [0.3]	CM HOLE DIAMETER TYPICAL	CA HOLE DIAMETER TYPICAL
Ø 50 mm	CMS16	0.562 [14.27]	0.312 [7.92]	1.250 [31.75]	0.875 [22.23]	0.196 [4.98]	0.265
Ø 65 mm	CMS20	0.562 [14.27]	0.312 [7.92]	1.75 [44.45]	1.13 [28.7]	0.196 [4.98]	0.265 [6.73]
Ø 76 mm	CMS22	0.562 [14.27]	0.312 [7.92]	1.75 [44.45]	1.254 [31.85]	0.196 [4.98]	0.265 [6.73]
Ø 90 mm							

MOUNTING ACCESSORIES

CLAMPS FOR ST TYPES

To facilitate vertical mounting, a series of rigid clamps is available. These are made of zinc plated steel, chromium (III) passivated, or stainless steel (Ø D = 76 mm).

The clamps have either two or three mounting lugs, may be easily slipped over the capacitor and then clamped with a nut and bolt. Five types of clamps are available, one for each case diameter.

They are delivered without nuts or bolts.

To avoid damaging the insulation sleeve, do not overtighten the clamp screw.



RoHS
COMPLIANT

DIMENSIONS in millimeters **AND AVAILABLE FORMS**

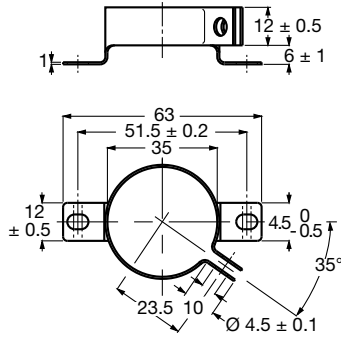


Fig. 1 - Dimensional outline of clamp for case Ø D = 35 mm

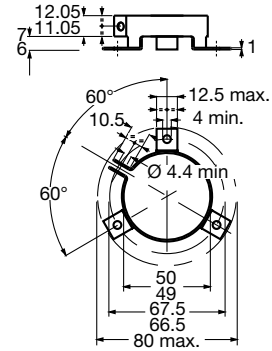


Fig. 2 - Dimensional outline of clamp for case Ø D = 50 mm

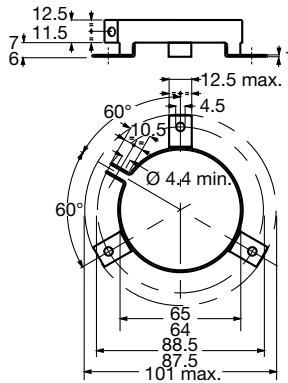


Fig. 3 - Dimensional outline of clamp for case Ø D = 65 mm

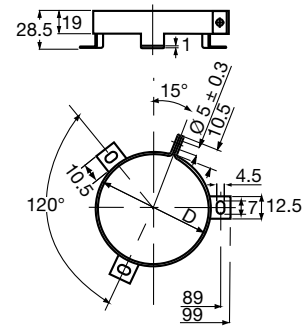


Fig. 4 - Dimensional outline of clamp for case Ø D = 76 mm

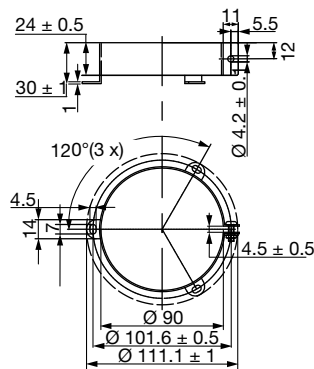


Fig. 5 - Dimensional outline of clamp for case Ø D = 90 mm

Table 1

MOUNTING CLAMPS FOR SCREW TERMINALS	
CASE DIAMETER	ORDERING CODE
35	MAL804324031E3
50	MAL804324051E3
65	MAL804324061E3
76	MAL804323321E3
90	MAL804324921E3

NUTS AND WASHERS FOR STB-VERSIONS

When mounting with the bolt, which is an integral part of the case, standard metal M8 and M12 nuts and washers may be used; the maximum permissible torque is 4 Nm for M8 nuts and 10 Nm for M12 nuts.

If insulated mounting is required, synthetic nuts and rubber washers are available; for these nuts the maximum permissible torque is 2 Nm (M8) and 4 Nm (M12).

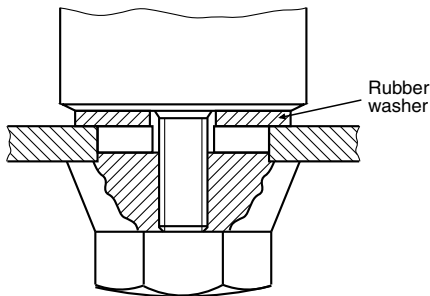
DIMENSIONS in millimeters AND AVAILABLE FORMS


Fig. 6 - Insulated mounting

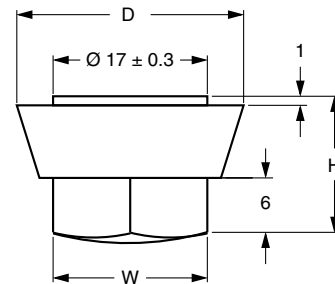


Fig. 7 - Synthetic cap nut; see Table 2 for dimensions D, H and W

Table 2

SYNTHETIC CAP NUTS						
CASE DIAMETER (mm)	THREAD	D (mm)	H (mm)	W ⁽¹⁾ (mm)	MIN. THREADED DEPTH (mm)	ORDERING CODE
35	M8	25	15	17	11.5	MAL804305561E3
≥ 50	M12	30	20	19	15.5	MAL804305571E3

Note

⁽¹⁾ Dimension W is measured across flats.

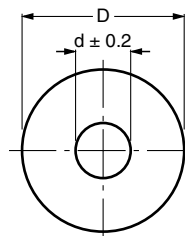


Fig. 8 - Rubber washer; thickness 2 mm

RUBBER WASHERS		
D (mm)	d (mm)	ORDERING CODE
34	8.4	MAL804305591E3
49	13.0	MAL804305531E3
64	13.0	MAL804305521E3
74	13.0	MAL804313001E3
88	13.0	MAL804329961E3

CLAMPS FOR SL-VERSIONS, $\varnothing D = 25 \text{ mm}, 30 \text{ mm}, 35 \text{ mm}, \text{ and } 40 \text{ mm}$

To facilitate vertical mounting, a series of rigid clamps made of zinc plated steel is available. These are made of zinc plated steel, chromium (III) passivated.

The clamps have two mounting lugs, may be easily slipped over the capacitor and then clamped with a nut and bolt. Four types of clamps are available, one for each case diameter.

They are delivered without nuts or bolts.

To avoid damaging the insulation sleeve, do not overtighten the clamp screw.



RoHS
COMPLIANT

DIMENSIONS in millimeters

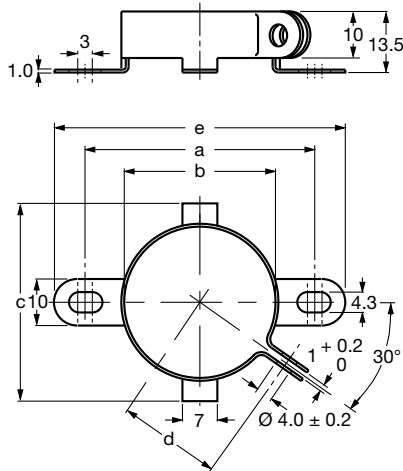


Fig. 9 - Dimensional outline of clamp for case $\varnothing D = 25 \text{ mm}, 30 \text{ mm}$ and 40 mm

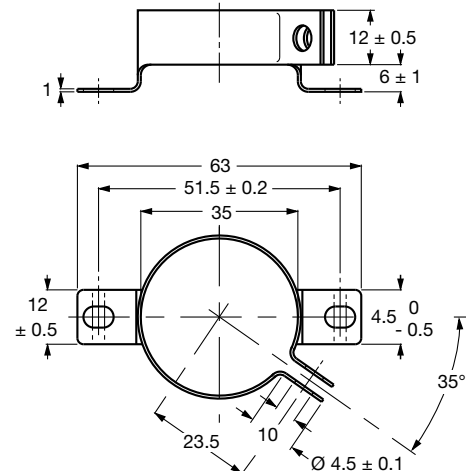


Fig. 10 - Dimensional outline of clamp for case $\varnothing D = 35 \text{ mm}$

Table 3

MOUNTING CLAMPS FOR SOLDER LUGS						
CASE DIAMETER (mm)	a (mm)	b (mm)	c (mm)	d (mm)	e (mm)	ORDERING CODE
25	41.5 ± 0.2	25	35	18.5	56	MAL804324011E3
30	46.5 ± 0.2	30	40	21	61	MAL804324021E3
35	51.5 ± 0.2	35	-	23.5	63	MAL804324031E3
40	56.5 ± 0.2	40	50	26	71	MAL804324041E3



Компания «ЭлектроПласт» предлагает заключение долгосрочных отношений при поставках импортных электронных компонентов на взаимовыгодных условиях!

Наши преимущества:

- Оперативные поставки широкого спектра электронных компонентов отечественного и импортного производства напрямую от производителей и с крупнейших мировых складов;
- Поставка более 17-ти миллионов наименований электронных компонентов;
- Поставка сложных, дефицитных, либо снятых с производства позиций;
- Оперативные сроки поставки под заказ (от 5 рабочих дней);
- Экспресс доставка в любую точку России;
- Техническая поддержка проекта, помощь в подборе аналогов, поставка прототипов;
- Система менеджмента качества сертифицирована по Международному стандарту ISO 9001;
- Лицензия ФСБ на осуществление работ с использованием сведений, составляющих государственную тайну;
- Поставка специализированных компонентов (Xilinx, Altera, Analog Devices, Intersil, Interpoint, Microsemi, Aeroflex, Peregrine, Syfer, Eurofarad, Texas Instrument, Miteq, Cobham, E2V, MA-COM, Hittite, Mini-Circuits, General Dynamics и др.);

Помимо этого, одним из направлений компании «ЭлектроПласт» является направление «Источники питания». Мы предлагаем Вам помощь Конструкторского отдела:

- Подбор оптимального решения, техническое обоснование при выборе компонента;
- Подбор аналогов;
- Консультации по применению компонента;
- Поставка образцов и прототипов;
- Техническая поддержка проекта;
- Защита от снятия компонента с производства.



Как с нами связаться

Телефон: 8 (812) 309 58 32 (многоканальный)

Факс: 8 (812) 320-02-42

Электронная почта: org@eplast1.ru

Адрес: 198099, г. Санкт-Петербург, ул. Калинина, дом 2, корпус 4, литера А.