

Wide Band GaAs MMIC Amplifier 0.2 - 3.0 GHz

Rev. V4

Features

- High Gain: 19 dB Typical
- Output Power: +14 dBm Typical
- Noise Figure: 3.7 dB Typical
- RoHS* Compliant

Description

M/A-COM's MAAM02350 is a wide band, MMIC amplifier. It includes two integrated gain stages and employs resistive feedback to obtain flat gain and a good, 50 ohm input, and output impedance match over a very wide bandwidth. The MAAM02350 operates from a single +6 V supply. It is fully monolithic.

The MAAM02350 functions well as a generic IF, driver or buffer amplifier where high gain, low noise figure, excellent linearity and low power consumption are important. Because of its wide bandwidth, the MAAM02350 can be used in numerous commercial and government system applications, such as wireless communications, EW and radar.

The MAAM02350 is manufactured in-house using a reliable, 0.5-micron, GaAs MESFET process. This product is 100% RF tested to ensure compliance to performance specifications.

Absolute Maximum Ratings ^{1,2}

Parameter	Absolute Maximum
V _{DD}	+7 V
Input Power	+20 dBm
Channel Temperature ³	+150°C
Operating Temperature	-55°C to +100°C
Storage Temperature	-65°C to +150°C

1. Exceeding any one or combination of these limits may cause permanent damage to this device.
2. M/A-COM does not recommend sustained operation near these survivability limits.
3. Typical thermal resistance (θ_{jc}) = +80°C/W.

Pad Layout

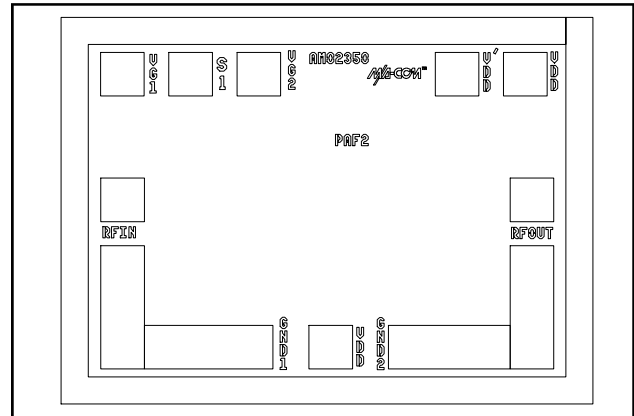

Die Size—Inches (mm)

0.044 x 0.032 x 0.004 (1.140 x 0.820 x 0.102)

Outline Drawing

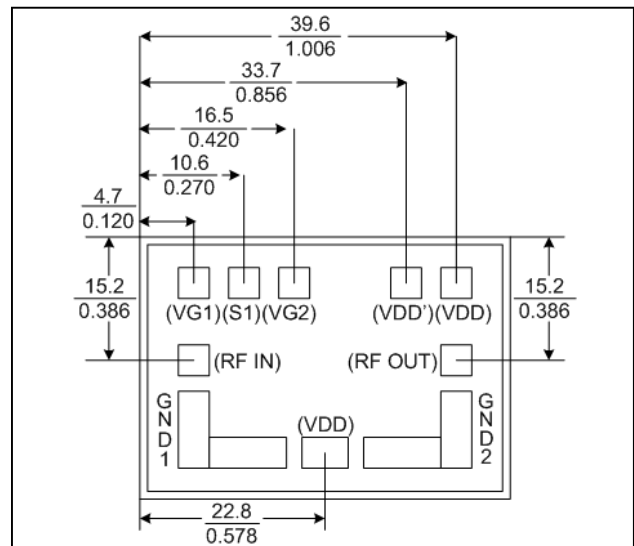

Ordering Information ^{4,5}

Part Number	Package
MAAM02350	DIE

4. Reference Application Note M538 for lead-free solder reflow recommendations.
5. Die quantity varies.

* Restrictions on Hazardous Substances, European Union Directive 2002/95/EC.

ADVANCED: Data Sheets contain information regarding a product M/A-COM Technology Solutions is considering for development. Performance is based on target specifications, simulated results, and/or prototype measurements. Commitment to develop is not guaranteed.

PRELIMINARY: Data Sheets contain information regarding a product M/A-COM Technology Solutions has under development. Performance is based on engineering tests. Specifications are typical. Mechanical outline has been fixed. Engineering samples and/or test data may be available. Commitment to produce in volume is not guaranteed.

- **North America** Tel: 800.366.2266 / Fax: 978.366.2266
- **Europe** Tel: 44.1908.574.200 / Fax: 44.1908.574.300
- **Asia/Pacific** Tel: 81.44.844.8296 / Fax: 81.44.844.8298

Visit www.macomtech.com for additional data sheets and product information.

M/A-COM Technology Solutions Inc. and its affiliates reserve the right to make changes to the product(s) or information contained herein without notice.

Wide Band GaAs MMIC Amplifier 0.2 - 3.0 GHz

Rev. V4

Electrical Specifications: $T_A = 25^\circ\text{C}$, $V_{DD} = +6\text{ V}$, $Z_0 = 50\ \Omega$

Parameter	Test Conditions	Units	Min.	Typ.	Max.
Gain	0.2 - 3.0 GHz, $P_{IN} = -30\text{ dBm}$	dB	17	19	—
Gain Flatness	0.2 - 3.0 GHz, $P_{IN} = -30\text{ dBm}$	dB	—	± 0.5	—
Noise Figure	0.2 - 3.0 GHz	dB	—	3.7	4.1
Input VSWR	0.2 - 3.0 GHz, $P_{IN} = -30\text{ dBm}$	Ratio	—	1.8:1	—
Output VSWR	0.2 - 3.0 GHz, $P_{IN} = -30\text{ dBm}$	Ratio	—	1.5:1	—
Output 1 dB Compression	0.2 - 3.0 GHz	dBm	—	+14	—
OIP3	0.2 - 3.0 GHz, $P_{IN} = -30\text{ dBm}$	dBm	—	24	—
Reverse Isolation	0.2 - 3.0 GHz, $P_{IN} = -30\text{ dBm}$	dB	—	35	—
Bias Current	—	mA	—	65	100

Schematic

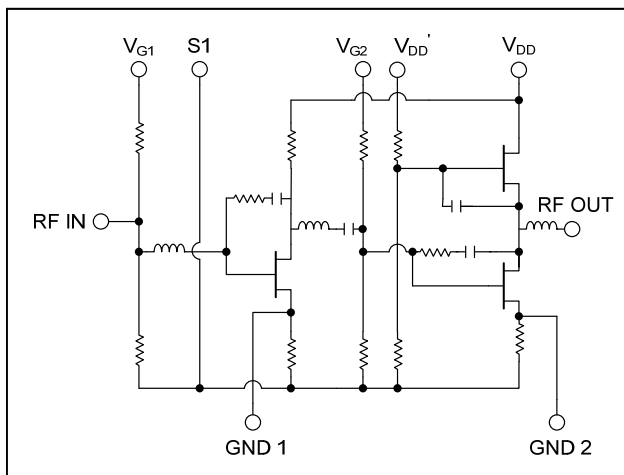

Typical Bias Configuration

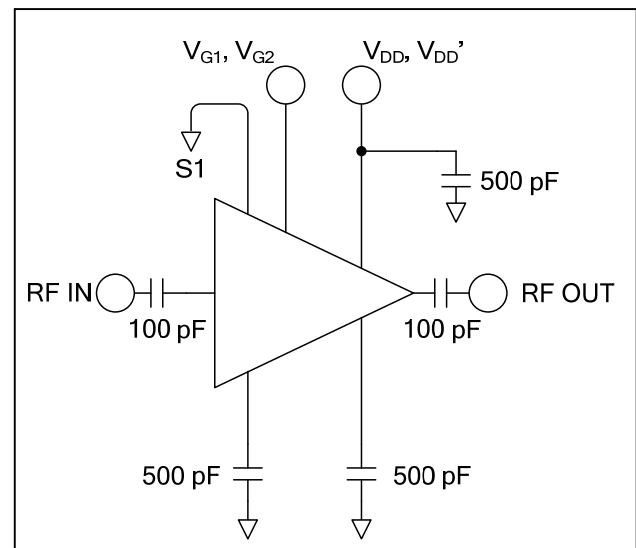

Handling Procedures

Please observe the following precautions to avoid damage:

Static Sensitivity

Gallium Arsenide Integrated Circuits are sensitive to electrostatic discharge (ESD) and can be damaged by static electricity. Proper ESD control techniques should be used when handling these devices.

- Self-bias operation is obtained by connecting +6 volts to both V_{DD} and V_{DD}' pads, grounding pad S1, and connecting pads GND1 and GND2 to separate bypass 500 pF MOS capacitors.

Typical Performance @ +25°C

Gain

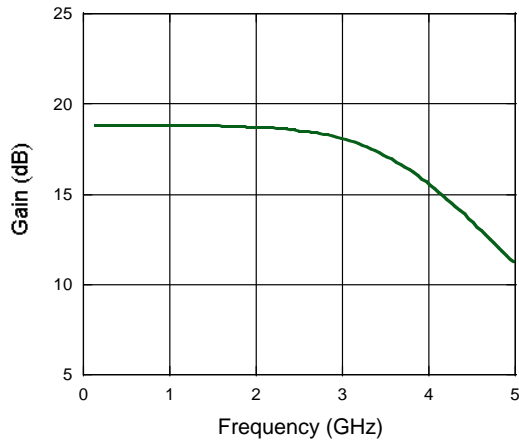

VSWR

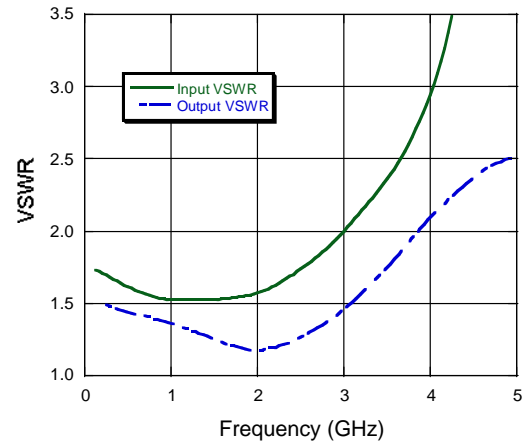

Noise Figure

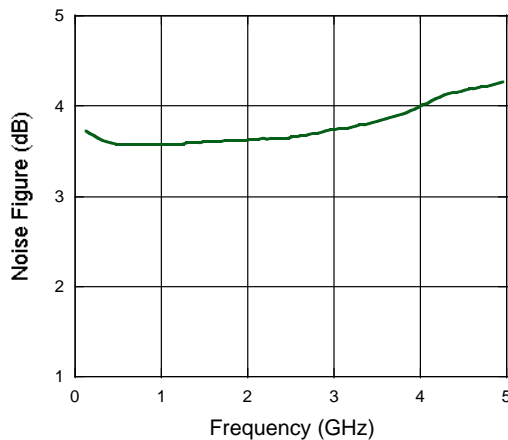

Handling

Permanent damage to the MAAM02350 may occur if the following precautions are not adhered to:

- A. Cleanliness - The MAAM02350 should be handled in a clean environment. Do not attempt to clean assembly after the MAAM02350 is installed.
- B. Static Sensitivity - All die handling equipment and personnel should comply with DOD-STD-1686 Class 1.
- C. Transients - Avoid instrument and power supply transients while bias is connected to the MAAM02350. Use shielded signal and bias cables to minimize inductive pick-up.
- D. General Handling - DO NOT touch the surface of the die. It is recommended that the MAAM02350 die be handled along the long side with a sharp pair of tweezers.

Mounting

The MAAM02350 is back-metallized with Pd/Ni/Au (100/1,000/30,000Å) metallization. It can be die-mounted using Au/Sn eutectic performs or a thermally and electrically conductive epoxy. The attachment surface should be clean and flat.

Eutectic Die Attach:

- A. An 80/20 Au/Sn perform is recommended with a work surface temperature of approximately 225°C and a tool temperature of 265°C. When hot 95/5 nitrogen/hydrogen gas is applied, solder temperature should be approximately 290°C.
- B. DO NOT expose the MAAM02350 to a temperature greater than 320°C for more than 20 seconds. No more than 3 seconds of scrubbing should be required for attachment.

Epoxy Die Attach:

- A. Apply a minimum amount of epoxy and place the MAAM02350 into position. A thin epoxy fillet should be visible around the perimeter of the die.
- B. Cure epoxy per manufacturer's recommended schedule.

Bonding

- A. Ball or wedge bond with 1.0 mil diameter gold wire or 3.0 mil x 0.5 mil ribbon. Thermosonic bonding with a nominal stage temperature of 150°C and a ball bonding force of 40 to 50 grams or wedge bonding force of 18 to 22 grams is recommended. Ultrasonic energy and time should be adjusted to the minimum levels necessary to achieve reliable bonds.
- B. Bonds should be started on the die and terminated on the package. RF bonds should be as short as possible; at least three and no more than four bond wires from ground pads to package are recommended.
- C. Bonding pads are 4.0 x 4.0 mils.



Компания «ЭлектроПласт» предлагает заключение долгосрочных отношений при поставках импортных электронных компонентов на взаимовыгодных условиях!

Наши преимущества:

- Оперативные поставки широкого спектра электронных компонентов отечественного и импортного производства напрямую от производителей и с крупнейших мировых складов;
- Поставка более 17-ти миллионов наименований электронных компонентов;
- Поставка сложных, дефицитных, либо снятых с производства позиций;
- Оперативные сроки поставки под заказ (от 5 рабочих дней);
- Экспресс доставка в любую точку России;
- Техническая поддержка проекта, помощь в подборе аналогов, поставка прототипов;
- Система менеджмента качества сертифицирована по Международному стандарту ISO 9001;
- Лицензия ФСБ на осуществление работ с использованием сведений, составляющих государственную тайну;
- Поставка специализированных компонентов (Xilinx, Altera, Analog Devices, Intersil, Interpoint, Microsemi, Aeroflex, Peregrine, Syfer, Eurofarad, Texas Instrument, Miteq, Cobham, E2V, MA-COM, Hittite, Mini-Circuits, General Dynamics и др.);

Помимо этого, одним из направлений компании «ЭлектроПласт» является направление «Источники питания». Мы предлагаем Вам помощь Конструкторского отдела:

- Подбор оптимального решения, техническое обоснование при выборе компонента;
- Подбор аналогов;
- Консультации по применению компонента;
- Поставка образцов и прототипов;
- Техническая поддержка проекта;
- Защита от снятия компонента с производства.



Как с нами связаться

Телефон: 8 (812) 309 58 32 (многоканальный)

Факс: 8 (812) 320-02-42

Электронная почта: org@eplast1.ru

Адрес: 198099, г. Санкт-Петербург, ул. Калинина, дом 2, корпус 4, литера А.