

## Tiny Serial Digital Thermal Sensor

### Features

- Digital Temperature Sensing in SOT-23-5 or TO-220 Packages
- Outputs Temperature as an 8-Bit Digital Word
- Simple SMBus/I<sup>2</sup>C™ Serial Port Interface
- Solid-State Temperature Sensing:
  - ±2°C (max.) Accuracy from +25°C to +85°C
  - ±3°C (max.) Accuracy from 0°C to +125°C
- Supply Voltage of 2.7V to 5.5V
- Low Power:
  - 200 µA (typ.) Operating Current
  - 5 µA (typ.) Standby Mode Current

### Applications

- Thermal Protection for Hard Disk Drives and other PC Peripherals
- PC Card Devices for Notebook Computers
- Low Cost Thermostat Controls
- Power Supplies
- Thermistor Replacement

### Package Types

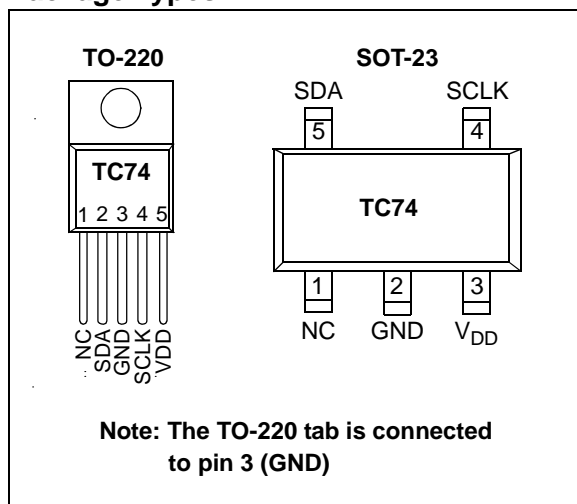

### General Description

The TC74 is a serially accessible, digital temperature sensor particularly suited for low cost and small form-factor applications. Temperature data is converted from the onboard thermal sensing element and made available as an 8-bit digital word.

Communication with the TC74 is accomplished via a 2-wire SMBus/I<sup>2</sup>C compatible serial port. This bus also can be used to implement multi-drop/multi-zone monitoring. The SHDN bit in the CONFIG register can be used to activate the low power Standby mode.

Temperature resolution is 1°C. Conversion rate is a nominal 8 samples/sec. During normal operation, the quiescent current is 200 µA (typ). During standby operation, the quiescent current is 5 µA (typ).

Small size, low installed cost and ease of use make the TC74 an ideal choice for implementing thermal management in a variety of systems.

### Functional Block Diagram

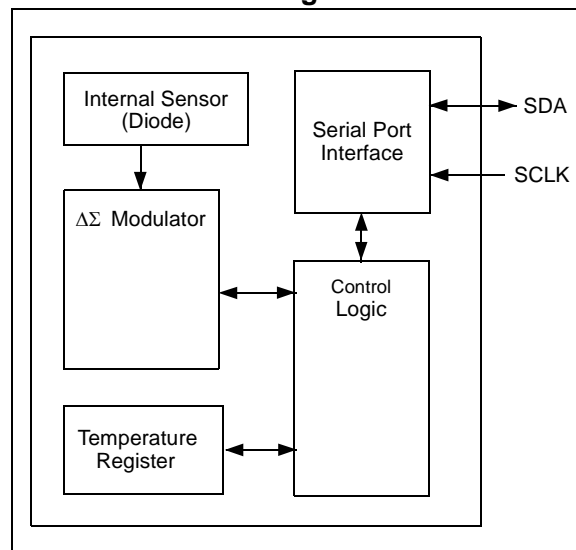

# TC74

## 1.0 ELECTRICAL CHARACTERISTICS

### 1.1 Absolute Maximum Ratings†

Supply Voltage ( $V_{DD}$ ) .....	+6V
Voltage On Any Pin .....	(GND – 0.3V) to ( $V_{DD}$ + 0.3V)
Current On Any Pin .....	±50 mA
Operating Temperature ( $T_A$ ) .....	-40°C ≤ $T_A$ ≤ +125°C
Storage Temperature ( $T_{STG}$ ) .....	-65°C to +150°C
Junction Temperature ( $T_J$ ) .....	+150°C

† **Notice:** Stresses above those listed under "Maximum Ratings" may cause permanent damage to the device. This is a stress rating only and functional operation of the device at those or any other conditions above those indicated in the operation listings of this specification is not implied. Exposure to maximum rating conditions for extended periods may affect device reliability.

## DC CHARACTERISTICS

Electrical Specifications: Unless otherwise noted, $V_{DD}$ = 3.3V for TC74AX-3.3VXX and $V_{DD}$ = 5.0V for TC74AX-5.0VXX, -40°C ≤ $T_A$ ≤ 125°C. <b>Note 5</b>						
Parameters	Sym	Min	Typ	Max	Units	Conditions
<b>Power Supply</b>						
Power-on Reset Threshold	$V_{POR}$	1.2	—	2.2	V	$V_{DD}$ Falling Edge or Rising Edge
Supply Voltage	$V_{DD}$	2.7	—	5.5	V	<b>Note 5</b>
Operating Current	$I_{DD}$	—	200	350	μA	$V_{DD}$ = 5.5V, <b>Note 1</b>
Standby Supply Current	$I_{DD-STANDBY}$	—	5.0	10	μA	$V_{DD}$ = 3.3V Serial Port Inactive, <b>Note 4</b>
<b>Temperature-to-Bits Converter</b>						
Temperature Accuracy	$T_{ERR}$	-2.0 -3.0 —	— — ±2.0	+2.0 +3.0 —	°C	+25°C < $T_A$ < +85°C 0°C < $T_A$ < +125°C -40°C < $T_A$ < 0°C
Conversion Rate	CR	4	8	—	SPS	<b>Note 2</b>
<b>Serial Port Interface</b>						
Logic Input High	$V_{IH}$	0.8 x $V_{DD}$	—	—	V	
Logic Input Low	$V_{IL}$	—	—	0.2 x $V_{DD}$	V	
SDA Output Low	$V_{OL}$	—	—	0.4 0.6	V	$I_{OL}$ = 3 mA $I_{OL}$ = 6 mA, <b>Note 3</b>
Input Capacitance SDA, SCLK	$C_{IN}$	—	5.0	—	pF	
I/O Leakage	$I_{LEAK}$	-1.0	0.1	1.0	μA	
<b>Serial Port AC Timing (<math>C_{LOAD}</math> = 80 pF)</b>						
SMBus/I <sup>2</sup> C Clock Frequency	$f_{SMB}$	10	—	100	kHz	
Low Clock Period	$t_{LOW}$	4.7	—	—	μsec	10% to 10%
High Clock Period	$t_{HIGH}$	4.0	—	—	μsec	90% to 90%
SMBus/I <sup>2</sup> C Rise Time	$t_R$	—	—	1000	nsec	10% to 90%
SMBus/I <sup>2</sup> C Fall Time	$t_F$	—	—	300	nsec	90% to 10%

- Note 1:** Operating current is an average value integrated over multiple conversion cycles. Transient current may exceed this specification.
- 2:** Maximum ensured conversion time after Power-on Reset (POR to DATA\_RDY) is 250 msec.
- 3:** Output current should be minimized for best temperature accuracy. Power dissipation within the TC74 will cause self-heating and temperature drift error.
- 4:** SDA and SCLK must be connected to  $V_{DD}$  or GND.
- 5:**  $V_{DD}$  = 3.3V for TC74AX -3.3 VXX.  $V_{DD}$  = 5.0V for TC74AX -5.0 VXX. All part types of the TC74 will operate properly over the wider power supply range of 2.7V to 5.5V. Each part type is tested and specified for rated accuracy at its nominal supply voltage. As  $V_{DD}$  varies from the nominal value, accuracy will degrade 1°C/V of  $V_{DD}$  change.

## DC CHARACTERISTICS (CONTINUED)

Electrical Specifications: Unless otherwise noted, $V_{DD} = 3.3V$ for TC74AX-3.3VXX and $V_{DD} = 5.0V$ for TC74AX-5.0VXX, $-40^{\circ}C \leq T_A \leq 125^{\circ}C$ . <b>Note 5</b>						
Parameters	Sym	Min	Typ	Max	Units	Conditions
START Condition Setup Time (for repeated START Condition)	$t_{SU(START)}$	4.0	—	—	$\mu\text{sec}$	90% SCLK to 10% SDA
START Condition Hold Time	$t_{H(START)}$	4.0	—	—	$\mu\text{sec}$	
Data In Setup Time	$t_{SU-DATA}$	1000	—	—	nsec	
Data In Hold Time	$t_{H-DAT}$	1250	—	—	nsec	
STOP Condition Setup Time	$t_{SU(STOP)}$	4.0	—	—	$\mu\text{sec}$	
Bus Free Time Prior to New Transition	$t_{IDLE}$	4.7	—	—	$\mu\text{sec}$	
Power-on Reset Delay	$t_{POR}$	—	500	—	$\mu\text{sec}$	$V_{DD} \geq V_{POR}$ (Rising Edge)

- Note 1:** Operating current is an average value integrated over multiple conversion cycles. Transient current may exceed this specification.
- 2:** Maximum ensured conversion time after Power-on Reset (POR to DATA\_RDY) is 250 msec.
- 3:** Output current should be minimized for best temperature accuracy. Power dissipation within the TC74 will cause self-heating and temperature drift error.
- 4:** SDA and SCLK must be connected to  $V_{DD}$  or GND.
- 5:**  $V_{DD} = 3.3V$  for TC74AX -3.3 VXX.  $V_{DD} = 5.0V$  for TC74AX -5.0 VXX. All part types of the TC74 will operate properly over the wider power supply range of 2.7V to 5.5V. Each part type is tested and specified for rated accuracy at its nominal supply voltage. As  $V_{DD}$  varies from the nominal value, accuracy will degrade  $1^{\circ}C/V$  of  $V_{DD}$  change.

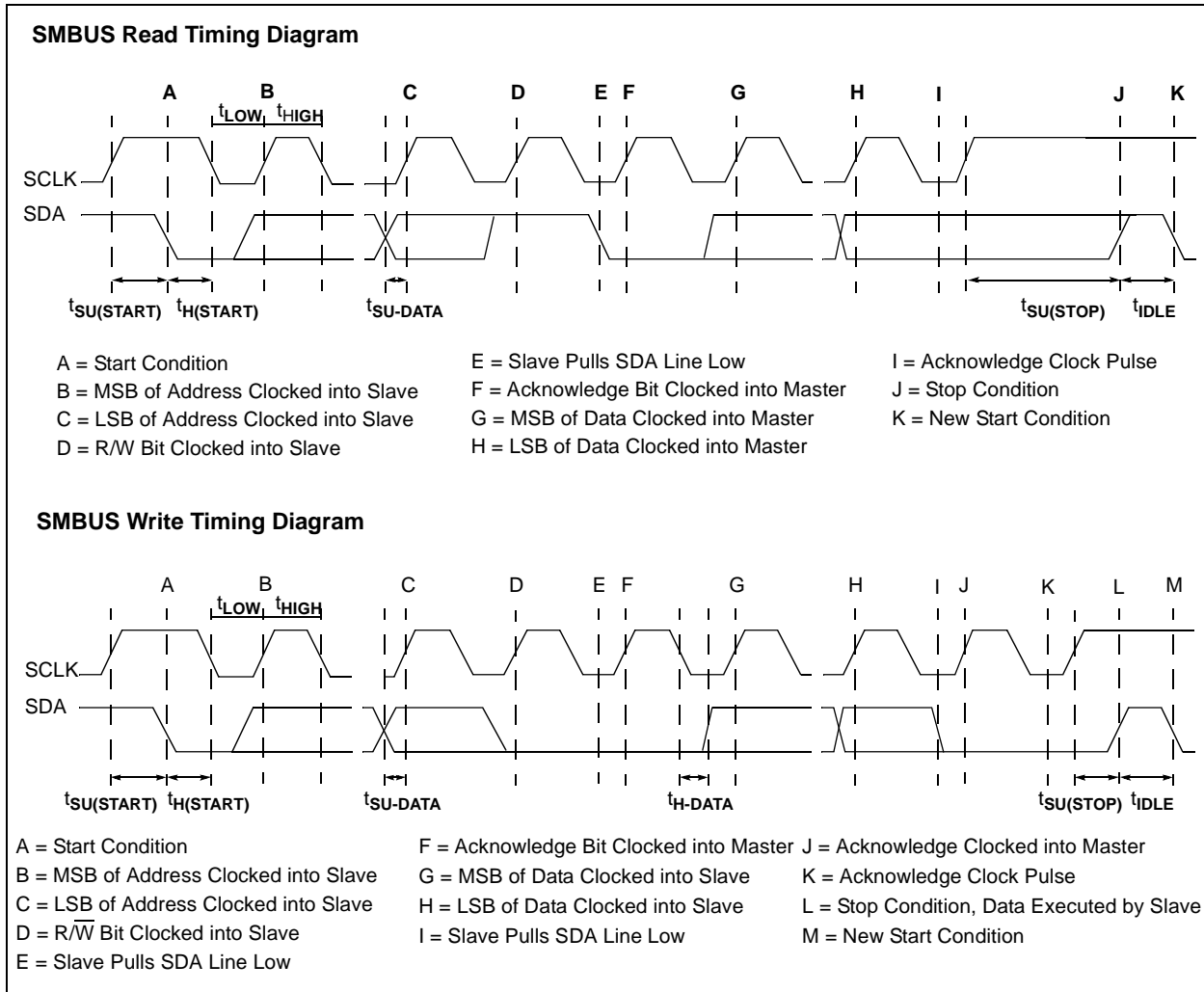

**FIGURE 1-1:** Timing Diagrams.

## 2.0 PIN DESCRIPTIONS

The descriptions of the pins are listed in Table 2-1.

**TABLE 2-1: PIN FUNCTION TABLE**

Pin No. (5-Pin SOT-23)	Pin No. (5-Pin TO-220)	Symbol	Type	Description
1	1	NC	None	No Internal Connection
2	3	GND	Power	System Ground
3	5	V <sub>DD</sub>	Power	Power Supply Input
4	4	SCLK	Input	SMBus/I <sup>2</sup> C Serial Clock
5	2	SDA	Bidirectional	SMBus/I <sup>2</sup> C Serial Data

### 2.1 Ground (GND)

Input. Ground return for all TC74 functions.

### 2.2 Power Supply Input (V<sub>DD</sub>)

Power supply input. See Electrical Specifications.

### 2.3 SMBus/I<sup>2</sup>C Serial Clock (SCLK)

Input. SMBus/I<sup>2</sup>C serial clock. Clocks data into and out of the TC74. See System Management Bus Specification, Rev. 1.0, for timing diagrams.

### 2.4 Serial Data (SDA)

Bidirectional. Serial data is transferred on the SMBus/I<sup>2</sup>C in both directions using this pin. See System Management Bus Specification, Rev. 1.0 for timing diagrams.

## 3.0 DETAILED DESCRIPTION

### 3.1 Functional Description

The TC74 acquires and converts temperature information from its onboard solid-state sensor with a resolution of  $\pm 1^{\circ}\text{C}$ . It stores the data in an internal register which is then read through the serial port. The system interface is a slave SMBus/I<sup>2</sup>C port, through which temperature data can be read at any time. Eight SMBus/I<sup>2</sup>C addresses are programmable for the TC74, which allows for a multi-sensor configuration. Also, there is low power Standby mode when temperature acquisition is suspended.

#### 3.1.1 STANDBY MODE

The host is allowed, by the TC74, to put it into a low power ( $I_{DD} = 5 \mu\text{A}$ , typical) Standby mode. In this mode, the A/D converter is halted and the temperature data registers are frozen. The SMBus/I<sup>2</sup>C port, though, operates normally. Standby mode is enabled by setting the SHDN bit in the CONFIG register. Table 3-1 summarizes this operation.

**TABLE 3-1: STANDBY MODE OPERATION**

SHDN Bit	Operating Mode
0	Normal
1	Standby

#### 3.1.2 SMBUS/I<sup>2</sup>C SLAVE ADDRESS

The TC74 is internally programmed to have a default SMBus/I<sup>2</sup>C address value of 1001 101b. Seven other addresses are available by custom order (contact Microchip Technology Inc).

### 3.2 Serial Port Operation

The Serial Clock input (SCLK) and bidirectional data port (SDA) form a 2-wire bidirectional serial port for programming and interrogating the TC74. The conventions used in this bus architecture are listed in Table 3-2.

**TABLE 3-2: SERIAL BUS CONVENTIONS**

Term	Explanation
Transmitter	The device sending data to the bus.
Receiver	The device receiving data from the bus.
Master	The device which controls the bus initiating transfers (START), generating the clock and terminating transfers (STOP).
Slave	The device addressed by the master.
START	A unique condition signaling the beginning of a transfer indicated by SDA falling (high-low) while SCLK is high.
STOP	A unique condition signaling the end of a transfer indicated by SDA rising (low-high) while SCLK is high.
ACK	A Receiver acknowledges the receipt of each byte with this unique condition. The Receiver drives SDA low during SCLK high of the ACK clock-pulse. The Master provides the clock pulse for the ACK cycle.
Busy	Communication is not possible because the bus is in use.
NOT Busy	When the bus is idle, both SDA and SCLK will remain high.
Data Valid	The state of SDA must remain stable during the high period of SCLK in order for a data bit to be considered valid. SDA only changes state while SCLK is low during normal data transfers (see START and STOP conditions).

All transfers take place under the control of a host, usually a CPU or microcontroller, acting as the Master. This host provides the clock signal for all transfers. The TC74 always operates as a Slave. The serial protocol is illustrated in Figure 3-1. All data transfers have two phases and all bytes are transferred MSB first. Accesses are initiated by a START condition, followed by a device address byte and one or more data bytes. The device address byte includes a Read/Write selection bit. Each access must be terminated by a STOP condition. A convention called "Acknowledge" (ACK) confirms receipt of each byte. Note that SDA can change only during periods when SCLK is low (SDA changes while SCLK is high are reserved for START and STOP conditions).

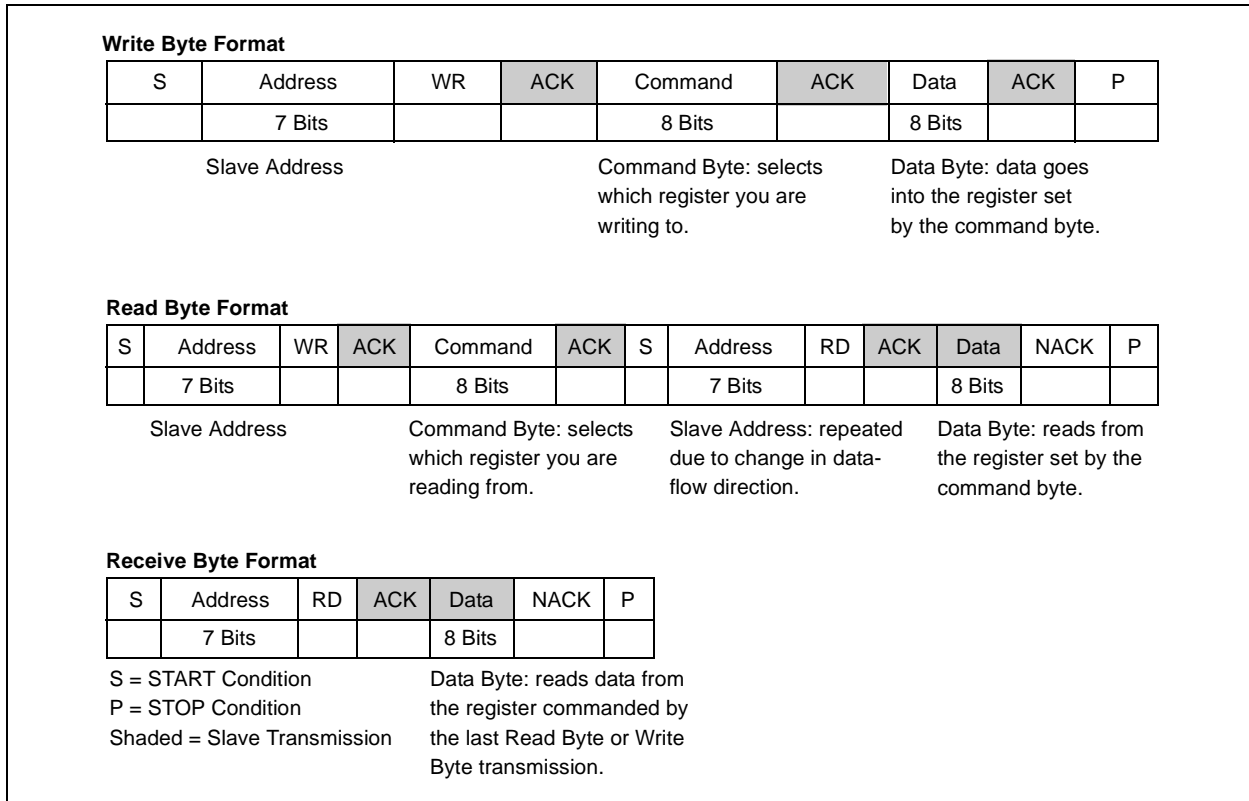

**FIGURE 3-1:** SMBus/I<sup>2</sup>C Protocols.

### 3.3 START Condition (S)

The TC74 continuously monitors the SDA and SCLK lines for a START condition (a high-to-low transition of SDA while SCLK is high) and will not respond until this condition is met.

### 3.4 Address Byte

Immediately following the START condition, the host must transmit the address byte to the TC74. The states of A2, A1 and A0 determine the SMBus/I<sup>2</sup>C address for the TC74. The 7-bit address transmitted in the serial bit stream must match for the TC74 to respond with an Acknowledge (indicating the TC74 is on the bus and ready to accept data). The 8-bit in the address byte is a Read/Write bit. This bit is a '1' for a read operation or '0' for a write operation. During the first phase of any transfer, this bit will be set = 0, indicating that the command byte is being written.

### 3.5 Acknowledge (ACK)

Acknowledge (ACK) provides a positive handshake between the host and the TC74. The host releases SDA after transmitting 8 bits. The host then generates a ninth clock cycle to allow the TC74 to pull the SDA line low. This action acknowledges that the TC74 successfully received the previous 8 bits of data or address.

### 3.6 Data Byte

After a successful ACK of the address byte, the host must transmit the data byte to be written, or clock-in the data to be read (see the appropriate timing diagrams). ACK will be generated upon a successful write of a data byte into the TC74.

### 3.7 STOP Condition (P)

Communications must be terminated by a STOP condition (a low-to-high transition of SDA while SCLK is high). The STOP condition must be communicated by the transmitter to the TC74. Refer to Figure 1-1, "Timing Diagrams", for serial bus timing.

## 4.0 REGISTER SET AND PROGRAMMER'S MODEL

**TABLE 4-1: COMMAND BYTE DESCRIPTION (SMBUS/I<sup>2</sup>C READ\_BYTE AND WRITE\_BYTE)**

Command	Code	Function
RTR	00h	Read Temperature (TEMP)
RWCR	01h	Read/Write Configuration (CONFIG)

**TABLE 4-2: CONFIGURATION REGISTER (CONFIG); 8 BITS, READ/WRITE)**

Bit	POR	Function	Type	Operation
D[7]	0	STANDBY Switch	Read/Write	1 = standby, 0 = normal
D[6]	0	Data Ready *	Read Only	1 = ready 0 = not ready
D[5]-D[0]	0	Reserved - Always returns zero when read	N/A	N/A

**Note 1:** \*DATA\_RDY bit RESET at power-up and SHDN enable.



**FIGURE 4-1:** DATA\_RDY, SHDN Operation Logic Diagram.

### 4.1 Temperature Register (TEMP), 8 Bits, READ ONLY

The binary value (2's complement format) in this register represents temperature of the onboard sensor following a conversion cycle. The registers are automatically updated in an alternating manner.

**TABLE 4-3: TEMPERATURE REGISTER (TEMP)**

D[7]	D[6]	D[5]	D[4]	D[3]	D[2]	D[1]	D[0]
MSB	X	X	X	X	X	X	LSB

In temperature data registers, each unit value represents one degree (Celsius). The value is in 2's complement binary format such that a reading of 0000 0000b corresponds to 0°C. Examples of this temperature to binary value relationship are shown in Table 4-4.

**TABLE 4-4: TEMPERATURE-TO-DIGITAL VALUE CONVERSION (TEMP)**

Actual Temperature	Registered Temperature	Binary Hex
+130.00°C	+127°C	0111 1111
+127.00°C	+127°C	0111 1111
+126.50°C	+126°C	0111 1110
+25.25°C	+25°C	0001 1001
+0.50°C	0°C	0000 0000
+0.25°C	0°C	0000 0000
0.00°C	0°C	0000 0000
-0.25°C	-1°C	1111 1111
-0.50°C	-1°C	1111 1111
-0.75°C	-1°C	1111 1111
-1.00°C	-1°C	1111 1111
-25.00°C	-25°C	1110 0111
-25.25°C	-26°C	1110 0110
-54.75°C	-55°C	1100 1001
-55.00°C	-55°C	1100 1001
-65.00°C	-65°C	1011 1111

### 4.2 Register Set Summary

The TC74 register set is summarized in Table 4-5. All registers are 8 bits wide.

**TABLE 4-5: TC74 REGISTER SET SUMMARY**

Name	Description	POR State	Read	Write
TEMP	Internal Sensor Temperature (2's Complement)	0000 0000b <sup>(1)</sup>	√	N/A
CONFIG	CONFIG Register	0000 0000b	√	√

**Note 1:** The TEMP register will be immediately updated by the A/D converter after the DATA\_RDY Bit goes high.



## 5.0 PACKAGING INFORMATION

### 5.1 SOT23A Package Marking Information



### SOT-23 Package Marking Codes

SOT-23 (V)	Address	Code	SOT-23 (V)	Address	Code
TC74A0-3.3VCT	1001 000	V0	TC74A0-5.0VCT	1001 000	U0
TC74A1-3.3VCT	1001 001	V1	TC74A1-5.0VCT	1001 001	U1
TC74A2-3.3VCT	1001 010	V2	TC74A2-5.0VCT	1001 010	U2
TC74A3-3.3VCT	1001 011	V3	TC74A3-5.0VCT	1001 011	U3
TC74A4-3.3VCT	1001 100	V4	TC74A4-5.0VCT	1001 100	U4
TC74A5-3.3VCT	1001 101*	V5	TC74A5-5.0VCT	1001 101*	U5
TC74A6-3.3VCT	1001 110	V6	TC74A6-5.0VCT	1001 110	U6
TC74A7-3.3VCT	1001 111	V7	TC74A7-5.0VCT	1001 111	U7

**Note:** \* Default Address

### TO-220 Package Marking Information



## 5.2 Taping Forms

Component Taping Orientation for 5-Pin SOT-23A (EIAJ SC-74A) Devices

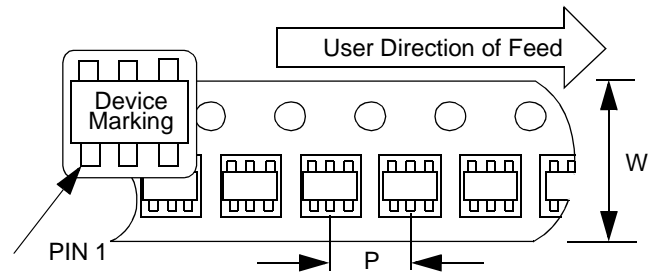

Standard Reel Component Orientation  
for TR Suffix Device  
(Mark Right Side Up)

Carrier Tape, Number of Components Per Reel and Reel Size:

Package	Carrier Width (W)	Pitch (P)	Part Per Full Reel	Reel Size
5-Pin SOT-23A	8 mm	4 mm	3000	7 in.

## 5.3 Package Dimensions

**Note:** For the most current package drawings, please see the Microchip Packaging Specification located at <http://www.microchip.com/packaging>

### SOT-23A-5

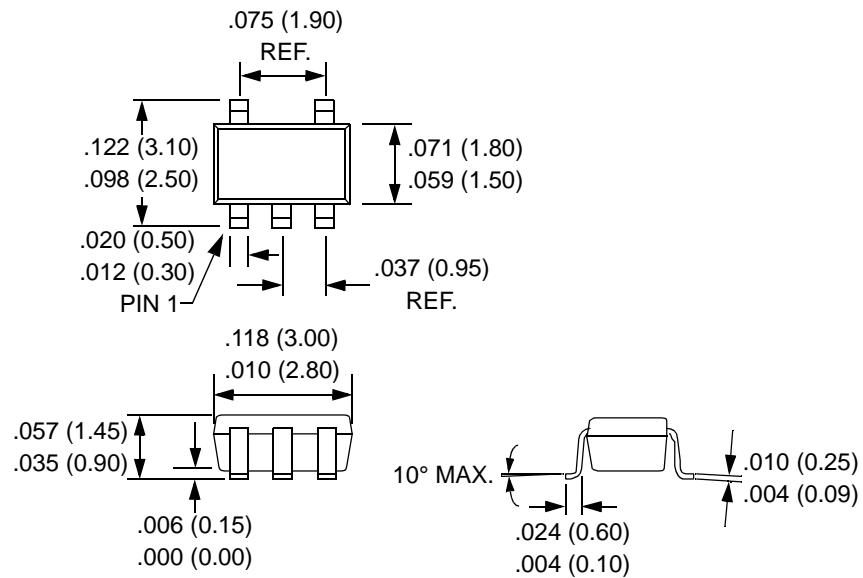

Dimensions: inches (mm)

**Note:** For the most current package drawings, please see the Microchip Packaging Specification located at <http://www.microchip.com/packaging>

## 5-Pin TO-220



Dimensions: inches (mm)

## 6.0 REVISION HISTORY

### Revision D (December 2012)

Added a note to each package outline drawing.

# TC74

---

---

NOTES:

## PRODUCT IDENTIFICATION SYSTEM

To order or obtain information, e.g., on pricing or delivery, refer to the factory or the listed sales office.

<u>PART NO.</u>	<u>XX</u>	<u>-XX</u>	<u>X</u>	<u>XX</u>	<b>Examples:</b>
Device	Address Options	Supply Voltage	Operating Temperature	Package	
Device:	TC74: Serial Digital Thermal Sensor				a) TC74A0-3.3VCTTR: SOT-23 Serial Digital Thermal Sensor
Address Options:	A0 = 1001 000				b) TC74A1-3.3VCTTR: SOT-23 Serial Digital Thermal Sensor
	A1 = 1001 001				c) TC74A2-3.3VCTTR: SOT-23 Serial Digital Thermal Sensor
	A2 = 1001 010				d) TC74A3-3.3VCTTR: SOT-23 Serial Digital Thermal Sensor
	A3 = 1001 011				e) TC74A4-3.3VCTTR: SOT-23 Serial Digital Thermal Sensor
	A4 = 1001 100				f) TC74A5-3.3VCTTR: SOT-23 Serial Digital Thermal Sensor *
	A5 = 1001 101 *				g) TC74A6-3.3VCTTR: SOT-23 Serial Digital Thermal Sensor
	A6 = 1001 110				h) TC74A7-3.3VCTTR: SOT-23 Serial Digital Thermal Sensor
	A7 = 1001 111				
	* Default Address				a) TC74A0-5.0VCTTR: SOT-23 Serial Digital Thermal Sensor
Supply Voltage:	3.3 = Accuracy optimized for 3.3V				b) TC74A1-5.0VCTTR: SOT-23 Serial Digital Thermal Sensor
	5.0 = Accuracy optimized for 5.0V				c) TC74A2-5.0VCTTR: SOT-23 Serial Digital Thermal Sensor
Operating Temperature:	V = -40°C ≤ T <sub>A</sub> ≤ +125°C				d) TC74A3-5.0VCTTR: SOT-23 Serial Digital Thermal Sensor
Package:	CTTR = SOT-23-5 (Tape and Reel only)				e) TC74A4-5.0VCTTR: SOT-23 Serial Digital Thermal Sensor
					f) TC74A5-5.0VCTTR: SOT-23 Serial Digital Thermal Sensor *
					g) TC74A6-5.0VCTTR: SOT-23 Serial Digital Thermal Sensor
					h) TC74A7-5.0VCTTR: SOT-23 Serial Digital Thermal Sensor
					* Default Address

<u>PART NO.</u>	<u>XX</u>	<u>-XX</u>	<u>X</u>	<u>XX</u>	<b>Examples:</b>
Device	Address Options	Supply Voltage	Operating Temperature	Package	
Device:	TC74: Serial Digital Thermal Sensor				a) TC74A0-3.3VAT: TO-220 Serial Digital Thermal Sensor
Address Options:	A0 = 1001 000				b) TC74A1-3.3VAT: TO-220 Serial Digital Thermal Sensor
	A1 = 1001 001				c) TC74A2-3.3VAT: TO-220 Serial Digital Thermal Sensor
	A2 = 1001 010				d) TC74A3-3.3VAT: TO-220 Serial Digital Thermal Sensor
	A3 = 1001 011				e) TC74A4-3.3VAT: TO-220 Serial Digital Thermal Sensor
	A4 = 1001 100				f) TC74A5-3.3VAT: TO-220 Serial Digital Thermal Sensor *
	A5 = 1001 101 *				g) TC74A6-3.3VAT: TO-220 Serial Digital Thermal Sensor
	A6 = 1001 110				h) TC74A7-3.3VAT: TO-220 Serial Digital Thermal Sensor
	A7 = 1001 111				
	* Default Address				a) TC74A0-5.0VAT: TO-220 Serial Digital Thermal Sensor
Output Voltage:	3.3 = Accuracy optimized for 3.3V				b) TC74A1-5.0VAT: TO-220 Serial Digital Thermal Sensor
	5.0 = Accuracy optimized for 5.0V				c) TC74A2-5.0VAT: TO-220 Serial Digital Thermal Sensor
Operating Temperature:	V = -40°C ≤ T <sub>A</sub> ≤ +125°C				d) TC74A3-5.0VAT: TO-220 Serial Digital Thermal Sensor
Package:	AT = TO-220-5				e) TC74A4-5.0VAT: TO-220 Serial Digital Thermal Sensor
					f) TC74A5-5.0VAT: TO-220 Serial Digital Thermal Sensor *
					g) TC74A6-5.0VAT: TO-220 Serial Digital Thermal Sensor
					h) TC74A7-5.0VAT: TO-220 Serial Digital Thermal Sensor
					* Default Address

### Sales and Support

#### Data Sheets

Products supported by a preliminary Data Sheet may have an errata sheet describing minor operational differences and recommended workarounds. To determine if an errata sheet exists for a particular device, please contact one of the following:

1. Your local Microchip sales office
2. The Microchip Worldwide Site ([www.microchip.com](http://www.microchip.com))

Please specify which device, revision of silicon and Data Sheet (include Literature #) you are using.

#### New Customer Notification System

Register on our web site ([www.microchip.com/cn](http://www.microchip.com/cn)) to receive the most current information on our products.

# TC74

---

NOTES:



---

**Note the following details of the code protection feature on Microchip devices:**

- Microchip products meet the specification contained in their particular Microchip Data Sheet.
- Microchip believes that its family of products is one of the most secure families of its kind on the market today, when used in the intended manner and under normal conditions.
- There are dishonest and possibly illegal methods used to breach the code protection feature. All of these methods, to our knowledge, require using the Microchip products in a manner outside the operating specifications contained in Microchip's Data Sheets. Most likely, the person doing so is engaged in theft of intellectual property.
- Microchip is willing to work with the customer who is concerned about the integrity of their code.
- Neither Microchip nor any other semiconductor manufacturer can guarantee the security of their code. Code protection does not mean that we are guaranteeing the product as “unbreakable.”

Code protection is constantly evolving. We at Microchip are committed to continuously improving the code protection features of our products. Attempts to break Microchip's code protection feature may be a violation of the Digital Millennium Copyright Act. If such acts allow unauthorized access to your software or other copyrighted work, you may have a right to sue for relief under that Act.

---

Information contained in this publication regarding device applications and the like is provided only for your convenience and may be superseded by updates. It is your responsibility to ensure that your application meets with your specifications. MICROCHIP MAKES NO REPRESENTATIONS OR WARRANTIES OF ANY KIND WHETHER EXPRESS OR IMPLIED, WRITTEN OR ORAL, STATUTORY OR OTHERWISE, RELATED TO THE INFORMATION, INCLUDING BUT NOT LIMITED TO ITS CONDITION, QUALITY, PERFORMANCE, MERCHANTABILITY OR FITNESS FOR PURPOSE. Microchip disclaims all liability arising from this information and its use. Use of Microchip devices in life support and/or safety applications is entirely at the buyer's risk, and the buyer agrees to defend, indemnify and hold harmless Microchip from any and all damages, claims, suits, or expenses resulting from such use. No licenses are conveyed, implicitly or otherwise, under any Microchip intellectual property rights.

#### **Trademarks**

The Microchip name and logo, the Microchip logo, dsPIC, FlashFlex, KEELOQ, KEELOQ logo, MPLAB, PIC, PICmicro, PICSTART, PIC<sup>32</sup> logo, rPIC, SST, SST Logo, SuperFlash and UNI/O are registered trademarks of Microchip Technology Incorporated in the U.S.A. and other countries.

FilterLab, Hampshire, HI-TECH C, Linear Active Thermistor, MTP, SEEVAL and The Embedded Control Solutions Company are registered trademarks of Microchip Technology Incorporated in the U.S.A.

Silicon Storage Technology is a registered trademark of Microchip Technology Inc. in other countries.

Analog-for-the-Digital Age, Application Maestro, BodyCom, chipKIT, chipKIT logo, CodeGuard, dsPICDEM, dsPICDEM.net, dsPICworks, dsSPEAK, ECAN, ECONOMONITOR, FanSense, HI-TIDE, In-Circuit Serial Programming, ICSP, Mindi, MiWi, MPASM, MPF, MPLAB Certified logo, MPLIB, MPLINK, mTouch, Omniclient Code Generation, PICC, PICC-18, PICDEM, PICDEM.net, PICkit, PICtail, REAL ICE, rLAB, Select Mode, SQI, Serial Quad I/O, Total Endurance, TSHARC, UniWinDriver, WiperLock, ZENA and Z-Scale are trademarks of Microchip Technology Incorporated in the U.S.A. and other countries.

SQTP is a service mark of Microchip Technology Incorporated in the U.S.A.

GestIC and ULPP are registered trademarks of Microchip Technology Germany II GmbH & Co. & KG, a subsidiary of Microchip Technology Inc., in other countries.

All other trademarks mentioned herein are property of their respective companies.

© 2001-2012, Microchip Technology Incorporated, Printed in the U.S.A., All Rights Reserved.

 Printed on recycled paper.

ISBN: 9781620768396

**QUALITY MANAGEMENT SYSTEM**  
**CERTIFIED BY DNV**  
**== ISO/TS 16949 ==**

*Microchip received ISO/TS-16949:2009 certification for its worldwide headquarters, design and wafer fabrication facilities in Chandler and Tempe, Arizona; Gresham, Oregon and design centers in California and India. The Company's quality system processes and procedures are for its PIC<sup>®</sup> MCUs and dsPIC<sup>®</sup> DSCs, KEELOQ<sup>®</sup> code hopping devices, Serial EEPROMs, microperipherals, nonvolatile memory and analog products. In addition, Microchip's quality system for the design and manufacture of development systems is ISO 9001:2000 certified.*



# MICROCHIP

## Worldwide Sales and Service

### AMERICAS

**Corporate Office**  
2355 West Chandler Blvd.  
Chandler, AZ 85224-6199  
Tel: 480-792-7200  
Fax: 480-792-7277  
Technical Support:  
<http://www.microchip.com/support>  
Web Address:  
[www.microchip.com](http://www.microchip.com)

**Atlanta**  
Duluth, GA  
Tel: 678-957-9614  
Fax: 678-957-1455

**Boston**  
Westborough, MA  
Tel: 774-760-0087  
Fax: 774-760-0088

**Chicago**  
Itasca, IL  
Tel: 630-285-0071  
Fax: 630-285-0075

**Cleveland**  
Independence, OH  
Tel: 216-447-0464  
Fax: 216-447-0643

**Dallas**  
Addison, TX  
Tel: 972-818-7423  
Fax: 972-818-2924

**Detroit**  
Farmington Hills, MI  
Tel: 248-538-2250  
Fax: 248-538-2260

**Indianapolis**  
Noblesville, IN  
Tel: 317-773-8323  
Fax: 317-773-5453

**Los Angeles**  
Mission Viejo, CA  
Tel: 949-462-9523  
Fax: 949-462-9608

**Santa Clara**  
Santa Clara, CA  
Tel: 408-961-6444  
Fax: 408-961-6445

**Toronto**  
Mississauga, Ontario,  
Canada  
Tel: 905-673-0699  
Fax: 905-673-6509

### ASIA/PACIFIC

**Asia Pacific Office**  
Suites 3707-14, 37th Floor  
Tower 6, The Gateway  
Harbour City, Kowloon  
Hong Kong  
Tel: 852-2401-1200  
Fax: 852-2401-3431

**Australia - Sydney**  
Tel: 61-2-9868-6733  
Fax: 61-2-9868-6755

**China - Beijing**  
Tel: 86-10-8569-7000  
Fax: 86-10-8528-2104

**China - Chengdu**  
Tel: 86-28-8665-5511  
Fax: 86-28-8665-7889

**China - Chongqing**  
Tel: 86-23-8980-9588  
Fax: 86-23-8980-9500

**China - Hangzhou**  
Tel: 86-571-2819-3187  
Fax: 86-571-2819-3189

**China - Hong Kong SAR**  
Tel: 852-2943-5100  
Fax: 852-2401-3431

**China - Nanjing**  
Tel: 86-25-8473-2460  
Fax: 86-25-8473-2470

**China - Qingdao**  
Tel: 86-532-8502-7355  
Fax: 86-532-8502-7205

**China - Shanghai**  
Tel: 86-21-5407-5533  
Fax: 86-21-5407-5066

**China - Shenyang**  
Tel: 86-24-2334-2829  
Fax: 86-24-2334-2393

**China - Shenzhen**  
Tel: 86-755-8864-2200  
Fax: 86-755-8203-1760

**China - Wuhan**  
Tel: 86-27-5980-5300  
Fax: 86-27-5980-5118

**China - Xian**  
Tel: 86-29-8833-7252  
Fax: 86-29-8833-7256

**China - Xiamen**  
Tel: 86-592-2388138  
Fax: 86-592-2388130

**China - Zhuhai**  
Tel: 86-756-3210040  
Fax: 86-756-3210049

### ASIA/PACIFIC

**India - Bangalore**  
Tel: 91-80-3090-4444  
Fax: 91-80-3090-4123

**India - New Delhi**  
Tel: 91-11-4160-8631  
Fax: 91-11-4160-8632

**India - Pune**  
Tel: 91-20-2566-1512  
Fax: 91-20-2566-1513

**Japan - Osaka**  
Tel: 81-6-6152-7160  
Fax: 81-6-6152-9310

**Japan - Tokyo**  
Tel: 81-3-6880-3770  
Fax: 81-3-6880-3771

**Korea - Daegu**  
Tel: 82-53-744-4301  
Fax: 82-53-744-4302

**Korea - Seoul**  
Tel: 82-2-554-7200  
Fax: 82-2-558-5932 or  
82-2-558-5934

**Malaysia - Kuala Lumpur**  
Tel: 60-3-6201-9857  
Fax: 60-3-6201-9859

**Malaysia - Penang**  
Tel: 60-4-227-8870  
Fax: 60-4-227-4068

**Philippines - Manila**  
Tel: 63-2-634-9065  
Fax: 63-2-634-9069

**Singapore**  
Tel: 65-6334-8870  
Fax: 65-6334-8850

**Taiwan - Hsin Chu**  
Tel: 886-3-5778-366  
Fax: 886-3-5770-955

**Taiwan - Kaohsiung**  
Tel: 886-7-213-7828  
Fax: 886-7-330-9305

**Taiwan - Taipei**  
Tel: 886-2-2508-8600  
Fax: 886-2-2508-0102

**Thailand - Bangkok**  
Tel: 66-2-694-1351  
Fax: 66-2-694-1350

### EUROPE

**Austria - Wels**  
Tel: 43-7242-2244-39  
Fax: 43-7242-2244-393

**Denmark - Copenhagen**  
Tel: 45-4450-2828  
Fax: 45-4485-2829

**France - Paris**  
Tel: 33-1-69-53-63-20  
Fax: 33-1-69-30-90-79

**Germany - Munich**  
Tel: 49-89-627-144-0  
Fax: 49-89-627-144-44

**Italy - Milan**  
Tel: 39-0331-742611  
Fax: 39-0331-466781

**Netherlands - Drunen**  
Tel: 31-416-690399  
Fax: 31-416-690340

**Spain - Madrid**  
Tel: 34-91-708-08-90  
Fax: 34-91-708-08-91

**UK - Wokingham**  
Tel: 44-118-921-5869  
Fax: 44-118-921-5820

11/29/12



Компания «ЭлектроПласт» предлагает заключение долгосрочных отношений при поставках импортных электронных компонентов на взаимовыгодных условиях!

Наши преимущества:

- Оперативные поставки широкого спектра электронных компонентов отечественного и импортного производства напрямую от производителей и с крупнейших мировых складов;
- Поставка более 17-ти миллионов наименований электронных компонентов;
- Поставка сложных, дефицитных, либо снятых с производства позиций;
- Оперативные сроки поставки под заказ (от 5 рабочих дней);
- Экспресс доставка в любую точку России;
- Техническая поддержка проекта, помощь в подборе аналогов, поставка прототипов;
- Система менеджмента качества сертифицирована по Международному стандарту ISO 9001;
- Лицензия ФСБ на осуществление работ с использованием сведений, составляющих государственную тайну;
- Поставка специализированных компонентов (Xilinx, Altera, Analog Devices, Intersil, Interpoint, Microsemi, Aeroflex, Peregrine, Syfer, Eurofarad, Texas Instrument, Miteq, Cobham, E2V, MA-COM, Hittite, Mini-Circuits, General Dynamics и др.);

Помимо этого, одним из направлений компании «ЭлектроПласт» является направление «Источники питания». Мы предлагаем Вам помощь Конструкторского отдела:

- Подбор оптимального решения, техническое обоснование при выборе компонента;
- Подбор аналогов;
- Консультации по применению компонента;
- Поставка образцов и прототипов;
- Техническая поддержка проекта;
- Защита от снятия компонента с производства.



#### Как с нами связаться

**Телефон:** 8 (812) 309 58 32 (многоканальный)

**Факс:** 8 (812) 320-02-42

**Электронная почта:** [org@eplast1.ru](mailto:org@eplast1.ru)

**Адрес:** 198099, г. Санкт-Петербург, ул. Калинина, дом 2, корпус 4, литера А.