

---

## Standard Product Offerings

The families of Secure RF devices in the tables below are available as standard products. Wafers, smart card modules, RFID tags, and standard package options are listed. Ordering codes indicate specific options to be used with the device number (e.g., AT88SC6416CRF-MR1 denotes the 64K CryptoRF® in the standard RF smart card module).

- Ordering code options in **BOLD** are most commonly sold and may have reduced leadtimes.
- Those codes in regular type are also available.
- Blank areas indicate “not available”.

The following pages give details of the package options for the various ordering codes. Package options are Green compliant (exceeds RoHS).



---

## CryptoRF® and Secure RF

---

## Standard Product Offerings





## 1. CryptoRF

Table 1. CryptoRF

CryptoRF Devices	Tuning Capacitor	6 mil Wafer 150 mm, No Saw	6 mil Wafer 150 mm, 18 um Ni-Au Bumped, No Saw	RF Smart Card Module	Square RFID Tag	Round RFID Tag
		(Industrial Temp)	(Industrial Temp)	(Commercial Temp)	(Commercial Temp)	(Commercial Temp)
AT88RF04C	82 pF	-WA1	-WA1B	-MR1G	-MX1G	-MY1G
AT88SC0808CRF	82 pF	-WA1	-WA1B	-MR1	-MX1	-MY1
AT88SC1616CRF	82 pF	-WA1	-WA1B	-MR1	-MX1	-MY1
AT88SC3216CRF	82 pF	-WA1	-WA1B	-MR1	-MX1	-MY1
AT88SC6416CRF	82 pF	-WA1	-WA1B	-MR1	-MX1	-MY1

## 2. CryptoRF Reader

Table 2. ISO/IEC 14443 Type B RF Reader

RF Reader Devices	36 pin QFN 6x6 mm, Bulk	36 pin QFN 6x6 mm, T&R
	(Industrial Temp)	(Industrial Temp)
AT88RF1354	-ZU	-ZU-T

3. CryptoRF : MR1 Module

Ordering Code: AT88RF04C-MR1G and AT88SCxxxxCRF-MR1

Figure 1. AT88RF04C-MR1G and AT88SCxxxxCRF-MR1

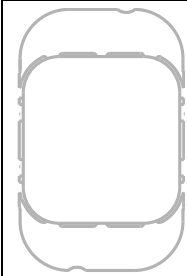
	<p><b>Module Size: M5</b> <b>Dimension*: 5.06 x 8.00 [mm]</b> <b>Glob Top: Square - 4.8 x 5.1 [mm]</b> <b>Thickness: 0.38 [mm]</b> <b>Pitch: 9.5 mm</b></p>
<p><b>Products:</b></p> <ul style="list-style-type: none"><li>• AT88RF04C</li><li>• AT88SC0808CRF</li><li>• AT88SC1616CRF</li><li>• AT88SC3216CRF</li><li>• AT88SC6416CRF</li></ul>	



5. CryptoRF: MY1 Epoxy Glass RFID Tag

Ordering Code: AT88RF04C-MY1G AT88SCxxxxCRF-MY1

Figure 3. AT88RF04C-MY1G and AT88SCxxxxCRF-MY1

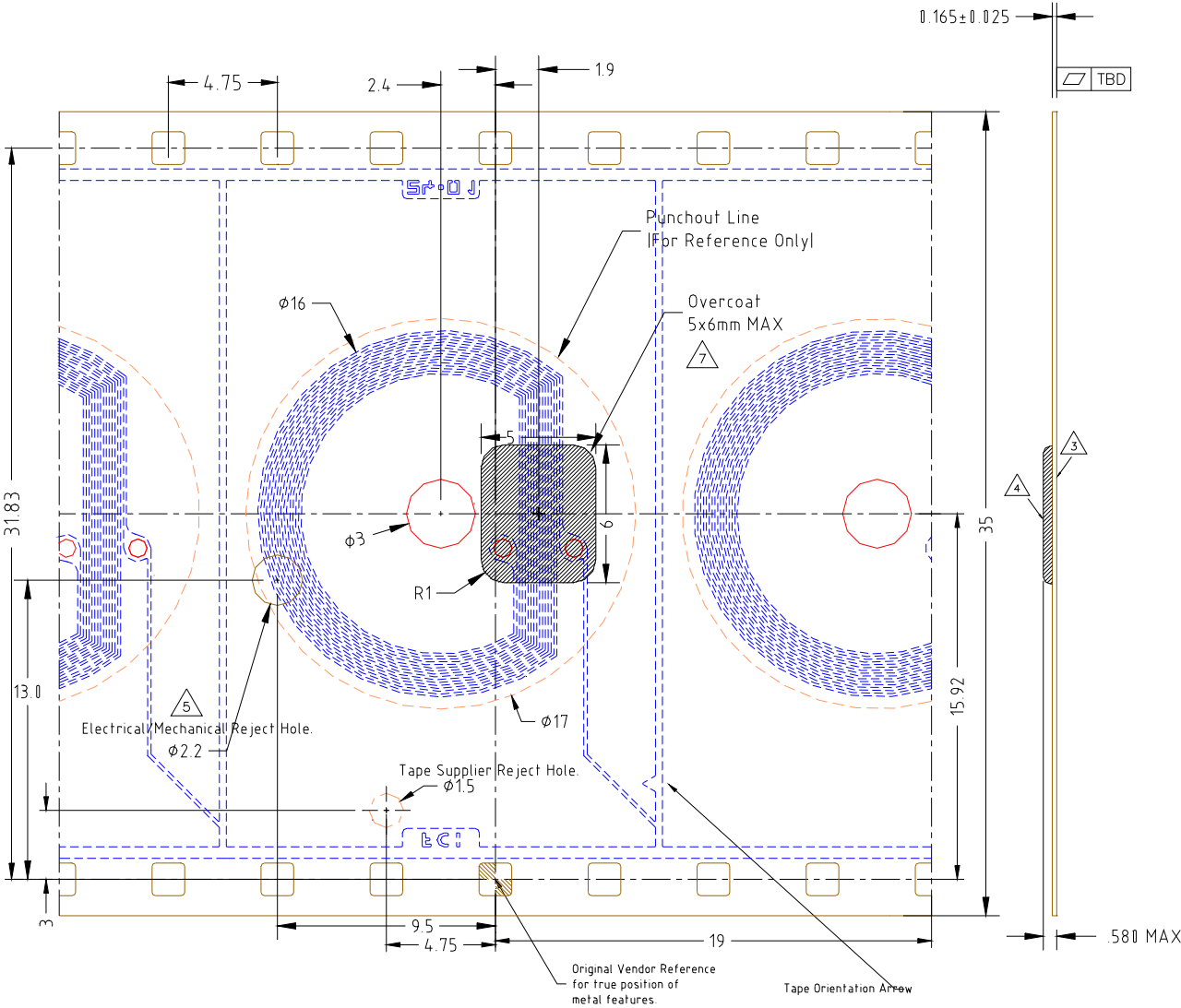

## 6. CryptoRF Reader Ordering Codes

Ordering Code: **AT88RF1354-ZU Bulk (Trays)**  
**AT88RF1354-ZU-T Tape and Reel**

Figure 4. AT88RF1354-ZU Bulk (Trays); AT88RF1354-ZU-T Tape and Reel

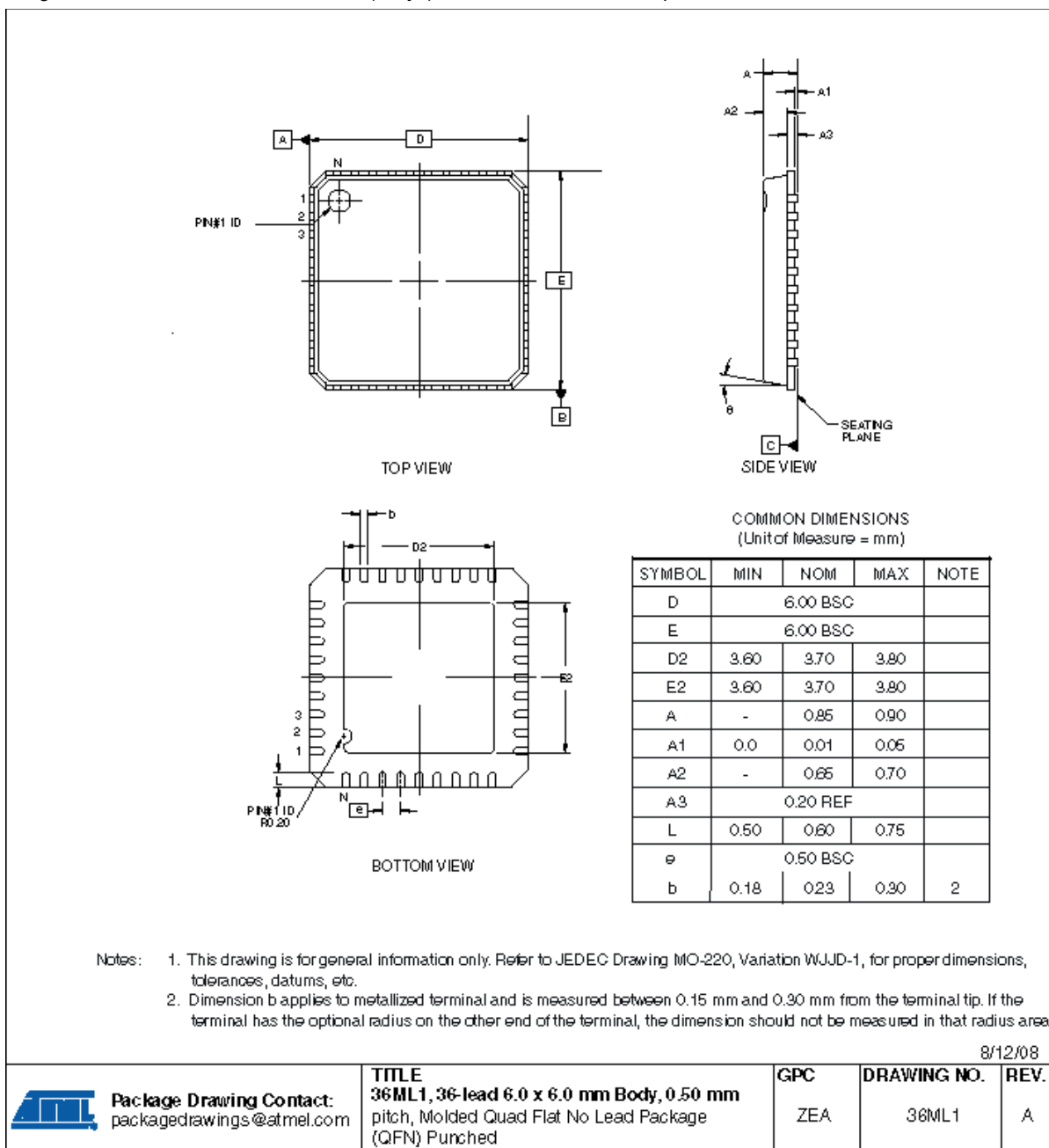

7. Index

7.1. Figures Index

Figure 1. AT88RF04C-MR1G and AT88SCxxxxCRF-MR1 ..... 3

Figure 2. AT88RF04C-MX1G and AT88SCxxxxCRF-MX1 ..... 4

Figure 3. AT88RF04C-MY1G and AT88SCxxxxCRF-MY1 ..... 5

Figure 4. AT88RF1354-ZU Bulk (Trays); AT88RF1354-ZU-T Tape and Reel ..... 6

7.2. Tables Index

Table 1. CryptoRF ..... 2

Table 2. ISO/IEC 14443 Type B RF Reader ..... 2

Table 3. Revision History ..... 8





## Revision History

Table 3. Revision History

Doc. Rev.	Date	Comments
5047C	03/2009	Document updated.
5047B	03/2006	Document updated.
5047A	05/2003	Initial document release.





---

## Headquarters

### **Atmel Corporation**

2325 Orchard Parkway  
San Jose, CA 95131  
USA  
Tel: 1(408) 441-0311  
Fax: 1(408) 487-2600

---

## International

### **Atmel Asia**

Room 1219  
Chinachem Golden Plaza  
77 Mody Road Tsimshatsui  
East Kowloon  
Hong Kong  
Tel: (852) 2721-9778  
Fax: (852) 2722-1369

### **Atmel Europe**

Le Krebs  
8, Rue Jean-Pierre Timbaud  
BP 309  
78054 Saint-Quentin-en-  
Yvelines Cedex  
France  
Tel: (33) 1-30-60-70-00  
Fax: (33) 1-30-60-71-11

### **Atmel Japan**

9F, Tonetsu Shinkawa Bldg.  
1-24-8 Shinkawa  
Chuo-ku, Tokyo 104-0033  
Japan  
Tel: (81) 3-3523-3551  
Fax: (81) 3-3523-7581

---

## Product Contact

### **Web Site**

[www.atmel.com](http://www.atmel.com)

### **Technical Support**

[cryptorf@atmel.com](mailto:cryptorf@atmel.com)

### **Sales Contact**

[www.atmel.com/contacts](http://www.atmel.com/contacts)

### **Literature Requests**

[www.atmel.com/literature](http://www.atmel.com/literature)

---

**Disclaimer:** The information in this document is provided in connection with Atmel products. No license, express or implied, by estoppel or otherwise, to any intellectual property right is granted by this document or in connection with the sale of Atmel products. **EXCEPT AS SET FORTH IN ATMEL'S TERMS AND CONDITIONS OF SALE LOCATED ON ATMEL'S WEB SITE, ATMEL ASSUMES NO LIABILITY WHATSOEVER AND DISCLAIMS ANY EXPRESS, IMPLIED OR STATUTORY WARRANTY RELATING TO ITS PRODUCTS INCLUDING, BUT NOT LIMITED TO, THE IMPLIED WARRANTY OF MERCHANTABILITY, FITNESS FOR A PARTICULAR PURPOSE, OR NON-INFRINGEMENT. IN NO EVENT SHALL ATMEL BE LIABLE FOR ANY DIRECT, INDIRECT, CONSEQUENTIAL, PUNITIVE, SPECIAL OR INCIDENTAL DAMAGES (INCLUDING, WITHOUT LIMITATION, DAMAGES FOR LOSS OF PROFITS, BUSINESS INTERRUPTION, OR LOSS OF INFORMATION) ARISING OUT OF THE USE OR INABILITY TO USE THIS DOCUMENT, EVEN IF ATMEL HAS BEEN ADVISED OF THE POSSIBILITY OF SUCH DAMAGES.** Atmel makes no representations or warranties with respect to the accuracy or completeness of the contents of this document and reserves the right to make changes to specifications and product descriptions at any time without notice. Atmel does not make any commitment to update the information contained herein. Unless specifically provided otherwise, Atmel products are not suitable for, and shall not be used in, automotive applications. Atmel's products are not intended, authorized, or warranted for use as components in applications intended to support or sustain life.

© 2009 Atmel Corporation. All rights reserved. Atmel®, Atmel logo and combinations thereof, CryptoRF® and others, are registered trademarks or trademarks of Atmel Corporation or its subsidiaries. Other terms and product names may be trademarks of others.



Компания «ЭлектроПласт» предлагает заключение долгосрочных отношений при поставках импортных электронных компонентов на взаимовыгодных условиях!

Наши преимущества:

- Оперативные поставки широкого спектра электронных компонентов отечественного и импортного производства напрямую от производителей и с крупнейших мировых складов;
- Поставка более 17-ти миллионов наименований электронных компонентов;
- Поставка сложных, дефицитных, либо снятых с производства позиций;
- Оперативные сроки поставки под заказ (от 5 рабочих дней);
- Экспресс доставка в любую точку России;
- Техническая поддержка проекта, помощь в подборе аналогов, поставка прототипов;
- Система менеджмента качества сертифицирована по Международному стандарту ISO 9001;
- Лицензия ФСБ на осуществление работ с использованием сведений, составляющих государственную тайну;
- Поставка специализированных компонентов (Xilinx, Altera, Analog Devices, Intersil, Interpoint, Microsemi, Aeroflex, Peregrine, Syfer, Eurofarad, Texas Instrument, Miteq, Cobham, E2V, MA-COM, Hittite, Mini-Circuits, General Dynamics и др.);

Помимо этого, одним из направлений компании «ЭлектроПласт» является направление «Источники питания». Мы предлагаем Вам помощь Конструкторского отдела:

- Подбор оптимального решения, техническое обоснование при выборе компонента;
- Подбор аналогов;
- Консультации по применению компонента;
- Поставка образцов и прототипов;
- Техническая поддержка проекта;
- Защита от снятия компонента с производства.



#### Как с нами связаться

**Телефон:** 8 (812) 309 58 32 (многоканальный)

**Факс:** 8 (812) 320-02-42

**Электронная почта:** [org@eplast1.ru](mailto:org@eplast1.ru)

**Адрес:** 198099, г. Санкт-Петербург, ул. Калинина, дом 2, корпус 4, литера А.