

Figure 1

## 1. INTRODUCTION

AMP\* Crimping Die Assemblies 90347-2 (shown in Figure 1), 90348-2, and 90349-2 are designed to be used in AMPORAPOWER\* Pneumatic Tool 69365 or Hand Crimping Tool 69710 or 69710-1 to crimp High Current contacts listed in Figure 2.

For specific information on operating the pneumatic tool, refer to customer manual 409-1983, and for the hand crimping tools, refer to 408-2095. Read these instructions and referenced instructions before crimping any contacts.

**NOTE**

*Dimensions in this instruction sheet are in millimeters [with inches in brackets]. Figures are not drawn to scale.*

Reasons for reissue of this instruction sheet are provided in Section 6, REVISION SUMMARY.

## 2. DESCRIPTION

The die assemblies feature two stationary dies (crimpers), two movable dies (anvils), and a contact support.

The stationary dies have chamfered corners. The applicable wire size range is marked on the FRONT of the die. The moving dies have square corners. When mated, the dies form one crimping chamber. The contact support prevents the contact from bending during the crimping procedure.

## 3. CRIMPING PROCEDURE

Install the dies according to the instructions packaged with the tooling. Then proceed as follows:

1. Refer to Figure 2, and select stranded wire of specified size and insulation diameter. Strip the wire to the length indicated—do NOT cut or nick the wire strands.

### Typical High Current Contact

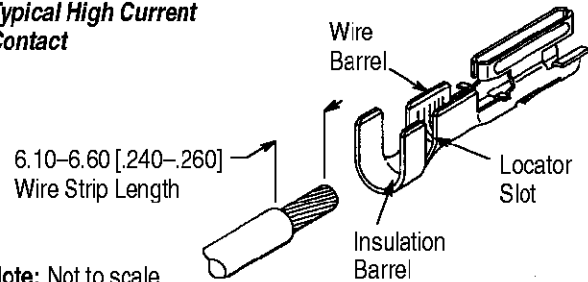

Note: Not to scale

STRANDED WIRE		CONTACT		CRIMPING DIE
SIZE (AWG)	INSUL DIA	STRIP	LOOSE PIECE	
16-14	6.86 [.270] Max	350651-1	350822-1	90347-2
12-10	6.35-9.14 [.250-.360]	350650-1	350821-1	90349-2
8				90348-2

Figure 2

2. Insert the contact, insulation barrel first, into the crimping chamber from the BACK of the die assembly.
3. Position the contact in the dies so that the open end of the insulation barrel faces the die retaining screw of the crimpers. Make sure that the locator slot is against the crimper. See Figure 3.
4. Hold contact in position, and close the dies just enough to hold the contact in place—do NOT deform the insulation barrel or wire barrel.
5. Insert a properly stripped wire into the contact insulation barrel.
6. Holding wire in place, actuate the tool through a complete cycle. Then allow the dies to open FULLY.
7. Remove the crimped contact from the dies, and inspect the crimp according to the following:
  - Wire barrel seam must be completely closed with no evidence of loose wire strands

**Crimping Contact**

Figure 3

- End of wire must be flush with or extend slightly beyond front of contact wire barrel
- Wire insulation must not be inside contact wire barrel
- Wire conductors and insulation must be visible between the contact wire barrel and insulation barrel

**NOTE**

For specific crimp inspection requirements, refer to Application Specification 114-1004.

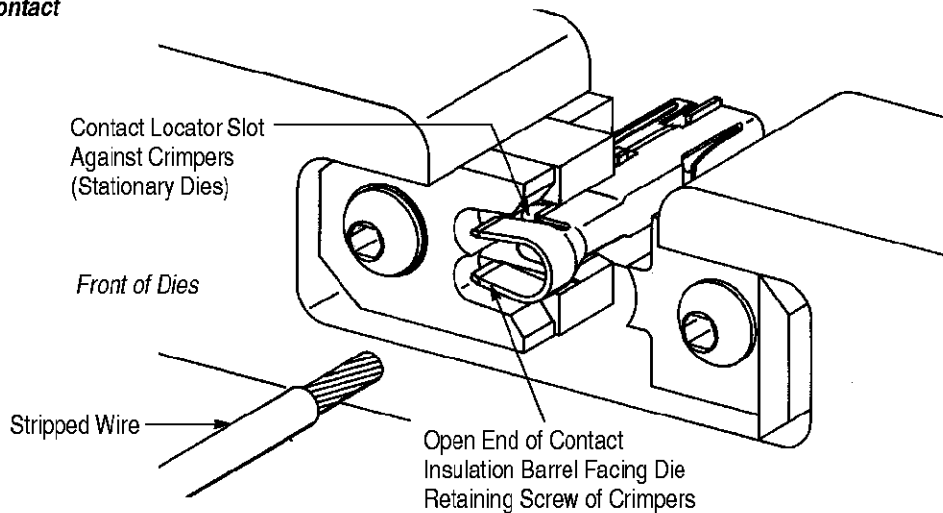
**4. MAINTENANCE AND INSPECTION**

The die assembly is inspected before shipment. It is recommended that the dies be inspected immediately upon arrival at your facility to ensure that the dies were not damaged during shipment.

**4.1. Daily Maintenance**

Remove all foreign particles with a clean, soft brush, or a clean, soft, lint-free cloth. Make sure the proper die retaining screws are in place, and secured with the proper retaining rings. If foreign matter cannot be removed easily, or if the proper replacement parts are not available, refer to Section 5, REPLACEMENT AND REPAIR.

Make certain all bearing surfaces are protected with a THIN coat of any good SAE 20 motor oil. Do NOT oil excessively. When dies are not in use, store them in a clean, dry area.

**4.2. Periodic Inspection**

Regular inspections should be performed by quality control personnel. A record of scheduled inspections should remain with the die assembly and/or be supplied to personnel responsible for the dies.

Though recommendations call for at least one inspection a month, the inspection frequency should be based on the amount of use, ambient working conditions, operator training and skill, and established company standards. These inspections should be performed in the following sequence:

**A. Visual Inspection**

1. Remove all lubrication and accumulated film by immersing the dies in a suitable commercial degreaser that will not affect paint or plastic material.
2. Make certain all die retaining screws, retaining rings, and die components are in place. If replacements are necessary, refer to parts listed in Section 5, REPLACEMENT AND REPAIR.
3. Check all bearing surfaces for wear. Remove and replace worn components. Refer to Section 5 for list of replacement parts.
4. Inspect the crimp area for flattened, chipped, worn, cracked, or broken areas. If damage to any part is evident, refer to Section 6 for information on obtaining customer repair service.

**B. Crimp Height Inspection**

This inspection requires the use of a micrometer with a modified anvil as shown in Figure 4. It is recommended using the modified micrometer (Crimp Height Comparator RS-1019-5LP) which can be purchased from:

Shearer Industrial Supply Co.                      VALCO  
20 North Penn Street                      or                      1410 Stonewood Drive  
York, PA 17401-1014                      Bethlehem, PA 18017-3527

Proceed as follows:

1. Select a contact and *maximum* size wire for the crimping chamber.

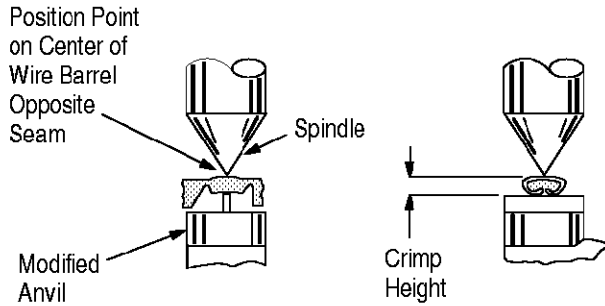

DIE ASSEMBLY	WIRE SIZE (AWG) (Max)	CRIMP HEIGHT DIMENSION ( $\pm 0.10$ [ $\pm .004$ ])
90347-2	14	2.31 [.091]
90348-2	8	3.78 [.149]
90349-2	10	3.28 [.129]

Figure 4

2. Refer to Section 3, CRIMPING PROCEDURE, and crimp the contact accordingly.

3. Using a crimp height comparator, measure wire barrel crimp height as shown in Figure 4. If the crimp height conforms to that shown, the die assembly is considered dimensionally correct. If not, refer to Section 5 for information on obtaining evaluation and repair.

For additional information concerning the use of the crimp height comparator, refer to 408-7424.

**5. REPLACEMENT AND REPAIR**

Customer-replaceable parts are listed in Figure 5. A complete inventory should be stocked and controlled to prevent lost time when replacement of parts is necessary. Parts other than those listed should be replaced by Tyco to ensure quality and reliability. Order replacement parts through your representative, or call 1-800-526-5142, or send a facsimile of your purchase order to 717-986-7605, or write to:

CUSTOMER SERVICE (038-035)  
 TYCO ELECTRONICS CORPORATION  
 PO BOX 3608  
 HARRISBURG PA 17105-3608

For customer repair service, please contact a representative at 1-800-526-5136.

**6. REVISION SUMMARY**

Revisions to this instruction sheet per EC 0990-0734-99 include:

- Updated document to corporate requirements
- Changed title of document
- Added Step 7 to Section 3
- Changed York Machinery to Shearer Industrial in Paragraph 4.2, B
- Replaced customer repair address with phone number

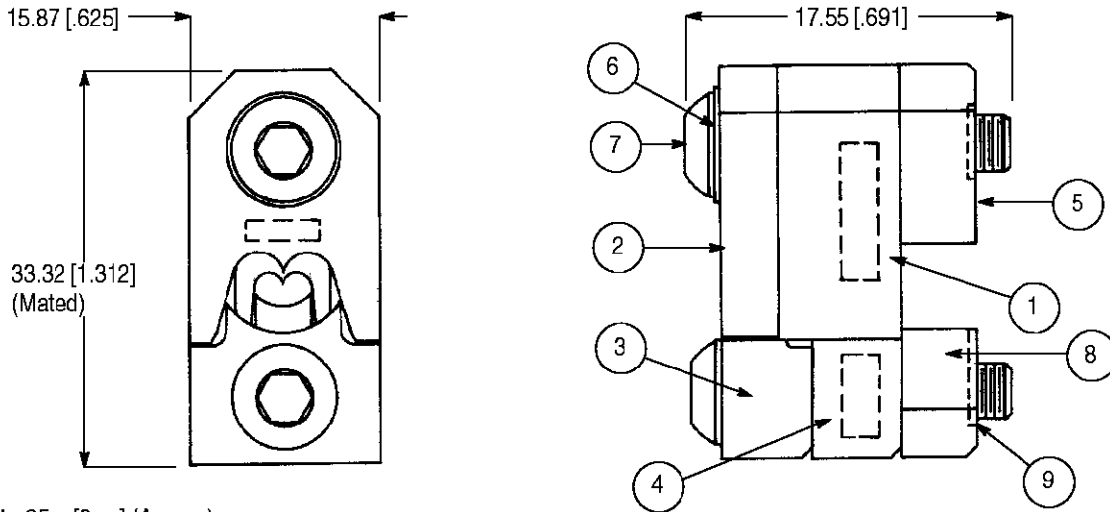

Weight: 85 g [3 oz] (Approx)

**REPLACEMENT PARTS**

ITEM	PART NUMBER FOR DIE ASSEMBLY			DESCRIPTION	QTY PER ASSEMBLY
	90347-2	90348-2	90349-2		
1	127085-1	127085-2	127085-3	CRIMPER, Wire	1
2	127069-1	127069-2	127069-2	CRIMPER, Insulation	1
3	127133-1	127133-2	127133-2	ANVIL, Insulation	1
4	125466-9	1-125466-0	1-125466-1	ANVIL, Wire	1
5	125470-4			SUPPORT	1
6	24088-7			WASHER, Curved	1
7	1-306131-3			SCREW, Retaining	2
8	1-125181-5			SPACER	1
9	1-21046-3			RING, Retaining	2

Figure 5



Компания «ЭлектроПласт» предлагает заключение долгосрочных отношений при поставках импортных электронных компонентов на взаимовыгодных условиях!

Наши преимущества:

- Оперативные поставки широкого спектра электронных компонентов отечественного и импортного производства напрямую от производителей и с крупнейших мировых складов;
- Поставка более 17-ти миллионов наименований электронных компонентов;
- Поставка сложных, дефицитных, либо снятых с производства позиций;
- Оперативные сроки поставки под заказ (от 5 рабочих дней);
- Экспресс доставка в любую точку России;
- Техническая поддержка проекта, помощь в подборе аналогов, поставка прототипов;
- Система менеджмента качества сертифицирована по Международному стандарту ISO 9001;
- Лицензия ФСБ на осуществление работ с использованием сведений, составляющих государственную тайну;
- Поставка специализированных компонентов (Xilinx, Altera, Analog Devices, Intersil, Interpoint, Microsemi, Aeroflex, Peregrine, Syfer, Eurofarad, Texas Instrument, Miteq, Cobham, E2V, MA-COM, Hittite, Mini-Circuits, General Dynamics и др.);

Помимо этого, одним из направлений компании «ЭлектроПласт» является направление «Источники питания». Мы предлагаем Вам помощь Конструкторского отдела:

- Подбор оптимального решения, техническое обоснование при выборе компонента;
- Подбор аналогов;
- Консультации по применению компонента;
- Поставка образцов и прототипов;
- Техническая поддержка проекта;
- Защита от снятия компонента с производства.



#### Как с нами связаться

**Телефон:** 8 (812) 309 58 32 (многоканальный)

**Факс:** 8 (812) 320-02-42

**Электронная почта:** [org@eplast1.ru](mailto:org@eplast1.ru)

**Адрес:** 198099, г. Санкт-Петербург, ул. Калинина, дом 2, корпус 4, литера А.