

21-Watt, Universal, AC LED Driver Demoboard with Accurate Average-Mode, Constant Current Control

General Description

The HV9861ADB1 demoboard is a high-brightness LED driver employing the patented average-mode, constant current control scheme by Supertex Inc. The power conversion stage of the HV9861ADB1 consists of a diode bridge rectifier followed by a buck converter operating with fixed off-time of 20µs.

The HV9861ADB1 LED driver features tight regulation of the LED current within a few milliamps over the entire range of the input AC line and the output LED string voltage. The LED current accuracy is almost insensitive to the passive component tolerances, such as the output filter inductance or the timing resistor. The accuracy of the LED current is mainly determined by the internal 270mV \pm 3% reference voltage of the HV9861A control IC and by the external current sense resistor tolerance.

(Note, that the linear dimming input of the HV9861A disables switching, when its voltage falls below a 200mV threshold. Expect the LED driver to shut off when the LED current falls below 50 ~ 55mA.)

Connection Diagram

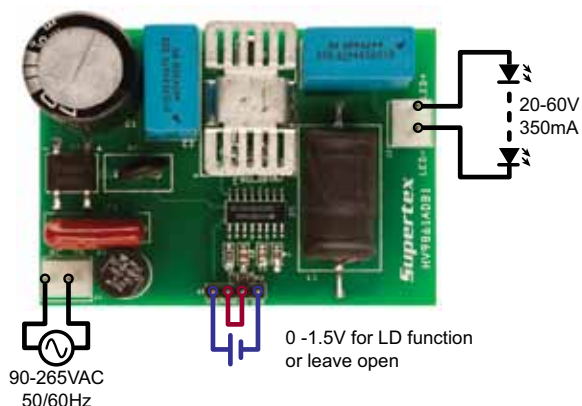

WARNING!!!

Do not connect earth-grounded test instruments. Doing so will short the AC line, resulting in damage to the instrument and/or the HV9861ADB1. Use floating high voltage differential probes or isolate the demoboard by using an isolating transformer.

Connections

1. Connect the input AC voltage between the AC IN terminals as shown in the connection diagram.
2. Connect the LED string between LED+ (anode of LED string) and LED- (cathode of LED string).
3. Connect the PWMD terminal to the VDD terminal using the jumper provided to enable the LED driver.
4. The current level can be adjusted by applying 0 - 1.5V between LD and GND. Leave LD floating to use the internal current setting.

PWM dimming can be achieved by applying a pulse-width-modulated square wave signal between the PWMD and GND pins.

The HV9861ADB1 features protection from an output short circuit condition. Open LED protection is inherent, since the output filter capacitor can accept the full rated rectified AC line voltage.

Please, note that the demoboard is not CISPR15 compliant. An additional input EMI filter circuit is required to make the board meet conducted electro-magnetic emission limits. Also, note that:

NO SAFETY ISOLATION OF THE LED LOAD FROM THE AC MAINS VOLTAGE IS PROVIDED!

Silk Screen

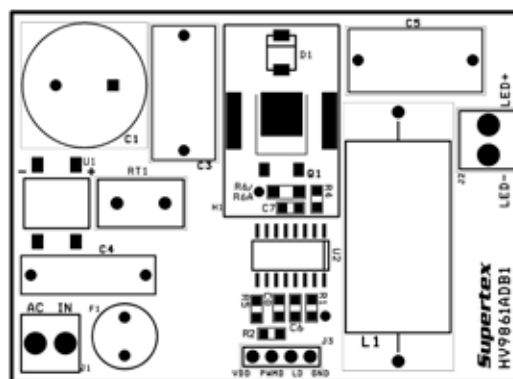

No galvanic isolation. Dangerous voltages are present when connected to the AC line.

PWM Dimming

The HV9861ADB1 is capable of being PWM dimmed by applying a square wave TTL compatible signal between PWMD and GND terminals. However, since there is no galvanic isolation on the board, care must be taken to prevent damage to the PWM dimming source and/or the HV9861ADB1. One simple way is to isolate the LED driver from the AC line using an isolation transformer. Another approach is to use an opto-isolator to drive the PWMD pin as shown in the following figure.

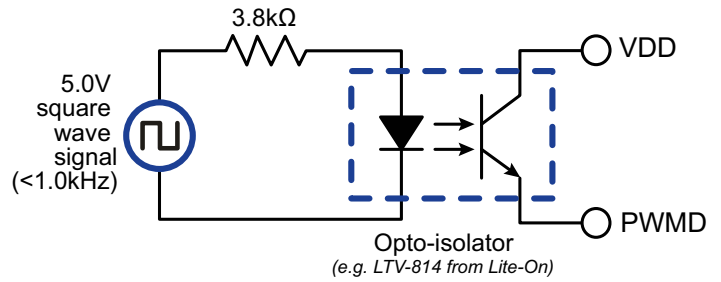

Specifications

Parameter	Value	Condition
Input voltage	90~265VAC, 50/60Hz	---
Output voltage	20~60V	---
Nominal output current	350mA±4%	---
Output current ripple	±15% (typical, depending on the type of LED)	120VAC, 60V/350mA
Full load efficiency	92%	120VAC, 60V/350mA
	91%	240VAC, 60V/350mA
Power factor	0.56	120VAC, 60V/350mA
	0.50	240VAC, 60V/350mA
Maximum input current	0.27A (RMS)	90VAC, 60V/350mA
Switching frequency (variable, T _{OFF} = 20μs)	29kHz	120VAC, 60V/350mA
	38kHz	240VAC, 60V/350mA
	40kHz	120VAC, 20V/350mA
	43kHz	240VAC, 20V/350mA
Open LED protection	YES	---
Output short circuit protection	YES	---
Dimensions	68.6mm X 49.6mm	---

Schematic

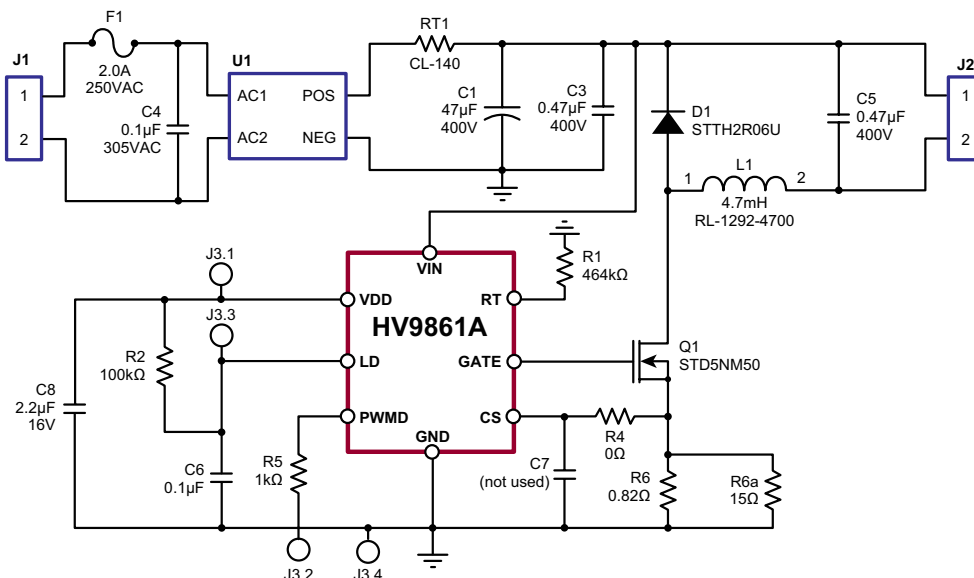

Typical Characteristics

Current Regulation vs. LED String Voltage

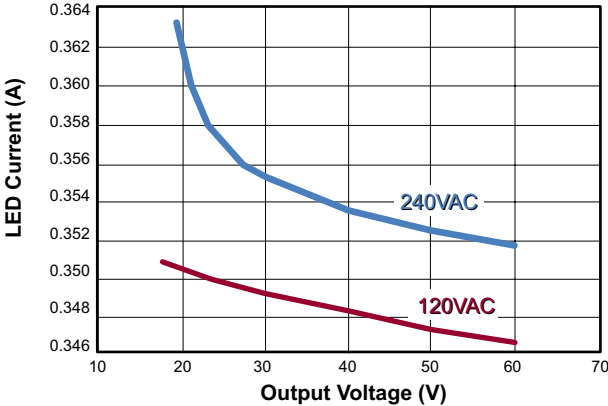

Output Short Circuit Response

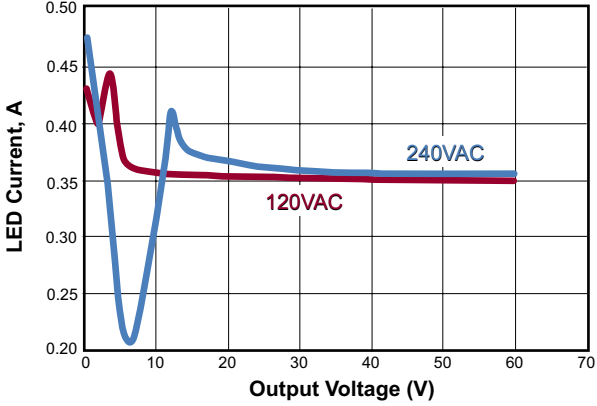

Current Regulation vs. AC Line Voltage

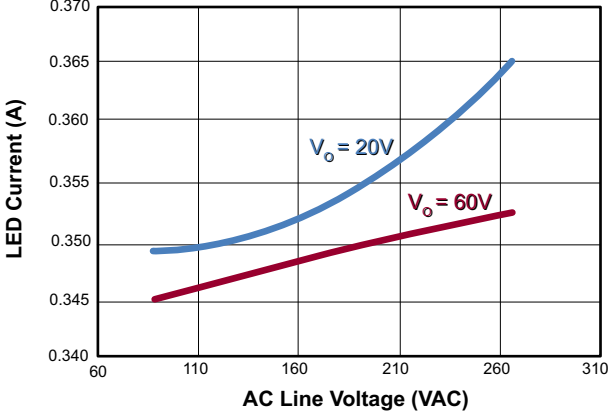

Efficiency

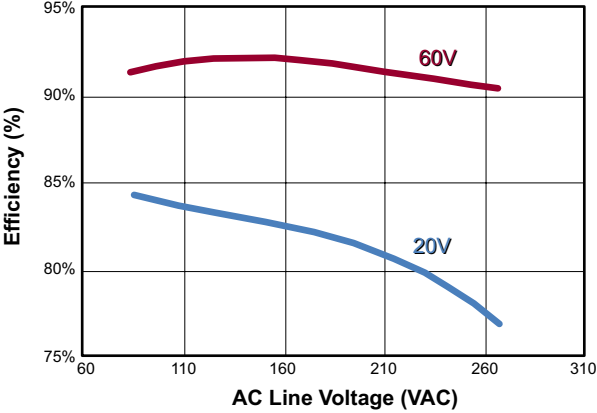

PWM Dimming Response

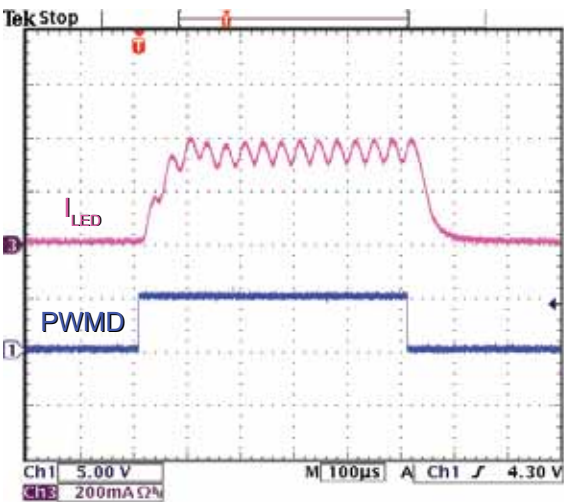

Short Circuit Current

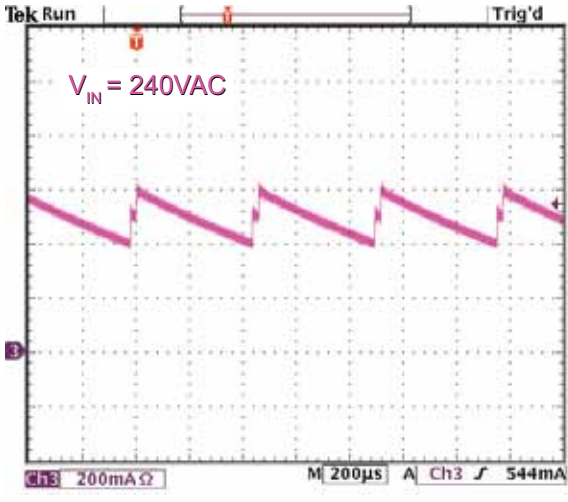

Bill of Materials

Item #	Quan	RefDes	Description	Package	Manufacturer	Manufacturer's Part Number
1	1	C1	47 μ F, 400V electrolytic capacitor	Radial	Panasonic	EEU-ED2G470
2	2	C3, C5	0.47 μ F, 400V metal film capacitor	Radial	EPCOS Inc	B32522C6474K
3	1	C4	0.1 μ F, 305VAC EMI suppression capacitor	Radial	EPCOS Inc	B32922C3104M
4	1	C6	0.1 μ F, 16V X7R ceramic chip capacitor	SMD0805	Panasonic	ECJ-2VB1C104K
5	1	C8	2.2 μ F, 16V X7R ceramic chip capacitor	SMD0805	TDK Corp	C2012X7R1C225K
6	1	D1	600V, 2A ultrafast diode	SMB	ST Micro	STTH2R06U
7	1	F1	2.0A, 250VAC time lag fuse	Radial	Cooper Bussman	SR-5-2A-BK
8	1	H1	15C/W DPAK heat sink	SMT	Aavid	7106PD
9	2	J1, J2	2 position, 0.156" pitch, vertical header	Thru-Hole	Molex	26-48-1021
10	1	J3	4 position, 0.100" pitch, vertical header	Thru-Hole	Molex	22-03-2041
11	1	L1	4.7mH, 400mA rms, 470mA SAT inductor	Axial	Renco USA	RL-1252-4700
12	1	Q1	550V, 0.7 Ω N-channel FET	DPAK	ST Micro	STD5NM50
13	1	RT1	50 Ω NTC inrush limiter	Thru-Hole	GE Sensing	CL-140
14	1	R1	464k Ω , 1/8W, 1% chip resistor	SMD0805	---	---
15	1	R2	100k Ω , 1/8W, 1% chip resistor	SMD0805	---	---
16	1	R5	1k Ω , 1/8W, 1% chip resistor	SMD0805	---	---
17	1	R6	0.82 Ω , 1/4W, 1% chip resistor	SMD1206	---	---
18	1	R6a	15 Ω , 1/4W, 1% chip resistor	SMD1206	---	---
19	1	U1	400V, 1A single phase diode bridge	DF-S	Diodes Inc	DF04S
20	1	U2	Universal LED Driver	SO-16	Supertex	HV9861ANG-G

Supertex inc. does not recommend the use of its products in life support applications, and will not knowingly sell them for use in such applications unless it receives an adequate "product liability indemnification insurance agreement." **Supertex inc.** does not assume responsibility for use of devices described, and limits its liability to the replacement of the devices determined defective due to workmanship. No responsibility is assumed for possible omissions and inaccuracies. Circuitry and specifications are subject to change without notice. For the latest product specifications refer to the **Supertex inc.** (website: <http://www.supertex.com>)



Компания «ЭлектроПласт» предлагает заключение долгосрочных отношений при поставках импортных электронных компонентов на взаимовыгодных условиях!

Наши преимущества:

- Оперативные поставки широкого спектра электронных компонентов отечественного и импортного производства напрямую от производителей и с крупнейших мировых складов;
- Поставка более 17-ти миллионов наименований электронных компонентов;
- Поставка сложных, дефицитных, либо снятых с производства позиций;
- Оперативные сроки поставки под заказ (от 5 рабочих дней);
- Экспресс доставка в любую точку России;
- Техническая поддержка проекта, помощь в подборе аналогов, поставка прототипов;
- Система менеджмента качества сертифицирована по Международному стандарту ISO 9001;
- Лицензия ФСБ на осуществление работ с использованием сведений, составляющих государственную тайну;
- Поставка специализированных компонентов (Xilinx, Altera, Analog Devices, Intersil, Interpoint, Microsemi, Aeroflex, Peregrine, Syfer, Eurofarad, Texas Instrument, Miteq, Cobham, E2V, MA-COM, Hittite, Mini-Circuits, General Dynamics и др.);

Помимо этого, одним из направлений компании «ЭлектроПласт» является направление «Источники питания». Мы предлагаем Вам помощь Конструкторского отдела:

- Подбор оптимального решения, техническое обоснование при выборе компонента;
- Подбор аналогов;
- Консультации по применению компонента;
- Поставка образцов и прототипов;
- Техническая поддержка проекта;
- Защита от снятия компонента с производства.



Как с нами связаться

Телефон: 8 (812) 309 58 32 (многоканальный)

Факс: 8 (812) 320-02-42

Электронная почта: org@eplast1.ru

Адрес: 198099, г. Санкт-Петербург, ул. Калинина, дом 2, корпус 4, литера А.