



<i>Product Specification</i>	<i>Model:</i>	AWY-480272T43PC05	<i>Rev. No.</i>	<i>Issued Date.</i>	<i>Page.</i>
			A	2015/01/22	1/26

Thin Film Transistor LCD MODULE
MODEL: AWY-480272T43PC05
Customer's No.:

Acceptance

3504 Lake Lynda Drive, Suite 110,
Orlando, FL., USA 32817

Approved and Checked by

Approved by	Checked by	Made by



Product Specification	Model:	AWY-480272T43PC05	Rev. No.	Issued Date.	Page.
			A	2015/01/22	2/26

CONTENTS

NO.	ITEM	PAGE
	COVER	1
1.	CONTENTS	2
2.	RECORD OF REVISION	3
	TFT LCD MODULE	
3.	General specification	4
4.	Mechanical data	4
5.	Absolute maximum ratings	5
6.	Electrical characteristics	6
7.	Optical characteristics	7~9
8.	Outline dimension	10
9.	Block diagram	11
10.	Input terminal pin assignment	12~13
11.	Timing characteristics	14~16
12.	Driver ic control algorithms	17
13.	Reliability test items	17
14.	Quality assurance	18~21
15.	General precautions	21~23
	TOUCH PANEL MODULE	
1.	Basic features	24
2.	Electrical characteristics	24
3.	Optical characteristics	25
4.	Interface diagram	25
5.	Cosmetic testing condition	25
6.	Environmental characteristic	26
7.	Pin assignments	26



<i>Product Specification</i>	<i>Model:</i>	AWY-480272T43PC05	<i>Rev. No.</i>	<i>Issued Date.</i>	<i>Page.</i>
			A	2015/01/22	3/26

RECORD OF REVISION

DATE	REV.	PAGE	SUMMARY
2015/01/22	A	All	New issue.



Product Specification	Model:	AWY-480272T43PC05	Rev. No.	Issued Date.	Page.
			A	2015/01/22	4/26

TFT LCD MODULE

3. General specifications

3.1 General specifications

It is a color active matrix TFT (Thin Film Transistor) liquid crystal display (LCD) that uses the amorphous silicon TFT as a switching devices. This model is composed of a Transmissive type TFT-LCD Panel, a driver circuit, a back-light unit and a capacitive touch panel.

3.2 Features

- High image quality a-Si TFT LCD module.
- 16.7M color number.
- Support 24-bit parallel (RGB) input mode
- High contrast, high brightness
- Low power consumption.

4. Mechanical data

No	Item	Specification	Remark
1	Type	Transmissive	--
2	Display Mode	Normally White	--
3	Pixel Element	a-Si TFT	--
4	Screen Size	4.3inch	--
5	Resolution	480(RGB) x 272	--
6	Active Area	95.04 (W) x 53.856(L) (mm)	--
7	Pixel Size	0.198 x 0.198 (mm)	--
8	Color Arrangement	RGB-stripe	--
9	Assembly Type	COG	--
10	Back Light	LED	--
11	Good Viewing Direction	12 o'clock	--
12	Gray Scale Inversion Direction	6 o'clock	--
13	Weight	TBD	g
14	Module Dimension	105.5(W) x 67.2(L) x 4.4(H) (mm)	--
15	Panel Maker	CMI	--



Product Specification	Model:	AWY-480272T43PC05	Rev. No.	Issued Date.	Page.
			A	2015/01/22	5/26

5. Absolute maximum ratings

5.1 Electrical absolute maximum ratings

(1) TFT-LCD panel absolute maximum ratings

Ta=25°C

Item	Symbol	Condition	Standard Value		Unit	Remark
			Min.	Max.		
Power supply voltage	VDD	GND=0V	-0.3	4.5	V	--
Logic Input Signal	Vin		-0.3	4.5	V	--

* If the LSI is used above these absolute maximum ratings, it may become permanently damaged. Using the LSI within the following electrical characteristics limit is strongly recommended for normal operation. If these electrical characteristic conditions are also exceeded, the LSI will malfunction and cause poor reliability.

(2) Back-light unit

Ta=25°C

Item	Symbol	Min.	Max.	Unit	Remark
Current	I _{LED}	--	25	mA	--

5.2 Environmental absolute maximum ratings

Item	Symbol	Min.	Max.	Unit	Remark
Operation temperature range	Top	-20	70	°C	Ambient
Storage temperature range	Tst	-30	80	°C	Ambient

- (1) Corrosive gas environment is not acceptable.
- (2) TFT-LCD color will change slightly depending on environment temperature.
This phenomenon is reversible.



Product Specification	Model:	AWY-480272T43PC05	Rev. No.	Issued Date.	Page.
			A	2015/01/22	6/26

6. Electrical characteristics

(1) TFT-LCD module

Ta=25°C

Item	Symbol	Min.	Typ.	Max.	Unit	Remark
Power Supply	VDD	3.1	3.3	3.5	V	--
Operating Current	IDD	--	--	25	mA	--
High level input voltage	VIH	0.8VDD	--	VDD	V	NOTE (1)
Low level input voltage	VIL	0	--	0.2VDD	V	

NOTE(1) : CLK , DE , R0~R7 , G0~G7 , B0~B7

(2) Back-light unit

Ta=25°C

Item	Symbol	Min.	Typ.	Max.	Unit	Remark
Forward Voltage	VLED	26.1	28.8	32.4	V	NOTE (1)
Forward current	ILED	--	20	--	mA	--
Life Time	Lf	25,000	(50,000)	--	Hrs	NOTE (2)

NOTE (1) : The LEDs is serial type.

NOTE (2) : The LED operating life means brightness goes down to maximum 30% of initial brightness, typical operating life time is estimated data.

The LED lifetime could be decreased if operating ILED is larger than 20mA.

NOTE (3) : Back-light circuit :

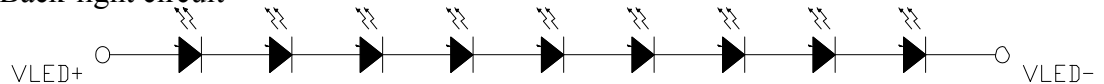

NOTE (4) : Current reduction rate of LED backlight is according to the graph indicated below :

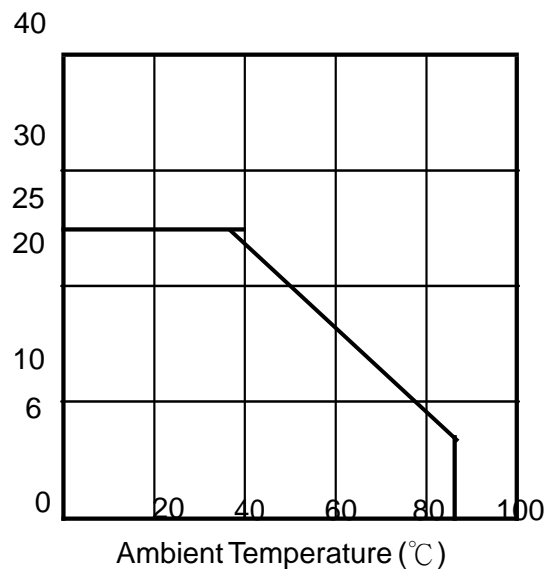



Product Specification	Model:	AWY-480272T43PC05	Rev. No.	Issued Date.	Page.
			A	2015/01/22	7/26

7. Optical characteristics

Ta=25°C , ILED=20mA

Item		Symbol	Condition	Min.	Typ.	Max.	Unit	Note
Brightness		B	θ=0° Normal viewing angle At the center of panel	400	500	--	cd/m ²	(1)
Contrast Ratio		C/R		--	500	--	--	(2)
Response Time		Tr		--	5	--	ms	(3)
		Tf		--	15	--		
Color chromatic ity	White	Wx		(0.230)	(0.280)	(0.330)	--	--
		Wy		(0.300)	(0.350)	(0.400)		
	Red	Rx		(0.552)	(0.602)	(0.652)	--	--
		Ry		(0.303)	(0.353)	(0.403)		
	Green	Gx		(0.292)	(0.342)	(0.392)	--	--
		Gy		(0.531)	(0.581)	(0.631)		
	Blue	Bx	(0.094)	(0.144)	(0.194)	--	--	
		By	(0.062)	(0.112)	(0.162)			
Viewing Angle	Top	θ _U	C/R ≥ 10 Backlight On	60	70	--	Deg.	(4)
	Bottom	θ _D		40	50	--		
	Left	θ _L		60	70	--		
	Right	θ _R		60	70	--		
Uniformity		Un	θ=0° Normal viewing angle	80	--	--	%	(5)



Product Specification	Model:	AWY-480272T43PC05	Rev. No.	Issued Date.	Page.
			A	2015/01/22	8/26

Note 1: The brightness test equipment setup

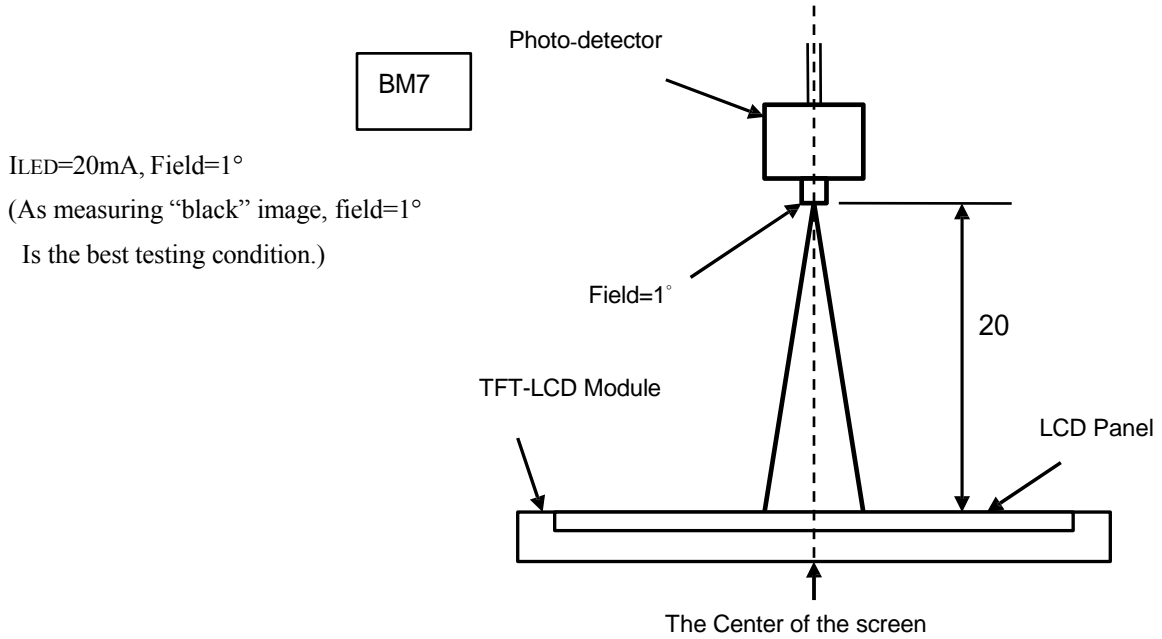

Note 2: Definition of contrast Ratio (C/R)

$$C/R = \frac{\text{Brightness When LCD is at "White" State}}{\text{Brightness When LCD is at "Black" State}}$$

Note 3: Definition of response time

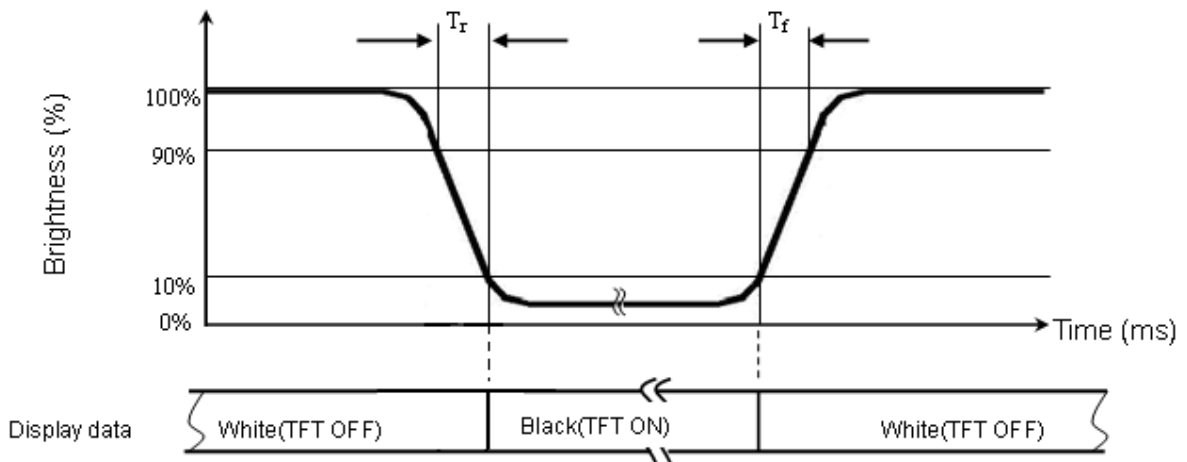



Product Specification	Model:	AWY-480272T43PC05	Rev. No.	Issued Date.	Page.
			A	2015/01/22	9/26

Note 4: Definition of viewing angle

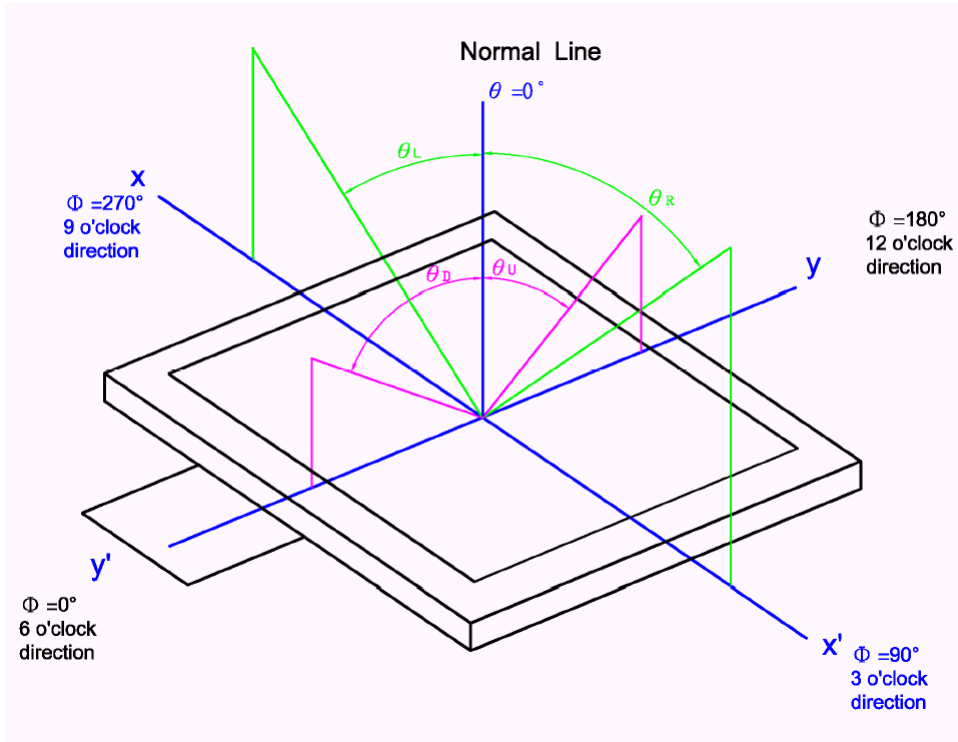

Note 5: Definition of uniformity (Un)

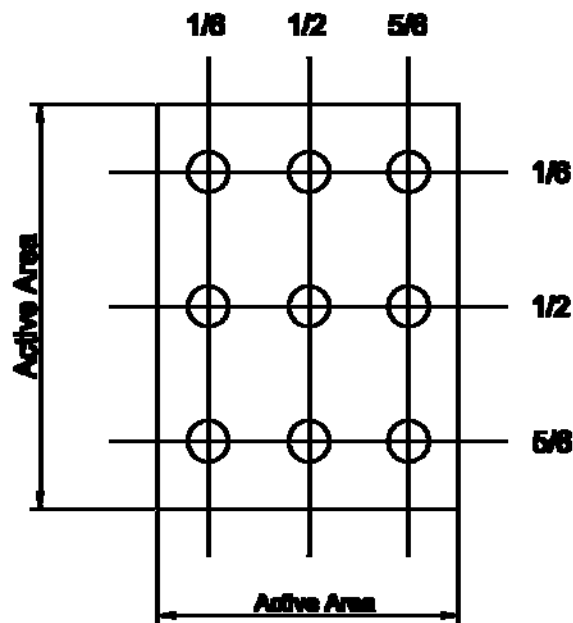

$$Un = \frac{Bmin}{Bmax}$$



Product Specification	Model:	AWY-480272T43PC05	Rev. No.	Issued Date.	Page.
			A	2015/01/22	11/26

9. Block diagram

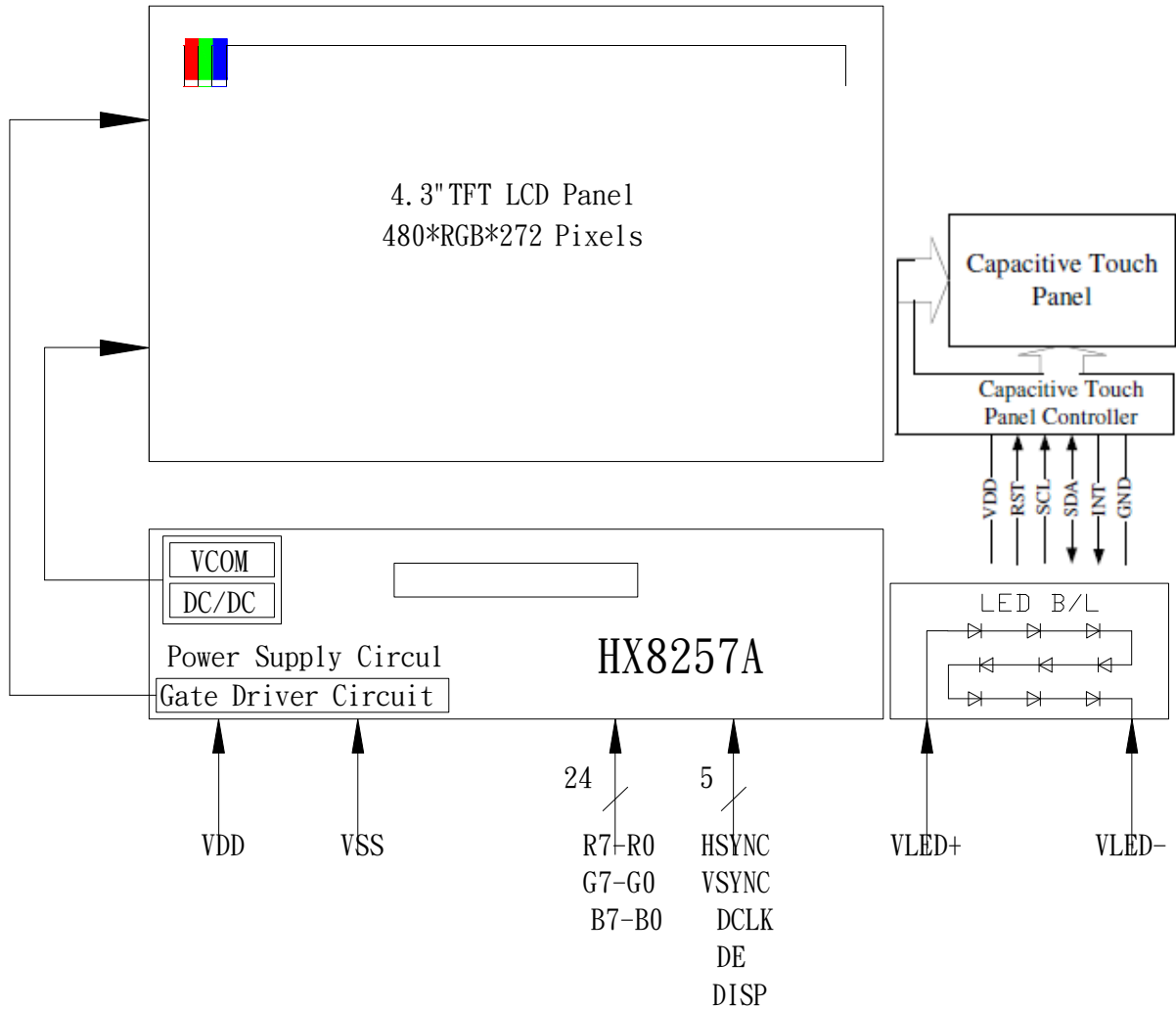



Product Specification	Model:	AWY-480272T43PC05	Rev. No.	Issued Date.	Page.
			A	2015/01/22	12/26

10. Input terminal pin assignment

10.1 Input signal & power

Pin no	Symbol	Description	Remark
1	VLED-	LED Ground	-
2	VLED+	LED Power	-
3	GND	Ground	-
4	VDD	Digital Power	-
5	R0	Red data bit 0	-
6	R1	Red data bit 1	-
7	R2	Red data bit 2	-
8	R3	Red data bit 3	-
9	R4	Red data bit 4	-
10	R5	Red data bit 5	-
11	R6	Red data bit 6	-
12	R7	Red data bit 7	-
13	G0	Green data bit 0	-
14	G1	Green data bit 1	-
15	G2	Green data bit 2	-
16	G3	Green data bit 3	-
17	G4	Green data bit 4	-
18	G5	Green data bit 5	-
19	G6	Green data bit 6	-
20	G7	Green data bit 7	-
21	B0	Blue data bit 0	-
22	B1	Blue data bit 1	-
23	B2	Blue data bit 2	-
24	B3	Blue data bit 3	-
25	B4	Blue data bit 4	-
26	B5	Blue data bit 5	-
27	B6	Blue data bit 6	-
28	B7	Blue data bit 7	-
29	GND	Ground	-
30	DCLK	Clock signal for data latching and internal counter of the timing controller	-

Microtips Technology USA

3504 Lake Lynda Drive, Suite 110, Orlando, FL. USA 32817



Product Specification	Model:	AWY-480272T43PC05	Rev. No.	Issued Date.	Page.
			A	2015/01/22	13/26

Pin no	Symbol	Description	Remark
31	DISP	Display on/off mode control	-
32	HSYNC	Horizontal sync input	-
33	VSYNC	Vertical sync input	-
34	DE	Data Enable Control	-
35	NC	NOCONNECT	-
36	GND	Ground	-
37	NC	NOCONNECT	-
38	NC	NOCONNECT	-
39	NC	NOCONNECT	-
40	NC	NOCONNECT	-



Product Specification	Model:	AWY-480272T43PC05	Rev. No.	Issued Date.	Page.
			A	2015/01/22	14/26

11. Timing characteristics

11.1 AC characteristics

The HX8257-A both supports DE mode and Sync mode timing. The mode was decided by DE signal internally. When DE is pulled low, the HX8257-A uses HS+VS for timing control and this timing mode is sync mode. When DE is pulled high for active data and pulled low for blanking data, the HX8257-A uses DE for timing control and this timing mode is DE mode. The detail timing chart showed below.

Clock and data input timing diagram

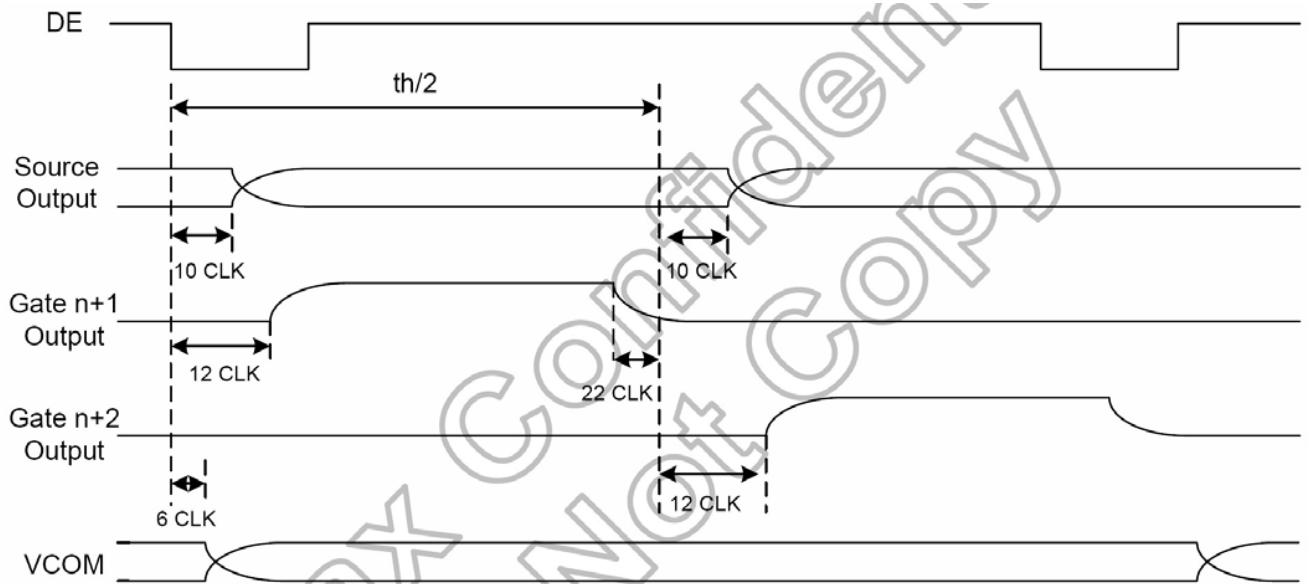



Product Specification	Model:	AWY-480272T43PC05	Rev. No.	Issued Date.	Page.
			A	2015/01/22	15/26

11.2 Timing conditions

Parallel RGB input timing table

Parameter	Symbol	Spec.			Unit
		Min.	Typ.	Max.	
Clock cycle	$f_{CLK}^{(1)}$	-	9	15	MHz
Hsync cycle	$1/th$	-	17.14	-	KHz
Vsync cycle	$1/tv$	-	59.94	-	Hz
Horizontal Signal					
Horizontal cycle	th	525	525	605	CLK
Horizontal display period	thd	480	480	480	CLK
Horizontal front porch	thf	2	2	82	CLK
Horizontal pulse width	thp ⁽²⁾	2	41	41	CLK
Horizontal back porch	thb ⁽²⁾	2	2	41	CLK
Vertical Signal					
Vertical cycle	tv	285	286	399	H ⁽¹⁾
Vertical display period	tvd	272	272	272	H ⁽¹⁾
Vertical front porch	tvf	1	2	227	H ⁽¹⁾
Vertical pulse width	tvp ⁽²⁾	1	10	11	H ⁽¹⁾
Vertical back porch	tvb ⁽²⁾	1	2	11	H ⁽¹⁾

Note: (1) Unit: CLK=1/ f_{CLK} , H= th,

(2) It is necessary to keep $tvp+tvb=12$ and $thp+thb=43$ in sync mode. DE mode is unnecessary to keep it.

RGB input timing diagram

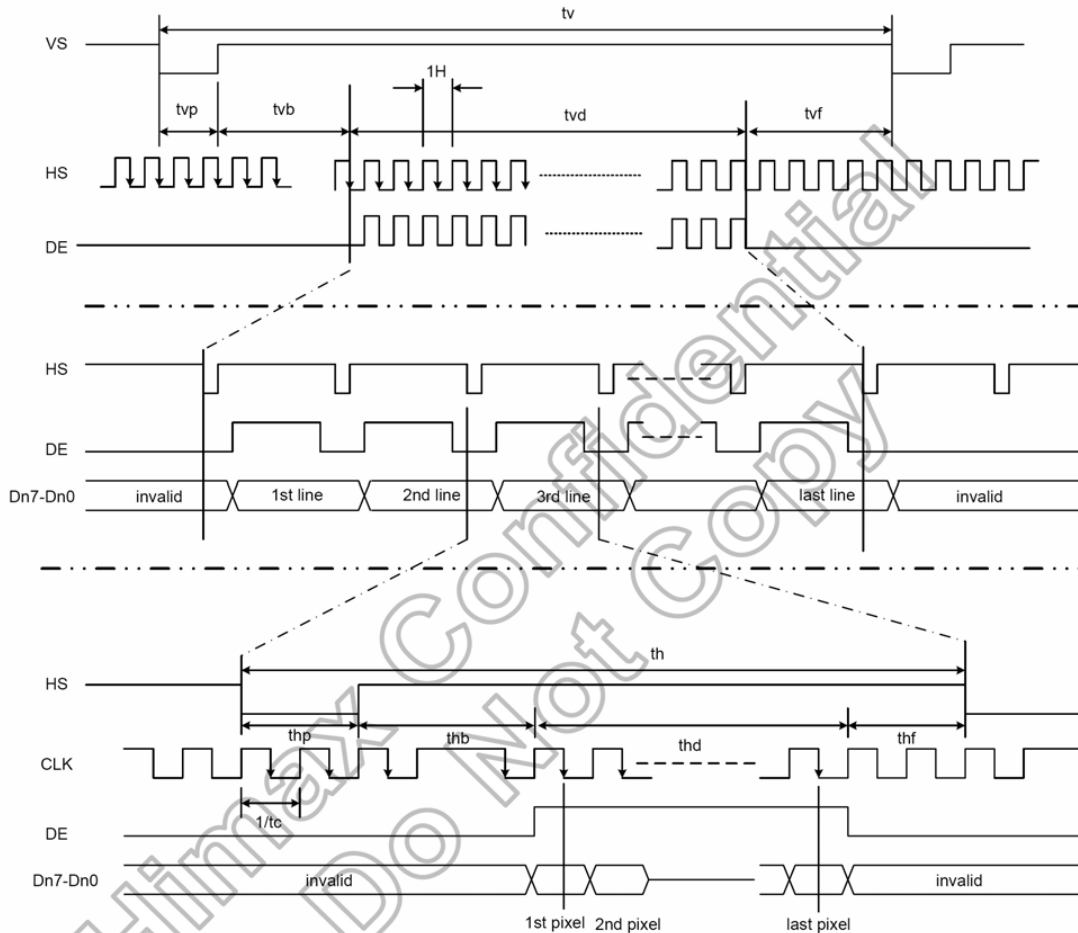



Product Specification	Model:	AWY-480272T43PC05	Rev. No.	Issued Date.	Page.
			A	2015/01/22	16/26

11.3 Power On/Off

Sequence power on

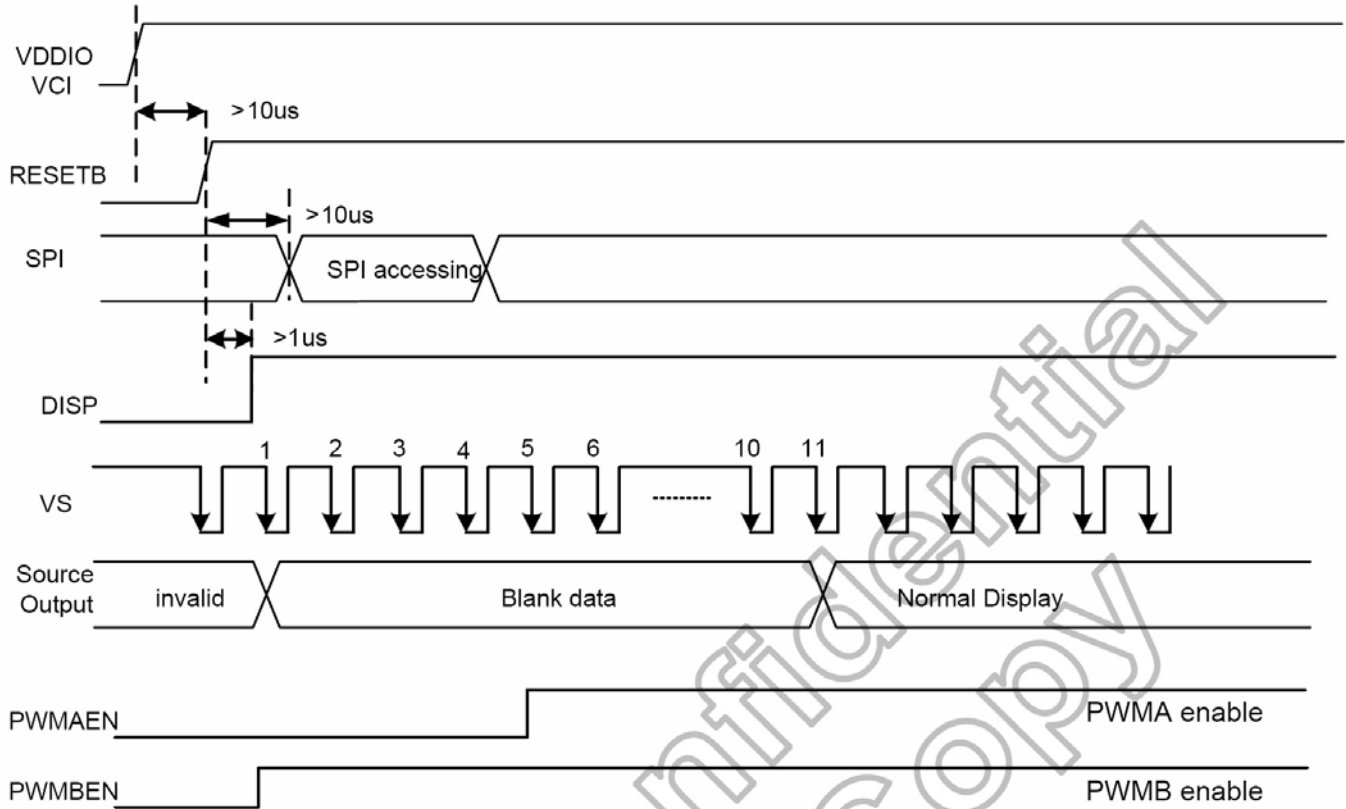

Power off

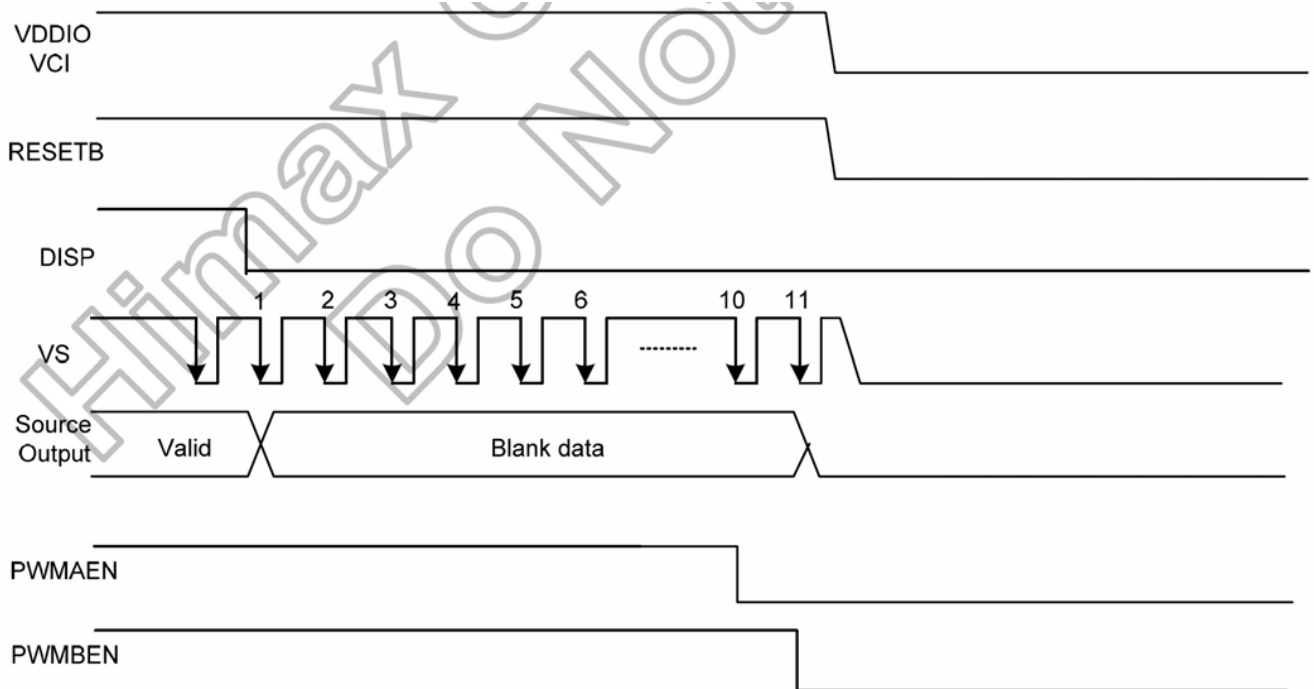



Product Specification	Model:	AWY-480272T43PC05	Rev. No.	Issued Date.	Page.
			A	2015/01/22	17/26

12. Driver ic control algorithms

Refer to the data Sheet of LCD DRIVER HX8257A

13. Reliability test items

No.	Test items	Conditions	Remark
1	High temperature operation	70°C , 240hours	--
2	Low temperature operation	-20°C , 240hours	--
3	High temperature storage	80°C , 240hours	
4	Low temperature storage	-30°C , 240hours	
5	High temperature & high humidity storage	60°C , 90% RH , 240hours	--
6	Thermal Shock storage	-20°C , 30min. ~ 70°C , 30min. , 100 Cycles	--
7	Vibration test	Freq.:10~55~10~55~10 Hz, Amplitude : 1.5 mm. 2 hours for each direction of X, Y, Z	Non-operation
8	Electrostatic discharge	±2KV, Human Body Mode, 100pF / 1500Ω	Non-operation

Criterion: There should be no change which might affect the practical display function when the display quality test is conducted under normal operating condition.



Product Specification	Model:	AWY-480272T43PC05	Rev. No.	Issued Date.	Page.
			A	2015/01/22	18/26

14. Quality assurance

14.1 Purpose

This standard for Quality Assurance assures the quality of LCD module products supplied to customer

14.2 Agreement items

Customer shall negotiate if the following situation occurs:

14.2.1 Discrepancies between Palm Tech's QA standards and customer's QA standards.

14.2.2 Additional requirement to be added in product specification.

14.2.3 Any other special problem.

14.3 Standard of the product visual inspection

14.3.1 Appearance inspection:

14.3.1.1 The inspection must be under illumination about 1000 – 1500 lx, and the distance of view must be at 30cm ± 2cm.

14.3.1.2 The viewing angle should be 45° from the vertical line without reflection light or follows customer's viewing angle specifications.

14.3.1.3 Definition of area: A Zone: Active Area, B Zone: Viewing Area,

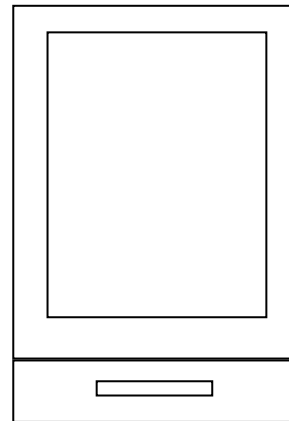
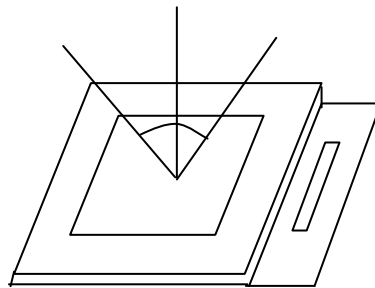

14.3.2 Basic principle:

14.3.2.1 A set of sample to indicate the limit of acceptable quality level must be discussed by when there is any dispute happened.



Product Specification	Model:	AWY-480272T43PC05	Rev. No.	Issued Date.	Page.
			A	2015/01/22	19/26

14.4 Inspection specification

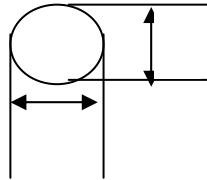
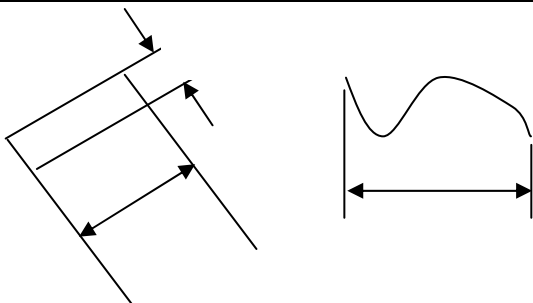
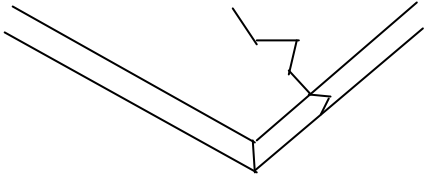
No.	Item	Criteria (Unit: mm)																		
01	Black / White spot Foreign material (Round type) Pinholes Stain Particles inside cell. (Minor defect)	 $\phi = (a + b) / 2$ <table border="1" data-bbox="898 414 1401 721"> <thead> <tr> <th>Size</th> <th>Area</th> <th>Acc. Qty</th> </tr> </thead> <tbody> <tr> <td>$\phi \leq 0.10$</td> <td></td> <td>Ignore</td> </tr> <tr> <td>$0.10 < \phi \leq 0.20$</td> <td></td> <td>2</td> </tr> <tr> <td>$0.20 < \phi \leq 0.25$</td> <td></td> <td>1</td> </tr> <tr> <td>$0.25 < \phi$</td> <td></td> <td>0</td> </tr> <tr> <td>Total</td> <td></td> <td>2 no include $\phi \leq 0.10$</td> </tr> </tbody> </table> <p>Distance between 2 defects should more than 3mm apart.</p>	Size	Area	Acc. Qty	$\phi \leq 0.10$		Ignore	$0.10 < \phi \leq 0.20$		2	$0.20 < \phi \leq 0.25$		1	$0.25 < \phi$		0	Total		2 no include $\phi \leq 0.10$
Size	Area	Acc. Qty																		
$\phi \leq 0.10$		Ignore																		
$0.10 < \phi \leq 0.20$		2																		
$0.20 < \phi \leq 0.25$		1																		
$0.25 < \phi$		0																		
Total		2 no include $\phi \leq 0.10$																		
02	Black and White line Scratch Foreign material (Line type) (Minor defect)	 <table border="1" data-bbox="625 1086 1252 1344"> <thead> <tr> <th>Length</th> <th>Width</th> <th>Acc. Qty</th> </tr> </thead> <tbody> <tr> <td>/</td> <td>$W \leq 0.03$</td> <td>Ignore</td> </tr> <tr> <td>$L \leq 2$</td> <td>$0.03 < W \leq 0.05$</td> <td>1</td> </tr> <tr> <td>/</td> <td>$0.05 < W$</td> <td>0</td> </tr> <tr> <td colspan="2">Total</td> <td>1</td> </tr> </tbody> </table> <p>Distance between 2 defects should more than 3mm apart. Scratches not viewable through the back of the display are acceptable.</p>	Length	Width	Acc. Qty	/	$W \leq 0.03$	Ignore	$L \leq 2$	$0.03 < W \leq 0.05$	1	/	$0.05 < W$	0	Total		1			
Length	Width	Acc. Qty																		
/	$W \leq 0.03$	Ignore																		
$L \leq 2$	$0.03 < W \leq 0.05$	1																		
/	$0.05 < W$	0																		
Total		1																		
03	Glass Crack (Minor defect)	 <p>LCD with extensible crack line is unacceptable(When press the cracked LCD area, the line will expand, we define it is extensible crack line)</p>																		



Product Specification	Model:	AWY-480272T43PC05	Rev. No.	Issued Date.	Page.
			A	2015/01/22	20/26

04	<p>FPC Defect: (Minor defect)</p>	<p>9.1 Dent, pinhole width $a < w/3$. (w: circuitry width.)</p> <p>9.2 Open circuit is unacceptable.</p> <p>9.3 No oxidation, contamination and distortion.</p>								
05	Bubble on Polarizer (Minor defect)	<table border="1"> <thead> <tr> <th>Diameter</th> <th>Acc. Qty</th> </tr> </thead> <tbody> <tr> <td>$\phi \leq 0.20$</td> <td>Ignore</td> </tr> <tr> <td>$0.20 < \phi \leq 0.30$</td> <td>2</td> </tr> <tr> <td>$0.30 < \phi$</td> <td>None</td> </tr> </tbody> </table>	Diameter	Acc. Qty	$\phi \leq 0.20$	Ignore	$0.20 < \phi \leq 0.30$	2	$0.30 < \phi$	None
Diameter	Acc. Qty									
$\phi \leq 0.20$	Ignore									
$0.20 < \phi \leq 0.30$	2									
$0.30 < \phi$	None									
06	Dent on Polarizer (Minor defect)	<table border="1"> <thead> <tr> <th>Diameter</th> <th>Acc. Qty</th> </tr> </thead> <tbody> <tr> <td>$\phi \leq 0.20$</td> <td>Ignore</td> </tr> <tr> <td>$0.20 < \phi \leq 0.30$</td> <td>2</td> </tr> <tr> <td>$0.30 < \phi$</td> <td>None</td> </tr> </tbody> </table>	Diameter	Acc. Qty	$\phi \leq 0.20$	Ignore	$0.20 < \phi \leq 0.30$	2	$0.30 < \phi$	None
Diameter	Acc. Qty									
$\phi \leq 0.20$	Ignore									
$0.20 < \phi \leq 0.30$	2									
$0.30 < \phi$	None									
07	Bezel	<p>12.1 No rust, distortion on the Bezel.</p> <p>12.2 No visible fingerprints, stains or other contamination.</p>								
08	Touch Panel	<p>D: Diameter W: width L: length</p> <p>13.1 Spot: $D \leq 0.20$ is acceptable $0.20 < D \leq 0.3$, acceptable QTY, 3</p> <p>2dots are acceptable and the distance between defects should more than 10 mm.</p> <p>$D > 0.3$ is unacceptable</p> <p>13.2 Dent: $D > 0.30$ is unacceptable</p> <p>13.3 Scratch: $W \leq 0.03$, $L \leq 10$ is acceptable, $0.03 < W \leq 0.10$, $L \leq 10$, acceptable QTY, 3</p> <p>Distance between 2 defects should more than 10 mm.</p> <p>$W > 0.10$ is unacceptable.</p>								
09	PCB	<p>14.1 No distortion or contamination on PCB terminals.</p> <p>14.2 All components on PCB must same as documented on the BOM/component layout.</p> <p>14.3 Follow IPC-A-600F.</p>								
10	Soldering	Follow IPC-A-610C standard								



Product Specification	Model:	AWY-480272T43PC05	Rev. No.	Issued Date.	Page.
			A	2015/01/22	21/26

11	Electrical Defect (Major defect)	<p>The below defects must be rejected.</p> <p>16.1 Missing vertical / horizontal segment, 16.2 Abnormal Display. 16.3 No function or no display. 16.4 Current exceeds product specifications. 16.5 LCD viewing angle defect. 16.6 No Backlight. 16.7 Dark Backlight. 16.8 Touch Panel no function. 16.9 Dark Dot –one Allowed. 16.10 Bright Dot – one Allowed.</p> <p>Remark:</p> <p>1. A pixel defect is acceptable if one color is none functional and causes a bright dot. The display may have one case where one color is out and cause a dark dot. 2. Bright dot caused by scratch and foreign object accords to item 1.</p>
----	-------------------------------------	--

Remark: Visual and cosmetic defects are reject only if these fall within the LCD viewing area.

14.5 Classification of defects

12.5.1 Visual defects (Except no / wrong label) are treated as minor defect and electrical defect is major.

12.5.2 Two minor defects are equal to one major in lot sampling inspection.

14.6 Identification/marking criteria

Any unit with illegible / wrong /double or no marking/ label shall be rejected.

14.7 Packing

12.7.1 There should be no damage of the outside carton box, each packaging box should has label in the correct location per packing drawing requirement.

12.7.2 All direct package materials shall offer ESD protection.

15. Generalprecautions

Please pay attentions to the followings as using the LCD module.

15.1 Handling

- (a) Do not apply strong mechanical stress like drop, shock or any force to LCD module. It may cause improper operation, even damage.
- (b) Because the polarizer is very fragile and easy to be damaged, do not hit, press or rub the display surface with hard materials.
- (c) Do not put heavy or hard material on the display surface, and do not stack LCD modules.
- (d) If the display surface is dirty, please wipe the surface softly with cotton



Product Specification	Model:	AWY-480272T43PC05	Rev. No.	Issued Date.	Page.
			A	2015/01/22	22/26

- (e) swab or clean cloth.
- (f) Avoid using Ketone type materials (e.g. Acetone), Toluene, Ethyl acid or Methyl chloride to clean the display surface. It might damage the polarizer permanently. The recommended solvents are water and Isopropyl alcohol.
- (g) Wipe off water droplets or oil immediately.
- (h) Protect the LCD module from ESD. It will damage the LSI and the electronic circuit.
- (i) Do not touch the output pins directly with bare hands.
- (I) Do not disassemble the LCD module.

15.2 Storage

- (a) Do not leave the LCD modules in high temperature, especially in high humidity for a long time.
- (b) Do not expose the LCD modules to sunlight directly.
- (c) The liquid crystal is deteriorated by ultraviolet. Do not leave it in strong ultraviolet ray for a long time.
- (d) Avoid condensation of water. It may cause improper operation.
- (e) Please stack only up to the number stated on carton box for storage and transportation. Excessive weight will cause deformation and damage of carton box.

15.3 Operation

- (a) When mounting or dismounting the LCD modules, turn the power off.
- (b) Protect the LCD modules from electric shock.
- (c) The Driver IC control algorithms should always obeyed to avoid damaging the LSI and electronic circuit.
- (d) Be careful to avoid mixing up the polarity of power supply for backlight.
- (e) Absolute maximum rating specified above has to be always kept in any case. Exceeding it may cause non-recoverable damage of electronic components or, nevertheless, burning.
- (f) When a static image is displayed for a long time, remnant image is likely to occur.
- (g) Be sure to avoid bending the FPC to an acute shape, it might break FPC.

15.4 Others



<i>Product Specification</i>	<i>Model:</i>	AWY-480272T43PC05	<i>Rev. No.</i>	<i>Issued Date.</i>	<i>Page.</i>
			A	2015/01/22	23/26

- (a) If the liquid crystal leaks from the panel, it should be kept away from the eyes or mouth.
- (b) For the fragility of polarizer, it is recommended to attach a transparent protective plate over the display surface.
- (c) It is recommended to peel off the protection film on the polarizer slowly so that the electrostatic charge can be minimized.



Product Specification	Model:	AWY-480272T43PC05	Rev. No.	Issued Date.	Page.
			A	2015/01/22	24/26

TOUCH PANEL MODULE

1. Basic features

1.1 Dimension

Item	Specification	Remark
Outside Dimension	105.14±0.1mm x 66.21±0.1mm	
View Area	95.84±0.1mm x 54.66±0.1mm	-refer to Artwork
Active Area	96.84 x 55.66mm	w/o Icon
Product Thickness	1.4± 0.1mm	w/i Adhesive
Input Method	Finger	
Hardness of Surface	≥6H	JIS-K5600

1.2 Part. material description

Item	Dimension
PANEL	GLASS
OCA/LOCA	LOCA
IC	FT5306

2. Electrical characteristics

No.	Item	Symbol	Specification			Unit	Remark	
			Min.	Typ.	Max.			
1	Interface	--	I2C			--	--	
2	Power Supply	V _{VDD}	2.5	3.3	3.6	V		
3	Input Signal Voltage	H Level	V _{IH}	1	--	--	V	(MSG21XXA) SCL,SDA, EN
		L Level	V _{IL}	--	--	0.3	V	--
4	Output Signal Voltage	H Level	V _{OH}	V _{VDD} -0.5	--	--	V	--
		L Level	V _{OL}	--	--	0.4	V	--
5	Supply Current	I _{CI}	--	7	25	mA	V _{CI} =3.0V	
6	Report Rate	--	60			Hz		
7	Linearity	--	--	--	+/-2.5	mm	Center Area (4mm aside VA border)	
8	Firmware Version	--	--	--	--	--	V1.18	



Product Specification	Model:	AWY-480272T43PC05	Rev. No.	Issued Date.	Page.
			A	2015/01/22	25/26

3. Optical characteristics

No.	Item	Specification	Remark
1	Transmittance	85% (Typ)	

4. Interface diagram

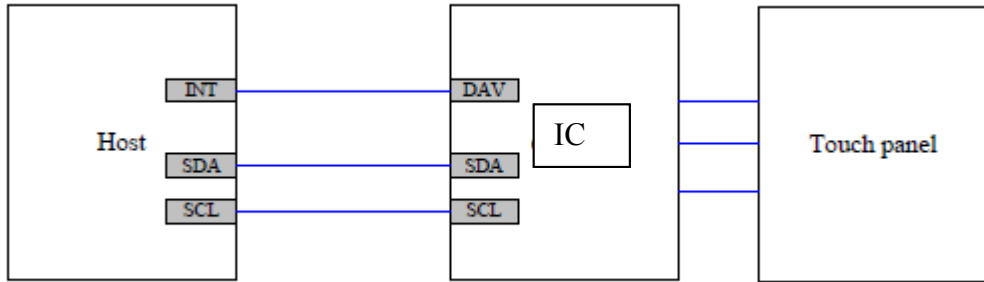

5. Cosmetic testing condition

5.1 Mechanical characteristics

- 5.1.1 Flexible pattern heat seal peeling strength
Peeling Force 90°
Pulling (>500gf/cm).
- 5.1.2 Flexible pattern bending resistance
Φ=3mm Bending 180° 20cycles
- 5.1.3 Ball drop test
>0.2J, 65g at 30cm drop

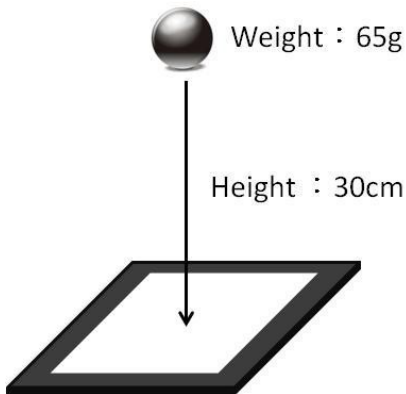



<i>Product Specification</i>	<i>Model:</i>	AWY-480272T43PC05	<i>Rev. No.</i>	<i>Issued Date.</i>	<i>Page.</i>
			A	2015/01/22	26/26

6. Environmental characteristic

Item	Condition	Specification
High Temperature test	60°C , 240hours	No bubble, no vapor, electrical function OK.
Low Temperature test	-20°C , 240hours	
High Temperature / Humidity test	50°C , 90%RH , 240hours	

7. Pin assignments

Pin Name	Define
Pin1	NC
Pin2	NC
Pin3	RST
Pin4	GND
Pin5	INT
Pin6	SDA(2.8V)
Pin7	SCL(2.8V)
Pin8	GND
Pin9	GND
Pin10	VDD(2.8V)



Компания «ЭлектроПласт» предлагает заключение долгосрочных отношений при поставках импортных электронных компонентов на взаимовыгодных условиях!

Наши преимущества:

- Оперативные поставки широкого спектра электронных компонентов отечественного и импортного производства напрямую от производителей и с крупнейших мировых складов;
- Поставка более 17-ти миллионов наименований электронных компонентов;
- Поставка сложных, дефицитных, либо снятых с производства позиций;
- Оперативные сроки поставки под заказ (от 5 рабочих дней);
- Экспресс доставка в любую точку России;
- Техническая поддержка проекта, помощь в подборе аналогов, поставка прототипов;
- Система менеджмента качества сертифицирована по Международному стандарту ISO 9001;
- Лицензия ФСБ на осуществление работ с использованием сведений, составляющих государственную тайну;
- Поставка специализированных компонентов (Xilinx, Altera, Analog Devices, Intersil, Interpoint, Microsemi, Aeroflex, Peregrine, Syfer, Eurofarad, Texas Instrument, Miteq, Cobham, E2V, MA-COM, Hittite, Mini-Circuits, General Dynamics и др.);

Помимо этого, одним из направлений компании «ЭлектроПласт» является направление «Источники питания». Мы предлагаем Вам помощь Конструкторского отдела:

- Подбор оптимального решения, техническое обоснование при выборе компонента;
- Подбор аналогов;
- Консультации по применению компонента;
- Поставка образцов и прототипов;
- Техническая поддержка проекта;
- Защита от снятия компонента с производства.



Как с нами связаться

Телефон: 8 (812) 309 58 32 (многоканальный)

Факс: 8 (812) 320-02-42

Электронная почта: org@eplast1.ru

Адрес: 198099, г. Санкт-Петербург, ул. Калинина, дом 2, корпус 4, литера А.