

## AVO100-36S3V3B-6L

100 Watts

Eighth-brick Converter

**Total Power:** 100 Watts  
**Input Voltage:** 18 to 75 Vdc  
**# of Outputs:** Single

### Special Features

- Delivering up to 30A output
- Ultra-high efficiency 92% typ. at full load
- Wide input range: 18V ~ 75V
- Excellent thermal performance
- No minimum load requirement
- Start-up and shut-down monotonically into any normal and pre-biased loads, internal pre-bias function circuit prevents back negative current drawn from external load
- RoHS 6 compliant
- Remote control function
- Remote output sense
- Trim function: 80% ~ 110%
- Input under voltage lockout
- Output over current protection
- Output over voltage protection
- Over temperature protection
- Industry standard eighth-brick pin-out outline
- Open frame
- Baseplate
- Pin length Option: 3.8mm

### Safety

IEC/EN 60950-1  
UL/TUV  
GB4943  
CE Marking  
EN55022 Class A

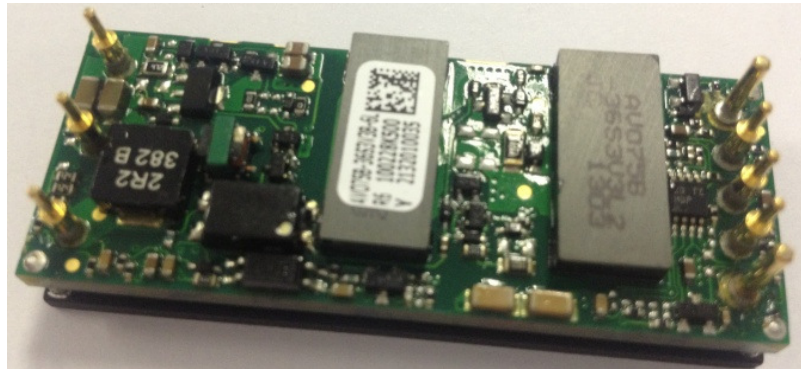

### Product Descriptions

The AVO100-36S3V3B-6L is a single output DC/DC converter with standard eighth-brick form factor and pin configuration. It delivers up to 30A output current with 3.3V output. Ultra-high 92% efficiency and excellent thermal performance makes it an ideal choice for use in computing and telecommunication applications and can operate over an ambient temperature range of -40 °C ~ +85 °C.

### Applications

Telecom/ Datacom

## Model Numbers

Standard	Output Voltage	Structure	Remote ON/OFF logic	RoHS Status
AVO100-36S3V3B-6L	3.3Vdc	Baseplate	Negative	R6

## Ordering information

AVO100	-	36	S	3V3	P	B	-	6	L
①		②	③	④	⑤	⑥		⑦	⑧

①	Model series	AVO: high efficiency eighth brick series, 100: output power 100W
②	Input voltage	36: 18V ~ 75V input range, rated input voltage 36V
③	Output number	S: single output
④	Rated output voltage	3v3: 3.3V output
⑤	Remote ON/OFF logic	Default: negative logic; P: positive logic
⑥	Baseplate status	B: with baseplate; default: open frame
⑦	Pin length	6: 3.8mm
⑧	RoHS status	Y: RoHS, R5; L: RoHS, R6

## Options

None

## Electrical Specifications

### Absolute Maximum Ratings

Stress in excess of those listed in the “Absolute Maximum Ratings” may cause permanent damage to the power supply. These are stress ratings only and functional operation of the unit is not implied at these or any other conditions above those given in the operational sections of this TRN. Exposure to any absolute maximum rated condition for extended periods may adversely affect the power supply’s reliability.

Table 1. Absolute Maximum Ratings:

Parameter	Model	Symbol	Min	Typ	Max	Unit
Input Voltage Operating -Continuous Non-operating -100mS	All	$V_{IN,DC}$	-	-	80	Vdc
	All		-	-	100	Vdc
Maximum Output Power	All	$P_{O,max}$	-	-	100	W
Isolation Voltage <sup>1</sup> Input to outputs input to metal output to metal	Baseplate module		-	-	1500	Vdc
			-	-	1000	
			-	-	1000	
Ambient Operating Temperature	All	$T_A$	-40	-	+85	°C
Storage Temperature	All	$T_{STG}$	-55	-	+125	°C
Voltage at remote ON/OFF pin	All		-0.7	-	12	Vdc

Note 1 - 1mA for 60s, slew rate of 1500V/10s.

## Input Specifications

Table 2. Input Specifications:

Parameter	Conditions	Symbol	Min	Typ	Max	Unit
Operating Input Voltage, DC	All	$V_{IN,DC}$	18	36	75	Vdc
Turn-on Voltage Threshold	$I_O = I_{O,max}$	$V_{IN,ON}$	16.6	17	18	Vdc
Turn-off Voltage Threshold	$I_O = I_{O,max}$	$V_{IN,OFF}$	15.2	16	16.6	Vdc
Lockout Voltage Hysteresis	$I_O = I_{O,max}$		1	-	3	V
Maximum Input Current ( $I_O = I_{O,max}$ )	$V_{IN,DC} = 18V_{DC}$	$I_{IN,max}$	-	-	7	A
No-load Input Current ( $V_O$ On, $I_O = 0A$ )	$V_{IN,DC} = 18V_{DC}$	$I_{IN,no\_load}$	-	0.1	-	A
Standby Input Current ( $V_O$ Off, $I_O = 0A$ )	$V_{IN,DC} = 18V_{DC}$	$I_{IN,no\_load}$	-	-	0.015	A
Inrush Current Transient Rating	All		-	-	1.5	A <sup>2</sup> s
Input Reflected Ripple Current	Through 12 $\mu$ H inductor		-	15	-	mA
Recommended Input Fuse	Fast blow external fuse recommended		-	-	12	A
Input filter component values (C\L)	Internal values		-	2\2.2	-	$\mu$ F\ $\mu$ H
Recommended external input capacitance	All		-	100	-	$\mu$ F
Operating Efficiency	$T_A = 25^\circ C$ $I_O = I_{O,max}$ $I_O = 50\%I_{O,max}$	$\eta$	-	91	-	%
			-	92	-	%

## Output Specifications

Table 3. Output Specifications:

Parameter	Condition	Symbol	Min	Typ	Max	Unit	
Factory Set Voltage	$V_{IN,DC} = 36V_{DC}$ $I_O = I_{O,max}$	$V_O$	3.25	3.3	3.35	Vdc	
Total Regulation	Inclusive of line, load temperature change, warm-up drift	$V_O$	3.2	3.3	3.4	Vdc	
Output Voltage Line Regulation	All	$\%V_O$	-	0.1	0.3	%	
Output Voltage Load Regulation	All	$\%V_O$	-	0.1	0.6	%	
Output Voltage Temperature Regulation	All	$\%V_O$	-	-	0.02	$\%/^{\circ}C$	
Output Voltage Trim Range	All	$V_O$	2.64	-	3.63	V	
Output Ripple, pk-pk	Measure with a 1uF ceramic capacitor in parallel with a 10uF tantalum capacitor, 0 to 20MHz bandwidth	$V_O$	-	60	-	mV <sub>PK-PK</sub>	
Output Current	All	$I_O$	0	-	30	A	
Output DC current-limit inception <sup>1</sup>	All	$I_O$	33	35	40	A	
Vout pre-bias level	All		-	-	75	$\%V_O$	
$V_O$ Load Capacitance <sup>2</sup>	All	$C_O$	220	-	10000	uF	
$V_O$ Dynamic Response	Peak Deviation Settling Time	25% load change slew rate = 0.1A/us	$\pm V_O$	-	70	-	mV
		$T_s$	-	100	-	uSec	
		25% load change slew rate = 1A/us	$\pm V_O$	-	100	-	mV
			$T_s$	-	100	-	uSec
Turn-on transient	Rise time	$I_O = I_{max}$	$T_{rise}$	-	-	50	mS
	Turn-on delay time	$I_O = I_{max}$	$T_{turn-on}$	-	-	30	mS
	Output voltage overshoot	$I_O = 0$	$\%V_O$	-	-	5	%
Switching frequency	All	$f_{sw}$	300	310	320	KHz	
Remote ON/OFF control (positive logic)	Off-state voltage	All		-0.7	-	1.2	V
	On-state voltage	All		3.5	-	12	V

Note 1 - Hiccup: auto-restart when over-current condition is removed.

Note 2 - High frequency and low ESR is recommended.

## Output Specifications

Table 3. Output Specifications, con't:

Parameter		Condition	Symbol	Min	Typ	Max	Unit
Remote ON/OFF control (Negative logic)	Off-state voltage	All		3.5	-	12	V
	On-state voltage	All		-0.7	-	1.2	V
Output voltage remote sense range		All		-	-	0.165	V
Output over-voltage protection <sup>3</sup>		All	V <sub>O</sub>	3.8	-	4.6	V
Output over-temperature protection <sup>4</sup>		All	T	-	110	125	°C
MTBF		Telcordia SR-332 Method 1 Case3; 80% load, 300LFM, 40 °C T <sub>A</sub>		-	1.5	-	10 <sup>6</sup> h

Note 3 - Hiccup: auto-restart when over-voltage condition is removed.

Note 4 - Auto recovery.

## AVO100-36S3V3B-6L Performance Curves

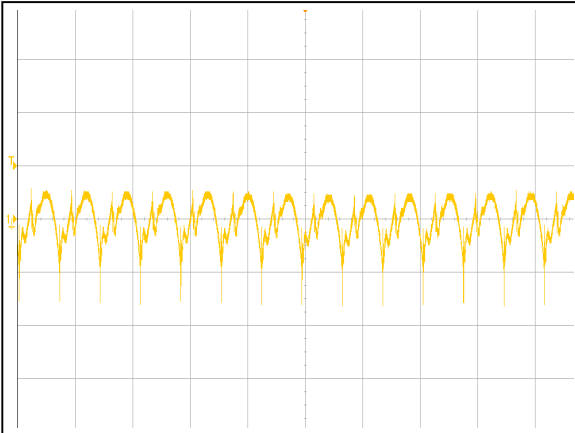

Figure 1: AVO100-36S3V3B-6L Ripple and Noise Measurement  
 Ch 1: Vo (5 $\mu$ s/div, 20mV/div)

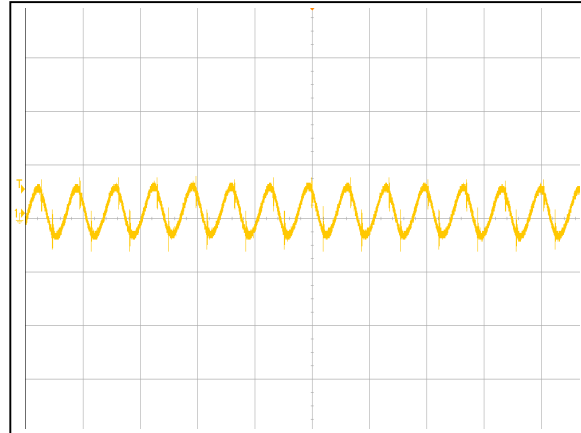

Figure 2: AVO100-36S3V3B-6L Input reflected ripple current  
 Ch 1: Vo (5 $\mu$ s/div, 10mA/div)

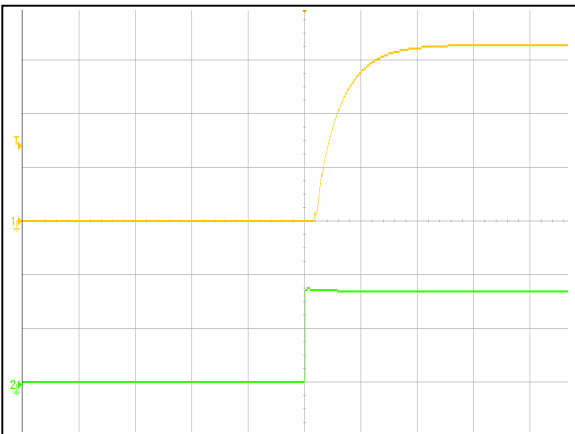

Figure 3: AVO100-36S3V3B-6L Output Voltage Startup Characteristic (50ms/div)  
 Ch 1: Vo (1V/div) Ch 2: Vin (20V/div)

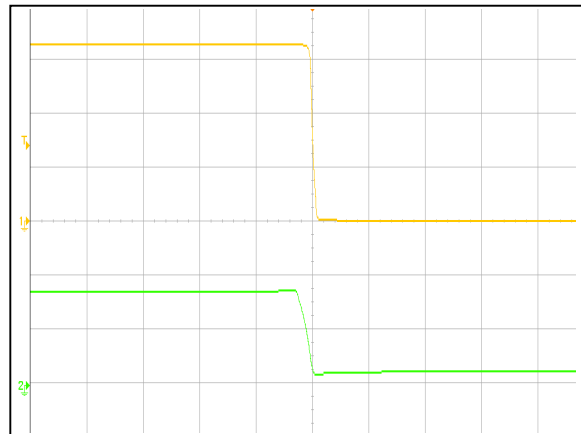

Figure 4: AVO100-36S3V3B-6L Turn Off Characteristic (2mS/div)  
 Ch 1: Vo (1V/div) Ch 2: Vin (20V/div)

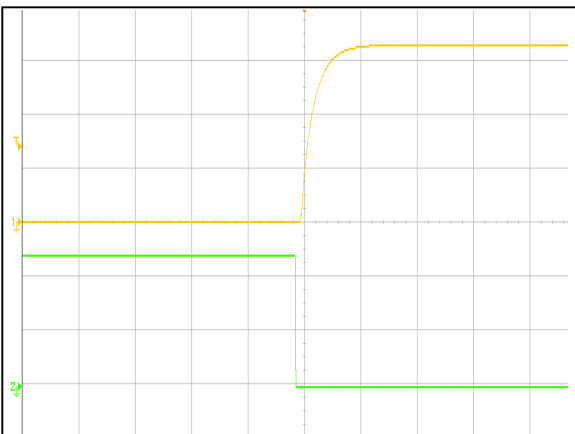

Figure 5: AVO100-36S3V3B-6L Remote ON Waveform (100mS/div)  
 Ch 1: Vo (1V/div) Ch 2: Remote ON (2V/div)

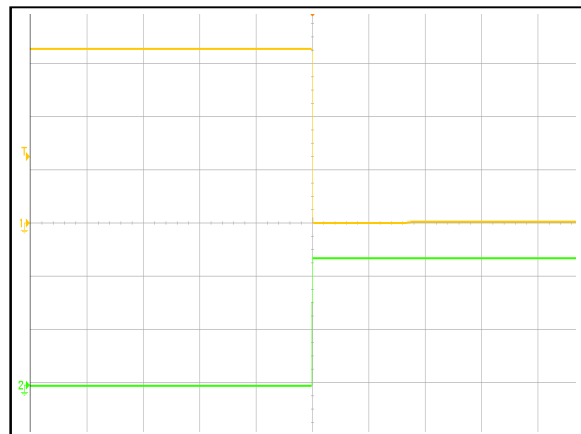

Figure 6: AVO100-36S3V3B-6L Remote OFF Waveform (50mS/div)  
 Ch 1: Vo (1V/div) CH2: Remote OFF (2V/div)

## AVO100-36S3V3B-6L Performance Curves

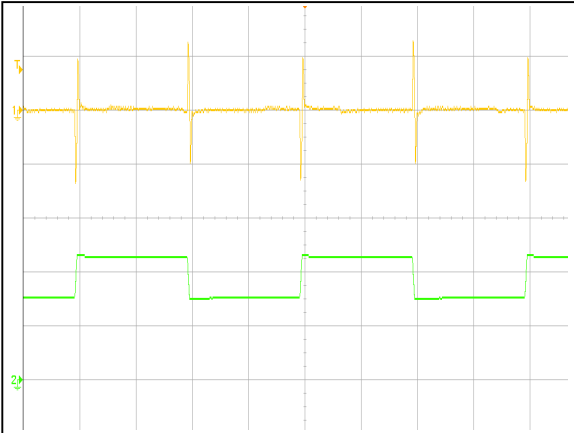

Figure 7: AVO100-36S3V3B-6L Transient Response (2mS/div)  
 50%-75%-50% load change, 0.1A/uS slew rate,  
 Ch 1: Vo (50mV/div) Ch 2: Io (10A/div)

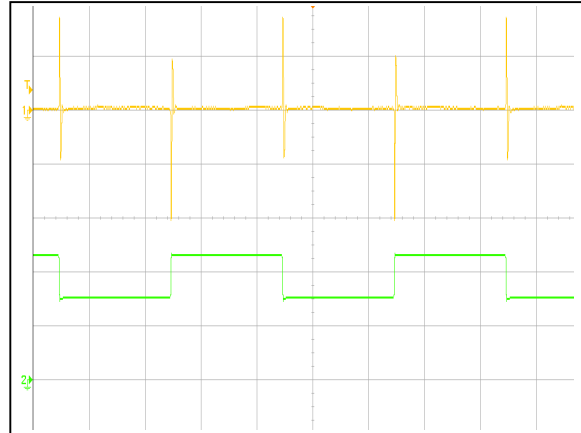

Figure 8: AVO100-36S3V3B-6L Transient Response (2mS/div)  
 50%-75%-50% load change, 1A/uS slew rate,  
 Ch 1: Vo (100mV/div) Ch 2: Io (10A/div)

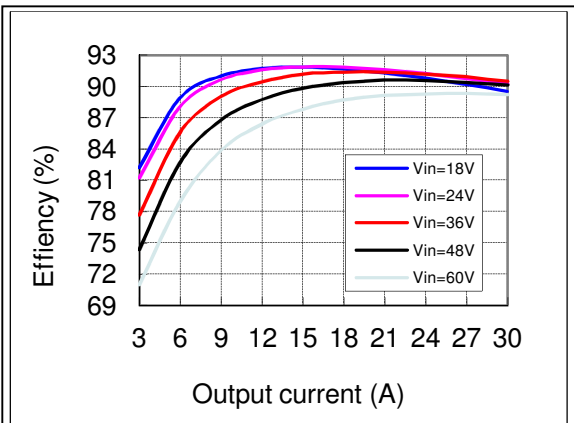

Figure 9: AVO100-36S3V3B-6L Efficiency Curves @ 25 degC

Loading: Io = 10% increment to 30A



## Mechanical Specifications

### Mechanical Outlines – Base plate Module

AVO100-36S3V3B-6L

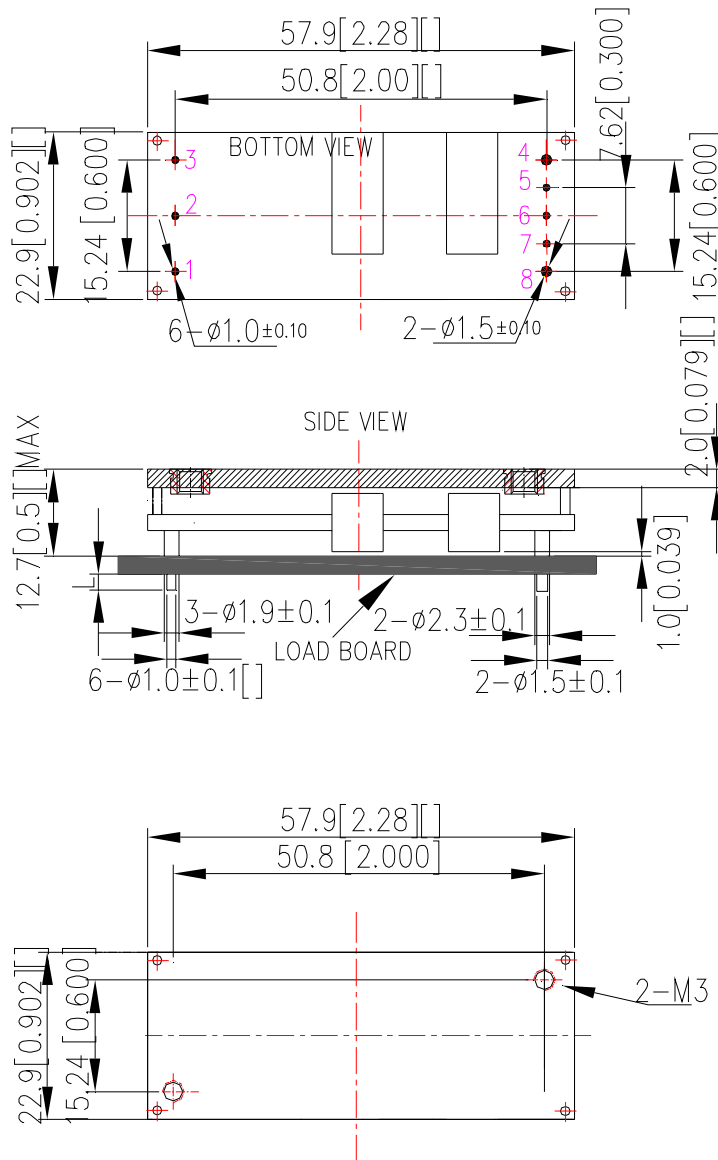

UNIT: mm[inch]

BOTTOM VIEW: pin on upside

TOLERANCE: X.Xmm $\pm$ 0.5mm[X.X in. $\pm$ 0.02in.]

X.XXmm $\pm$ 0.25mm[X.XX in. $\pm$ 0.01in.]

Figure 10 Mechanical diagram

## Pin Length Option

Device code suffix	L
-4	4.8mm ± 0.25mm
-6	3.8mm ± 0.25mm
-8	2.8mm ± 0.25mm
None	5.8mm ± 0.25mm

## Pin Designations

Pin No	Name	Function
1	Vin+	Positive input voltage
2	Remote On/Off	Remote control
3	Vin-	Negative input voltage
4	Vo-	Negative output voltage
5	S-	Negative remote sense
6	Trim	Output voltage trim
7	S+	Positive remote sense
8	Vo+	Positive output voltage

## Environmental Specifications

### EMC Immunity

AVO100-36S3V3B-6L power supply is designed to meet the following EMC immunity specifications:

Table 4. Environmental Specifications:

Document	Description
EN55022, Class A Limits	Conducted and Radiated EMI Limits
IEC/EN 61000-4-2, Level 3	Immunity to Electrostatic Discharge. Enclosure Port
IEC/EN 61000-4-6, Level 2	Immunity to Continuous Conducted Interference. DC input port
IEC/EN 61000-4-4, Level3	Immunity to Electrical Fast Transient
IEC/EN 61000-4-5	Immunity to surges - 600V common mode and 600V differential mode for DC ports
EN61000-4-29	Immunity to Voltage Dips and short interruptions and voltage variations. DC input port

### EMC Test Conditions

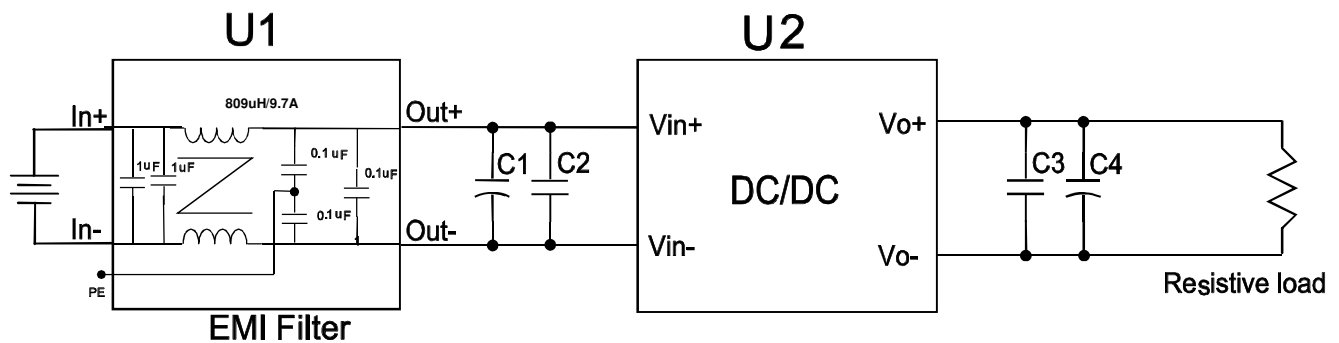

Figure 11 EMC test configuration

U1: Input EMC filter

U2: Module to test, AVO100-36S3V3B

C1 ~ C4: See Figure 18

## **Safety Certifications**

The AVO100-36S3V3B-6L power supply is intended for inclusion in other equipment and the installer must ensure that it is in compliance with all the requirements of the end application. This product is only for inclusion by professional installers within other equipment and must not be operated as a stand alone product.

Table 5. Safety Certifications for AVO100-36S3V3B-6L power supply system

<b>Document</b>	<b>File #</b>	<b>Description</b>
UL/CSA 60950		US and Canada Requirements
EN60950		European Requirements
IEC60950		International Requirements
CE		CE Marking

## Operating Temperature

The AVO100-36S3V3B-6L power supplies will start and operate within stated specifications at an ambient temperature from -40 °C to 85 °C under all load conditions. The storage temperature is -55 °C to 125 °C.

## Thermal Considerations – Baseplate module

The converter is designed to operate in different thermal environments and sufficient cooling must be provided. Proper cooling can be verified by measuring the temperature at the test points as shown in figure 12. The temperature at this point should not exceed the max values in the table 6.

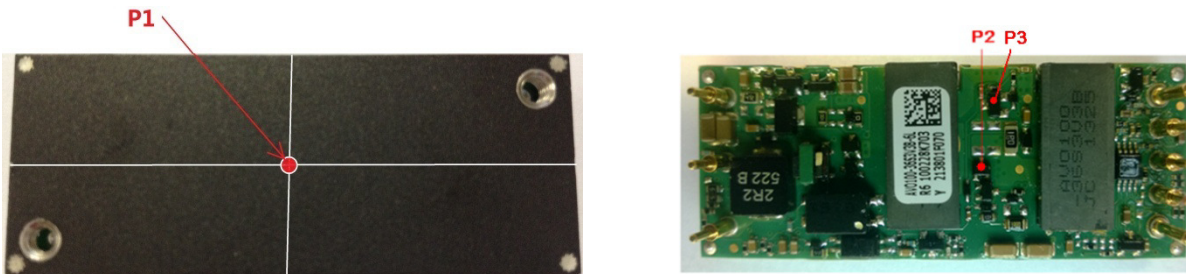

Figure 12 Temperature test point

Table 6 Temperature limit of the test points

Test Point	Temperature limit
P1	105° C
P2	120° C
P3	122° C

The converter can operate with a smaller heatsink and sufficient airflow. Figure 15 and Figure 16 shows the derating output current vs. ambient air temperature at different air velocity with a specified heatsink.

The typical test condition is shown in Figure 13 and Figure 14. Figure 17 shows the thermal image taken by a RF camera at a rated I/O condition.

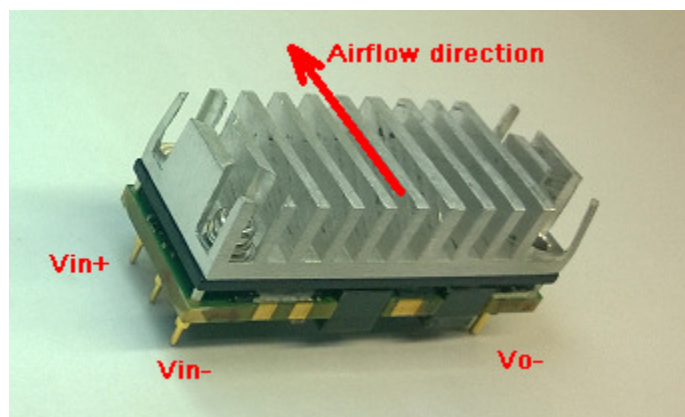

Figure 13 Typical test condition, heatsink size (L\*W\*H): 57.9mm\*22.86\*12.7mm

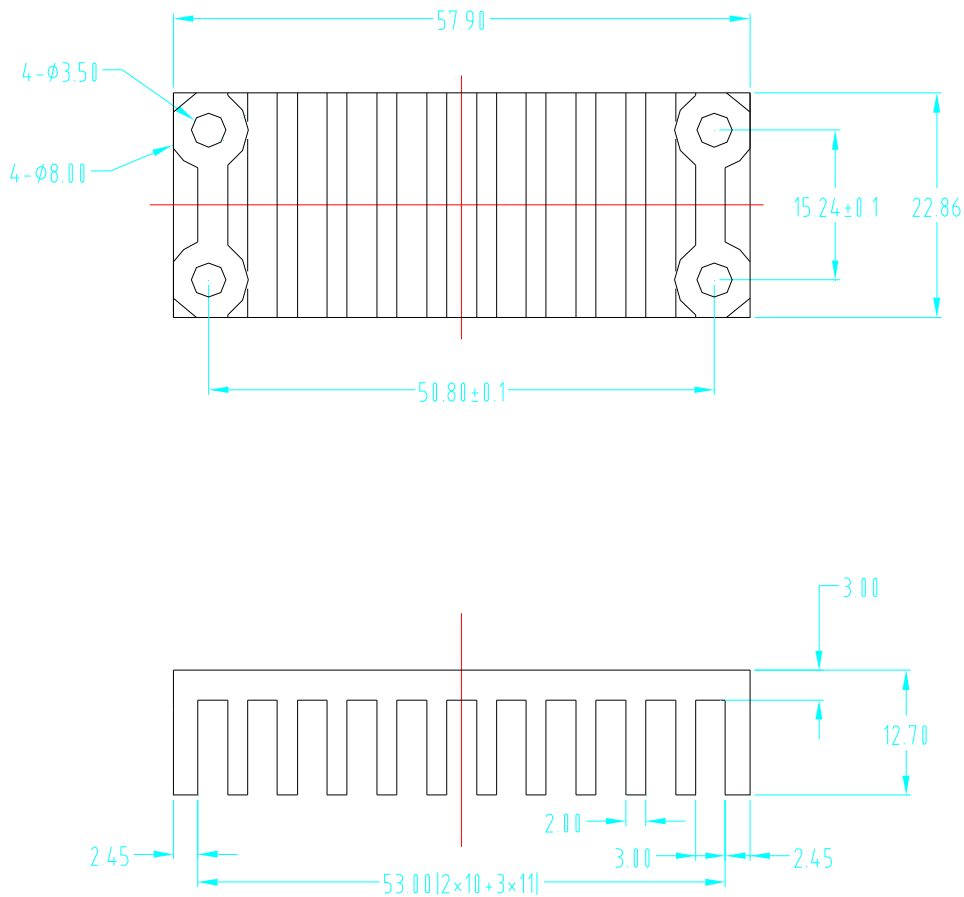

Figure 14 heatsink mechanical diagram

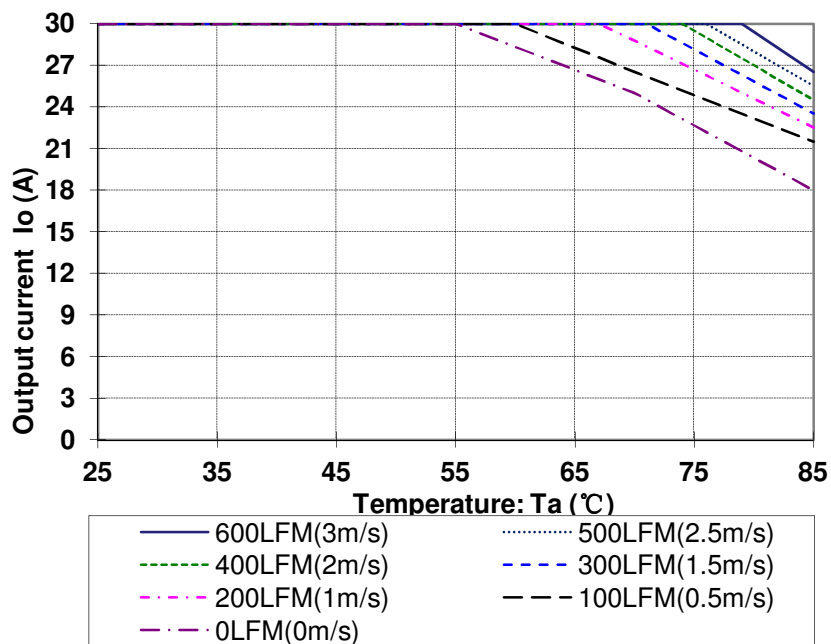

Figure 15 Output power derating, 24V<sub>in</sub>, air flowing across the converter from pin 3 to pin1

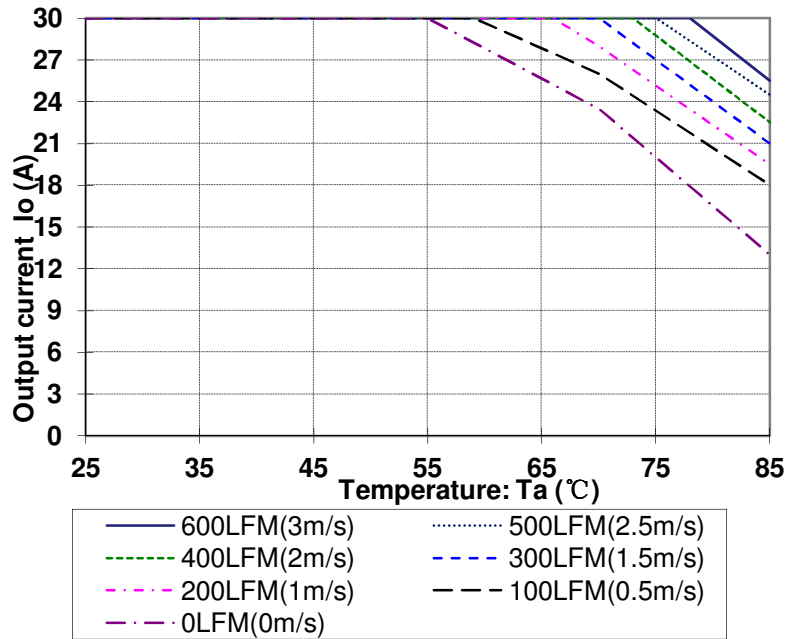

Figure 16 Output power derating,  $48V_{in}$ , air flowing across the converter from pin 3 to pin 1

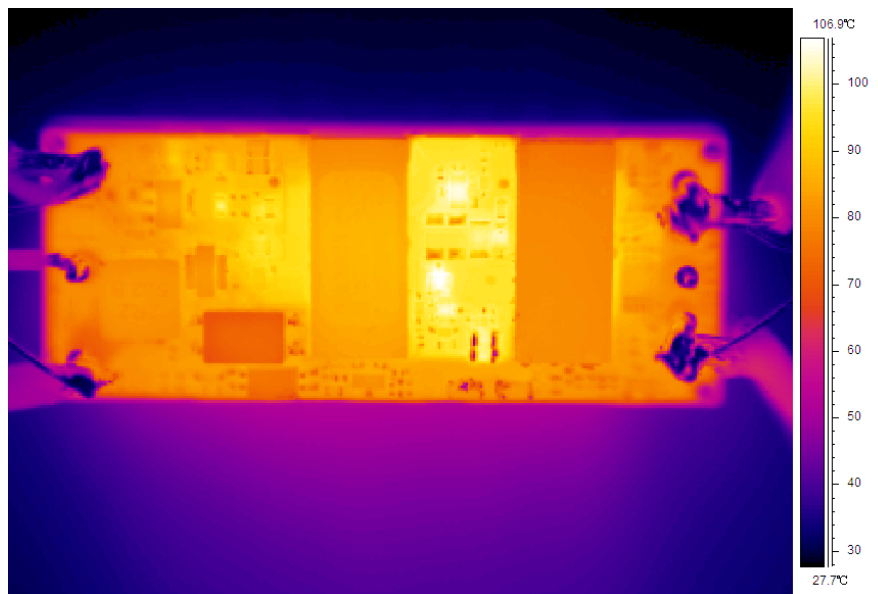

Figure 17 Thermal image,  $36V_{in}$ ,  $3.3V_o$ , full load, room temperature, 100LFM (air flowing from pin 3 to pin 1)

## Qualification Testing

Parameter	Unit (pcs)	Test condition
Halt test	4-5	$T_{a,min} - 10\text{ }^{\circ}\text{C}$ to $T_{a,max} + 25\text{ }^{\circ}\text{C}$ , $10\text{ }^{\circ}\text{C}$ step, $V_{in} = \text{min to max}$ , 0 ~ 100% load
Vibration	3	Frequency range: 5Hz ~ 20Hz, 20Hz ~ 200Hz, A.S.D: $1.0\text{m}^2/\text{s}^3$ , -3db/oct, axes of vibration: X/Y/Z. Time: 30min/axes
Mechanical Shock	3	30g, 6ms, 3axes, 6directions, 3time/direction
Thermal Shock	3	$-40\text{ }^{\circ}\text{C}$ to $100\text{ }^{\circ}\text{C}$ , unit temperature 20cycles
Thermal Cycling	3	$-40\text{ }^{\circ}\text{C}$ to $85\text{ }^{\circ}\text{C}$ , temperature change rate: $1\text{ }^{\circ}\text{C}/\text{min}$ , cycles: 2cycles
Humidity	3	$40\text{ }^{\circ}\text{C}$ , 95%RH, 48h
Solder Ability	15	IPC J-STD-002C-2007



## Application Notes

### Typical Application

Below is the typical application of the AVO100-36S3V3B-6L power supply.

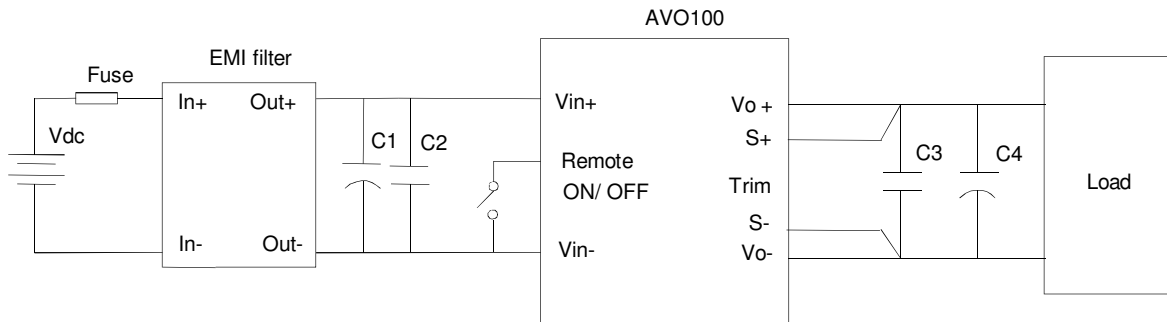

Figure 18 Typical application

C1: 100 $\mu$ F/100V electrolytic capacitor, P/N: UPM2A101MPD (Nichicon) or equivalent caps

C2, C3: 1 $\mu$ F/100V X7R ceramic capacitor, P/N: C3225X7R2A105KT0L0U (TDK) or equivalent caps

C4: 470 $\mu$ F/25V electrolytic capacitor, P/N: UPM1E471MED (Nichicon) or equivalent caps

Note: If ambient temperature is below -5 $^{\circ}$  C, additional 220 $\mu$ F tantalum capacitor (Low ESR, ESR $\leq$ 100m $\Omega$ ) is needed for output.

Fuse: External fast blow fuse with a rating of 10A/250Vac. The recommended fuse model is 0314010.MXP from Littlefuse Far East Pte LTD.

## Remote ON/OFF

Either positive or negative remote ON/OFF logic is available in AVO100-36S3V3B-6L. The logic is CMOS and TTL compatible. Below is the detailed internal circuit and reference in AVO100-36S3V3B-6L.

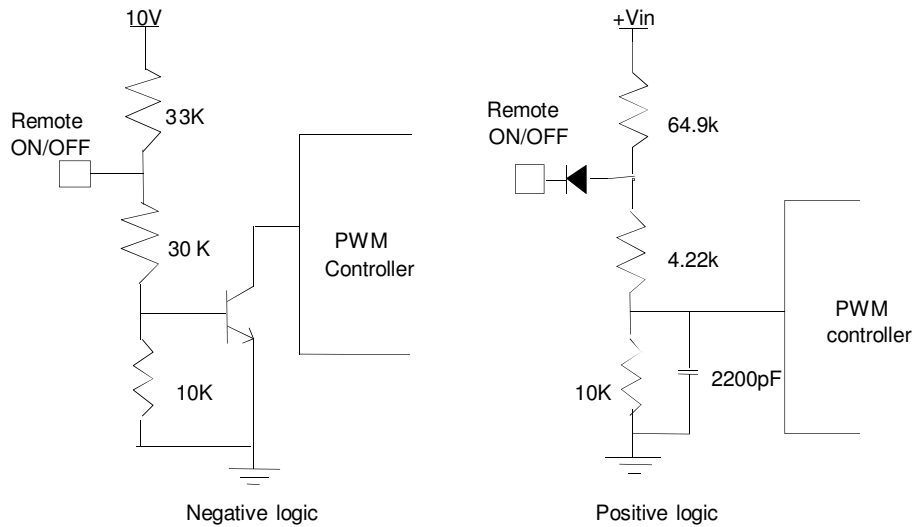

Figure 19 Remote ON/OFF internal diagram

The voltage between pin Remote ON/OFF and pin Vin- must not exceed the range listed in table “Feature characteristics” to ensure proper operation. The external Remote ON/OFF circuit is highly recommended as shown in figure 20.

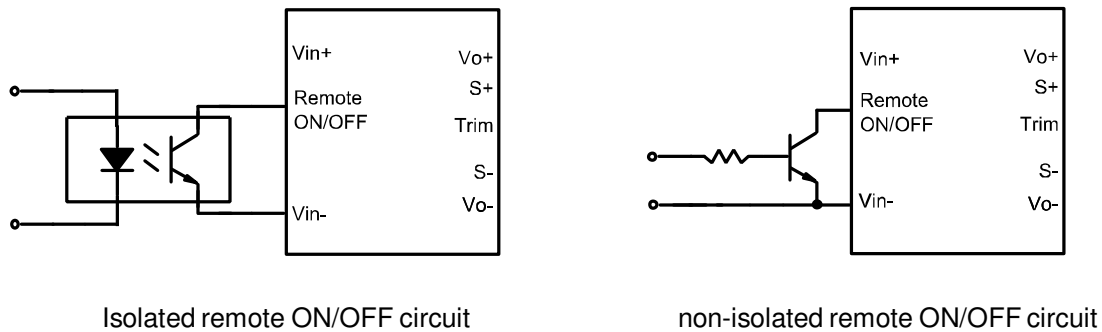

Figure 20 External Remote ON/OFF circuit

## Trim Characteristics

Connecting an external resistor between Trim pin and Vo- pin will decrease the output voltage. While connecting it between Trim and Vo+ will increase the output voltage. The following equations determine the external resistance to obtain the trimmed output voltage.

$$R_{adj-down} = \frac{510}{\Delta} - 10.2(K\Omega)$$

$$R_{adj-up} = \frac{5.1 \times V_{nom} \times (100 + \Delta)}{1.225 \times \Delta} - \frac{510}{\Delta} - 10.2(K\Omega)$$

$\Delta$ : Output error rate against nominal output voltage.

$$\Delta = \frac{100 \times (V_{nom} - V_o)}{V_{nom}}$$

$V_{nom}$ : Nominal output voltage.

For example, to get 3.63V output, the trimming resistor is

$$\Delta = \frac{100 \times (V_{nom} - V_o)}{V_{nom}} = \frac{100 \times (3.63 - 3.3)}{3.3} = 10$$

$$R_{adj-up} = \frac{5.1 \times 3.3 \times (100 + 10)}{1.225 \times 10} - \frac{510}{10} - 10.2 = 89.9(K\Omega)$$

The output voltage can also be trimmed by potential applied at the Trim pin.

$$V_o = (V_{trim} + 1.225) \times 1.347$$

Where  $V_{trim}$  is the potential applied at the Trim pin, and  $V_o$  is the desired output voltage.

When trimming up, the output current should be decreased accordingly so as not to exceed the maximum output power.

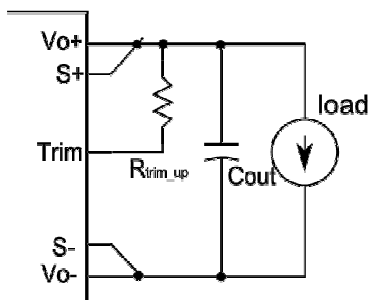

Figure 21 Trim up

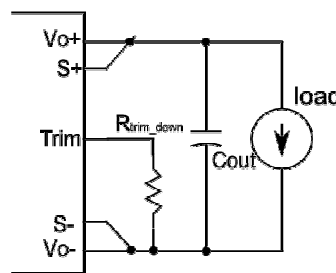

Figure 22 Trim down

**Input Ripple & Output Ripple & Noise Test Configuration**

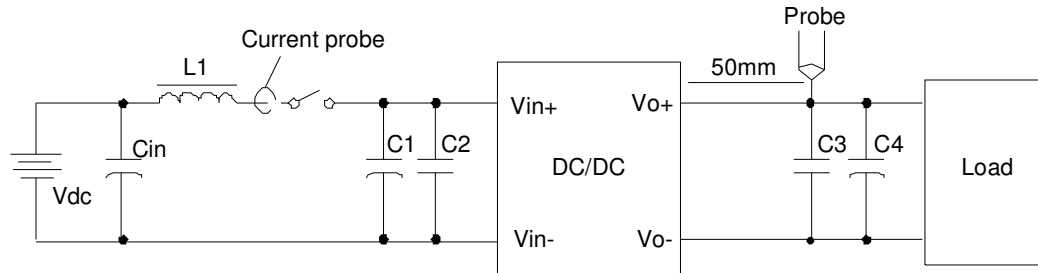

Figure 23 Input ripple & output ripple & noise test configuration

Vdc: DC power supply

L1: 12uH

Cin: 220uF/100V typical

C1 ~ C4: See Figure 18

Note - Using a coaxial cable with series 50ohm resistor and 0.68uF ceramic capacitor or a ground ring of probe to test output ripple & noise is recommended.

### **Sense Characteristics**

If the load is far from the unit, connect S+ and S- to the terminals of the load respectively to compensate the voltage drop on the transmission line. See Figure 18.

If the sense compensation function is not necessary, connect S+ to  $V_{o+}$  and S- to  $V_{o-}$  directly.

### **Soldering**

The product is intended for standard manual or wave soldering.

When wave soldering is used, the temperature on pins is specified to maximum 255 °C for maximum 7s.

When soldering by hand, the iron temperature should be maintained at 300 °C ~ 380 °C and applied to the converter pins for less than 10s. Longer exposure can cause internal damage to the converter.

Cleaning of solder joint can be performed with cleaning solvent IPA or similitive.

**Hazardous Substances Announcement (RoHS of China)**

Parts	Hazardous Substances					
	Pb	Hg	Cd	Cr <sup>6+</sup>	PBB	PBDE
AVO100-36S3V3B-6L	x	x	x	x	x	x

x: Means the content of the hazardous substances in all the average quality materials of the part is within the limits specified in SJ/T-11363-2006

√: Means the content of the hazardous substances in at least one of the average quality materials of the part is outside the limits specified in SJ/T11363-2006

Artesyn Embedded Technologies has been committed to the design and manufacturing of environment-friendly products. It will reduce and eventually eliminate the hazardous substances in the products through unremitting efforts in research. However, limited by the current technical level, the following parts still contain hazardous substances due to the lack of reliable substitute or mature solution:

1. Solders (including high-temperature solder in parts) contain plumbum.
2. Glass of electric parts contains plumbum.
3. Copper alloy of pins contains plumbum

**WORLDWIDE OFFICES**

**Americas**

2900 S.Diablo Way  
 Tempe, AZ 85282  
 USA  
 +1 888 412 7832

**Europe (UK)**

Waterfront Business Park  
 Merry Hill, Dudley  
 West Midlands, DY5 1LX  
 United Kingdom  
 +44 (0) 1384 842 211

**Asia (HK)**

14/F, Lu Plaza  
 2 Wing Yip Street  
 Kwun Tong, Kowloon  
 Hong Kong  
 +852 2176 3333



[www.artesyn.com](http://www.artesyn.com)

While every precaution has been taken to ensure accuracy and completeness in this literature, Artesyn Embedded Technologies assumes no responsibility, and disclaims all liability for damages resulting from use of this information or for any errors or omissions. Artesyn Embedded Technologies, Artesyn and the Artesyn Embedded Technologies logo are trademarks and service marks of Artesyn Technologies, Inc. All other names and logos referred to are trade names, trademarks, or registered trademarks of their respective owners.  
 © 2014 All rights reserved.

For more information: [www.artesyn.com/power](http://www.artesyn.com/power)  
 For support: [productsupport.ep@artesyn.com](mailto:productsupport.ep@artesyn.com)



Компания «ЭлектроПласт» предлагает заключение долгосрочных отношений при поставках импортных электронных компонентов на взаимовыгодных условиях!

Наши преимущества:

- Оперативные поставки широкого спектра электронных компонентов отечественного и импортного производства напрямую от производителей и с крупнейших мировых складов;
- Поставка более 17-ти миллионов наименований электронных компонентов;
- Поставка сложных, дефицитных, либо снятых с производства позиций;
- Оперативные сроки поставки под заказ (от 5 рабочих дней);
- Экспресс доставка в любую точку России;
- Техническая поддержка проекта, помощь в подборе аналогов, поставка прототипов;
- Система менеджмента качества сертифицирована по Международному стандарту ISO 9001;
- Лицензия ФСБ на осуществление работ с использованием сведений, составляющих государственную тайну;
- Поставка специализированных компонентов (Xilinx, Altera, Analog Devices, Intersil, Interpoint, Microsemi, Aeroflex, Peregrine, Syfer, Eurofarad, Texas Instrument, Miteq, Cobham, E2V, MA-COM, Hittite, Mini-Circuits, General Dynamics и др.);

Помимо этого, одним из направлений компании «ЭлектроПласт» является направление «Источники питания». Мы предлагаем Вам помощь Конструкторского отдела:

- Подбор оптимального решения, техническое обоснование при выборе компонента;
- Подбор аналогов;
- Консультации по применению компонента;
- Поставка образцов и прототипов;
- Техническая поддержка проекта;
- Защита от снятия компонента с производства.



#### Как с нами связаться

**Телефон:** 8 (812) 309 58 32 (многоканальный)

**Факс:** 8 (812) 320-02-42

**Электронная почта:** [org@eplast1.ru](mailto:org@eplast1.ru)

**Адрес:** 198099, г. Санкт-Петербург, ул. Калинина, дом 2, корпус 4, литера А.