

Features

- Pin- and function-compatible with CY7C107B/CY7C1007B
- High speed
 - $t_{AA} = 10 \text{ ns}$
- Low active power
 - $I_{CC} = 80 \text{ mA @ } 10 \text{ ns}$
- Low complementary metal oxide semiconductor (CMOS) standby power
 - $I_{SB2} = 3 \text{ mA}$
- 2.0 V data retention
- Automatic power-down when deselected
- CMOS for optimum speed/power
- Transistor transistor logic (TTL) compatible inputs and outputs
- CY7C107D available in Pb-free 28-pin 400-Mil wide Molded SOJ package. CY7C1007D available in Pb-free 28-pin 300-Mil wide Molded SOJ package

Functional Description ^[1]

The CY7C107D and CY7C1007D are high-performance CMOS static RAMs organized as 1,048,576 words by 1 bit. Easy memory expansion is provided by an active LOW Chip Enable (\overline{CE}) and tri-state drivers. These devices have an automatic power-down feature that reduces power consumption by more than 65% when deselected. The output pin (D_{OUT}) is placed in a high-impedance state when:

- Deselected (\overline{CE} HIGH)
- When the write operation is active (\overline{CE} and \overline{WE} LOW)

Write to the device by taking Chip Enable (\overline{CE}) and Write Enable (\overline{WE}) inputs LOW. Data on the input pin (D_{IN}) is written into the memory location specified on the address pins (A_0 through A_{19}).

Read from the device by taking Chip Enable (\overline{CE}) LOW while forcing Write Enable (\overline{WE}) HIGH. Under these conditions, the contents of the memory location specified by the address pins appears on the data output (D_{OUT}) pin.

Logic Block Diagram

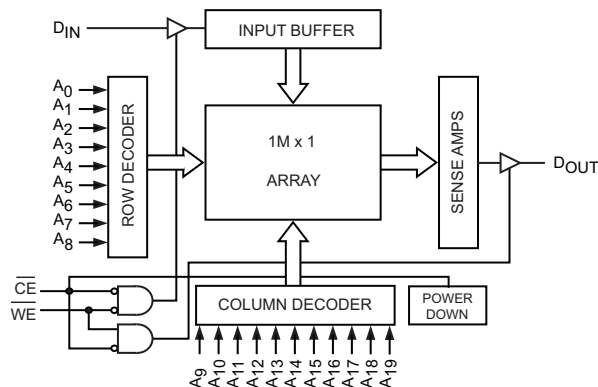

Note

1. For guidelines on SRAM system design, please refer to the 'System Design Guidelines' Cypress application note, available on the internet at www.cypress.com.

Contents

Pin Configuration	3	Truth Table	8
Selection Guide	3	Ordering Information	9
Maximum Ratings	4	Ordering Code Definitions	9
Operating Range	4	Package Diagrams	10
Electrical Characteristics	4	Acronyms	12
Capacitance	5	Document Conventions	12
Thermal Resistance	5	Units of Measure	12
AC Test Loads and Waveforms	5	Document History Page	13
Switching Characteristics	6	Sales, Solutions, and Legal Information	14
Data Retention Characteristics	7	Worldwide Sales and Design Support	14
Data Retention Waveform	7	Products	14
Switching Waveforms	7	PSoC Solutions	14

Pin Configuration [2]

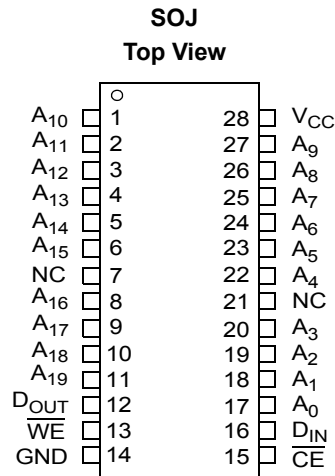

Selection Guide

	CY7C107D-10 CY7C1007D-10	Unit
Maximum access time	10	ns
Maximum operating current	80	mA
Maximum CMOS standby current, I _{SB2}	3	mA

Note
2. NC pins are not connected on the die.

Maximum Ratings

Exceeding the maximum ratings may impair the useful life of the device. These user guidelines are not tested.

Storage temperature -65 °C to +150 °C
 Ambient temperature with power applied..... -55 °C to +125 °C
 Supply voltage on V_{CC} relative to GND ^[3] ... -0.5 V to +6.0 V
 DC voltage applied to outputs in High-Z state ^[3] -0.5 V to V_{CC} + 0.5 V

DC input voltage ^[3] -0.5 V to V_{CC} + 0.5 V
 Current into outputs (LOW) 20 mA
 Static discharge voltage..... > 2001 V (per MIL-STD-883, Method 3015)
 Latch-up current > 200 mA

Operating Range

Range	Ambient Temperature	V _{CC}	Speed
Industrial	-40 °C to +85 °C	5 V ± 0.5 V	10 ns

Electrical Characteristics (Over the Operating Range)

Parameter	Description	Test Conditions	7C107D-10 7C1007D-10		Unit	
			Min	Max		
V _{OH}	Output HIGH voltage	I _{OH} = -4.0 mA	2.4	-	V	
V _{OL}	Output LOW voltage	I _{OL} = 8.0 mA	-	0.4	V	
V _{IH}	Input HIGH voltage		2.2	V _{CC} + 0.5	V	
V _{IL}	Input LOW voltage ^[3]		-0.5	0.8	V	
I _{Ix}	Input leakage current	GND ≤ V _I ≤ V _{CC}	-1	+1	μA	
I _{OZ}	Output leakage current	GND ≤ V _I ≤ V _{CC} , output disabled	-1	+1	μA	
I _{CC}	V _{CC} operating supply current	V _{CC} = Max, I _{OUT} = 0 mA, f = f _{max} = 1/t _{RC}	100 MHz	-	80	mA
			83 MHz	-	72	mA
			66 MHz	-	58	mA
			40 MHz	-	37	mA
I _{SB1}	Automatic \overline{CE} Power-down current— TTL Inputs	Max V _{CC} , $\overline{CE} \geq V_{IH}$, V _{IN} ≥ V _{IH} or V _{IN} ≤ V _{IL} , f = f _{max}	-	10	mA	
I _{SB2}	Automatic \overline{CE} Power-down current— CMOS Inputs	Max V _{CC} , $\overline{CE} \geq V_{CC} - 0.3V$, V _{IN} ≥ V _{CC} - 0.3V or V _{IN} ≤ 0.3V, f = 0	-	3	mA	

Note

3. V_{IL} (min) = -2.0 V and V_{IH}(max) = V_{CC} + 1 V for pulse durations of less than 5 ns.

Capacitance [4]

Parameter	Description	Test Conditions	Max	Unit
C _{IN} : Addresses	Input capacitance	T _A = 25 °C, f = 1 MHz, V _{CC} = 5.0 V	7	pF
C _{IN} : Controls			10	pF
C _{OUT}	Output capacitance		10	pF

Thermal Resistance [4]

Parameter	Description	Test Conditions	300-Mil Wide SOJ	400-Mil Wide SOJ	Unit
Θ _{JA}	Thermal resistance (junction to ambient)	Still Air, soldered on a 3 × 4.5 inch, four-layer printed circuit board	59.16	58.76	°C/W
Θ _{JC}	Thermal resistance (junction to case)		40.84	40.54	°C/W

AC Test Loads and Waveforms [5]

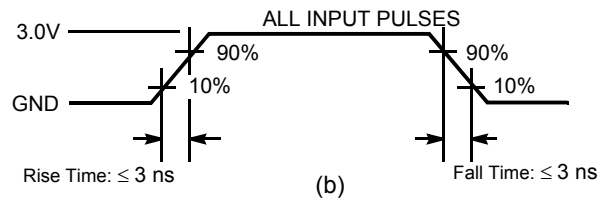
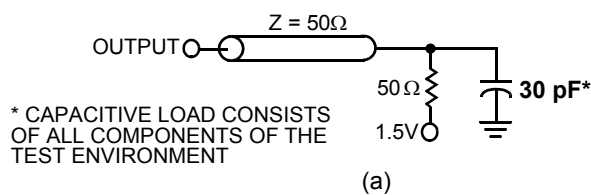

High-Z characteristics:

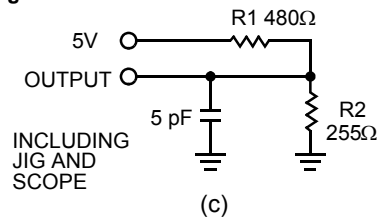

Notes

- Tested initially and after any design or process changes that may affect these parameters.
- AC characteristics (except High-Z) are tested using the load conditions shown in Figure (a). High-Z characteristics are tested for all speeds using the test load shown in Figure (c).

Switching Characteristics (Over the Operating Range) ^[6]

Parameter	Description	7C107D-10 7C1007D-10		Unit
		Min	Max	
Read Cycle				
$t_{power}^{[7]}$	V_{CC} (typical) to the first access	100	–	μ s
t_{RC}	Read cycle time	10	–	ns
t_{AA}	Address to data valid	–	10	ns
t_{OHA}	Data hold from address change	3		ns
t_{ACE}	\overline{CE} LOW to data valid	–	10	ns
t_{LZCE}	\overline{CE} LOW to Low Z ^[8]	3	–	ns
t_{HZCE}	\overline{CE} HIGH to High Z ^[8, 9]	–	5	ns
$t_{PU}^{[10]}$	\overline{CE} LOW to power-up	0	–	ns
$t_{PD}^{[10]}$	\overline{CE} HIGH to power-down	–	10	ns
Write Cycle ^[11]				
t_{WC}	Write cycle time	10	–	ns
t_{SCE}	\overline{CE} LOW to write end	7	–	ns
t_{AW}	Address set-up to write end	7	–	ns
t_{HA}	Address hold from write end	0	–	ns
t_{SA}	Address set-up to write start	0	–	ns
t_{PWE}	\overline{WE} pulse width	7	–	ns
t_{SD}	Data set-up to write end	6	–	ns
t_{HD}	Data hold from write end	0	–	ns
t_{LZWE}	\overline{WE} HIGH to Low Z ^[8]	3	–	ns
t_{HZWE}	\overline{WE} LOW to High Z ^[8, 9]	–	6	ns

Notes

6. Test conditions assume signal transition time of 3 ns or less, timing reference levels of 1.5V, input pulse levels of 0 to 3.0V, and output loading of the specified I_{OL}/I_{OH} and 30-pF load capacitance.
7. t_{POWER} gives the minimum amount of time that the power supply should be at typical V_{CC} values until the first memory access can be performed.
8. At any given temperature and voltage condition, t_{HZCE} is less than t_{LZCE} and t_{HZWE} is less than t_{LZWE} for any given device.
9. t_{HZCE} and t_{HZWE} are specified with a load capacitance of 5 pF as in part (c) of “AC Test Loads and Waveforms [5]” on page 5. Transition is measured when the outputs enter a high impedance state.
10. This parameter is guaranteed by design and is not tested.
11. The internal write time of the memory is defined by the overlap of \overline{CE} LOW and \overline{WE} LOW. \overline{CE} and \overline{WE} must be LOW to initiate a write, and the transition of any of these signals can terminate the write. The input data set-up and hold timing should be referenced to the leading edge of the signal that terminates the write.

Data Retention Characteristics (Over the Operating Range)

Parameter	Description	Conditions	Min	Max	Unit
V_{DR}	V_{CC} for data retention		2.0	–	V
I_{CCDR}	Data retention current	$V_{CC} = V_{DR} = 2.0\text{ V}$, $\overline{CE} \geq V_{CC} - 0.3\text{ V}$, $V_{IN} \geq V_{CC} - 0.3\text{ V}$ or $V_{IN} \leq 0.3\text{ V}$	–	3	mA
$t_{CDR}^{[12]}$	Chip deselect to data retention time		0	–	ns
$t_R^{[13]}$	Operation recovery time		t_{RC}	–	ns

Data Retention Waveform

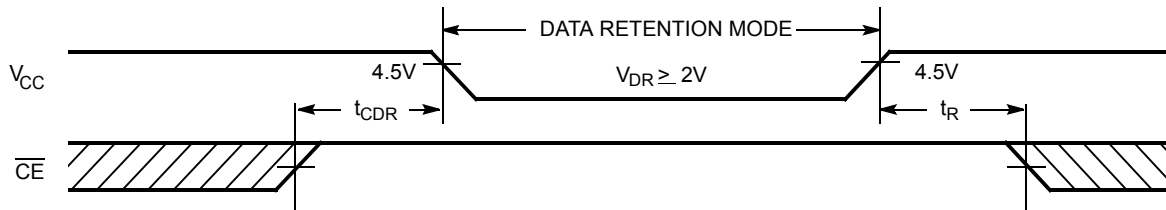

Switching Waveforms

Figure 1. Read Cycle No. 1 (Address Transition Controlled) [14, 15]

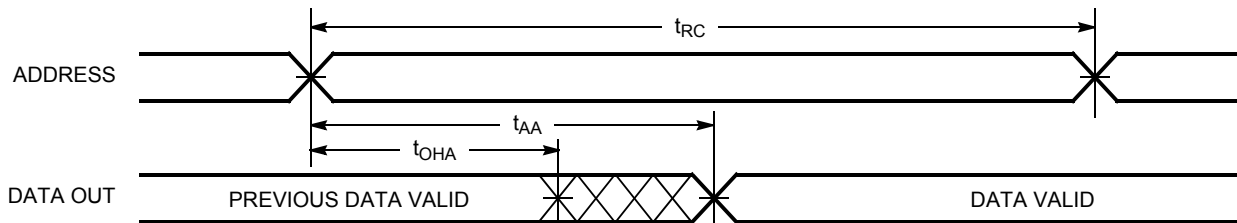
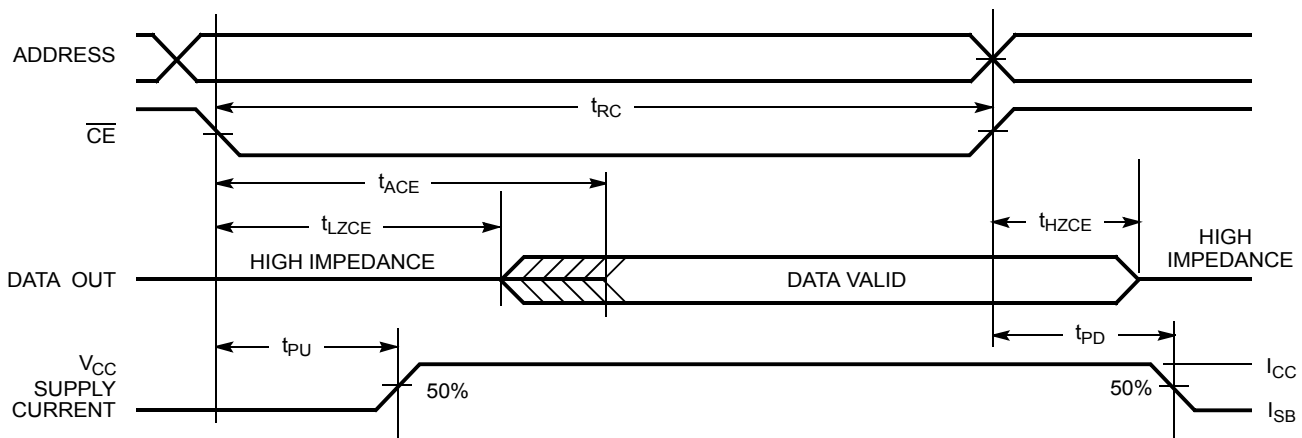

Figure 2. Read Cycle No. 2 [15, 16]



Notes

- 12. AC characteristics (except High-Z) are tested using the load conditions shown in Figure (a). High-Z characteristics are tested for all speeds using the test load shown in Figure (c)
- 13. Full device operation requires linear V_{CC} ramp from V_{DR} to $V_{CC(min)} \geq 50\ \mu\text{s}$ or stable at $V_{CC(min)} \geq 50\ \mu\text{s}$.
- 14. Device is continuously selected, $\overline{CE} = V_{IL}$.
- 15. \overline{WE} is HIGH for read cycle.
- 16. Address valid prior to or coincident with \overline{CE} transition LOW.

Switching Waveforms(continued)

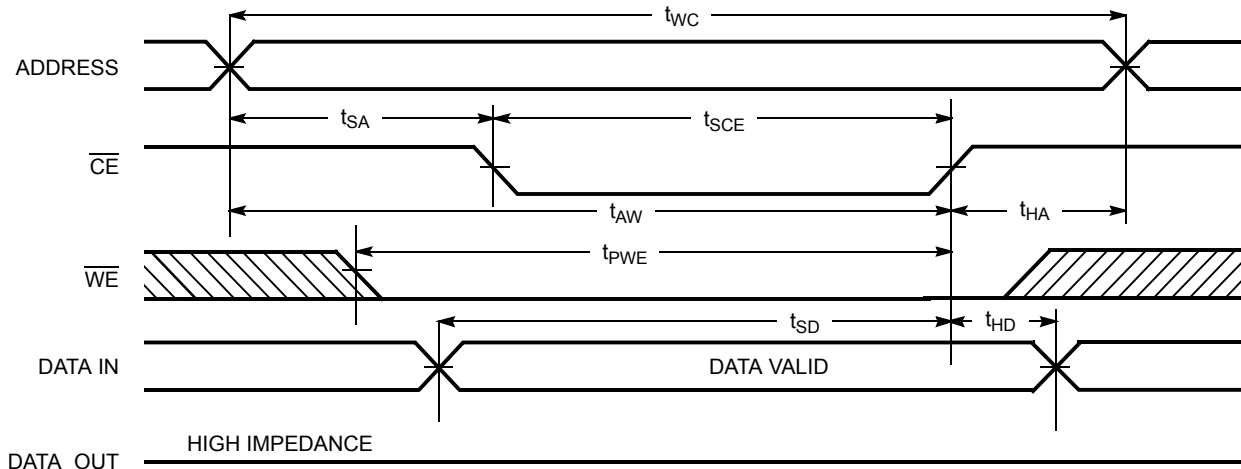
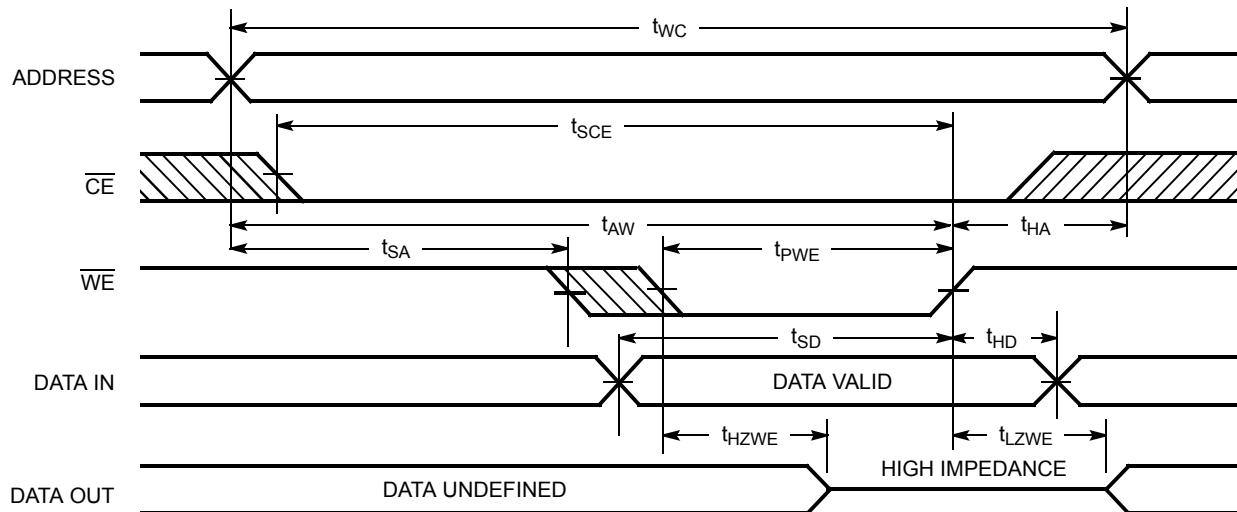
Figure 3. Write Cycle No. 1 (\overline{CE} Controlled) [17]

Figure 4. Write Cycle No. 2 (\overline{WE} Controlled) [17]

Truth Table

\overline{CE}	\overline{WE}	D_{OUT}	Mode	Power
H	X	High Z	Power-down	Standby (I_{SB})
L	H	Data out	Read	Active (I_{CC})
L	L	High Z	Write	Active (I_{CC})

Note
 17. If \overline{CE} goes HIGH simultaneously with \overline{WE} going HIGH, the output remains in a high-impedance state.

Ordering Information

Speed (ns)	Ordering Code	Package Diagram	Package Type	Operating Range
10	CY7C107D-10VXI	51-85032	28-pin (400-Mil) Molded SOJ (Pb-free)	Industrial
	CY7C1007D-10VXI	51-85031	28-pin (300-Mil) Molded SOJ (Pb-free)	

Ordering Code Definitions

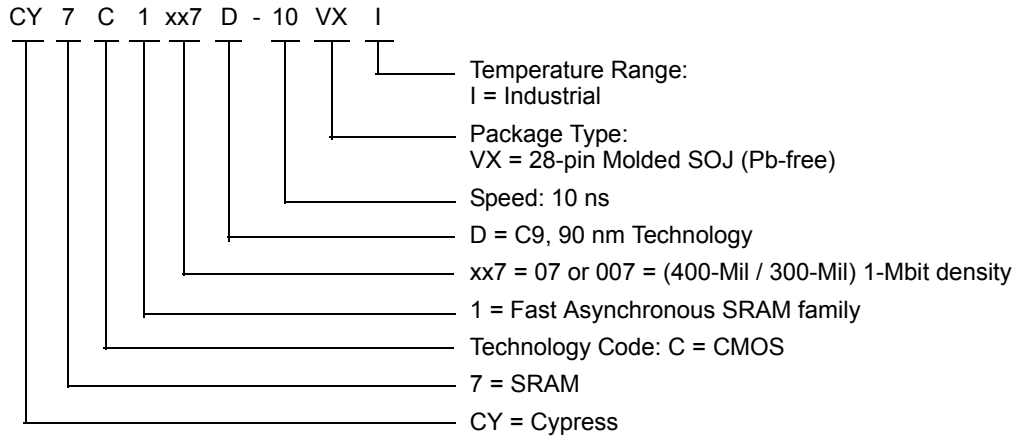

Please contact your local Cypress sales representative for availability of these parts.

Package Diagrams

Figure 5. 28-pin (400-Mil) Molded SOJ, 51-85032

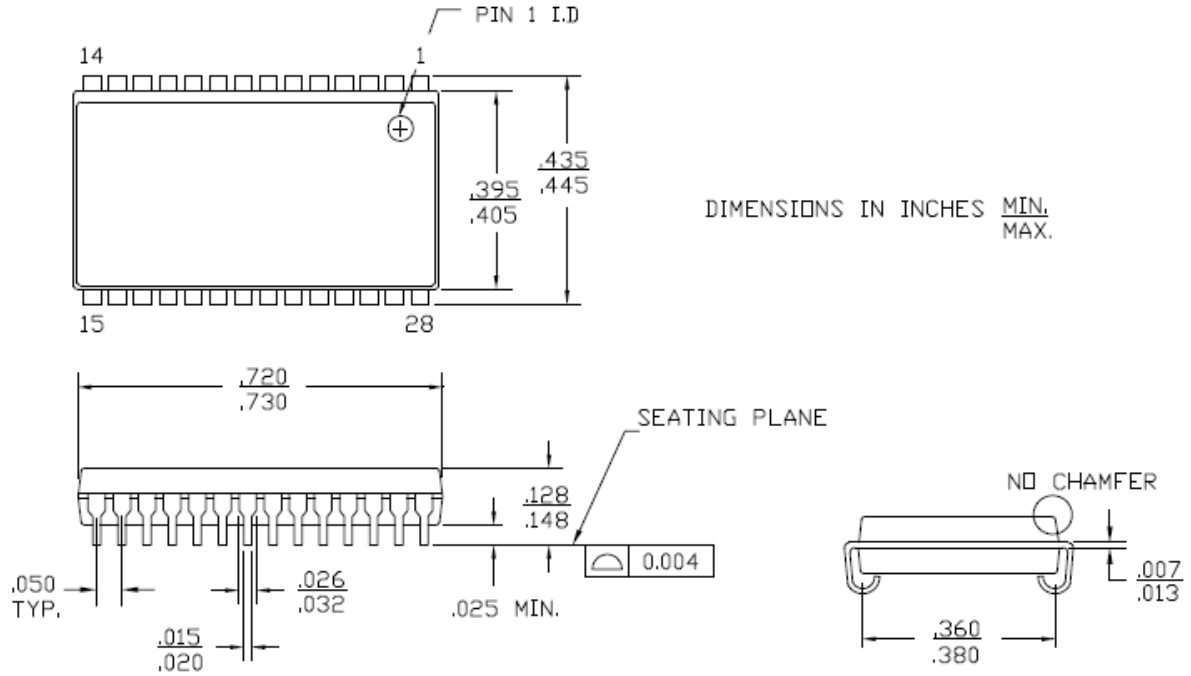

- NOTES :
1. PACKAGE WEIGHT : 1.24g
 2. JEDEC REFERENCE : MS-027

51-85032 *E

Package Diagrams(continued)

Figure 6. 28-pin (300-Mil) Molded SOJ, 51-85031

NOTE :

1. JEDEC STD REF MO088
2. BODY LENGTH DIMENSION DOES NOT INCLUDE MOLD PROTRUSION/END FLASH
MOLD PROTRUSION/END FLASH SHALL NOT EXCEED 0.006 in (0.152 mm) PER SIDE
3. DIMENSIONS IN INCHES MIN.
MAX.

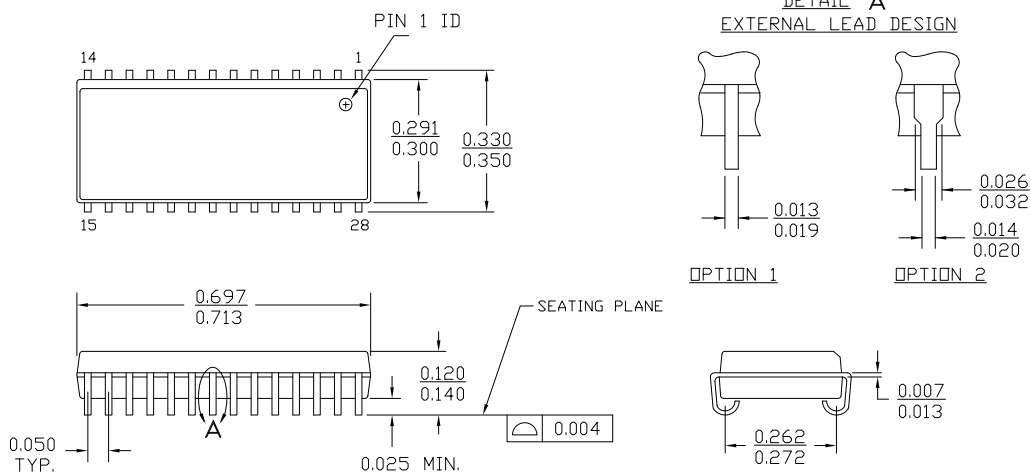

51-85031 *D

All product and company names mentioned in this document may be the trademarks of their respective holders.

Acronyms

Acronym	Description
BGA	ball grid array
CMOS	complementary metal oxide semiconductor
FBGA	very fine ball grid array
I/O	input/output
JTAG	joint test action group
SRAM	static random access memory
TTL	Transistor transistor logic

Document Conventions

Units of Measure

Symbol	Unit of Measure
°C	degrees Celsius
μA	microamperes
mA	milliampere
MHz	megahertz
ns	nanoseconds
pF	picofarads
V	volts
Ω	ohms
W	watts

Document History Page

Document Title: CY7C107D/CY7C1007D, 1-Mbit (1M x 1) Static RAM				
Document Number: 38-05469				
REV.	ECN NO.	Issue Date	Orig. of Change	Description of Change
**	201560	See ECN	SWI	Advance Information data sheet for C9 IPP
*A	233722	See ECN	RKF	DC parameters modified as per EROS (Spec # 01-02165) Pb-free offering in Ordering Information
*B	263769	See ECN	RKF	Added Data Retention Characteristics table Added T _{power} Spec in Switching Characteristics Table Shaded Ordering Information
*C	307601	See ECN	RKF	Reduced Speed bins to -10 and -12 ns
*D	560995	See ECN	VKN	Converted from Preliminary to Final Removed Commercial Operating range Removed 12 ns speed bin Added I _{CC} values for the frequencies 83MHz, 66MHz and 40MHz Updated Thermal Resistance table Updated Ordering Information Table Changed Overshoot spec from V _{CC} +2V to V _{CC} +1V in footnote #3
*E	802877	See ECN	VKN	Changed I _{CC} specs from 60 mA to 80 mA for 100MHz, 55 mA to 72 mA for 83MHz, 45 mA to 58 mA for 66MHz, 30 mA to 37 mA for 40MHz
*F	2898399	03/24/2010	AJU	Updated Package Diagrams
*G	3104943	12/08/2010	AJU	Added Ordering Code Definitions .
*H	3218989	04/07/2011	PRAS	Added TOC Added Acnyms and Units of Measure table. Updated Package diagrams from *C to *D (51-85032)

Sales, Solutions, and Legal Information

Worldwide Sales and Design Support

Cypress maintains a worldwide network of offices, solution centers, manufacturer's representatives, and distributors. To find the office closest to you, visit us at [Cypress Locations](#).

Products

Automotive	cypress.com/go/automotive
Clocks & Buffers	cypress.com/go/clocks
Interface	cypress.com/go/interface
Lighting & Power Control	cypress.com/go/powerpsoc cypress.com/go/plc
Memory	cypress.com/go/memory
Optical & Image Sensing	cypress.com/go/image
PSoC	cypress.com/go/psoc
Touch Sensing	cypress.com/go/touch
USB Controllers	cypress.com/go/USB
Wireless/RF	cypress.com/go/wireless

PSoC Solutions

psoc.cypress.com/solutions
PSoC 1 | PSoC 3 | PSoC 5

© Cypress Semiconductor Corporation, 2007-2011. The information contained herein is subject to change without notice. Cypress Semiconductor Corporation assumes no responsibility for the use of any circuitry other than circuitry embodied in a Cypress product. Nor does it convey or imply any license under patent or other rights. Cypress products are not warranted nor intended to be used for medical, life support, life saving, critical control or safety applications, unless pursuant to an express written agreement with Cypress. Furthermore, Cypress does not authorize its products for use as critical components in life-support systems where a malfunction or failure may reasonably be expected to result in significant injury to the user. The inclusion of Cypress products in life-support systems application implies that the manufacturer assumes all risk of such use and in doing so indemnifies Cypress against all charges.

Any Source Code (software and/or firmware) is owned by Cypress Semiconductor Corporation (Cypress) and is protected by and subject to worldwide patent protection (United States and foreign), United States copyright laws and international treaty provisions. Cypress hereby grants to licensee a personal, non-exclusive, non-transferable license to copy, use, modify, create derivative works of, and compile the Cypress Source Code and derivative works for the sole purpose of creating custom software and or firmware in support of licensee product to be used only in conjunction with a Cypress integrated circuit as specified in the applicable agreement. Any reproduction, modification, translation, compilation, or representation of this Source Code except as specified above is prohibited without the express written permission of Cypress.

Disclaimer: CYPRESS MAKES NO WARRANTY OF ANY KIND, EXPRESS OR IMPLIED, WITH REGARD TO THIS MATERIAL, INCLUDING, BUT NOT LIMITED TO, THE IMPLIED WARRANTIES OF MERCHANTABILITY AND FITNESS FOR A PARTICULAR PURPOSE. Cypress reserves the right to make changes without further notice to the materials described herein. Cypress does not assume any liability arising out of the application or use of any product or circuit described herein. Cypress does not authorize its products for use as critical components in life-support systems where a malfunction or failure may reasonably be expected to result in significant injury to the user. The inclusion of Cypress' product in a life-support systems application implies that the manufacturer assumes all risk of such use and in doing so indemnifies Cypress against all charges.

Use may be limited by and subject to the applicable Cypress software license agreement.



Компания «ЭлектроПласт» предлагает заключение долгосрочных отношений при поставках импортных электронных компонентов на взаимовыгодных условиях!

Наши преимущества:

- Оперативные поставки широкого спектра электронных компонентов отечественного и импортного производства напрямую от производителей и с крупнейших мировых складов;
- Поставка более 17-ти миллионов наименований электронных компонентов;
- Поставка сложных, дефицитных, либо снятых с производства позиций;
- Оперативные сроки поставки под заказ (от 5 рабочих дней);
- Экспресс доставка в любую точку России;
- Техническая поддержка проекта, помощь в подборе аналогов, поставка прототипов;
- Система менеджмента качества сертифицирована по Международному стандарту ISO 9001;
- Лицензия ФСБ на осуществление работ с использованием сведений, составляющих государственную тайну;
- Поставка специализированных компонентов (Xilinx, Altera, Analog Devices, Intersil, Interpoint, Microsemi, Aeroflex, Peregrine, Syfer, Eurofarad, Texas Instrument, Miteq, Cobham, E2V, MA-COM, Hittite, Mini-Circuits, General Dynamics и др.);

Помимо этого, одним из направлений компании «ЭлектроПласт» является направление «Источники питания». Мы предлагаем Вам помощь Конструкторского отдела:

- Подбор оптимального решения, техническое обоснование при выборе компонента;
- Подбор аналогов;
- Консультации по применению компонента;
- Поставка образцов и прототипов;
- Техническая поддержка проекта;
- Защита от снятия компонента с производства.



Как с нами связаться

Телефон: 8 (812) 309 58 32 (многоканальный)

Факс: 8 (812) 320-02-42

Электронная почта: org@eplast1.ru

Адрес: 198099, г. Санкт-Петербург, ул. Калинина, дом 2, корпус 4, литера А.