

REVISIONS				
REV.	ECN/E-R	DESCRIPTION	DATE	APPROVED
B		CUSTOMER DRAWING	2006/04/05	J.SI
C		UPDATED	2006/08/09	
D		UPDATED	2007/01/02	



AMPHENOL PART NUMBER CONFIGURATION:

UE78 - A 1 1 1 8 - 0 X X X X

OPTIONAL DUST COVER
 0 - WITHOUT DUST COVER
 D - WITH DUST COVER (SHIP LOOSE)

PLATING OPTIONS FOR CONNECTOR
 2 - 30µ" GOLD PLATING ON MATING AREA
 GOLD FLASH ON TERMINATION
 3 - 30µ" GOLD PLATING ON MATING AREA
 150-300µ" MATTE TIN ON TERMINATION
 5 - 15µ" GOLD PLATING ON MATING AREA
 GOLD FLASH ON TERMINATION
 6 - 15µ" GOLD PLATING ON MATING AREA
 150-300µ" MATTE TIN ON TERMINATION

PACKAGING OPTIONS
 T - TAPE AND REEL PACKAGING
 FOR BOTH CONNECTORS AND
 CAGES
 H - TAPE AND REEL FOR
 CONNECTORS TRAY FOR
 CAGES

PLATING OPTIONS FOR CAGE
 1 - TIN
 2 - NICKEL

MATERIAL (RoHS COMPLIANCE):

CAGE:
 COPPER ALLOY
 PLATING OPTION 1: 100µ" [2.54 µm] TIN PLATING OVER
 50 µ" (1.27 µm) NICKEL UNDER PLATING.
 PLATING OPTION 2: 100µ" [2.54 µm] NICKEL PLATING
 (NOT FOR SOLDER PINS).
DUST COVER
 THERMOPLASTIC, COLOR BLACK.
PACKAGING:
 TAPE AND REEL OR TRAY PACKAGING.
 TEMPERATURE RANGE: -40 °C TO +85 °C

CONNECTOR:

PLASTIC HOUSING:
 HIGH TEMPERATURE RESISTANT NYLON FLAMMABILITY RATING UL94V-0.
CONTACTS:
 PHOSPHOR BRONZE
 PLATING OPTION 2: 30µ" [0.76 µm] GOLD ON MATING AREA AND 2 µ"
 (0.05 µm) GOLD FLASH PLATING ON TERMINATION OVER
 50µ"[1.27µm] NICKEL UNDER LAYER.
 PLATING OPTION 3: 30µ" [0.76 µm] GOLD ON MATING AREA AND
 150-300 µ" (3.81-7.62 µm) LOW WHISKER MATTE TIN PLATING
 ON TERMINATION OVER 50µ" [1.27 µm] NICKEL UNDER LAYER.
 PLATING OPTION 5: 15µ" GOLD PLATING ON MATING AREA
 GOLD FLASH ON TERMINATION
 PLATING OPTION 6: 15µ" GOLD PLATING ON MATING AREA
 150-300µ" (3.81-7.62 µm) MATTE TIN ON TERMINATION

PACKAGING:
 TAPE AND REEL.
 TEMPERATURE RANGE: -40 °C TO +85 °C

DO NOT SCALE DRAWING

THIS DOCUMENT CONTAINS PROPRIETARY INFORMATION AND SUCH INFORMATION MAY NOT BE DISCLOSED TO OTHERS FOR ANY PURPOSE OR USED FOR MANUFACTURING PUPOSES WITHOUT PERMISSION FROM AMPHENOL CANADA CORP.

APPROVALS		DATE	Amphenol Canada Corp.		
DRAWN	A.LIU	2006/02/13	TITLE SFP CAGE + CONNECTOR 1X1 8 PRESS FIT / 12 EMI PINS		
DESIGNED	J.SI	2006/02/13			
CHECKED	J.SI	2006/02/13			
QA APPD	X	X			
IE APPD	X	X	SIZE A3	DWG. NO. P-UE78-A1118-0XXXX	REV. D
DWG APPD			SCALE 2:1	PROJECT	SHEET 1 OF 7



REVISIONS				
REV.	ECN/E-R	DESCRIPTION	DATE	APPROVED
B		CUSTOMER DRAWING	2006/04/05	J.SI
C		UPDATED	2006/08/09	
D		UPDATED	2007/01/02	

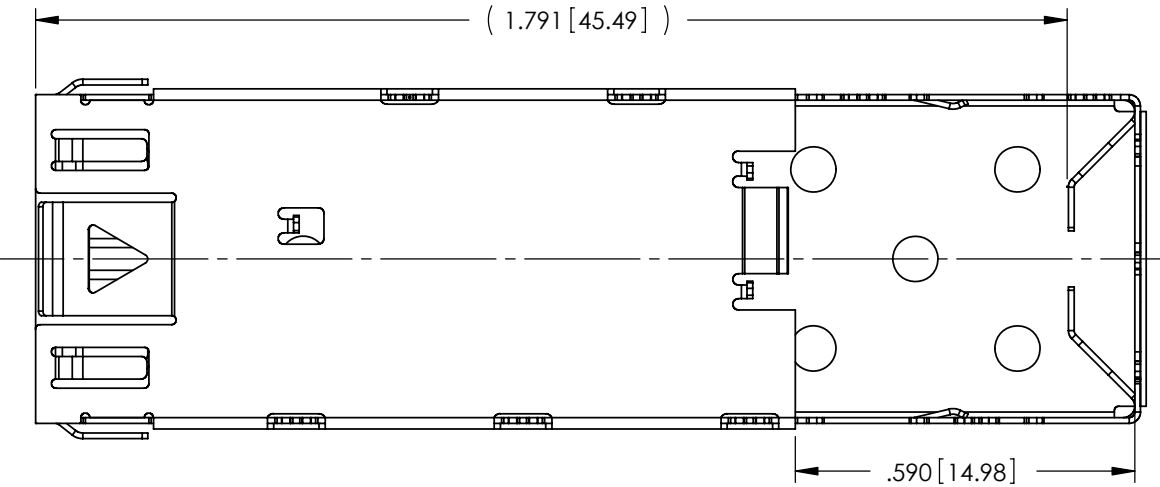

APPROVALS		DATE	Amphenol Canada Corp.		
DRAWN	A.LIU	2006/02/13	TITLE		
DESIGNED	J.SI	2006/02/13	SFP CAGE + CONNECTOR 1X1 8 PRESS FIT / 12 EMI PINS		
CHECKED	J.SI	2006/02/13	REV. D		
QA APPD	X	X	SIZE	DWG. NO.	REV.
IE APPD	X	X	A3	P-UE78-A1118-OXXXX	D
DWG APPD			SCALE	PROJECT	SHEET
			2:1		2 OF 7

DO NOT SCALE DRAWING

THIS DOCUMENT CONTAINS PROPRIETARY INFORMATION AND SUCH INFORMATION MAY NOT BE DISCLOSED TO OTHERS FOR ANY PURPOSE OR USED FOR MANUFACTURING PUPOSES WITHOUT PERMISSION FROM AMPHENOL CANADA CORP.

REVISIONS				
REV.	ECN/E-R	DESCRIPTION	DATE	APPROVED
B		CUSTOMER DRAWING	2006/04/05	J.SI
C		UPDATED	2006/08/09	
D		UPDATED	2007/01/02	

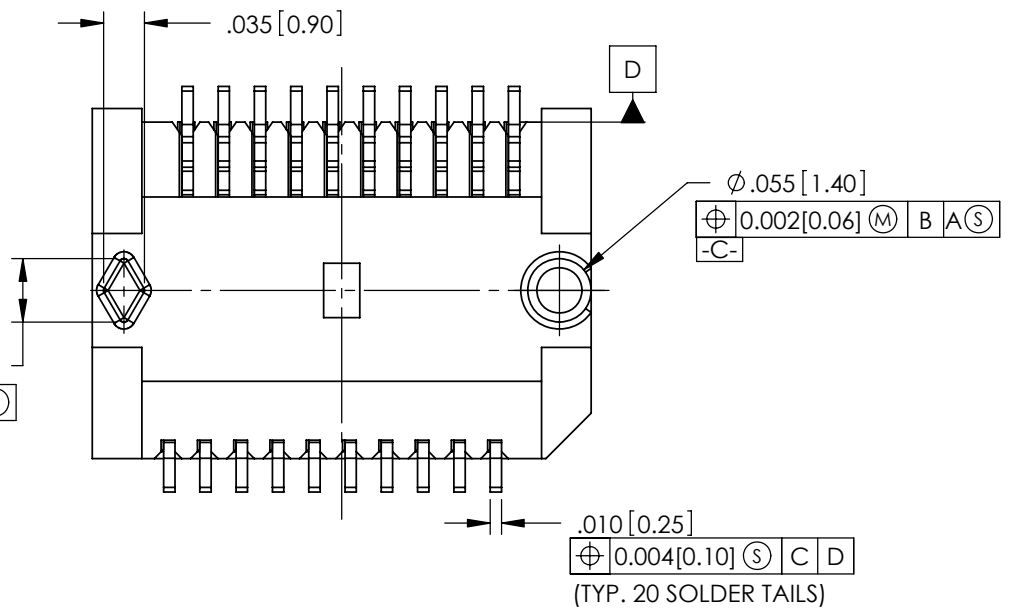

$\phi 0.002 [0.06] (M) B A (S) C (S)$

$\phi 0.004 [0.10] (S) C D$
(TYP. 20 SOLDER TAILS)

DO NOT SCALE DRAWING

THIS DOCUMENT CONTAINS PROPRIETARY INFORMATION AND SUCH INFORMATION MAY NOT BE DISCLOSED TO OTHERS FOR ANY PURPOSE OR USED FOR MANUFACTURING PURPOSES WITHOUT PERMISSION FROM AMPHENOL CANADA CORP.

APPROVALS		DATE	Amphenol Canada Corp.		
DRAWN	A.LIU	2006/02/13	TITLE		
DESIGNED	J.SI	2006/02/13	SFP CAGE + CONNECTOR 1X1 8 PRESS FIT / 12 EMI PINS		
CHECKED	J.SI	2006/02/13			
QA APPD	X	X			
IE APPD	X	X	SIZE A3	DWG. NO. P-UE78-A1118-0XXXX	REV. D
DWG APPD			SCALE 4:1	PROJECT	SHEET 3 OF 7

REVISIONS				
REV.	ECN/E-R	DESCRIPTION	DATE	APPROVED
B		CUSTOMER DRAWING	2006/04/05	
C		UPDATED	2006/08/09	
D		UPDATED	2007/01/02	



TOP VIEW OF BOAD



BOTTOM VIEW OF BOAD

RECOMMENDED LAYOUT DETAIL
MATING TRANSCEIVER PCB

DO NOT SCALE DRAWING

THIS DOCUMENT CONTAINS PROPRIETARY INFORMATION AND SUCH INFORMATION MAY NOT BE DISCLOSED TO OTHERS FOR ANY PURPOSE OR USED FOR MANUFACTURING PUPOSES WITHOUT PERMISSION FROM AMPHENOL CANADA CORP.

APPROVALS		DATE	Amphenol Canada Corp.		
DRAWN	A.LIU	2006/02/13	TITLE SFP CAGE + CONNECTOR 1X1 8 PRESS FIT / 12 EMI PINS		
DESIGNED	J.SI	2006/02/13			
CHECKED	J.SI	2006/02/13			
QA APPD	X	X			
IE APPD	X	X	SIZE A3	DWG. NO. P-UE78-A1118-0XXXX	REV. D
DWG APPD			SCALE 4:1	PROJECT	SHEET 4 OF 7

REVISIONS

REV.	ECN/E-R	DESCRIPTION	DATE	APPROVED
B		CUSTOMER DRAWING	2006/04/05	J.SI
C		UPDATED	2006/08/09	
D		UPDATED	2007/01/02	

NOTES;
 1. DATUM AND BASIC DIMENTIONS ESTABLISHED BY CUSTOMER
 2. PADS AND VIAS ARE CHASSIS GROUND, 11 PLACES.
 3. THROUGH HOLES, PLATING OPTIONAL.



BSC
(SEE NOTE 1)

$\phi .004 [0.10] \text{ (L) X F (S)}$
 $\phi .004 [0.10] \text{ (L) X F (S)}$
 (10 HOLES. SEE NOTE 2)

$\phi .033 \pm .002 [0.85 \pm 0.05]$
 $\phi .004 [0.10] \text{ (S) X Y}$
 -F-

COMPONENT AND TRACES KEEP-OUT (EXCEPT CHASSIS GROUND) (SEE NOTE 4)

THIS AREA DENOTES COMPONENT KEEP-OUT (TRACES ALLOWED)
 CONNECTOR STANDOFFS AREA. COMPONENT AND TRACES KEEP-OUT (4 PLCS)

RECOMMENDED SFP HOST BOARD LAYOUT (ONE SIDE CAGE MOUNTING)

DETAIL H
SCALE 4 : 1

DO NOT SCALE DRAWING

THIS DOCUMENT CONTAINS PROPRIETARY INFORMATION AND SUCH INFORMATION MAY NOT BE DISCLOSED TO OTHERS FOR ANY PURPOSE OR USED FOR MANUFACTURING PUPOSES WITHOUT PERMISSION FROM AMPHENOL CANADA CORP.

APPROVALS		DATE	Amphenol Canada Corp.	
DRAWN	A.LIU	2006/02/13	TITLE	
DESIGNED	J.SI	2006/02/13	SFP CAGE + CONNECTOR 1X1 8 PRESS FIT / 12 EMI PINS	
CHECKED	J.SI	2006/02/13	SIZE	DWG. NO.
QA APPD	X	X	A3	P-UE78-A1118-0XXXX
IE APPD	X	X	SCALE	REV. D
DWG APPD			2:1	PROJECT SHEET 5 OF 7

REVISIONS				
REV.	ECN/E-R	DESCRIPTION	DATE	APPROVED
B		CUSTOMER DRAWING	2006/04/05	J.SI
C		UPDATED	2006/08/09	
D		UPDATED	2007/01/02	



RECOMMENDED BEZEL DESIGN
(ONE SIDE CAGE MOUNTING)

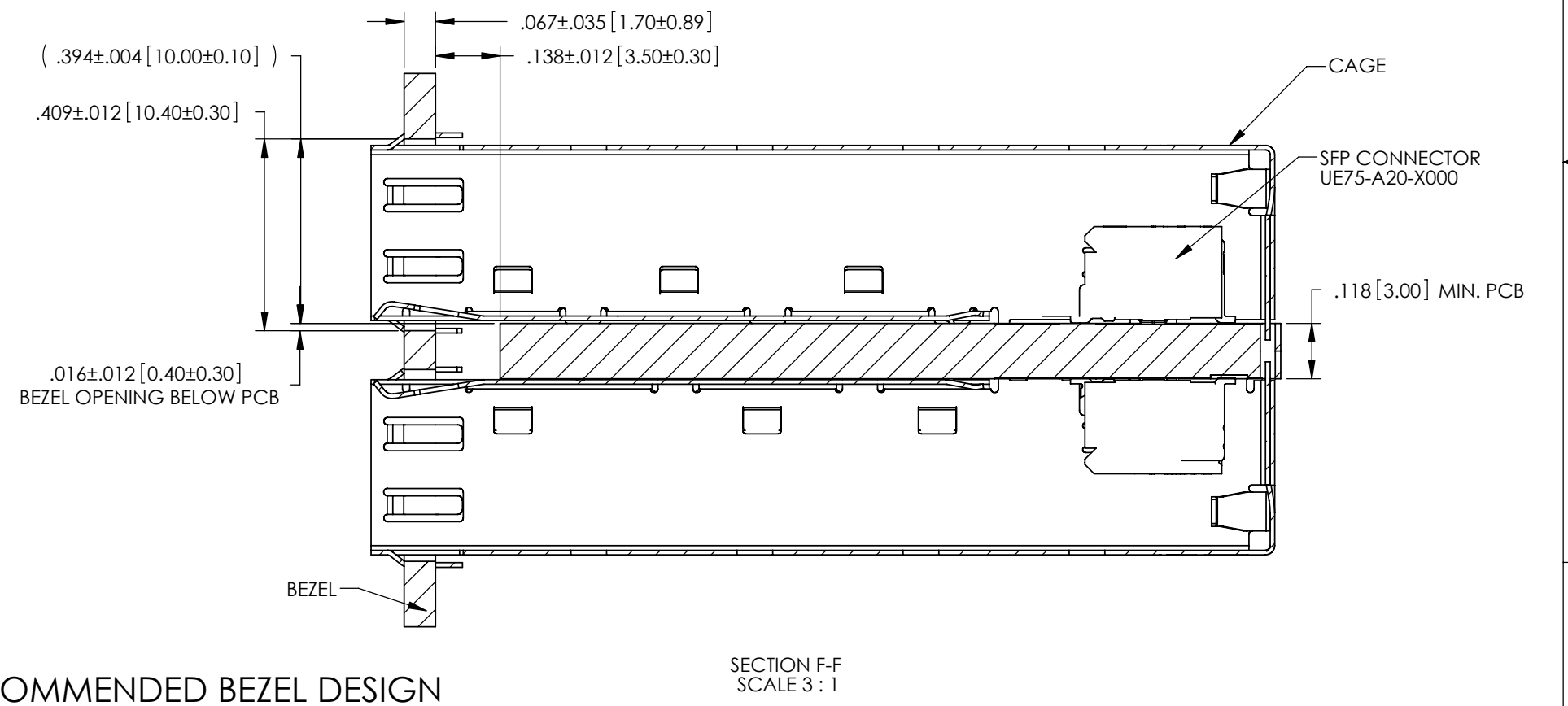

RECOMMENDED BEZEL DESIGN
(BELLY TO BELLY CAGE MOUNTING)

DO NOT SCALE DRAWING

THIS DOCUMENT CONTAINS PROPRIETARY INFORMATION AND SUCH INFORMATION MAY NOT BE DISCLOSED TO OTHERS FOR ANY PURPOSE OR USED FOR MANUFACTURING PUPOSES WITHOUT PERMISSION FROM AMPHENOL CANADA CORP.

APPROVALS		DATE	Amphenol Canada Corp.	
DRAWN	A.LIU	2006/02/13	TITLE	
DESIGNED	J.SI	2006/02/13	SFP CAGE + CONNECTOR 1X1 8 PRESS FIT / 12 EMI PINS	
CHECKED	J.SI	2006/02/13	SIZE A3	DWG. NO. P-UE78-A1118-0XXXX
QA APPD	X	X	SCALE 2:1	PROJECT
IE APPD	X	X	SHEET 6 OF 7	REV. D
DWG APPD				

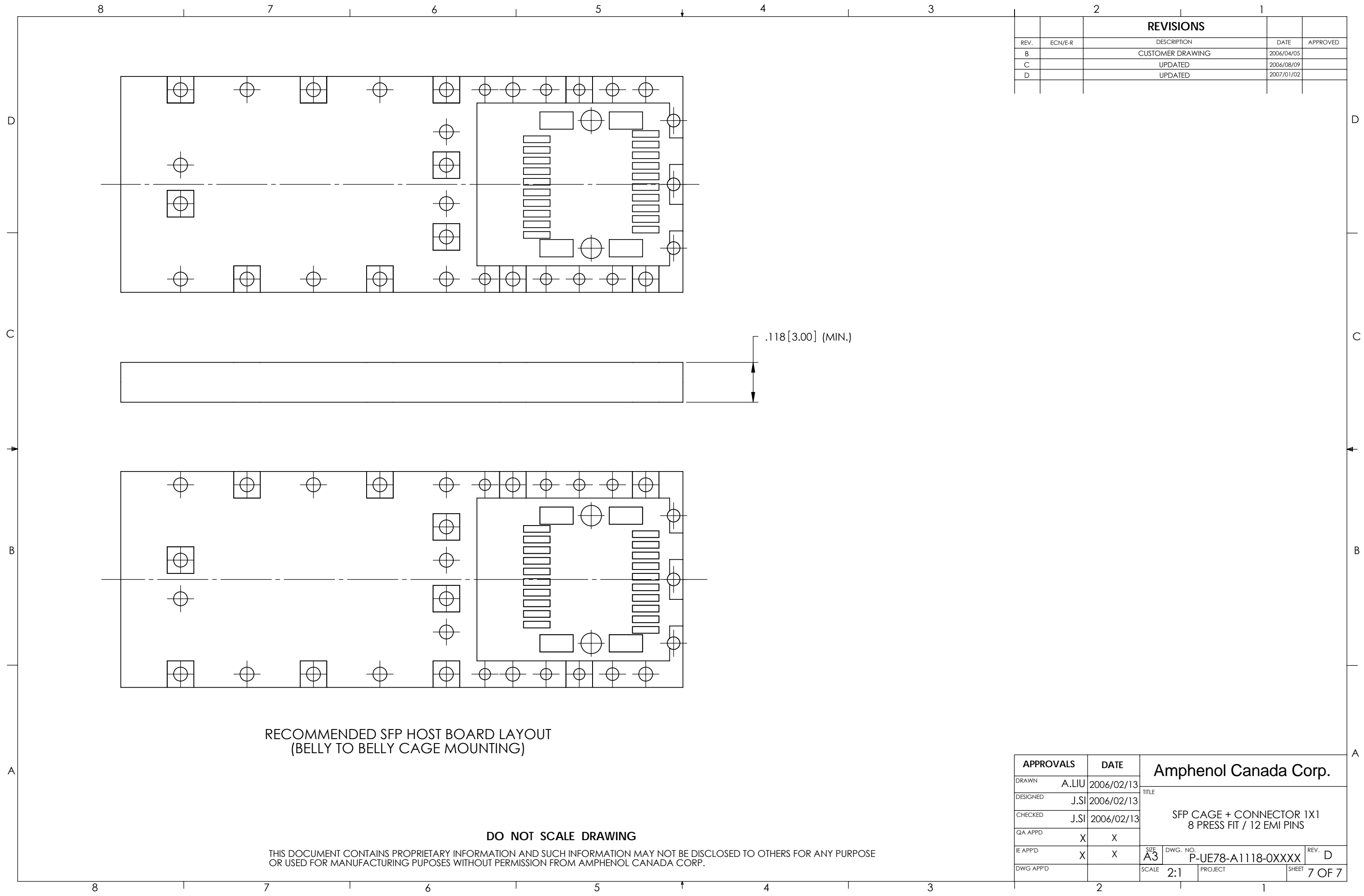

REVISIONS				
REV.	ECN/E-R	DESCRIPTION	DATE	APPROVED
B		CUSTOMER DRAWING	2006/04/05	
C		UPDATED	2006/08/09	
D		UPDATED	2007/01/02	

RECOMMENDED SFP HOST BOARD LAYOUT
(BELLY TO BELLY CAGE MOUNTING)

DO NOT SCALE DRAWING

THIS DOCUMENT CONTAINS PROPRIETARY INFORMATION AND SUCH INFORMATION MAY NOT BE DISCLOSED TO OTHERS FOR ANY PURPOSE OR USED FOR MANUFACTURING PUPOSES WITHOUT PERMISSION FROM AMPHENOL CANADA CORP.

APPROVALS		DATE	Amphenol Canada Corp.					
DRAWN	A.LIU	2006/02/13						
DESIGNED	J.SI	2006/02/13	TITLE SFP CAGE + CONNECTOR 1X1 8 PRESS FIT / 12 EMI PINS					
CHECKED	J.SI	2006/02/13						
QA APPD	X	X	SIZE A3					
IE APPD	X	X						
DWG APPD			SCALE	2:1	PROJECT	1	SHEET	7 OF 7



Компания «ЭлектроПласт» предлагает заключение долгосрочных отношений при поставках импортных электронных компонентов на взаимовыгодных условиях!

Наши преимущества:

- Оперативные поставки широкого спектра электронных компонентов отечественного и импортного производства напрямую от производителей и с крупнейших мировых складов;
- Поставка более 17-ти миллионов наименований электронных компонентов;
- Поставка сложных, дефицитных, либо снятых с производства позиций;
- Оперативные сроки поставки под заказ (от 5 рабочих дней);
- Экспресс доставка в любую точку России;
- Техническая поддержка проекта, помощь в подборе аналогов, поставка прототипов;
- Система менеджмента качества сертифицирована по Международному стандарту ISO 9001;
- Лицензия ФСБ на осуществление работ с использованием сведений, составляющих государственную тайну;
- Поставка специализированных компонентов (Xilinx, Altera, Analog Devices, Intersil, Interpoint, Microsemi, Aeroflex, Peregrine, Syfer, Eurofarad, Texas Instrument, Miteq, Cobham, E2V, MA-COM, Hittite, Mini-Circuits, General Dynamics и др.);

Помимо этого, одним из направлений компании «ЭлектроПласт» является направление «Источники питания». Мы предлагаем Вам помощь Конструкторского отдела:

- Подбор оптимального решения, техническое обоснование при выборе компонента;
- Подбор аналогов;
- Консультации по применению компонента;
- Поставка образцов и прототипов;
- Техническая поддержка проекта;
- Защита от снятия компонента с производства.



Как с нами связаться

Телефон: 8 (812) 309 58 32 (многоканальный)

Факс: 8 (812) 320-02-42

Электронная почта: org@eplast1.ru

Адрес: 198099, г. Санкт-Петербург, ул. Калинина, дом 2, корпус 4, литера А.