

MAX16913/MAX16913A

Remote Antenna Current-Sense Amplifier and Switches

General Description

The MAX16913/MAX16913A high-voltage high-side current-sense switches feature internal current limiting to prevent system damage due to fault conditions. The MAX16913/MAX16913A input voltage range extends from 5V to 18V, making them ideal for providing phantom power to remote radio-frequency low-noise amplifiers (LNAs) in automotive applications.

The MAX16913/MAX16913A monitor the load current and provide an analog output voltage proportional to the sensed load current. In addition to current sensing, accurate internal current-limiting circuitry protects the input supply against both overload and short-circuit conditions. Two open-drain fault indicator outputs notify the microprocessor when a short circuit, an open-load condition, or a short-to-battery condition exists. For the MAX16913A, the open-load threshold is externally adjustable using a resistive divider.

A fault-blanking feature enables the circuit to ignore momentary faults, such as those caused by the initial charging of a capacitive load when hot swapping, preventing false alarms to the system. Built-in thermal-overload protection turns off the switch when the die temperature exceeds +150°C (min). The MAX16913/MAX16913A also feature a short-to-battery detection every time the internal switch turns on. These devices provide an active-high control input to put the devices in low-power shutdown mode.

The MAX16913/MAX16913A are available in the 16-pin QSOP package and operate over the -40°C to +105°C temperature range.

Applications

- Remote LNA Phantom Power
- Automotive Safety and Infotainment

Pin Configuration, Functional Diagrams, and Ordering Information appear at end of data sheet.

Features

- Switch Phantom Power-On/-Off Under μ C Control
- Analog Current Measurement Output
- Adjustable Current Limiting (340mA Maximum)
- Detect Open-Load and Short-Circuit Conditions
- Provide Open-Drain Fault Signals (\overline{SC} and \overline{OL})
- Overcurrent Blanking During Startup
- Thermal Shutdown
- AECQ100 Qualified (I/V Versions Only)
- -40°C to +105°C Operating Temperature Range

Typical Application Circuits

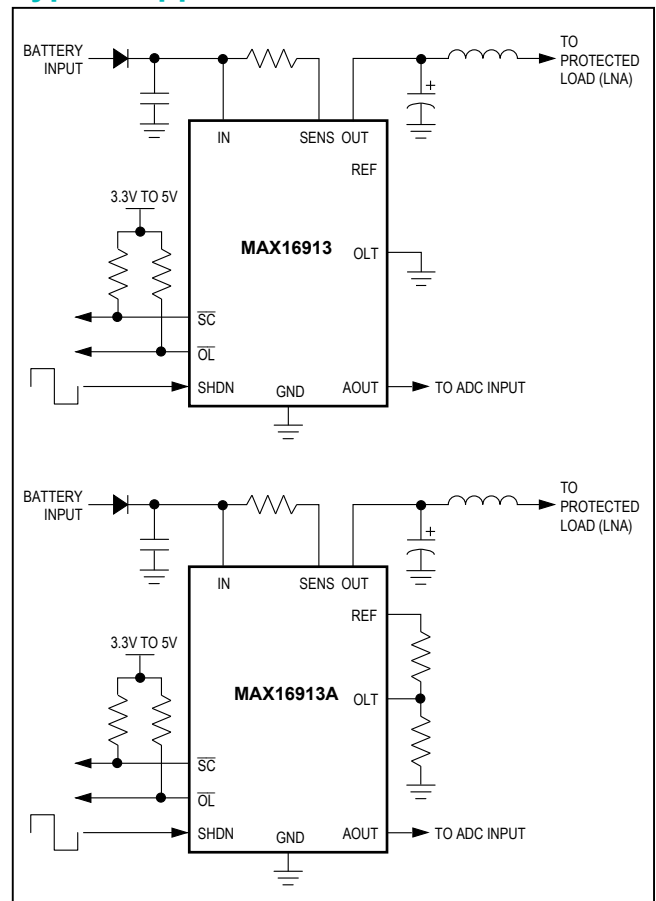

Absolute Maximum Ratings

IN to GND.....	-0.3V to +42V	Continuous Power Dissipation (T _A = +70°C)
OUT to GND.....	-0.3V to +42V	16-Pin QSOP (derate 18.2mW/°C above +70°C) ..1454.5mW
SENS to IN.....	-0.3V to +0.3V	Operating Temperature Range.....
SC, OL, SHDN, OLT, AOUT to GND.....	-0.3V to +6.0V	-40°C to +105°C
Current into Any Pin Except OUT and SENS	±20mA	Junction Temperature.....
Current into SENS and OUT	±340mA	-40°C to +150°C
		Storage Temperature Range.....
		-65°C to +150°C
		Lead Temperature (soldering, 10s)
		+300°C

Stresses beyond those listed under "Absolute Maximum Ratings" may cause permanent damage to the device. These are stress ratings only, and functional operation of the device at these or any other conditions beyond those indicated in the operational sections of the specifications is not implied. Exposure to absolute maximum rating conditions for extended periods may affect device reliability.

Package Thermal Characteristics (Note 1)

Junction-to-Ambient Thermal Resistance (θ _{JA})	55°C/W	Junction-to-Case Thermal Resistance (θ _{JC})	25°C/W
---	--------	--	--------

Note 1: Package thermal resistances were obtained using the method described in JEDEC specification JESD51-7, using a four-layer board. For detailed information on package thermal considerations, refer to www.maximintegrated.com/thermal-tutorial.

Electrical Characteristics

(V_{IN} = +9V to +18V, T_A = T_J = T_{MIN} to T_{MAX}, unless otherwise noted. Typical values are at T_A = +25°C.)

PARAMETER	SYMBOL	CONDITIONS	MIN	TYP	MAX	UNITS
GENERAL						
Operating Input Voltage Range	V _{IN}		5		18	V
Quiescent Supply Current	I _{CC}	V _{SHDN} < 0.4V		0.6	1.2	mA
Shutdown Supply Current	I _{SD}	V _{SHDN} > 1.7V, T _A = +25°C			5	µA
(V _{IN} -V _{SENS}) to V _{AOUT} Gain	A _v	V _{AOUT} /(V _{IN} -V _{SENS})		13		V/V
AOUT Maximum Voltage		(V _{IN} -V _{SENS}) > 300mV		4.3		V
AOUT Zero-Current Output Voltage		(V _{IN} -V _{SENS}) = 0	340	400	460	mV
AOUT Voltage		I _{LOAD} = I _{SC} , (V _{IN} - V _{SENS}) = 100mV	1.5	1.7	1.9	V
		I _{LOAD} = 2 x I _{SC} , (V _{IN} -V _{SENS}) = 200mV	2.7	3	3.3	
AOUT Output Impedance	Z _{AOUT}			5		kΩ
Switch Dropout Voltage	V _D	Measured between SENS and OUT while sourcing 100mA			0.6	V
Thermal Shutdown Threshold	T _{SHDN}	Temperature rising	+150	164		°C
Thermal Shutdown Hysteresis	T _{HYST}			15		°C
Reference Output Voltage	V _{REF}		2.7	3	3.3	V
Reference Output Impedance	Z _{REF}			5		kΩ
THRESHOLDS						
Open-Load Current Threshold	I _{OL}	R _{SENSE} = 1Ω (V _{OLT} = 0.66V for the MAX16913 only)	10	20	30	mA
Nominal Open-Load Threshold Setting Range	V _{OLR}	(MAX16913A only)	10		50	mV
Short-Circuit Voltage Threshold	V _{SC}	R _{SENSE} = 1Ω	87	100	110	mV
Voltage between IN and SENS	V _{LIM}	At current limit, V _{IN} = 14V	173	200	225	mV
Overvoltage Shutdown Threshold	V _{OVLO}	V _{IN} rising	18	21	24	V
Overcurrent Blanking Time	t _{BLANK}		100	200		ms
Retry Time	t _{RETRY}		1500	3000		ms

Electrical Characteristics (continued)

($V_{IN} = +9V$ to $+18V$, $T_A = T_J = T_{MIN}$ to T_{MAX} , unless otherwise noted. Typical values are at $T_A = +25^\circ C$.)

PARAMETER	SYMBOL	CONDITIONS	MIN	TYP	MAX	UNITS
LOGIC LEVELS						
$\overline{SC}, \overline{OL}$ Output-Voltage Low	V_{OL}	Sink current = 1mA			0.4	V
$\overline{SC}, \overline{OL}$ Output-Leakage Current	I_{LEAK}	$V_{\overline{SC}} = V_{\overline{OL}} = 5V$		0.01		μA
SHDN Input Low Voltage	V_{IL}				0.4	V
SHDN Input High Voltage	V_{IH}		1.7			V
TIMING						
Startup Response Time	t_{ST}	SHDN falling edge to 90% of V_{IN} , no load		100		μs

Typical Operating Characteristics

($V_{IN} = 14V$, $R_{SENSE} = 1\Omega$, $T_A = +25^\circ C$, unless otherwise noted.)

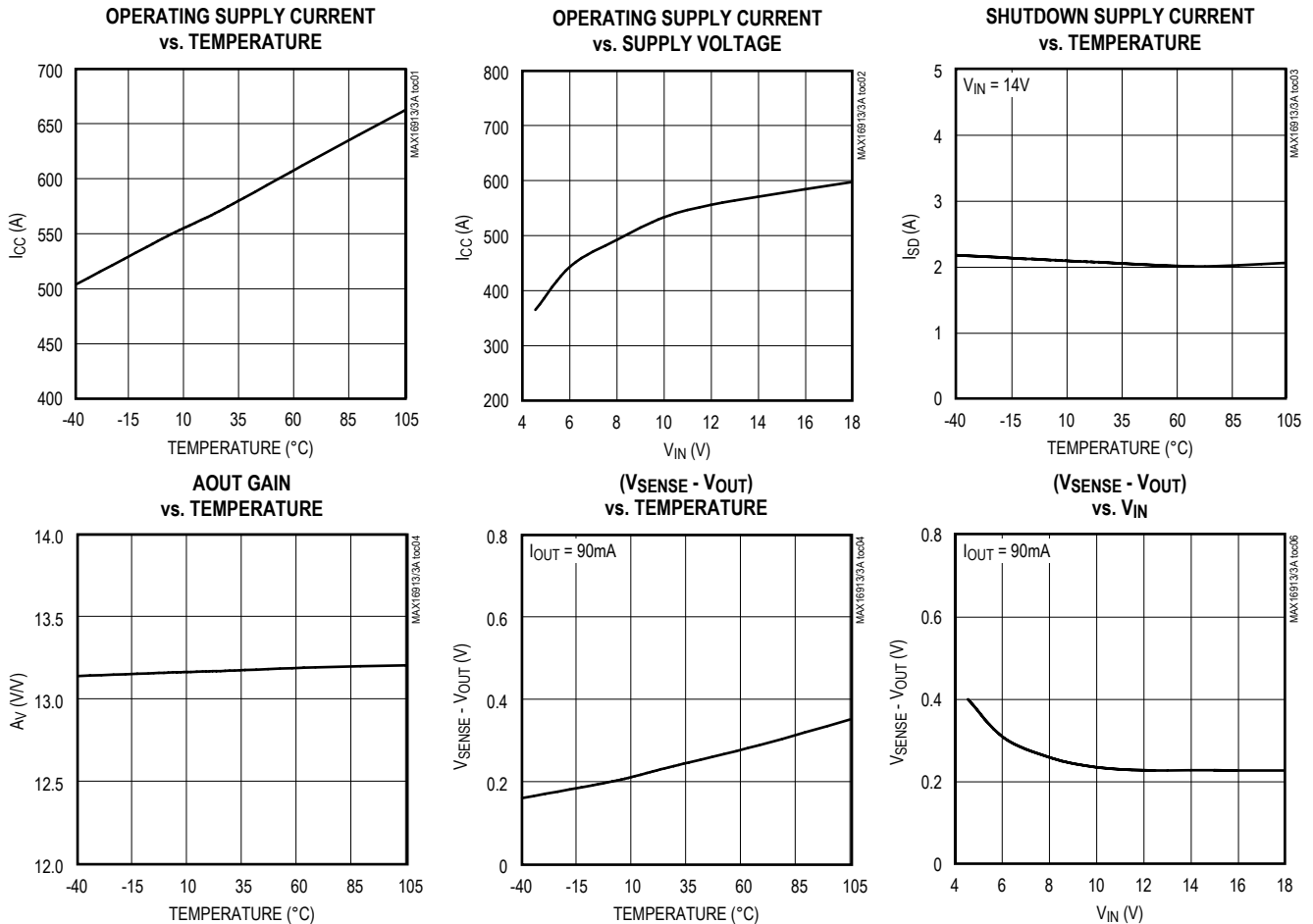

Typical Operating Characteristics (continued)

($V_{IN} = 14V$, $R_{SENSE} = 1\Omega$, $T_A = +25^\circ C$, unless otherwise noted.)

TOTAL CURRENT MEASUREMENT ERROR vs. ($V_{IN} - V_{SENSE}$)

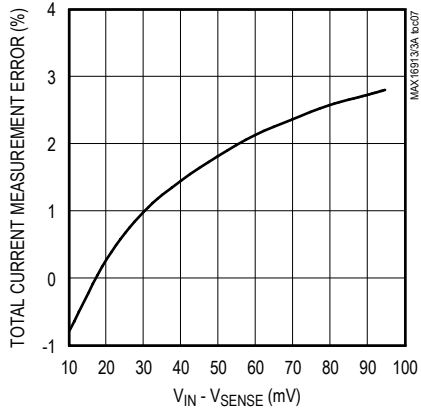

OVERCURRENT BLANKING TIME vs. TEMPERATURE

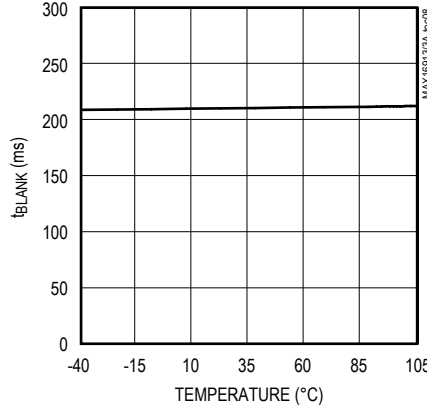

OVERCURRENT BLANKING TIME vs. V_{IN}

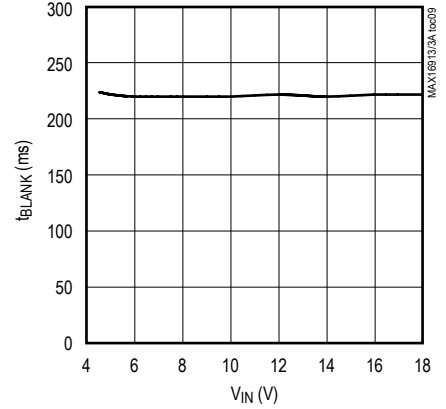

OVERCURRENT SHUTDOWN

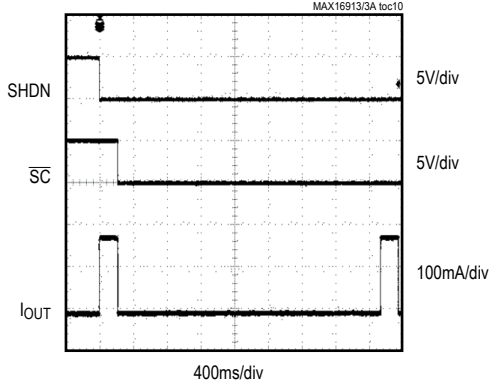

TURN-ON INTO CAPACITIVE LOAD (OUTPUT STAYS ON) ($C_{LOAD} = 1000\mu F$)

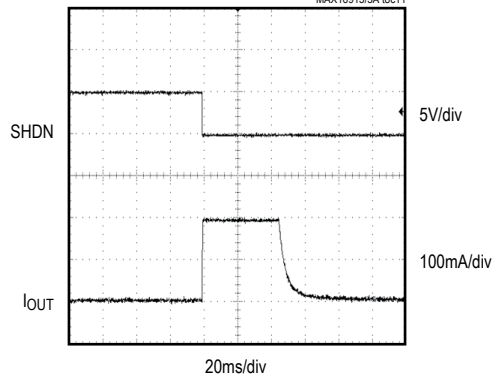

CURRENT-LIMIT VOLTAGE vs. V_{IN}

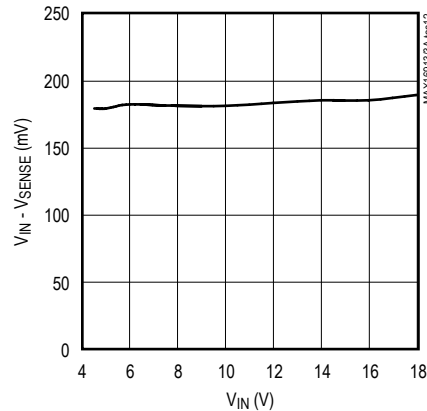

Pin Configuration

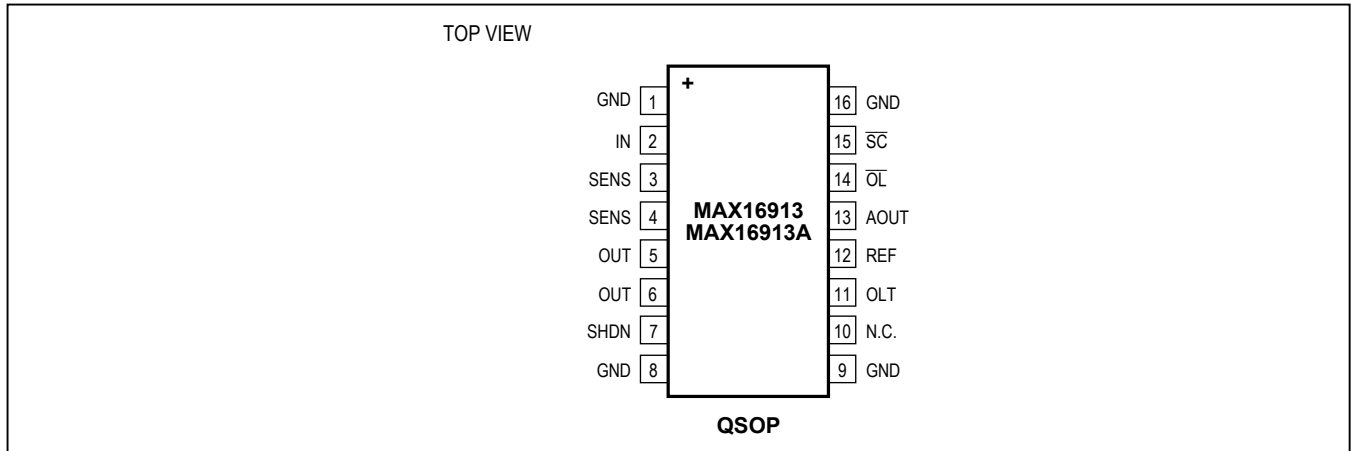

Pin Description

PIN	NAME	FUNCTION
1, 8, 9, 16	GND	Ground
2	IN	Input Voltage. Bypass IN to GND with a low-ESR ceramic capacitor with a minimum value of 0.1µF.
3, 4	SENS	Input to Current-Sense Amplifier. Connect the sense resistor between SENS and IN.
5, 6	OUT	Switch Output
7	SHDN	Active-High Control Input. Drive SHDN low to turn on the device.
10	N.C.	No Connection. Not internally connected.
11	OLT	Open-Load Threshold Setting Input. A resistive divider between REF, OLT, and GND sets the open-load current threshold (MAX16913A). For the MAX16913, connect OLT to GND.
12	REF	+3V Nominal Reference Output. Use a resistive divider between REF, OLT, and ground to set the open-load current threshold (MAX16913A). The output impedance of this voltage regulator is 5kΩ.
13	AOUT	Current-Monitor Voltage Output. AOUT can be used to measure the load current by means of an external ADC. The output impedance is 5kΩ.
14	OL	Open-Drain Open-Load Indicator Output. OL goes low when the load current is lower than the open-load current threshold, or when there is a short-to-battery fault. Connect OL to a 10kΩ pullup resistor. See Table 1.
15	SC	Open-Drain Short-Circuit Indicator Output. SC goes low when the load current is greater than the short-circuit current threshold or when there is a short-to-battery fault. Connect SC to a 10kΩ pullup resistor. See Table 1.

Detailed Description

The MAX16913/MAX16913A high-voltage, high-side, current-sense switches feature internal current limiting to prevent system damage due to fault conditions. The MAX16913/MAX16913A input voltage range extends from 5V to 18V, making them ideal for providing phantom power to remote radio-frequency low-noise amplifiers (LNAs) in automotive applications. High-side current monitoring does not interfere with the ground path of the load being measured, making these devices particularly useful in a wide range of high-voltage battery-powered systems.

The MAX16913/MAX16913A monitor the load current by means of a high-side current-sense amplifier and provide an analog output voltage proportional to that current at AOUT.

The devices combine a high-side current-sense amplifier, an internal switch, a +3V bandgap reference, and two open-drain fault indicator outputs. These features enable the design of remote power circuits with short-circuit, short-to-battery, and thermal protection. For the MAX16913A, the open-load threshold is externally adjustable using a resistive divider.

A fault-blanking feature enables the circuit to ignore momentary faults, such as those caused by initial charging of a capacitive load at turn-on, preventing false alarms to the system.

The MAX16913/MAX16913A provide an active-high control input (SHDN) to put the devices in low-power shutdown mode.

Current-Sense Amplifier

The integrated current-sense amplifier is a differential amplifier that amplifies the voltage between V_{IN} and V_{SENS} . A sense resistor (0.65Ωmin, 4.7Ωmax), R_{SENSE} , is connected across V_{IN} and V_{SENS} . When the load current passes through the sense resistor, a voltage drop develops across it. The current-sense amplifier amplifies this voltage.

The current-sense amplifier features an internally fixed gain of 13V/V (typ). The following equations show the relationship between the current-sense amplifier output voltage (AOUT) and load current:

$$I_{LOAD}(A) = \frac{(V_{IN} - V_{SENS})(V)}{R_{SENSE}(\Omega)}$$

$$V_{AOUT}(V) = [A_V(V/V) \times (V_{IN} - V_{SENS})(V)] + 0.4V$$

AOUT is the output of an internal buffer with a 5kΩ output impedance.

The AOUT voltage is clamped to typically 4.3V in order to avoid damage to external circuitry.

Load Protection

The MAX16913/MAX16913A monitor the load current through an external sense resistor and perform the following actions:

- If the monitored current is lower than the open-load current, the device signals open load (see the [Current-Sense Amplifier](#) section).
- If the monitored current is higher than the short-circuit current (I_{SC}), the device enters the short-circuit mode (see the [Short Circuit](#) section).

The devices also perform a short-to-battery detection every time the internal switch turns on (see the [Short-to-Battery Detection](#) section). In addition, thermal shutdown protects the MAX16913/MAX16913A from overheating (see the [Thermal Shutdown](#) section). Two open-drain outputs (\overline{OL} and \overline{SC}) indicate the device status (see Table 1).

Open Load

If the load current drops below the open-load current threshold, the \overline{OL} output asserts low. An open-load condition does not turn off the internal switch. The MAX16913 provides an internally fixed open-load threshold, while the MAX16913A features an adjustable open-load threshold.

For the MAX16913, when $(V_{IN} - V_{SENS})$ drops below 20mV (typ), the device signals open load.

For the MAX16913A, using a resistive divider between REF, the open-load threshold adjustment pin (OLT), and GND sets the open-load threshold (see the [Open-Load Threshold Selection](#) section).

Table 1. Status Truth Table

\overline{SC}	\overline{OL}	V_{AOUT}	DEVICE STATUS
0	0	0.4V	OUT Short-to-Battery
0	1	Cycling While Autoretrying	Short-Circuit Condition
1	0	0.4V	Open-Load Condition
1	1	$(V_{IN} - V_{SENS}) \times 13 + 0.4V$	Normal Operation

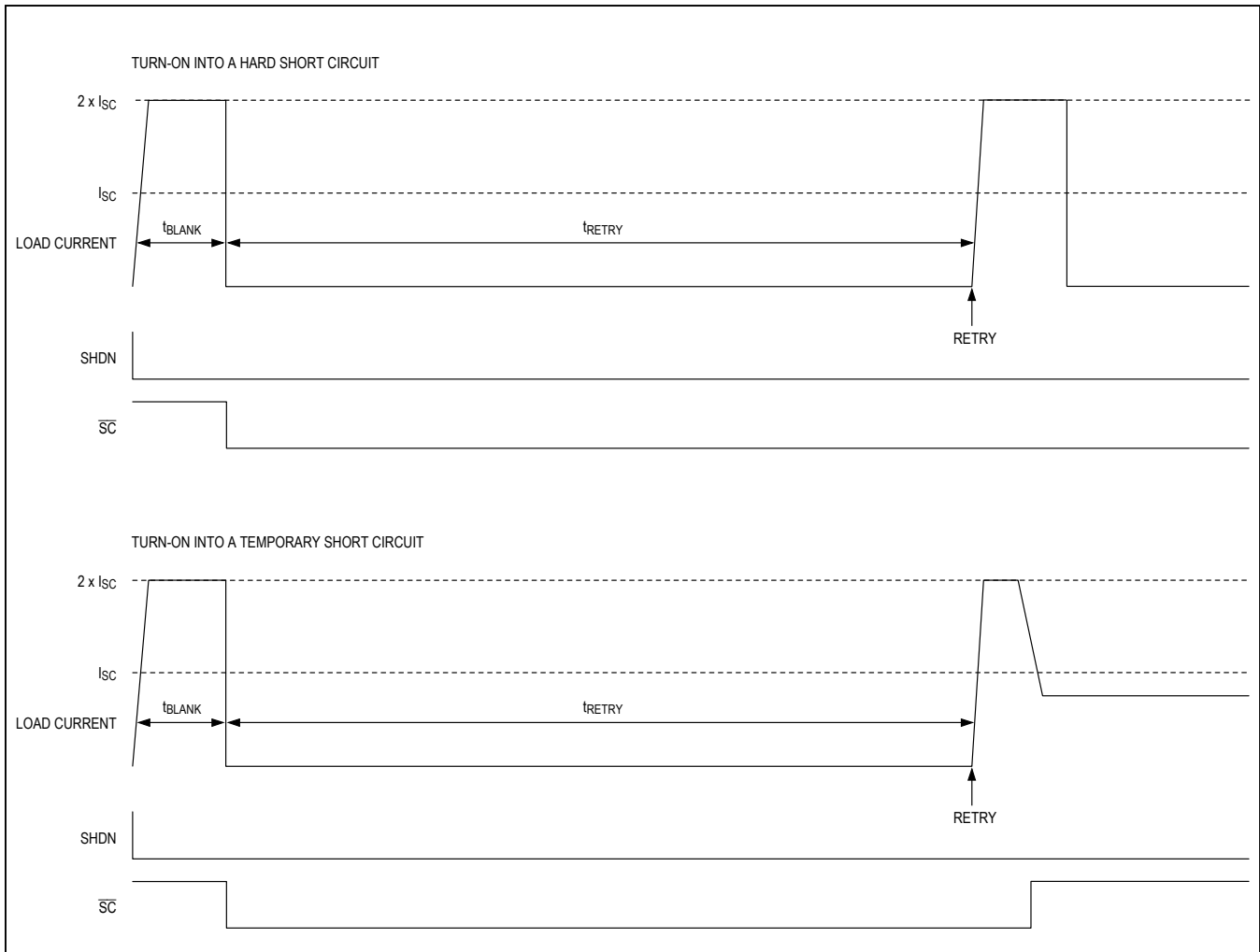

Figure 1. Short-Circuit Timing Diagram

Short Circuit

If the load current reaches the short-circuit current threshold (I_{SC}), the t_{BLANK} timer begins counting. During this period, the load current is limited to a value of twice the short-circuit current threshold ($2 \times I_{SC}$). If the short-circuit condition is present for t_{BLANK} , \overline{SC} asserts low and the internal switch turns off. The timer resets if the short-circuit condition disappears before the blanking time (t_{BLANK}) has elapsed. If the switch is turned off at the end of t_{BLANK} , a retry timer (t_{RETRY}) starts immediately after the blanking time has elapsed. During that time, the switch stays off. At the end of t_{RETRY} , the switch turns on again. If the fault still exists, the cycle repeats. If the fault has been removed, the switch stays on. During this cycle, \overline{SC} stays low. During retry when the switch is off, the current through the switch is zero (see Figure 1). If the load current is greater than I_{SC} , but does not reach the $2 \times$

I_{SC} threshold, the t_{BLANK} timer still begins counting (see Figure 2). The resistor across IN and SENSE sets I_{SC} to a typical value of $100\text{mV}/R_{SENSE} (\Omega)$. Blanking time and retry time have fixed values of 100ms (min) and 1500ms (min), respectively.

Short-to-Battery Detection

It may happen that OUT is shorted to the battery due to a fault in the system. The MAX16913/MAX16913A detect this failure by comparing the OUT voltage and the IN voltage before the switch turns on. Every time the switch turns on, such as at the end of the retry time, or once the thermal shutdown condition disappears, the short-to-battery detection is performed. At this point, if the device detects any failure, the switch stays off, and both \overline{SC} and \overline{OL} assert low (see Table 1).

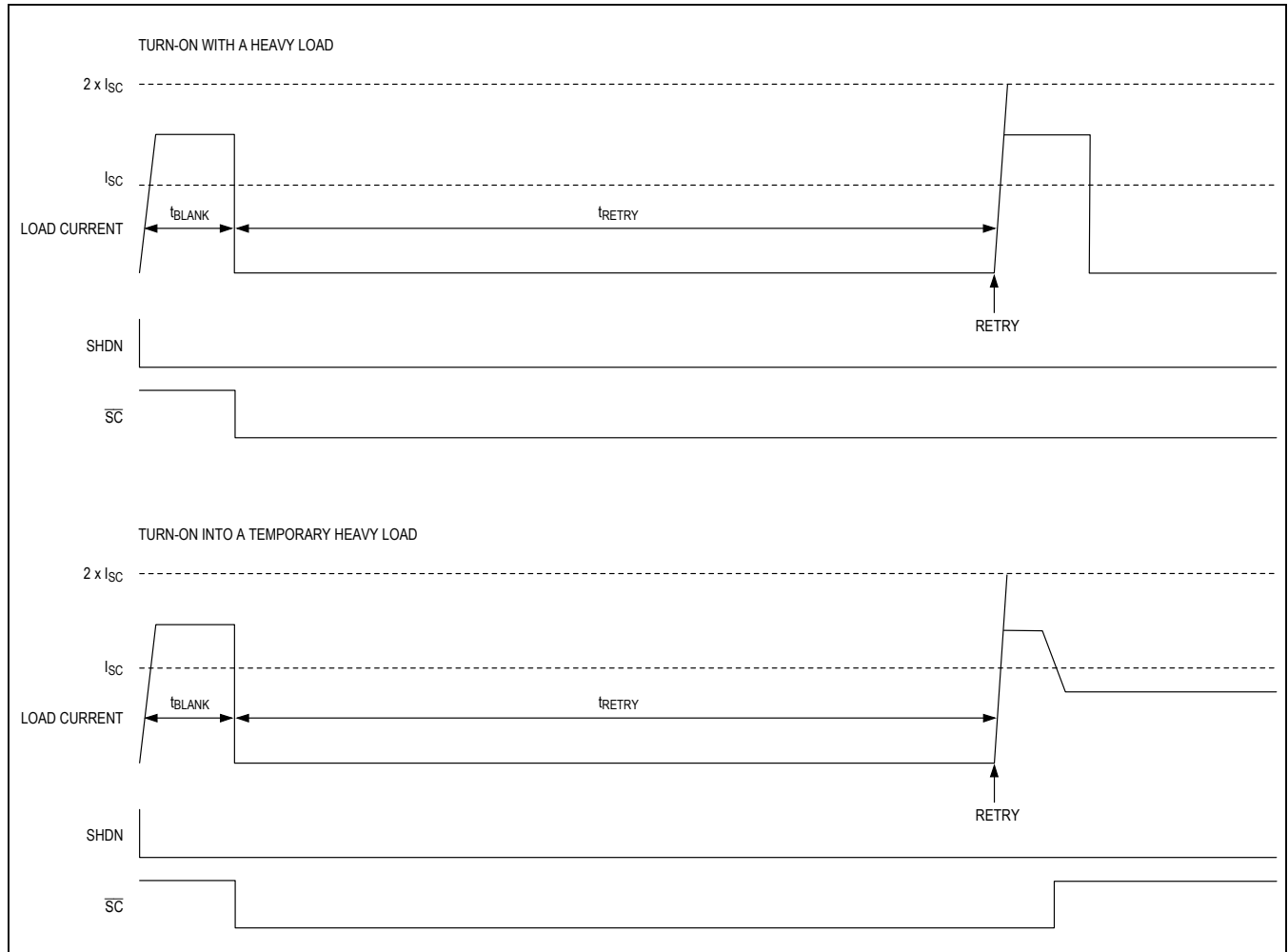

Figure 2. Overcurrent Timing Diagram

Thermal Shutdown

Thermal shutdown circuitry protects the devices from overheating. The switch turns off immediately when the junction temperature exceeds +150°C (min) (see Table 1). The switch turns on again after the device temperature drops by approximately 15°C (typ).

Shutdown (SHDN)

The MAX16913/MAX16913A feature an active-high control input (SHDN) to put the devices in a low-power shutdown mode. The devices turn off and consume only 5µA (max) of shutdown current when SHDN is driven high.

Undervoltage and Overvoltage Lockout

The MAX16913/MAX16913A include undervoltage circuitry (UVLO) to prevent erroneous switch operation when the

input voltage goes below approximately 4.25V during startup and brownout conditions. Input voltages of less than 4.25V inhibit operation of the device by turning off the internal charge pump and the switch. These devices also feature an overvoltage lock-out (OVLO) threshold of +21V (typ). When V_{IN} is greater than V_{OVLO} , the device immediately turns off the switch and the internal charge pump.

Internal Reference

The MAX16913/MAX16913A feature a +3V bandgap reference output, stable over supply voltage and temperature. For the MAX16913A, the reference output is connected to the resistive divider which sets the open-load threshold. The output impedance of the internal reference is 5kΩ (typ).

Applications Information

Choosing the Sense Resistor

Ideally, the maximum load current develops the full-scale sense voltage across the current-sense resistor. The current-sense amplifier output voltage is given by:

$$V_{AOUT} (V) = [(V_{IN} - V_{SENS})(V) \times A_V(V/V)] + 0.4(V)$$

where V_{AOUT} is the output voltage of the current-sense amplifier, and A_V is the gain of the current-sense amplifier of 13V/V (typ). Calculate the maximum value for R_{SENSE} so that the differential voltage across IN and SENS does not exceed the minimum full-scale sense voltage (87mV):

$$R_{SENSE}(\Omega) = \frac{V_{DIFF(MIN)}(V)}{I_{LOAD(FULL-SCALE)}(A)}$$

where $V_{DIFF(MIN)} = V_{IN} - V_{SENS} = 87\text{mV}$ minimum at maximum load current.

Use resistors specified for current-sensing applications with a minimum resistance value of 0.65 Ω , and the maximum resistance value of 4.7 Ω . Keep inductance low if I_{SENSE} has a large high-frequency component. Wire-wound resistors have the highest inductance, while metal film is somewhat better. Low-inductance metal-film resistors are also available. Instead of being spiral wrapped around a core, as in metal-film or wire-wound resistors, they are a straight band of metal and are available in values under 1 Ω . Because of the high current that flows through R_{SENSE} , avoid parasitic trace resistance from causing errors in the sense voltage.

Open-Load Threshold Selection

For the MAX16913A, a resistive divider between REF, OLT, and GND sets the open-load threshold. See Figure 3.

Use the following formula to set the desired open-load threshold:

$$\frac{R_2(k\Omega)}{(R_1+R_2)(k\Omega)} = \frac{(R_{SENSE}(\Omega) \times I_{OL}(A) \times A_V(V/V)) + 0.4V}{V_{REF}(V)}$$

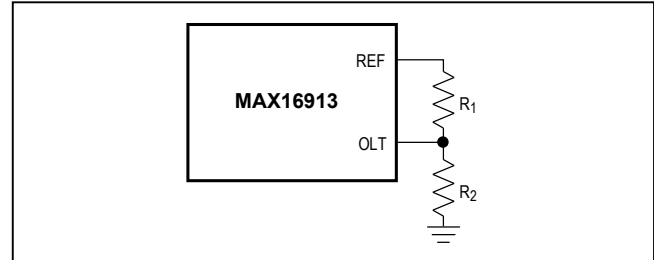

Figure 3. Open-Load Threshold Selection

where I_{OL} is the desired open-load current threshold; A_V is the current-sense amplifier gain (13V/V typ), and V_{REF} is the reference voltage (+3V typ). The sum of R_1 and R_2 should be large enough so that the output impedance of the internal reference (5k Ω) is negligible compared to the sum of R_1 and R_2 , and has a minimum effect on the accuracy of the adjusted open-load threshold.

For example, to set the open-load threshold at 10mA, using a 1 Ω sense resistor, use the following method to calculate the value of R_1 and R_2 :

$$\frac{R_2(k\Omega)}{(R_1+R_2)(k\Omega)} = \frac{(1(\Omega) \times 0.01(A) \times 13(V/V)) + 0.4V}{3(V)} = 0.177$$

Choose $R_1 = 470\text{k}\Omega$ and calculate R_2 as 101k Ω .

Input Capacitor

Connect a low-leakage ceramic capacitor from IN to GND to limit the input voltage drop during momentary output short-circuit conditions, and to protect the device against transients due to inductance in the IN line. For example, use at least a 0.1 μF ceramic capacitor if the input inductance (including any stray inductance) is estimated to be 20 μH . Larger capacitor values reduce the voltage undershoot at the input.

Output Capacitor

In an analogous fashion to the input capacitor, an output capacitor protects the device against transients due to any series inductance in the output. Under no conditions should the OUT pin voltage go below -0.3V as specified in the *Absolute Maximum Ratings*. If a capacitor alone is not sufficient to avoid large negative transients on OUT, then a Schottky diode should be used to clamp transients that go below ground. With a 100µH output series inductor, a 220µF output capacitor is needed to eliminate potential problems. With larger inductor values or smaller capacitors, a Schottky clamp diode will be necessary.

Layout and Thermal Dissipation

To optimize the switch response time to output short-circuit condition, it is very important to keep all traces as short as possible to reduce the effect of undesirable parasitic inductance. Place input and output capacitors as close as possible to the device (no more than 5mm).

IN and OUT must be connected with wide short traces to the power bus. During normal operation, the power dissipation is small and the package temperature change is minimal. If the output is continuously shorted to ground at the maximum supply voltage, the devices are protected because the total power dissipated during the short is scaled down by the duty cycle imposed by the protection:

$$P_{(MAX)} = \frac{V_{IN(MAX)} \times I_{OUT(MAX)} \times t_{BLANK}}{t_{RETRY} + t_{BLANK}}$$

MAX16913 Functional Diagram

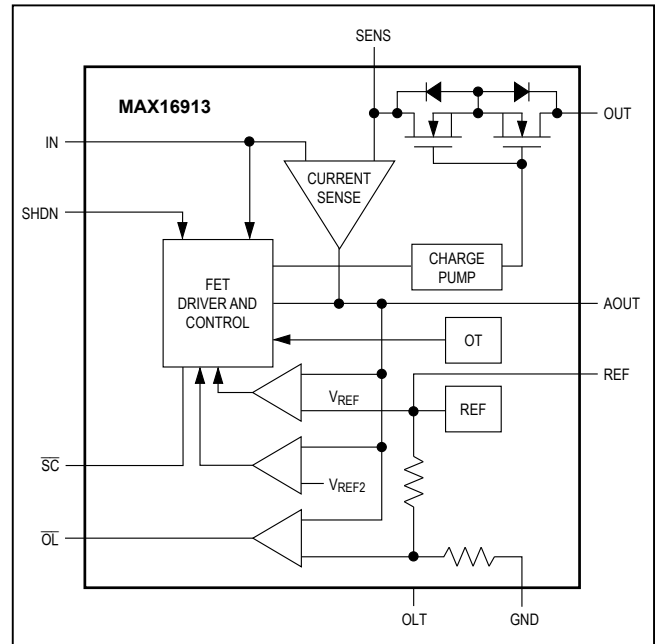

MAX16913A Functional Diagram

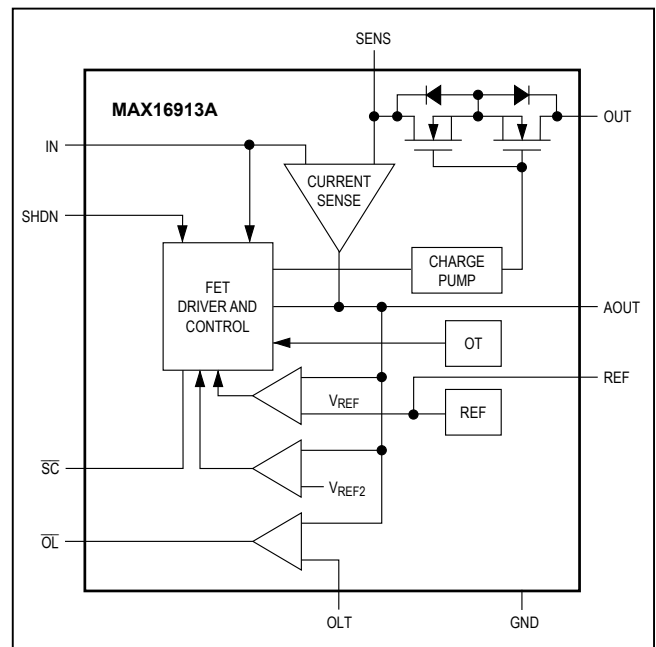

Chip Information

PROCESS: BICMOS

Package Information

For the latest package outline information and land patterns (footprints), go to www.maximintegrated.com/packages. Note that a "+", "#", or "-" in the package code indicates RoHS status only. Package drawings may show a different suffix character, but the drawing pertains to the package regardless of RoHS status.

PACKAGE TYPE	PACKAGE CODE	OUTLINE NO.	LAND PATTERN NO.
16 QSOP	E16+8F	21-0112	90-0167

Ordering Information

PART	TEMP RANGE	PIN-PACKAGE	OPEN-LOAD THRESHOLD
MAX16913GEE+	-40°C to +105°C	16 QSOP	Internally Set
MAX16913AGEE+	-40°C to +105°C	16 QSOP	Externally Adjustable
MAX16913AGEE/V+*	-40°C to +105°C	16 QSOP	Externally Adjustable

+Denotes a lead-free/RoHS-compliant package.

*V denotes an automotive qualified part.

Revision History

REVISION NUMBER	REVISION DATE	DESCRIPTION	PAGES CHANGED
0	7/08	Initial release	—
1	8/15	Deleted MAX16913GEE/V+ from <i>Ordering Information</i> , updated <i>Package Information</i> , and rebranded data sheet	1, 10

For pricing, delivery, and ordering information, please contact Maxim Direct at 1-888-629-4642, or visit Maxim Integrated's website at www.maximintegrated.com.

Maxim Integrated cannot assume responsibility for use of any circuitry other than circuitry entirely embodied in a Maxim Integrated product. No circuit patent licenses are implied. Maxim Integrated reserves the right to change the circuitry and specifications without notice at any time. The parametric values (min and max limits) shown in the Electrical Characteristics table are guaranteed. Other parametric values quoted in this data sheet are provided for guidance.



Компания «ЭлектроПласт» предлагает заключение долгосрочных отношений при поставках импортных электронных компонентов на взаимовыгодных условиях!

Наши преимущества:

- Оперативные поставки широкого спектра электронных компонентов отечественного и импортного производства напрямую от производителей и с крупнейших мировых складов;
- Поставка более 17-ти миллионов наименований электронных компонентов;
- Поставка сложных, дефицитных, либо снятых с производства позиций;
- Оперативные сроки поставки под заказ (от 5 рабочих дней);
- Экспресс доставка в любую точку России;
- Техническая поддержка проекта, помощь в подборе аналогов, поставка прототипов;
- Система менеджмента качества сертифицирована по Международному стандарту ISO 9001;
- Лицензия ФСБ на осуществление работ с использованием сведений, составляющих государственную тайну;
- Поставка специализированных компонентов (Xilinx, Altera, Analog Devices, Intersil, Interpoint, Microsemi, Aeroflex, Peregrine, Syfer, Eurofarad, Texas Instrument, Miteq, Cobham, E2V, MA-COM, Hittite, Mini-Circuits, General Dynamics и др.);

Помимо этого, одним из направлений компании «ЭлектроПласт» является направление «Источники питания». Мы предлагаем Вам помощь Конструкторского отдела:

- Подбор оптимального решения, техническое обоснование при выборе компонента;
- Подбор аналогов;
- Консультации по применению компонента;
- Поставка образцов и прототипов;
- Техническая поддержка проекта;
- Защита от снятия компонента с производства.



Как с нами связаться

Телефон: 8 (812) 309 58 32 (многоканальный)

Факс: 8 (812) 320-02-42

Электронная почта: org@eplast1.ru

Адрес: 198099, г. Санкт-Петербург, ул. Калинина, дом 2, корпус 4, литера А.