

ESD Suppressor

Type: **EZAEG**

EZAEG1A, 2A, 3A



■ Features

- ESD protection of high-speed data lines
- Low capacitance
(1608 size : 0.1 pF, 1005 size : 0.05 pF, 0603 size : 0.04 pF)
- Good ESD suppression characteristics
- Good ESD withstanding

■ Recommended Applications

- High-Speed Data Lines
(HDMI, Serial ATA, USB, IEEE1394, Display Port)
- Antenna Circuitry and RF Modules (Cellular Phones)

■ Explanation of Part Numbers

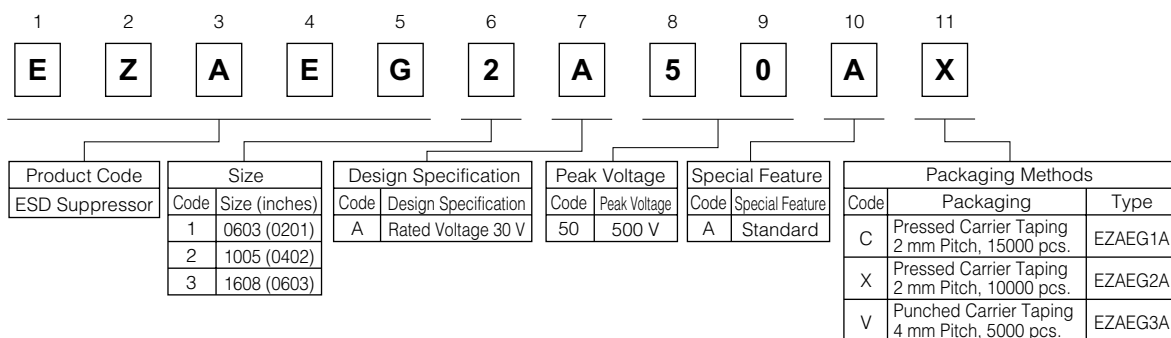

■ Construction

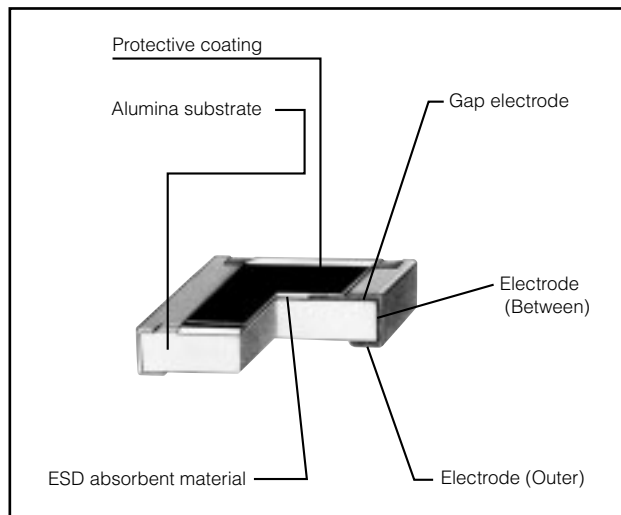

■ Dimensions in mm (not to scale)

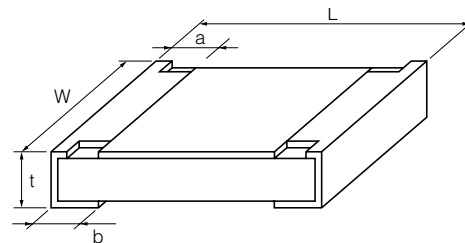

Type (inches)	Dimensions (mm)					Mass (Weight) [g/1000 pcs.]
	L	W	a	b	t	
EZAEG1A (0201)	0.60±0.03	0.30±0.03	0.15±0.10	0.15±0.10	0.23±0.03	0.12
EZAEG2A (0402)	1.00±0.10	0.50±0.05	0.20±0.10	0.25±0.10	0.38±0.05	0.6
EZAEG3A (0603)	1.60±0.15	0.80±0.15	0.30±0.20	0.30±0.20	0.50±0.10	2.2

■ Circuit Configuration

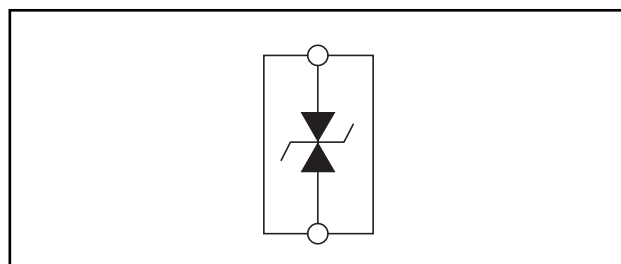

■ Ratings

Type (inches)	Capacitance ⁽¹⁾	Peak Voltage ⁽²⁾	Clamping Voltage ⁽³⁾	Rated Voltage	Category Temperature Range (Operating Temperature Range)
EZAEG1A (0201)	0.04 ^{+0.04} _{-0.03} pF	500 V max. (350 V typ.)	100 V max.	30 V max	-55 to +125 °C
EZAEG2A (0402)	0.05 ^{+0.05} _{-0.04} pF				
EZAEG3A (0603)	0.10 ^{+0.10} _{-0.08} pF				

(1) Capacitance = The capacitance value shall be measured under the conditions specified below.

Frequency : 1 MHz±10 %, Voltage : 1 Vrms±0.2 Vrms, Temperature : 25 °C±2 °C

(2) Peak Voltage = The peak voltage value shall be measured under the following conditions. ESD test conditions : IEC61000-4-2, 8 kV contact discharge

(3) Clamping Voltage = The clamping voltage value shall be measured at 30 ns after initiation of pulse and measured under the conditions specified below. ESD test conditions : IEC61000-4-2, 8 kV contact discharge

■ Frequency Characteristics

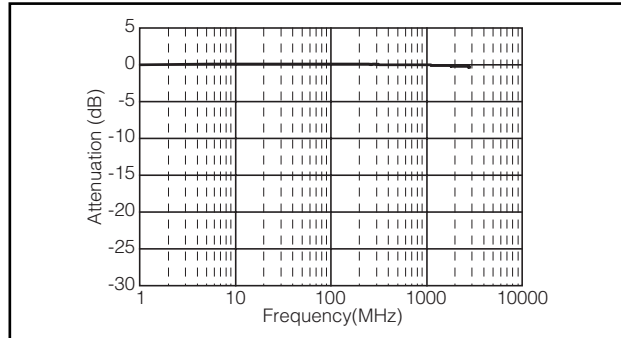

■ ESD Suppression Voltage Waveform

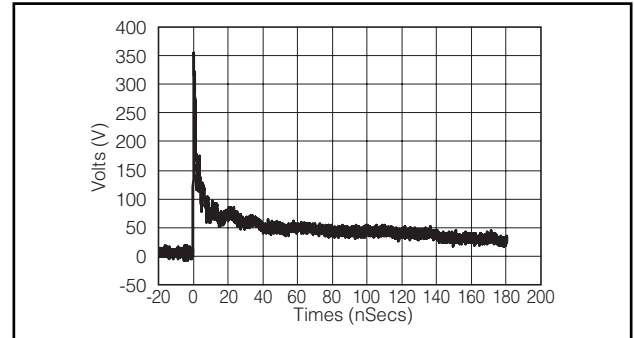

■ Typical Circuits Requiring Protection

● HDMI circuit

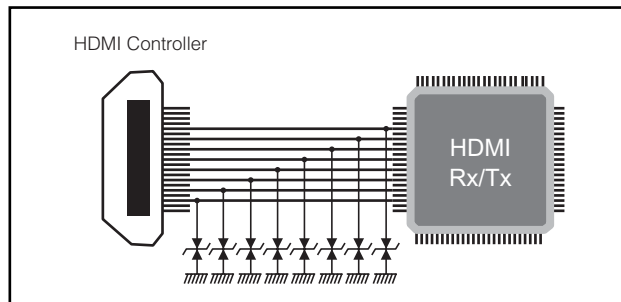

● Antenna circuit

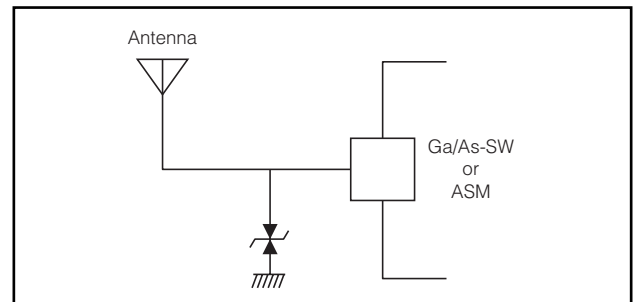

■ Packaging Methods (Taping)

● Standard Quantity

Type	Kind of Taping	Pitch (P ₁)	Quantity
EZAEG1A	Pressed Carrier Taping	2 mm	15000 pcs./reel
EZAEG2A			10000 pcs./reel
EZAEG3A	Punched Carrier Taping	4 mm	5000 pcs./reel

● Carrier Taping

(Unit : mm)

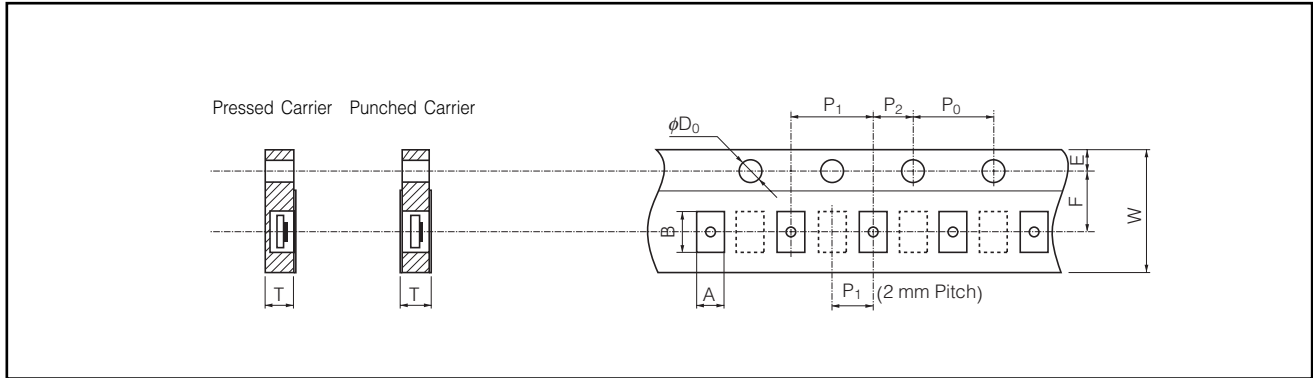

Type	A	B	W	F	E	P_1	P_2	P_0	ϕD_0	T
EZAEG1A	$0.38^{+0.05}$	$0.68^{+0.05}$	$8.00^{+0.20}$	$3.50^{+0.05}$	$1.75^{+0.10}$	$2.00^{+0.10}$	$2.00^{+0.05}$	$4.00^{+0.10}$	$1.50^{+0.10}$	$0.42^{+0.05}$
EZAEG2A	$0.70^{+0.05}$	$1.20^{+0.05}$				$4.00^{+0.10}$				$0.60^{+0.05}$
EZAEG3A	$1.10^{+0.10}$	$1.90^{+0.10}$				$0.70^{+0.05}$				

● Taping Reel

(Unit : mm)

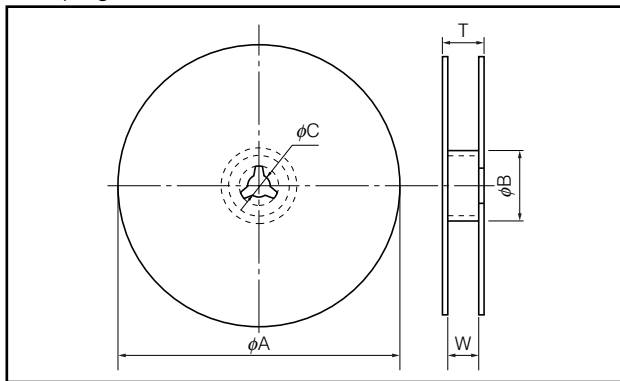

Type	ϕA	ϕB	ϕC	W	T
EZAEG1A	$180.0^{+0}_{-3.0}$	60 min.	$13.0^{+1.0}$	$9.0^{+1.0}$	$11.4^{+1.0}$
EZAEG2A					
EZAEG3A					

■ Recommended Land Pattern

In case of flow soldering, the land width must be smaller than the ESD Suppressor width to properly control the solder amount properly. Generally, the land width should be 0.7 to 0.8 times (W) of the width of ESD Suppressor. In case of reflow soldering, solder amount can be adjusted, therefore the land width should be set to 1.0 to 1.3 times ESD Suppressor width (W).

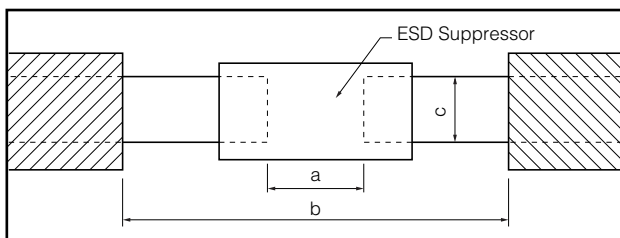

Type (inches)	Dimensions (mm)		
	a	b	c
EZAEG1A (0201)	0.3 to 0.4	0.8 to 0.9	0.25 to 0.35
EZAEG2A (0402)	0.5 to 0.6	1.4 to 1.6	0.4 to 0.6
EZAEG3A (0603)	0.7 to 0.9	2.0 to 2.2	0.8 to 1.0

Recommended Soldering Conditions

Recommendations and precautions are described below.

- Recommended soldering conditions for reflow
 - Reflow soldering shall be performed a maximum of two times.
 - Please contact us for additional information when used in conditions other than those specified.
 - Please measure the temperature of the terminals and study every kind of solder and printed circuit board for solderability before actual use.

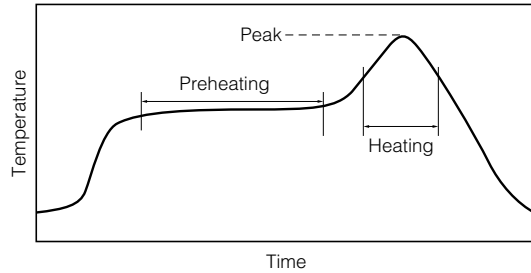

For soldering (Example : Sn/Pb)

	Temperature	Time
Preheating	140 °C to 160 °C	60 s to 120 s
Main heating	Above 200 °C	30 s to 40 s
Peak	235 ± 5 °C	max. 10 s

For lead-free soldering (Example : Sn/Ag/Cu)

	Temperature	Time
Preheating	150 °C to 180 °C	60 s to 120 s
Main heating	Above 230 °C	30 s to 40 s
Peak	max. 260 °C	max. 10 s

⚠ Safety Precautions

The following are precautions for individual products. Please also refer to the precautions common to EMI Filters, ESD Suppressors, Fuses, and MR Sensors shown on page EL113 of this catalog.

1. If a large electric surge (especially, one which is larger than an ESD) is expected to be applied, be sure to test and confirm proper ESD Suppressor (hereafter called the suppressors) functionality when mounted on your board. When the applied load is more than the allowable rated power under normal load conditions, it may impair performance and/or the reliability of the suppressors. Never exceed the rated power. If the product will be used under these special conditions, be sure to contact a Panasonic representative first.
2. Do not use halogen-based or other high-activity flux. Otherwise, the residue may impair the suppressors' performance and/or reliability.
3. When soldering with a soldering iron, never touch the suppressors' bodies with the tip of the soldering iron. When using a soldering iron with a high temperature tip, finish soldering as quickly as possible (within three seconds at 350 °C max.).
4. Avoid excessive bending of printed circuit boards in order to protect the suppressors from abnormal stress.
5. Do not immerse the suppressors in solvent for a long time. Before using solvent, carefully check the effects of immersion.

⚠ Safety Precautions (Common precautions for ESD Suppressors)

- When using our products, no matter what sort of equipment they might be used for, be sure to make a written agreement on the specifications with us in advance. The design and specifications in this catalog are subject to change without prior notice.
- Do not use the products beyond the specifications described in this catalog.
- This catalog explains the quality and performance of the products as individual components. Before use, check and evaluate their operations when installed in your products.
- Install the following systems for a failsafe design to ensure safety if these products are to be used in equipment where a defect in these products may cause the loss of human life or other significant damage, such as damage to vehicles (automobile, train, vessel), traffic lights, medical equipment, aerospace equipment, electric heating appliances, combustion/gas equipment, rotating equipment, and disaster/crime prevention equipment.
- * Systems equipped with a protection circuit and a protection device
- * Systems equipped with a redundant circuit or other system to prevent an unsafe status in the event of a single fault

(1) Precautions for use

- These products are designed and manufactured for general and standard use in general electronic equipment (e.g. AV equipment, home electric appliances, office equipment, information and communication equipment)
- These products are not intended for use in the following special conditions. Before using the products, carefully check the effects on their quality and performance, and determine whether or not they can be used.
 1. In liquid, such as water, oil, chemicals, or organic solvent
 2. In direct sunlight, outdoors, or in dust
 3. In salty air or air with a high concentration of corrosive gas, such as Cl₂, H₂S, NH₃, SO₂, or NO₂
 4. Electromagnetic Environment
 - Avoid any environment where strong electromagnetic waves exist.
 5. In an environment where these products cause dew condensation
 6. Sealing or coating of these products or a printed circuit board on which these products are mounted, with resin or other materials
- These products generate Joule heat when energized. Carefully position these products so that their heat will not affect the other components.
- Carefully position these products so that their temperatures will not exceed the category temperature range due to the effects of neighboring heat-generating components. Do not mount or place heat-generating components or inflammables, such as vinyl-coated wires, near these products .
- Note that non-cleaning solder, halogen-based highly active flux, or water-soluble flux may deteriorate the performance or reliability of the products.
- Carefully select a flux cleaning agent for use after soldering. An unsuitable agent may deteriorate the performance or reliability. In particular, when using water or a water-soluble cleaning agent, be careful not to leave water residues. Otherwise, the insulation performance may be deteriorated.

(2) Precautions for storage

The performance of these products, including the solderability, is guaranteed for a year from the date of arrival at your company, provided that they remain packed as they were when delivered and stored at a temperature of 5 °C to 35 °C and a relative humidity of 45 % to 85 %.

Even within the above guarantee periods, do not store these products in the following conditions. Otherwise, their electrical performance and/or solderability may be deteriorated, and the packaging materials (e.g. taping materials) may be deformed or deteriorated, resulting in mounting failures.

1. In salty air or in air with a high concentration of corrosive gas, such as Cl₂, H₂S, NH₃, SO₂, or NO₂
2. In direct sunlight

<Package markings>

Package markings include the product number, quantity, and country of origin. In principle, the country of origin should be indicated in English.



Компания «ЭлектроПласт» предлагает заключение долгосрочных отношений при поставках импортных электронных компонентов на взаимовыгодных условиях!

Наши преимущества:

- Оперативные поставки широкого спектра электронных компонентов отечественного и импортного производства напрямую от производителей и с крупнейших мировых складов;
- Поставка более 17-ти миллионов наименований электронных компонентов;
- Поставка сложных, дефицитных, либо снятых с производства позиций;
- Оперативные сроки поставки под заказ (от 5 рабочих дней);
- Экспресс доставка в любую точку России;
- Техническая поддержка проекта, помощь в подборе аналогов, поставка прототипов;
- Система менеджмента качества сертифицирована по Международному стандарту ISO 9001;
- Лицензия ФСБ на осуществление работ с использованием сведений, составляющих государственную тайну;
- Поставка специализированных компонентов (Xilinx, Altera, Analog Devices, Intersil, Interpoint, Microsemi, Aeroflex, Peregrine, Syfer, Eurofarad, Texas Instrument, Miteq, Cobham, E2V, MA-COM, Hittite, Mini-Circuits, General Dynamics и др.);

Помимо этого, одним из направлений компании «ЭлектроПласт» является направление «Источники питания». Мы предлагаем Вам помощь Конструкторского отдела:

- Подбор оптимального решения, техническое обоснование при выборе компонента;
- Подбор аналогов;
- Консультации по применению компонента;
- Поставка образцов и прототипов;
- Техническая поддержка проекта;
- Защита от снятия компонента с производства.



Как с нами связаться

Телефон: 8 (812) 309 58 32 (многоканальный)

Факс: 8 (812) 320-02-42

Электронная почта: org@eplast1.ru

Адрес: 198099, г. Санкт-Петербург, ул. Калинина, дом 2, корпус 4, литера А.