

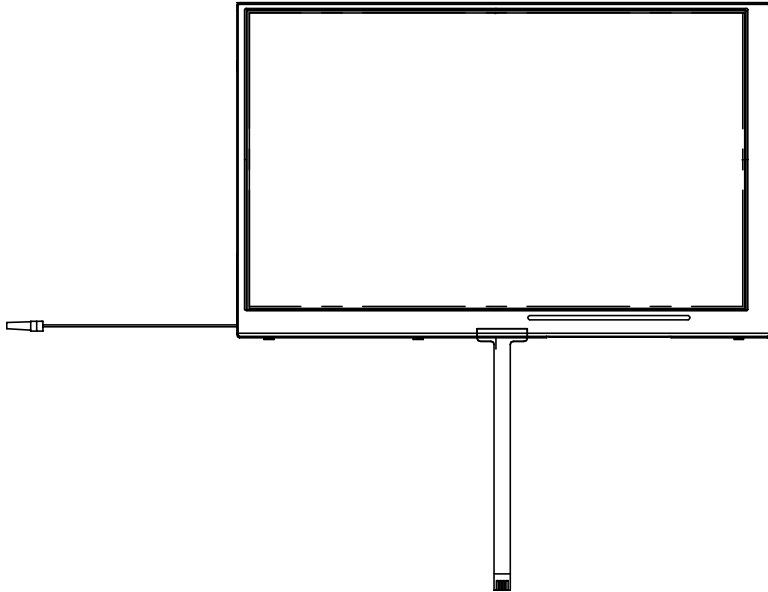

PRODUCT SPECIFICATION

HDA700LT-2S

7", TFT WVGA (800X480) COLOR
LCD DISPLAY MODULE



HANTRONIX, INC. 10080 BUBB RD. CUPERTINO, CA 95014	Q.A.: Z.W.	REV.: 1.0	HDA700LT-2S	SHEET 1 OF 13 DATE: 5/18/12
--	---------------	--------------	-------------	--------------------------------

1. SUMMARY

This technical specification applies to 7" TFT-LCD module with a LED Backlight unit and 40-pin TTL interface. This module supports 800*R.G.B x 480 WVGA mode and can displ 262,144 colors.

2. FEATURES

- Thin and Light Weight.
- WVGA(800x480 pixels) resolution.
- 3.3 V TTL interface

3. GENERAL SPECIFICATIONS

Parameter	Specifications	Unit	
Screen size	7"(Diagonal)	inch	
Display Format	800 RGB x 480	dot	
Active area	152.4x91.44	mm	
Pixel size	190.5 x 190.5	um	
Surface treatment	Anti-glare		
Color Saturation (NTSC)	45	%	
Pixel Configuration	RGB Vertical Stripe		
Outline dimension	165(W) x 104.44(H) x 6.6 (D)	mm	
Weight	TBD	g	
View Angle direction (Gray inversion)	6 o'clock		
Temperature Range	Operation	-20~70	°C
	Storage	-30~80	°C

4. ABSOLUTE MAXIMUM RATINGS (GND=0V)

Item	Symbol	Condition	Min.	Max.	Unit	Remark
Power Voltage	Vcc	GND=0	-0.3	6	V	-
Input logic voltage	Vi	GND=0	-0.3	Vcc+0.3	V	Note1

Note 1: DCLK, DE, R0~ R5, G0~ G5, B0~ B5

HANTRONIX, INC. 10080 BUBB RD. CUPERTINO, CA 95014	Q.A.:	REV.:	HDA700LT-2S	SHEET 2 OF 13
	Z.W.	1.0		DATE: 5/18/12

5. ELECTRICAL CHARACTERISTICS

5.1 Recommended Operation condition (GND=0, Ta=25)

Parameter		Symbol	Rating			Unit	Condition
			Min.	Typ.	Max.		
Power Supply Voltage		Vcc	3	3.3	3.6	V	
Input logic voltage	High Level	VIH	0.7Vcc	-	Vcc	V	Note 1
	Low Level	VIL	0	-	0.3Vcc	V	Note 1

Note 1: DCLK, DE, R0~ R5, G0~ G5, B0~ B5.

5.2 LED Driving Conditions

Ta = 25

Parameter	Symbol	Min.	Typ.	Max.	Unit	Remark
LED current	I _{LED}	-	160	-	mA	Note 1
LED voltage	V _{LED}	-	9.9	-	V	
LED Life Time	-	10,000	20,000	-	Hr	Note 2

Note 1: There are 8Groups LED shown as below, V_{led}=9.9V, I_{led}=160mA

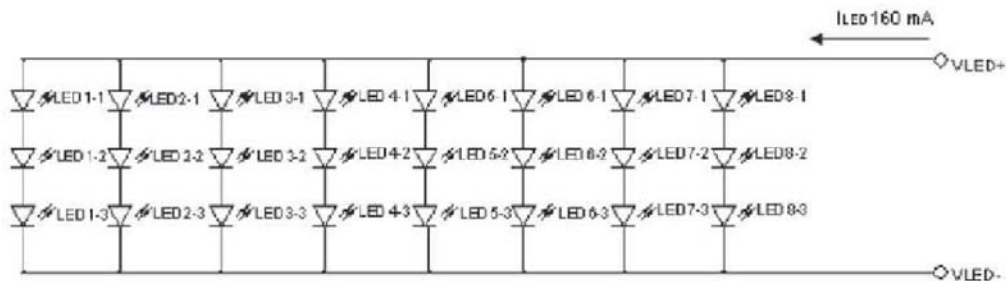

Note 2 : Brightness to be decreased to 50% of the initial value.

5.3 TFT-LCD current consumption

Parameter	Symbol	Rating			Unit	Condition
		Min.	Typ.	Max		
LCD power current	I _{cc}	--	200	260	mA	black pattern
LED power current	I _{LED}	--	160	200	mA	

HANTRONIX, INC.
10080 BUBB RD.
CUPERTINO, CA 95014

Q.A.:
Z.W.

REV.:
1.0

HDA700LT-2S

SHEET 3 OF 13

DATE:
5/18/12

6. AC CHARACTERISTICS

6.1 AC Electrical CHARACTERISTICS

Parameter	Symbol	Rating			Unit
		Min.	Typ.	Max	
Data setup time	T _{dsu}	6	-	-	ns
Data hold time	T _{dhd}	6	-	-	ns
DE setup time	T _{esu}	6	-	-	ns
CLK frequency	F _{CPH}	29.40	33.26	42.48	MHz
CLK period	T _{CPH}	23.54	30.06	34.01	ns
CLK pulse duty	T _{CWH}	40	50	60	%
CLK pulse duty	T _{CWL}	40	50	60	%
DE period	T _{DEH+TDEL}	1000	1056	1200	T _{CPH}
DE pulse width	T _{DEH}	-	800	-	T _{CPH}
DE frame blanking	T _{DEB}	10	45	110	T _{DEH+TDEL}
DE frame width	T _{DE}	-	480	-	T _{DEH+TDEL}

Note We suggest using the typical value, so it can have better performance.

6.2 Timing Controller Timing Chart

Clock and Data input waveforms

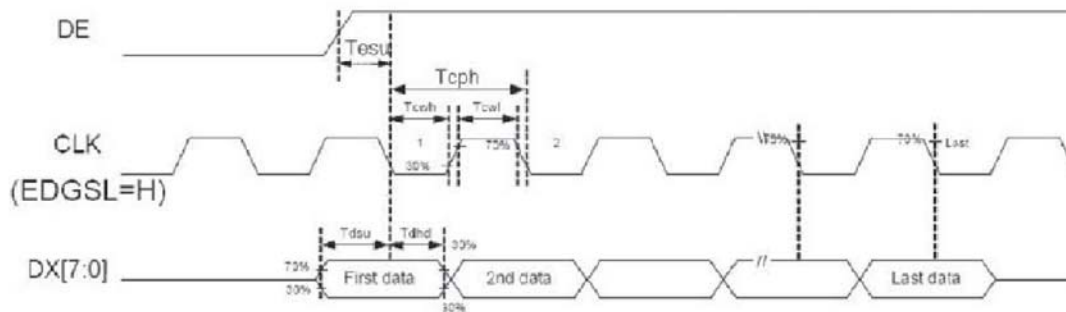

6.3 Data input format

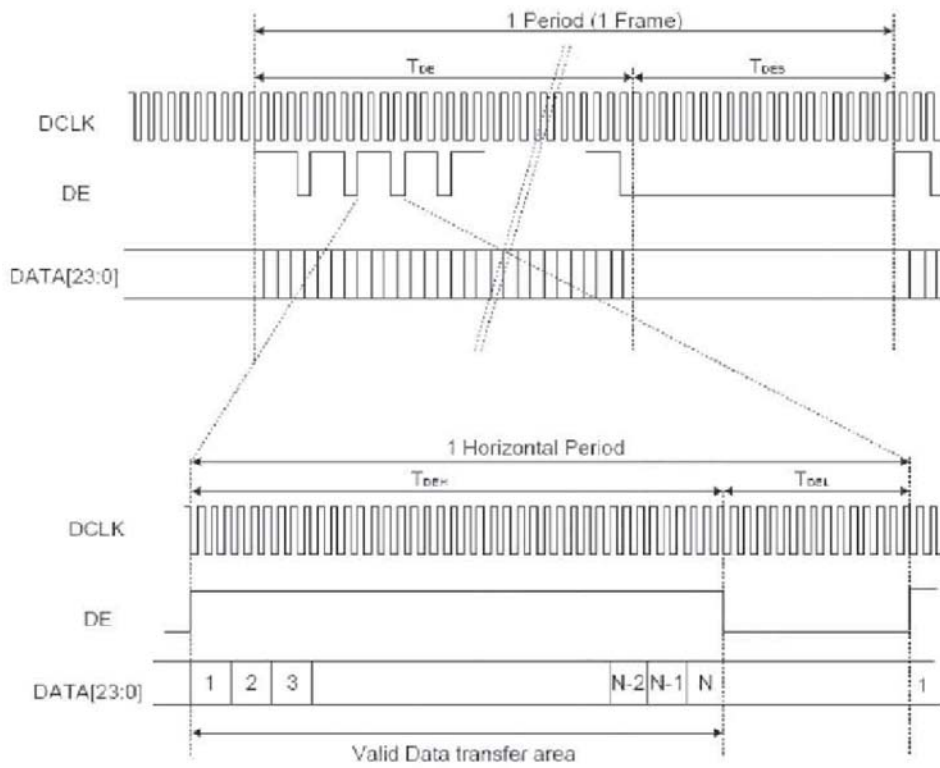

6.4 Power ON/OFF sequence

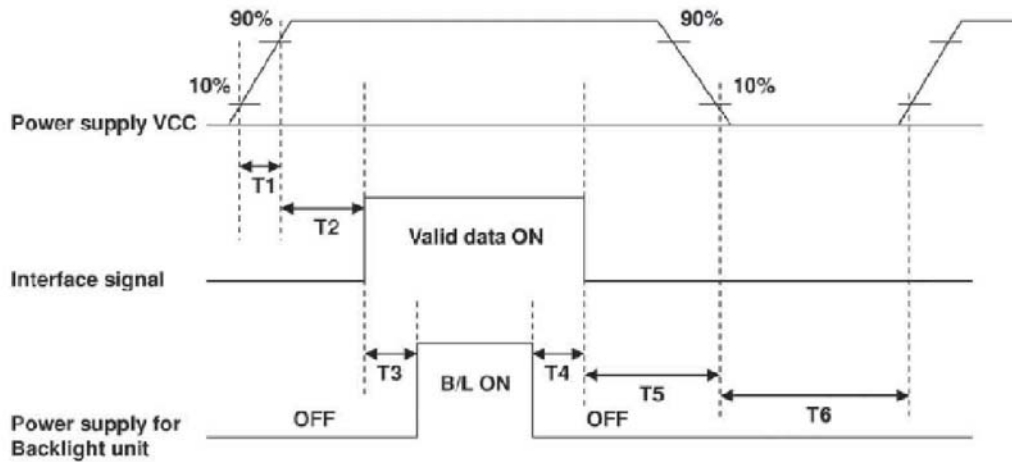

Parameter	SPEC.			Unit
	Min.	Typ.	Max.	
T1	1		2	ms
T2	0	60		ms
T3	200			ms
T4	200			ms
T5	1			ms
T6	1000			ms

7. OPTICAL CHARACTERISTIC

Item	Symbol	Condition	Min.	Typ.	Max.	Unit	Remark
Brightness	-	Viewing normal angle $\theta = \phi = 0$	-	280	-	cd/m ²	Center of display
Response time	Tr		-	5	10	ms	Note 3, 5
	Tf		-	11	16	ms	
Contrast ratio	CR			250	400	-	-
Color Chromaticity	White	Wx	0.249	0.299	0.349	-	Note 2, 6, 7
		Wy	0.278	0.328	0.378		
Viewing angle	Hor	θR	60	70	-	Deg.	Note 1
		θL	60	70	-		
	Ver	ϕI	50	60	-		
		ϕB	60	70	-		

HANTRONIX, INC.
10080 BUBB RD.
CUPERTINO, CA 95014

Q.A.:
Z.W.

REV.:
1.0

HDA700LT-2S

SHEET 6 OF 13

DATE:
5/18/12

Note 1: Definition of viewing angle range

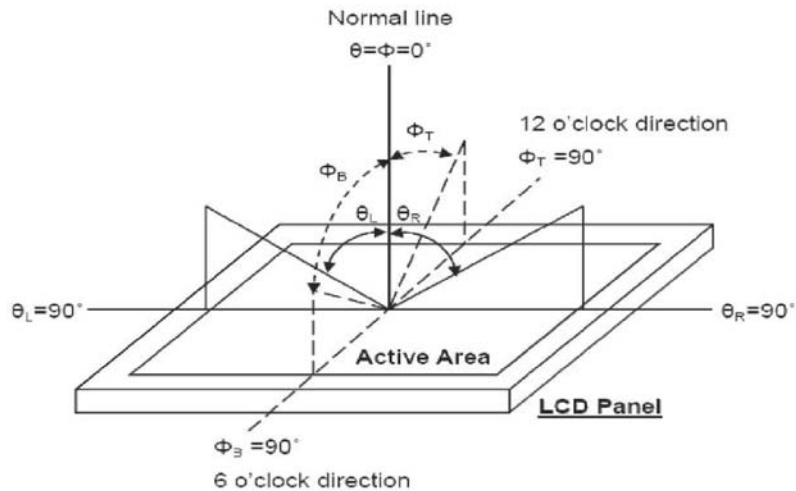

Fig. 7-1 Definition of viewing angle

Note 2: Test equipment setup:

After stabilizing and leaving the panel alone at a driven temperature for 10 minutes, the measurement should be executed. Measurement should be executed in a stable, windless, and dark room. Optical specifications are measured by Topcon BM-7 luminance meter 1.0° field of view at a distance of 50cm and normal direction.

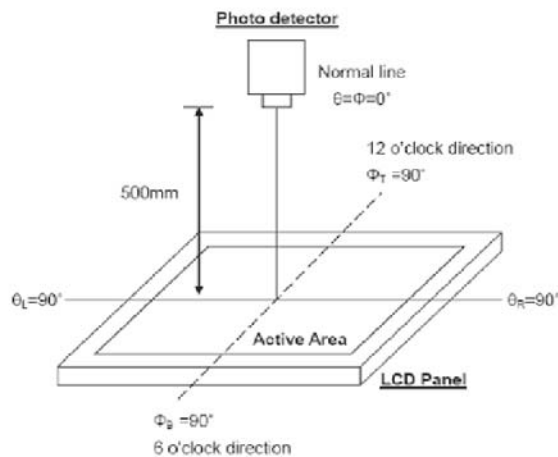

Fig.7-2 Optical measurement system setup

Note 3: Definition of Response time:

The response time is defined as the LCD optical switching time interval between "White state and "Black" state.

Rise time, T_r , is the time between photo detector output intensity changed from 90% to 10%. And fall time, T_f , is the

HANTRONIX, INC. 10080 BUBB RD. CUPERTINO, CA 95014	Q.A.:	REV.:	HDA700LT-2S	SHEET 7 OF 13
	Z.W.	1.0		DATE: 5/18/12

time between photo detector output Intensity changed from 10% to 90%

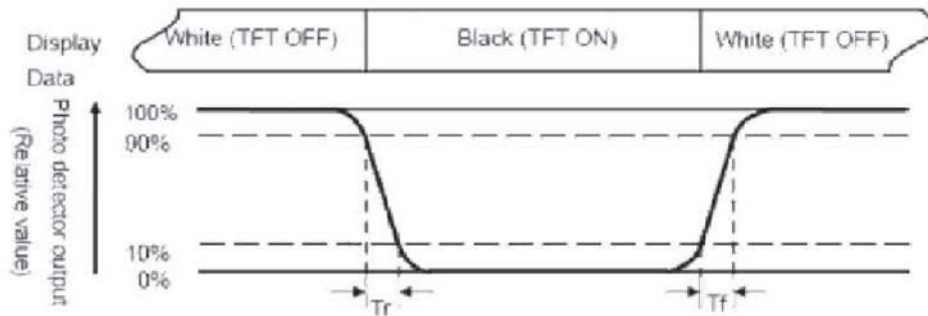

Fig. 7-3 Definition of response time

Note 4: Definition of contrast ratio:

The contrast ratio is defined as the following expression.

Contrast ratio (CR)=

$$\frac{\text{Luminance measured when LCD on the "White" state}}{\text{Luminance measured when LCD on the "Black" state}}$$

Note 5: White $V_i = V_{i50} \pm 1.5V$

Black $V_i = V_{i50} \pm 2.0V$

"±" means that the analog input signal swings in phase with VCOM signal.

"±" means that the analog input signal swings out of phase with VCOM signal.

The 100% transmission is defined as the transmission of LCD panel when all the input terminals of module are electrically opened.

Note 6: Definition of color chromaticity (CIE 1931)

Color coordinates measured at the center point of LCD

Note 7: Measured at the center area of the panel when all the input terminals of LCD panel are electrically opened.

Note 8 : Uniformity (U) = $\frac{\text{Brightness (min)}}{\text{Brightness (max)}} \times 100\%$ Brightness (max)

HANTRONIX, INC. 10080 BUBB RD. CUPERTINO, CA 95014	Q.A.:	REV.:	HDA700LT-2S	SHEET 8 OF 13
	Z.W.	1.0		DATE: 5/18/12

8. INTERFACE

8.1 LCM PIN Definition

Pin No.	Symbol	Description	Remark
1	GND	Power Ground	
2	GND	Power Ground	
3	NC	Not Connect	
4	Vcc	Power Supply for Digital Circuit	
5	Vcc	Power Supply for Digital Circuit	
6	Vcc	Power Supply for Digital Circuit	
7	Vcc	Power Supply for Digital Circuit	
8	NC	Not Connect	
9	DE	Data Enable	
10	GND	Power Ground	
11	GND	Power Ground	
12	GND	Power Ground	
13	B5	Blue Data 5 (MSB)	
14	B4	Blue Data 4	
15	B3	Blue Data 3	
16	GND	Power Ground	
17	B2	Blue Data 2	
18	B1	Blue Data 1	
19	B0	Blue Data 0 (LSB)	
20	GND	Power Ground	
21	G5	Green Data 5 (MSB)	
22	G4	Green Data 4	
23	G3	Green Data 3	
24	GND	Power Ground	
25	G2	Green Data 2	
26	G1	Green Data 1	
27	G0	Green Data 0 (LSB)	
28	GND	Power Ground	
29	R5	Red Data 5 (MSB)	
30	R4	Red Data 4	
31	R3	Red Data 3	
32	GND	Power Ground	
33	R2	Red Data 2	
34	R1	Red Data 1	
35	R0	Red Data 0 (LSB)	
36	GND	Power Ground	
37	GND	Power Ground	
38	DCLK	Clock Signals ; Latch Data at the Falling Edge	
39	GND	Power Ground	
40	GND	Power Ground	

HANTRONIX, INC.
10080 BUBB RD.
CUPERTINO, CA 95014

Q.A.:
Z.W.

REV.:
1.0

HDA700LT-2S

SHEET 9 OF 13

DATE:
5/18/12

T/P

Pin No.	Symbol	Description	Remark
1	LEFT	The pin of the touch panel	
2	BOTTOM	The pin of the touch panel	
3	RIGHT	The pin of the touch panel	
4	UPPER	The pin of the touch panel	

8.2 Backlight Driving Part

Pin No.	Symbol	Description
1	VLEDA	Red. LED Anode
2	VLEDK	White, LED Cathode

9. BLOCK DIAGRAM

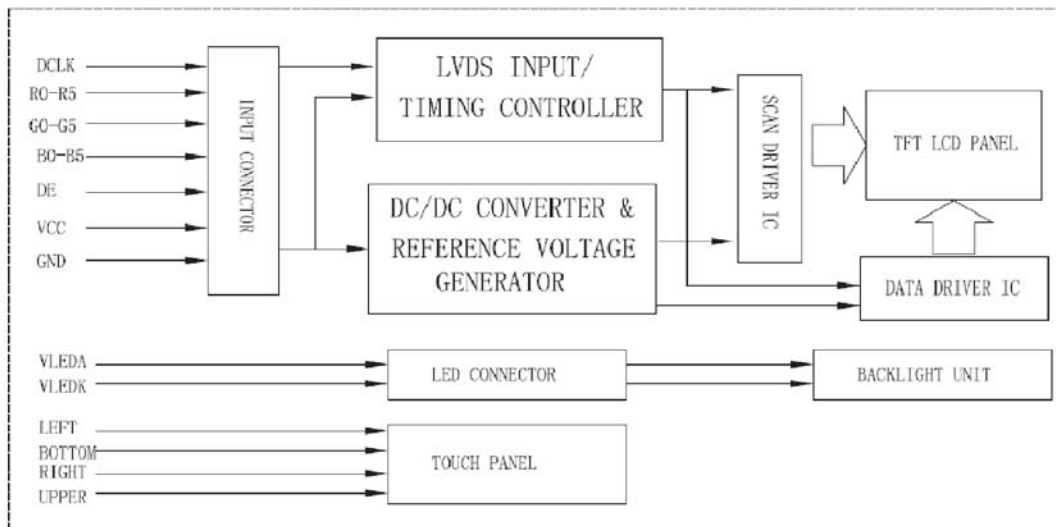

10. QUALITY ASSURANCE

No.	Test Items	Test Condition
1	High Temperature Storage Test	Ta=80°C Dry 240h
2	LOW Temperature Storage Test	Ta=-30°C Dry 240h
3	High Temperature Operation Test	Ta=70°C Dry 240h
4	LOW Temperature Operation Test	Ta=-20°C Dry 240h
5	High Temperature and High Humidity Operation Test	Ta=60°C 90%RH 240h
6	Electro Static Discharge Test	150pF,330Ω,±8KV(Contact)/±15KV(Air),5points/panel, 5 times/point
7	Shock Test(non-operating)	Half sine wave,180G,2ms one shock of each six faces I.e.run 180G 2ms for all six faces
8	Vibration Test(non-operating)	Sine wave,10~500~10Hz 1.5G,0.37oct/min 3axis,1hour/axis
9	Thermat Shock Test	-20°C(0.5h)~70°C(0.5h)/100 cycles(Dry)

****Ta=Ambient Temperature

HANTRONIX, INC. 10080 BUBB RD. CUPERTINO, CA 95014	Q.A.:	REV.:	HDA700LT-2S	SHEET 11 OF 13
	Z.W.	1.0		DATE: 5/18/12

12. TOUCH PANEL RAWING

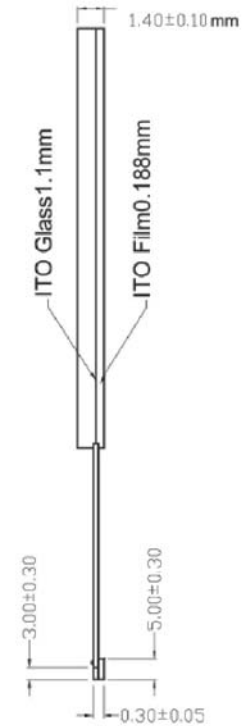
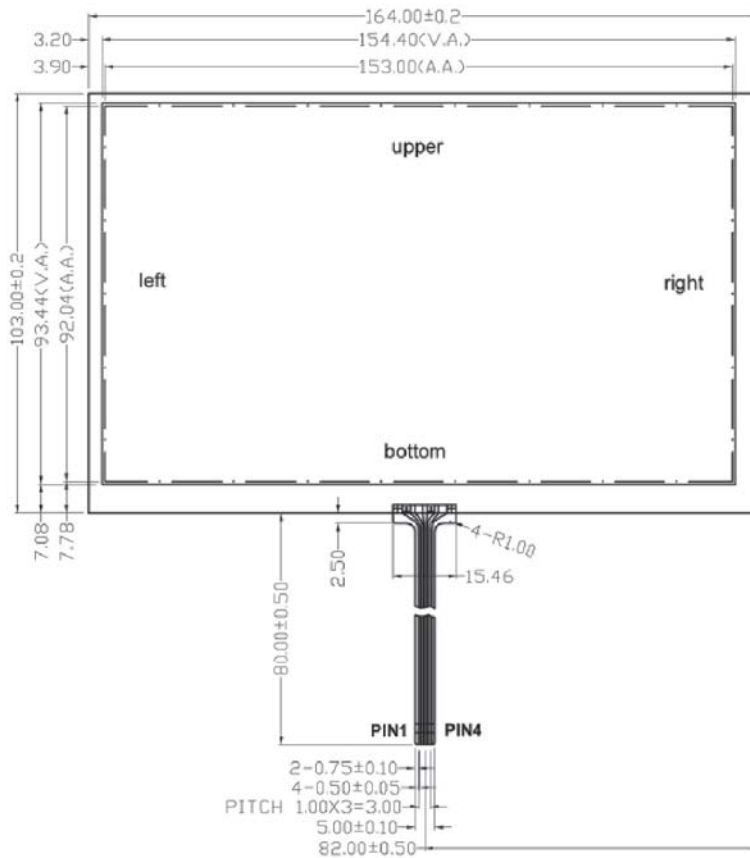

NOTE:

1. Driving condition: DC5V;
2. Operation force: 60~100g;
3. Linearity $\leq \pm 1.5\%$; Insulation resistance $> 10M \Omega$, 25V(DC);
4. Operating environment: $-20^{\circ}\text{C} \sim +70^{\circ}\text{C}$, $\leq 80\% \text{RH}$;
5. Storage environment: $-30^{\circ}\text{C} \sim +80^{\circ}\text{C}$, $< 80\% \text{RH}$;
6. Light transparency: $> 75\%$;
7. Structure type: ITO Film/ITO Glass(F/G);
8. Connector type: FPC connect;
9. ITO Film type: Anti-glare hard coating and anti-newton ring ;
10. Tapping durability: 1,000,000 times;
11. Bound time: $< 10\text{ms}$;
12. Compliant ROHS.

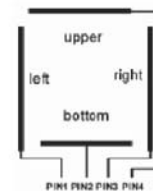

HANTRONIX, INC.
10080 BUBB RD.
CUPERTINO, CA 95014

Q.A.:
Z.W.

REV.:
1.0

HDA700LT-2S

SHEET 12 OF 13

DATE:
5/18/12



Компания «ЭлектроПласт» предлагает заключение долгосрочных отношений при поставках импортных электронных компонентов на взаимовыгодных условиях!

Наши преимущества:

- Оперативные поставки широкого спектра электронных компонентов отечественного и импортного производства напрямую от производителей и с крупнейших мировых складов;
- Поставка более 17-ти миллионов наименований электронных компонентов;
- Поставка сложных, дефицитных, либо снятых с производства позиций;
- Оперативные сроки поставки под заказ (от 5 рабочих дней);
- Экспресс доставка в любую точку России;
- Техническая поддержка проекта, помощь в подборе аналогов, поставка прототипов;
- Система менеджмента качества сертифицирована по Международному стандарту ISO 9001;
- Лицензия ФСБ на осуществление работ с использованием сведений, составляющих государственную тайну;
- Поставка специализированных компонентов (Xilinx, Altera, Analog Devices, Intersil, Interpoint, Microsemi, Aeroflex, Peregrine, Syfer, Eurofarad, Texas Instrument, Miteq, Cobham, E2V, MA-COM, Hittite, Mini-Circuits, General Dynamics и др.);

Помимо этого, одним из направлений компании «ЭлектроПласт» является направление «Источники питания». Мы предлагаем Вам помощь Конструкторского отдела:

- Подбор оптимального решения, техническое обоснование при выборе компонента;
- Подбор аналогов;
- Консультации по применению компонента;
- Поставка образцов и прототипов;
- Техническая поддержка проекта;
- Защита от снятия компонента с производства.



Как с нами связаться

Телефон: 8 (812) 309 58 32 (многоканальный)

Факс: 8 (812) 320-02-42

Электронная почта: org@eplast1.ru

Адрес: 198099, г. Санкт-Петербург, ул. Калинина, дом 2, корпус 4, литера А.