

## 'S1D13717 Mobile Graphics Engine

February 2012

The S1D13717 is an Mobile Graphics Engine solution designed with support for the digital video revolution in mobile products. The S1D13717 contains an integrated camera interface, hardware JPEG encoder/decoder and SD Memory Card interface. Seamlessly connecting to both direct and indirect CPU interfaces, it provides support for up to two LCD panels. The Mobile Graphics Engine supports all standard TFT panel types, eliminating the need for an external timing control IC. The S1D13717, with it's 224K bytes of embedded SRAM and rich feature set, provides a low cost, low power, single chip solution to meet the demands of embedded markets requiring Digital Video, such as Mobile Communications devices and Palm-size PDAs.

Additionally, products requiring a rotated display can take advantage of the SwivelView™ feature which provides hardware rotation of the display memory transparent to the software application. The S1D13717 also provides support for "Picture-in-Picture Plus" (a variable size window with overlay functions). Higher performance is provided by the Hardware Acceleration Engine which provides 2D BitBLT functions.

The S1D13717 provides impressive support for cellular and other mobile solutions requiring Digital Video support. However, its impartiality to CPU type or operating system makes it an ideal display solution for a wide variety of applications.

### ■ FEATURES

- Embedded 224K byte SRAM Display Buffer
- Low Operating Voltage
- Direct and Indirect CPU interfaces
- Programmable resolutions and color depths
- Support for 2 panels (LCD2 must be RAM integrated)
- Support for RGB, Serial and Parallel I/F Panels
- Internal PLL or digital clock input
- SD Memory Card interface
- Single port Camera interface w/resize function
- Hardware JPEG encoder/decoder
- YUV to RGB converter
- SwivelView™ (90°, 180°, 270° hardware rotation of displayed image)
  - (Patent # 5,734,875 - Patent # 5,956,049 - Patent #6,262,751)
- "Picture-in-Picture Plus"
- 2D Hardware Acceleration Engine
- Software Initiated Power Save Mode



### ■ SYSTEM BLOCK DIAGRAM

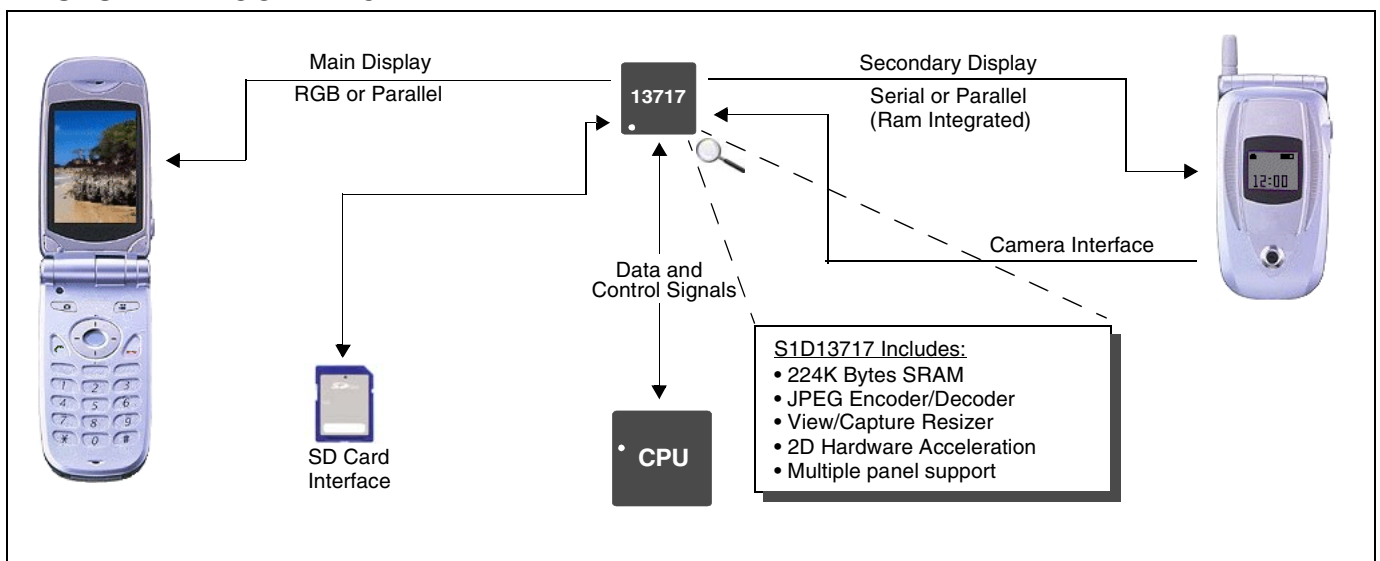

## S1D13717

### DESCRIPTION

#### Integrated Display Buffer

- 224K bytes of embedded SRAM
- Addressable as a single linear address space

#### CPU Interface

- 16-bit Generic Asynchronous CPU interface
- Direct and Indirect addressing

#### Panel Support

- Supports up to 2 LCD panels
- LCD1: 9/12/18-bit RGB panel  
LCD2: 8/9-bit Serial Ram Integrated panel
- LCD1: 8/16/18-bit Parallel Ram Integrated panel  
LCD2: 8/9-bit Serial Ram Integrated panel
- LCD1: 8/16/18-bit Parallel Ram Integrated panel  
LCD2: 8/16/18-bit Parallel Ram Integrated panel
- LCD1: 9/12/18-bit RGB panel  
LCD2: 8-bit Parallel Ram Integrated panel
- TFT, ND-TFD, and Extended TFT
- Typical resolution of:  
up to 220x176 at 32bpp  
up to 320x240 at 16 bpp

#### Acceleration

- 2D BitBLT Engine
- SwivelView™: 90°, 180°, 270° hardware rotation of displayed image
- Mirror Display: hardware “mirror” image of display

#### Display Features

- 8/16/32 bit-per-pixel (bpp) support
- Picture-in-Picture Plus: displays a variable size window overlaid over the background image
- Overlay Functions
- Pixel Doubling: doubles the effective resolution
- Video Invert: inverts display data

#### Digital Video

- Single port Camera Interface (YUV 4:2:2)
- Hardware JPEG Encoder (YUV 4:2:2, 4:1:1, 4:2:0)
- Hardware JPEG Decoder (YUV 4:4:4, 4:2:2, 4:1:1, 4:2:0)
- YUV Display/Capture (YUV 4:2:2, 4:2:0)
- Memory Image JPEG Encode (YUV 4:2:2, 4:1:1, 4:2:0)
- View and Capture hardware resizer with trimming and reduction functions
- YUV to RGB and RGB to YUV converters
- Support for external MPEG codec interface

#### Miscellaneous

- Internal PLL or digital clock input
- Software initiated power save mode
- Multiple General Purpose IO pins
- CORE<sub>VDD</sub> 1.8 volts and IO<sub>VDD</sub> 3.0 volts
- S1D13717B00B - PFBGA12-180-pin package
- S1D13717F00A - QFP21-176-pin package

### CONTACT YOUR SALES REPRESENTATIVE FOR THESE COMPREHENSIVE DESIGN TOOLS

- S1D13717 Technical Documentation
- S1D13717 Evaluation Boards
- CPU Independent Software Utilities
- Royalty Free source level driver code



**symbian**  
OS



**Japan**  
Seiko Epson Corporation  
IC International Sales Group  
421-8, Hino, Hino-shi  
Tokyo 191-8501, Japan  
Tel: 042-587-5812  
Fax: 042-587-5564  
<http://www.epson.co.jp/>

**Hong Kong**  
Epson Hong Kong Ltd.  
20/F, Harbour Centre  
25 Harbour Road  
Wanchai, Hong Kong  
Tel: 2585-4600  
Fax: 2827-4346  
<http://www.epson.com.hk/>

**North America**  
Epson Electronics America, Inc.  
214 Devon Drive  
San Jose, CA 95112, USA  
Tel: (800) 228-3964  
Fax: (408) 922-0238  
<http://www.eea.epson.com/>

**Europe**  
Epson Europe Electronics GmbH  
Riesstrasse 15  
80992 Munich, Germany  
Tel: 089-14005-0  
Fax: 089-14005-110  
<http://www.epson-electronics.de/>

**Taiwan**  
Epson Taiwan Technology & Trading Ltd.  
14F, No. 7  
Song Ren Road  
Taipei 110  
Tel: 02-8786-6688  
Fax: 02-8786-6677  
<http://www.epson.com.tw/>

**Singapore**  
Epson Singapore Pte Ltd  
1 HarbourFront Place #03-02  
HarbourFront Tower One  
Singapore, 098633  
Tel: (65) 6586-5500  
Fax: (65) 6271-3182  
<http://www.epson.com.sg/>

© SEIKO EPSON CORPORATION 2004-2012. All rights reserved.

Information in this document is subject to change without notice. You may download and use this document, but only for your own use in evaluating Seiko Epson/EPSON products. You may not modify the document. Epson Research and Development, Inc. disclaims any representation that the contents of this document are accurate or current. The Programs/Technologies described in this document may contain material protected under U.S. and/or International Patent laws.

EPSON is a registered trademark of Seiko Epson Corporation. All other trademarks are the property of their respective owners.



Компания «ЭлектроПласт» предлагает заключение долгосрочных отношений при поставках импортных электронных компонентов на взаимовыгодных условиях!

Наши преимущества:

- Оперативные поставки широкого спектра электронных компонентов отечественного и импортного производства напрямую от производителей и с крупнейших мировых складов;
- Поставка более 17-ти миллионов наименований электронных компонентов;
- Поставка сложных, дефицитных, либо снятых с производства позиций;
- Оперативные сроки поставки под заказ (от 5 рабочих дней);
- Экспресс доставка в любую точку России;
- Техническая поддержка проекта, помощь в подборе аналогов, поставка прототипов;
- Система менеджмента качества сертифицирована по Международному стандарту ISO 9001;
- Лицензия ФСБ на осуществление работ с использованием сведений, составляющих государственную тайну;
- Поставка специализированных компонентов (Xilinx, Altera, Analog Devices, Intersil, Interpoint, Microsemi, Aeroflex, Peregrine, Syfer, Eurofarad, Texas Instrument, Miteq, Cobham, E2V, MA-COM, Hittite, Mini-Circuits, General Dynamics и др.);

Помимо этого, одним из направлений компании «ЭлектроПласт» является направление «Источники питания». Мы предлагаем Вам помощь Конструкторского отдела:

- Подбор оптимального решения, техническое обоснование при выборе компонента;
- Подбор аналогов;
- Консультации по применению компонента;
- Поставка образцов и прототипов;
- Техническая поддержка проекта;
- Защита от снятия компонента с производства.



#### Как с нами связаться

**Телефон:** 8 (812) 309 58 32 (многоканальный)

**Факс:** 8 (812) 320-02-42

**Электронная почта:** [org@eplast1.ru](mailto:org@eplast1.ru)

**Адрес:** 198099, г. Санкт-Петербург, ул. Калинина, дом 2, корпус 4, литера А.