



ANALOG

FxLED, BACKLIGHT, SENSOR SELECTOR GUIDE 2015



FxLED | BACKLIGHT | SENSOR

FxLED Selector

- Audio Modulate
- Shift Register
- Gamma Correction
- Auto Breath
- Charge Pump
- Eval Board

FxLED Driver

<p>IS31FL3199 9 Outputs 3 - RGB, 16M color QFN-20</p> <p>IS31FL3196 6 Outputs 2 - RGB, 16M color QFN-20</p> <p>IS31FL3193/3193C 3 Outputs 1-RGB DFN-10(FL3193) WCSP-8(FL3193C)</p> <p>IS31FL3191 1 Output Single LED UTQFN-9</p>	<p>IS31FL3726 16-Channel LED, 60mA QFN-24, TSSOP-24</p> <p>IS31FL3236 36-Channel LED QFN-44, TQFP-48</p> <p>IS31FL3235 28-Channel LED QFN-36</p> <p>IS31FL3218 18-Channel LED QFN-24, SOP-24</p> <p>IS31FL3216 16-Channel LED QFN-28</p>	<p>IS31FL3732 144 LED Driver Cascade for synchronization QFN-40</p> <p>IS31FL3731/3731C 144 LED Driver QFN-28, SSOP-28</p> <p>IS31FL3730 128 LED Driver QFN-24</p> <p>IS31FL3728 64 LED Driver (8x8) Audio Freq Equalizer QFN-24</p>
--	---	--

RGB

Multi-Channel

Matrix

Backlight Selector

- Boost Converter
- Charge Pump
- DC Level Dim
- Eval Board
- Linear
- Pulse Count Dim
- PWM Dim

Backlight LED Driver

<p>IS31BL3233A (boost) 750mAx2 Flash Time out function DFN-14</p> <p>IS31BL3231/3232 750mA/1.2A Flash Time out function (BL3232) DFN-10</p>	<p>IS31BL3212 23 mA Output DFN-8</p> <p>IS31BL3228A/B 20 mA Output UTQFN-12</p>	<p>IS31BL3230 40 mA or 320mA ParallelQFN-16</p> <p>IS31BL3229 20 mA Output QFN-20</p>	<p>IS31BL3508A/B 1.5 Amp Integrated FET 10 LEDs TSOT-23-6, SOT23-6</p> <p>IS31BL3506A 2.2 Amp Integrated FET 9 or 8 LEDs DFN-8, TSOT-23-6</p>	<p>IS32BL3552 2 channel @ 360mA 1.5% accuracy</p> <p>IS32BL3554 4 channel @ 180mA 1.5% accuracy</p> <p>IS32BL3556 4 channel @ 100mA Integrated Power MOS</p>
---	---	---	---	---

1~2

4

8

10

Automotive

Number of LEDs

Sensor Selector

- Eval Board

Sensor

<p>IS31SE5000 Gesture Sensor/Proximity 2 receiver, 1 transmit UTQFN-12</p> <p>IS31SE5001 Proximity Sensor 1 receiver, 1 transmit QFN-8</p>	<p>IS31SE5100 8 Touch input/LED output QFN-24, SSOP-24</p> <p>IS31SE5104 4 Touch input/LED output SOP-16, QFN-16</p>
--	--

IR

Capacitance

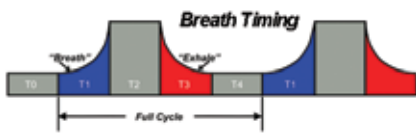
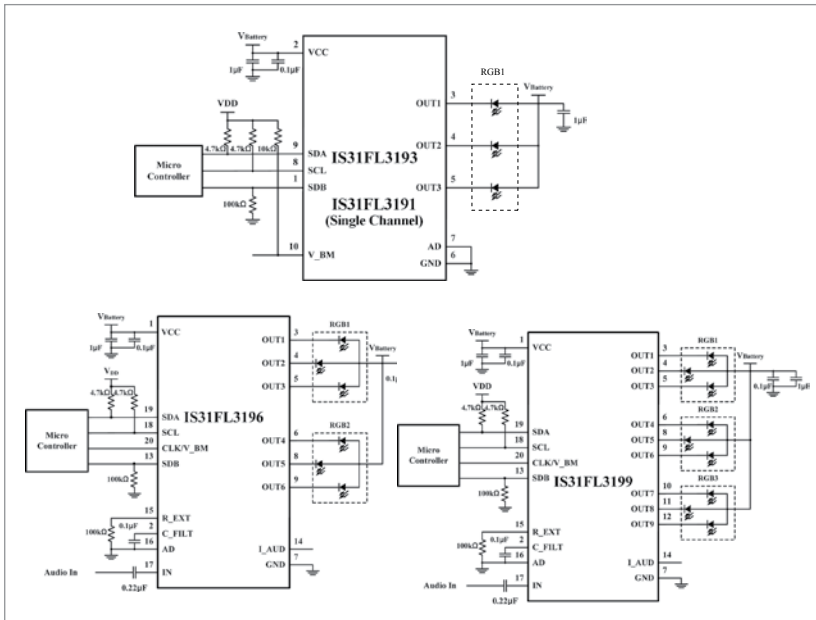

Example of "Breath Timing"
Period = T1 : T4

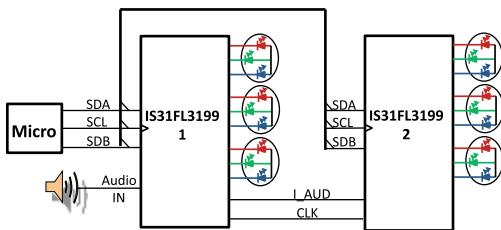

Multi Device Connect

Part No.	No. RGB Group	LED Current Levels	Cascade	Audio Input	Package	Package Outline
IS31FL3191	0	5	No	No	UTQFN-9	
IS31FL3193	1	5	No	No	DFN-10	
IS31FL3193C	1	5	No	No	WLCSP-8	
IS31FL3196	2	8	Yes	Yes	QFN-20	
IS31FL3199	3	8	Yes	Yes	QFN-20	

IS31FL3193, IS31FL3196, IS31FL3199

- 1, 2 and 3 RGB Support

Features

- Supply voltage 2.7V to 5.5V
- Audio modulation with AGC
- I2C interface, automatic address increment function
- RGB groups, up to 16 million color LED breathing system-free pre-established pattern
- Independently controlled automatic and semiautomatic breathing system-free pre-established pattern
- Independently controlled outputs of 256 PWM steps
- Programmable output current levels
- Cascade for the synchronization of chips
- Over-temperature protection
- 31FL3193C - In a WLCSP-8 [1.5x1.0] package

Applications

- Mobile phones and other hand-held devices for LED display
- LED in White Good Appliances

Description

Multi-channel light effect LED drivers with two-dimensional auto breathing mode and an audio modulated display mode. They have a One Shot Programming mode and PWM Control mode for RGB lighting effects. The maximum output current can be adjusted in set levels [5mA~40mA].

The devices include an audio modulated display mode, wherein the brightness of LED can be modulated by an audio analog signal. There is a cascade pin for the synchronization of two chips.

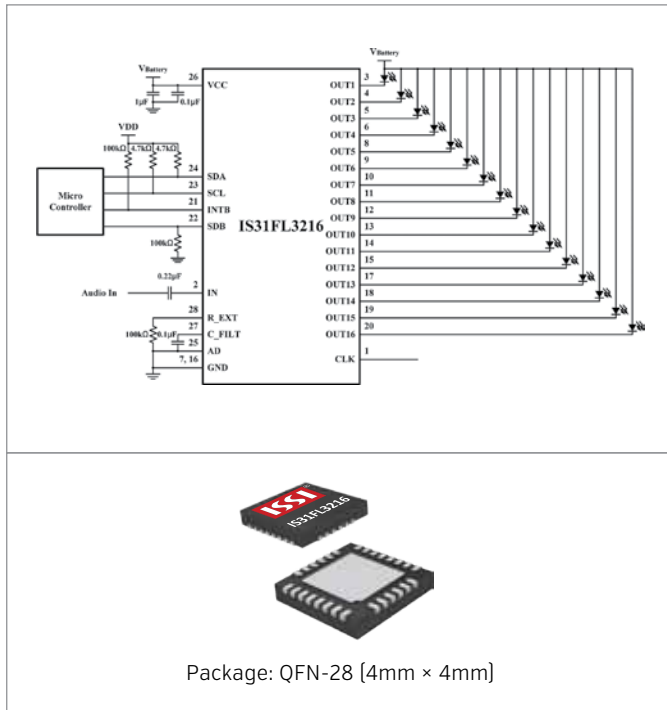

IS31FL3216 - 16 Channel

Features

- 2.7V to 5.5V supply
- I2C interface, automatic address increment function
- Individually modulate each LED brightness with 256 steps PWM
- Audio Frame Mode with 8 frames of memory for animations
- 8 of 16 outputs not used as LED drivers can be used as GPIO ports
- Over-temperature protection



Applications

- Mobile phones and other hand-held devices for LED display
- LED in White Good Appliances

Description

The IS31FL3216 is a fun light LED controller with an audio modulation mode. It can store data of 8 frames with internal RAM to play small animations automatically. It can sample an input analog signal to modulate the intensity of LEDs, or control 8 frames playing by internal ADC block. The LED current of each channel can be set in 256 steps by adjusting the PWM duty cycle through an I2C interface. 8 channels can be used as GPIO ports.



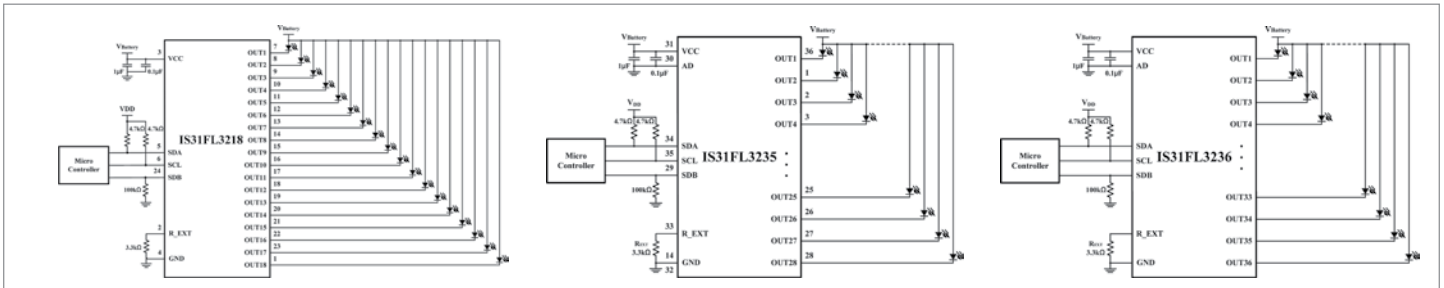

IS31FL3218, IS31FL3235, IS31FL3236
-18, 28 and 36 LED channel

Features

- 2.7V to 5.5V supply
- I2C interface, automatic address increment function
- Internal reset register
- Modulate LED brightness with 256 steps PWM
- Each channel can be controlled independently
- Each channel can be scaled independently by 1, 1/2, 1/3 and 1/4

Applications

- Mobile phones and other hand-held devices for LED display
- LED in White Good Appliances

Description

IS31FL3218, IS31FL3235, IS31FL3236 are constant current multi-channel LED controllers with independent PWM control. The output current of each channel can be set at up to 38mA [Max.] by an external resistor and independently scaled by a factor of 1, 1/2, 1/3 and 1/4. The average LED current of each channel can be changed in 256 steps by changing the PWM duty cycle through an I2C interface.

They can be turned off by pulling the SDB pin low or by using the software shutdown feature to reduce power consumption.

Part No.	No. of Channels	Current Scaling	Package	Package Outline
IS31FL3218	18	No	QFN-24 SOP-24	
IS31FL3235	28	Yes	QFN-36	
IS31FL3236	36	Yes	QFN-44 TQFP-48	

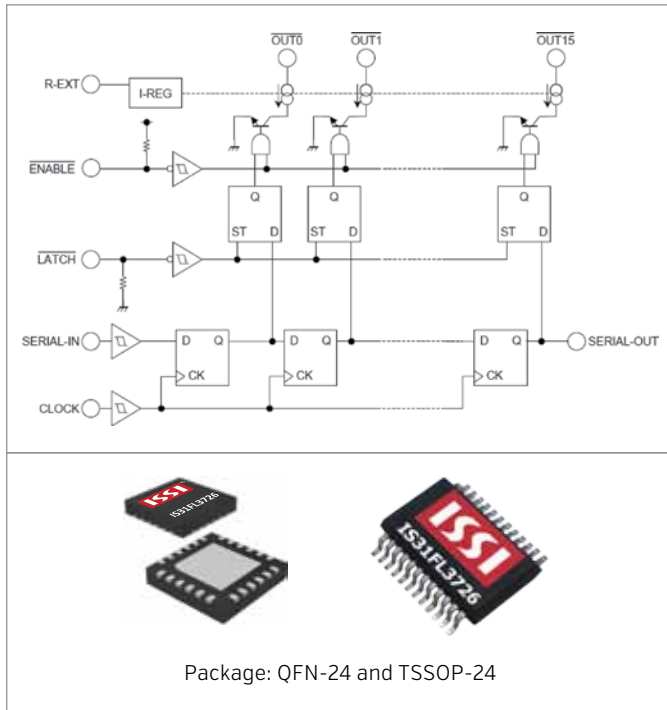

IS31FL3726 - 16-Bit Serial Shift LED Driver w/ PWM control

Features

- Output current capability and number of outputs: 60mA × 16 outputs
- Constant current range: 5mA to 60mA
- Application output voltage: ≥0.4V
- For anode-common LEDs
- Power supply voltage range, $V_{DD} = 3.3V$ to 5.5V
- Serial and parallel data transfer rate: 20MHz (Max. cascade connection)

Applications

- Cellular phones
- MP3/MP4/CD/mini disk players
- Toys

Description

The IS31FL3726 is comprised of constant current drivers designed for color LEDs. The output current value can be adjusted from 5mA to 60mA through the external resistor. As a result, all outputs will have virtually the same current levels.

This driver incorporates 16-bit constant current outputs, a 16-bit shift register, a 16-bit latch and a 16-bit AND-gate circuit.

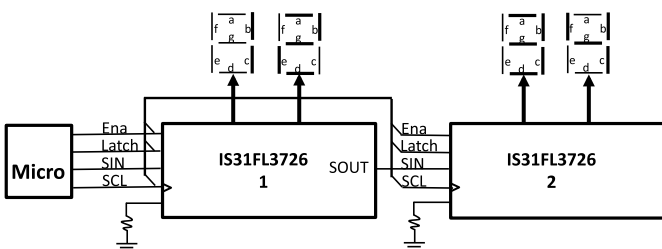

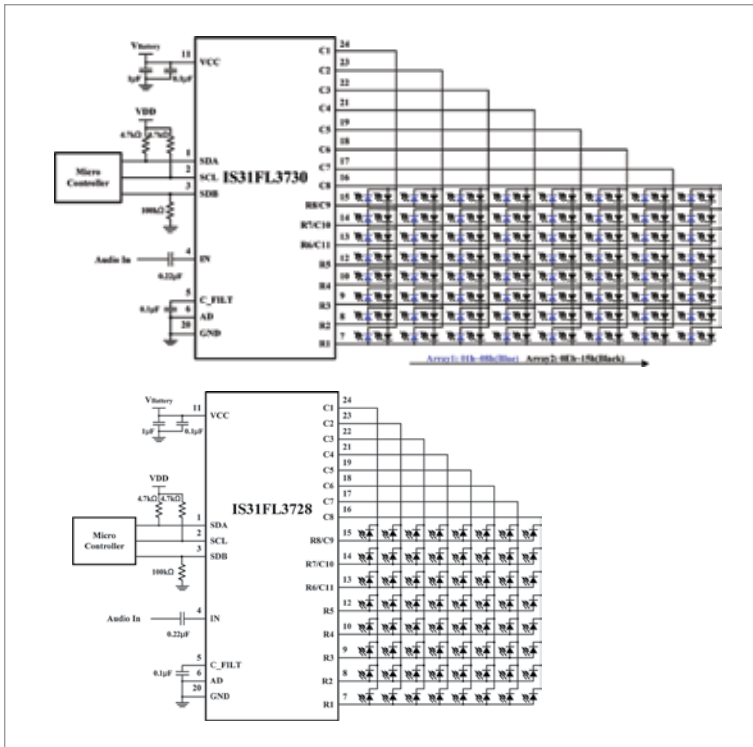

IS31FL3730, IS31FL3728 -
Audio Modulated Matrix LED Drivers

Features

- Supply voltage range: 2.7V to 5.5V
- 400kHz I2C-compatible interface
- One address pin with 4 logic levels to allow four I2C slave addresses
- Individual blink control
- Auto intensity breathing during the switching of different frames
- Audio modulated LED display frame intensity
- 8 frames memory for animations
- Picture mode and animation mode





Applications

- Mobile phones and other hand-held devices for LED display
- LED in White Good Appliances
- Audio frequency equalizer display

Description

The devices are compact LED driver for addressing multiple LEDs in a matrix arrangement which are programmable via an I2C interface. Additionally each of the LEDs can be dimmed individually with 8-bit allowing 256 steps of linear dimming. The intensity of any matrix picture can be modulated by an audio signal. Additional features help minimize MCU/DSP software overhead.

Part No.	Matrix Size	Current Scaling	Package	Package Outline
IS31FL3728	64 1 Block [64]	No	QFN-24	
IS31FL3730	128 2 Blocks [64]	Yes	QFN-24	

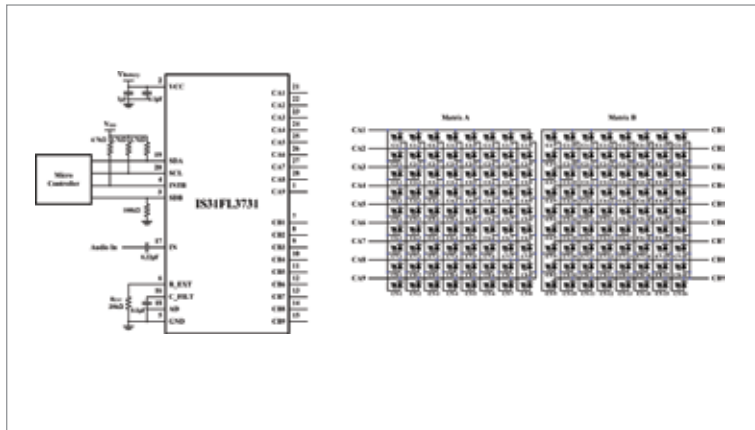

IS31FL3731/C - Support 144 LEDs

Features

- Supply voltage range: 2.7V to 5.5V
- 400kHz I2C-compatible interface
- Robust I2C bus signal levels (IS31LT3731C)
- 144 LEDs in dot matrix
- Individual blink control
- Individual PWM control 256 steps
- Individual on/off control
- Global current control 256 steps
- Cascade for synchronization of chips
- 8 frames memory for animations
- Picture mode and animation mode
- Auto intensity breathing during the switching of different frames
- LED frames displayed can be modulated with audio signal intensity
- LED light intensity can be modulated with audio signal intensity
- QFN-40 [5mm×5mm] package

Applications

- Mobile phones and other hand-held devices for LED display
- LED in home appliances
- Keyboard
- Bluetooth speaker system
- LED display

Part No.	Matrix Size	Current Scaling	Package	Package Outline
IS31FL3731/C	144 2 Blocks [72]	Yes	QFN-28 SSOP-28	

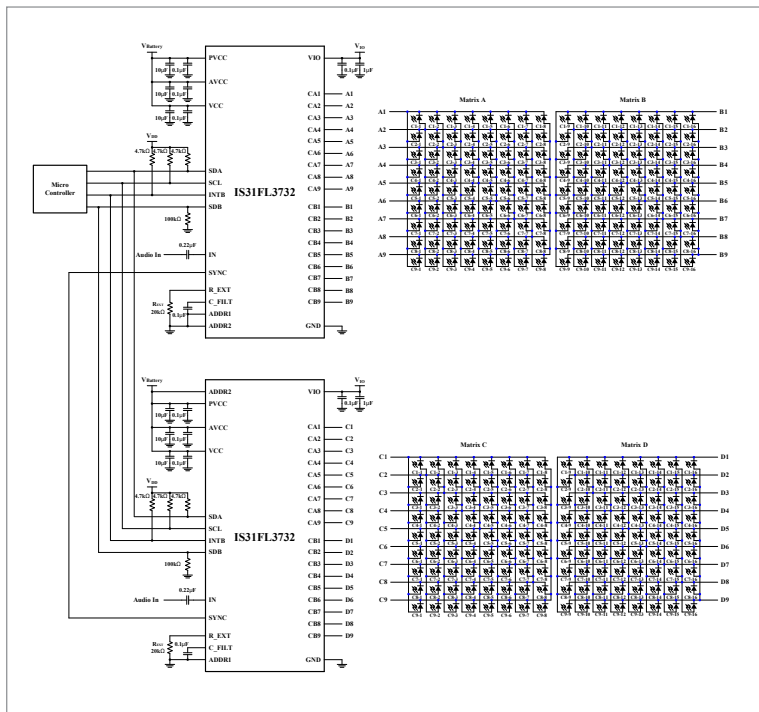

IS31FL3732 - 1MHz I2C Bus, Cascadable Features

- Supply voltage range: 2.7V to 5.5V
- 1MHz I2C-compatible interface
- Cascade for Synchronization
- 144 LEDs in dot matrix
- Individual blink control
- Individual PWM control 256 steps
- Individual on/off control
- Global current control 256 steps
- Cascade for synchronization of chips
- 8 frames memory for animations
- Picture mode and animation mode
- Auto intensity breathing during the switching of different frames
- LED frames displayed can be modulated with audio signal intensity
- LED light intensity can be modulated with audio signal intensity
- QFN-40 [5mm×5mm] package

Applications

- LED in home appliances
- Keyboard
- Bluetooth speaker system
- LED display

Part No.	Matrix Size	Current Scaling	Package	Package Outline
IS31FL3732	144 2 Blocks [72]	Yes	QFN-40	

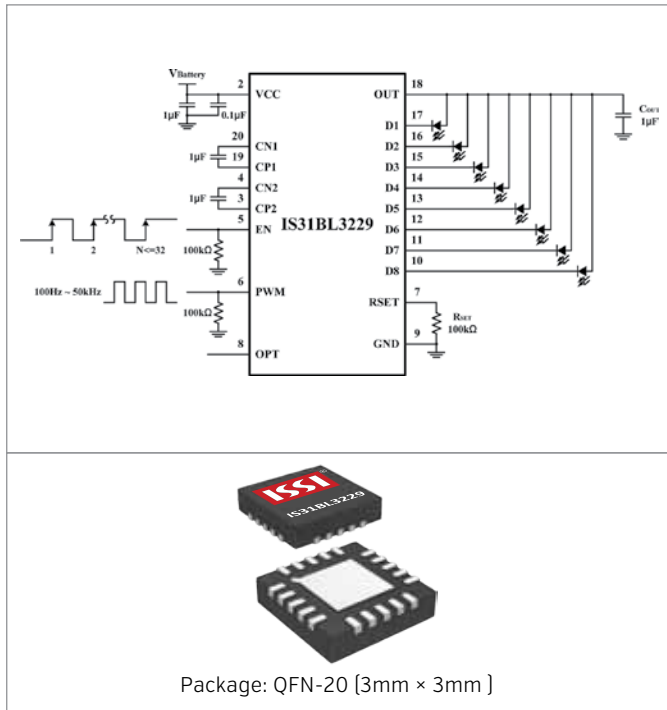

IS31BL3229 - 8 - LED Backlight Driver

Features

- Supply voltage: 2.7V ~ 5.5V
- 1X, 1.5X operating mode
- Fade in and fade out mode
- Output current can be 25mA
- 32 current level and PWM intensity control
- Low input current ripple, low EMI
- 90% high efficiency
- No inductors, low noise operation
- Over voltage protection on output
- Built-in thermal protection
- Automatic soft start
- Built-in thermal protection

Applications

- Cell phone, smart phone, PDA
- Mp3, Mp4, Personal Navigation Devices
- White LED backlighting

Description

The IS31BL3229 with a smart charge-pump circuit is a parallel white-LED driver with eight matched 20mA current outputs. It can supply a total output current of 160mA over an input voltage range of 2.7V to 5.5V.

The IS31BL3229 typically draws less than 1mA when placed in shutdown, and 0.7mA when operating in the no-load and 1X mode condition. If any of the outputs are not used, leave the pin(s) unconnected. Brightness can be controlled by simple-series-control techniques and external PWM signal.



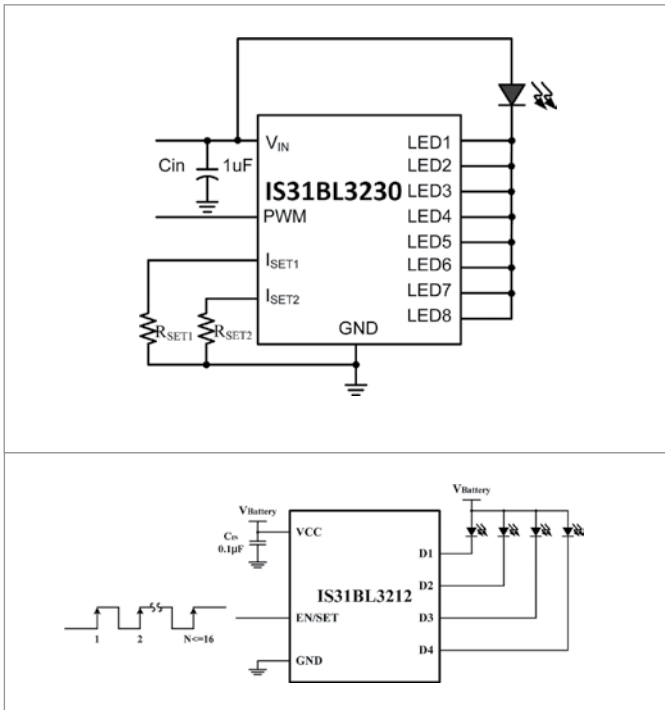

IS31BL3230, IS31BL3212 - Multichannel Linear Current Sink

Features

- Ultra low headroom voltage
- Cost effective LED driver
- Current adjustable via external resistors
- Best Noise and Efficiency Performance
- Highly integrated design, minimal component
- 1.0mA (typ.) Shutdown current (BL3212)



Applications

- Flash LED driver
- White LED display and keypad backlight
- Cell Li-ion battery-operated equipment including PDAs, hand-held PCs, cellular phone



Description

The IS31BL3230 provides eight regulated current sources of up to 40mA of load current each, while the IS31BL3212 provides four regulated current sources of up to 23mA of load current each. All the outputs can be connected in parallel to combine the currents for up to 320mA [BL3230] or 92mA [BL3212] flowing through one LED. They require no charge pump, have no EMI noise and have significantly improved efficiency.

Part No.	Channels	Current Source (mA)	Package	Package Outline
IS31BL3230	8	40	QFN-16	
IS31BL3212	4	23	DFN-8	
	3	23	SOT23-6	

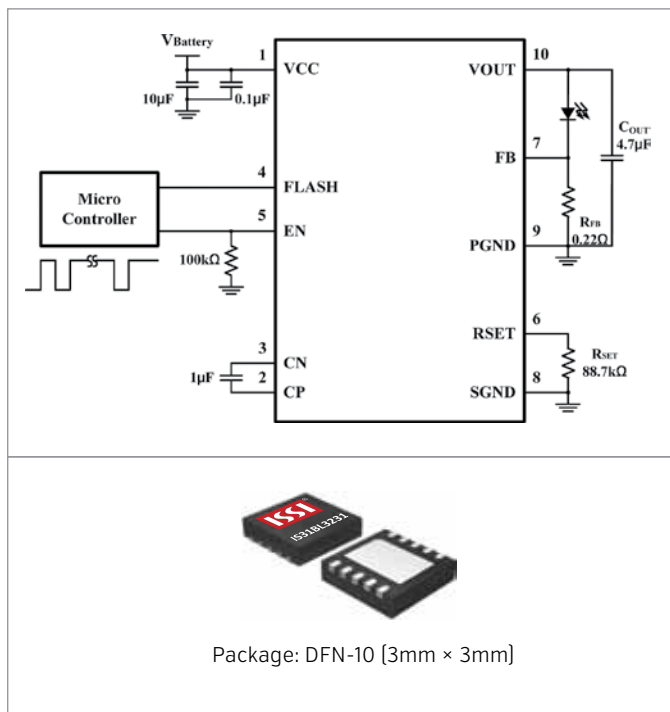

IS31BL3231 & IS31BL3232

- Flash LED Driver

Features

- Operates from 2.7V to 5.5V
- Up to 90% efficiency in Torch Mode
- Output current: IS31BL3231 - up to 750mA, IS31BL3232 - up to 1.2A
- 1 sec flash time out to protect LED [IS31BL3232]
- Adjustable output current in Flash Mode
- Minimum external components, no external inductor required
- Automatic boost mode
- Less than 1mA shutdown current
- Low ripple and EMI
- Over voltage protection on output
- Short and over temperature protections

Applications

- White LED backlighting
- Cellular phones
- Generic lighting/flash/strobe applications

Description

These devices are integral current-regulated charge pump and ideal for powering high brightness LEDs for camera flash and torch applications. The charge pump can be set to regulate two current levels for FLASH and TORCH modes. They automatically switch between linear and boost modes ensuring that LED current does not depend on the LED forward voltage.

They provide a low cost, space saving solution for driving LED. It also integrates thermal and short circuit protection function.

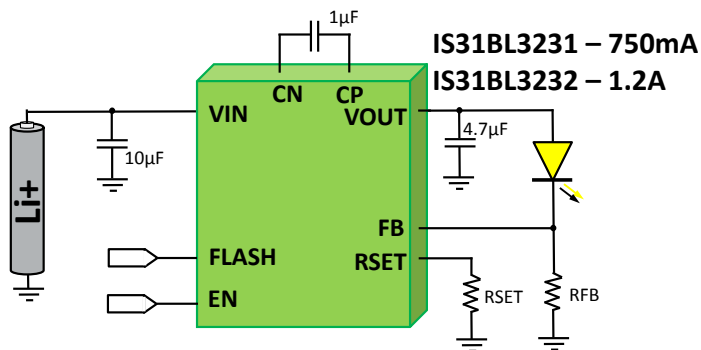

Part No.	Flash mode (mA)	Package
IS31BL3231	750	DFN-10
IS31BL3232	1,200	DFN-10

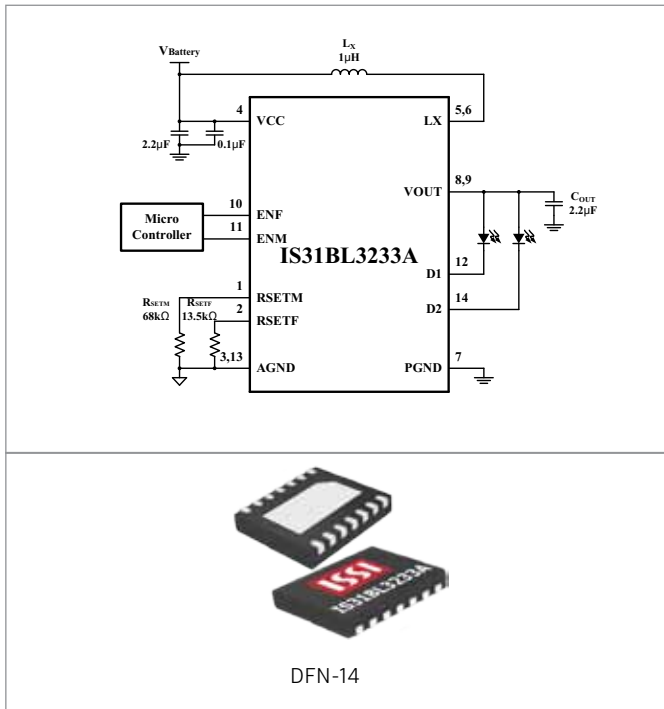

IS31BL3233A - 1.5A Dual Channel

Features

- Input voltage range: 2.7V~5.5V
- Dual flash LED outputs
- Drive up to total 1.5A or 0.75A per channel
- 1s time out in Flash Mode to protect LED
- High efficiency LED driver (up to 93%)
- 2MHz step-up converter
- Very small inductor: 1.0mH
- Movie/torch-mode dimming via PWM control
- Integrated thermal regulation control
- LED open/short protection
- Over-voltage protection
- Cycle-by-cycle inductor current limit
- 0.1mA shutdown current
- Pb-free package: DFN-14 (2mm×3mm)
- -40C° ~ +85C° temperature range

Applications

- Mobile phones
- Smart phones and PDAs
- Digital still cameras

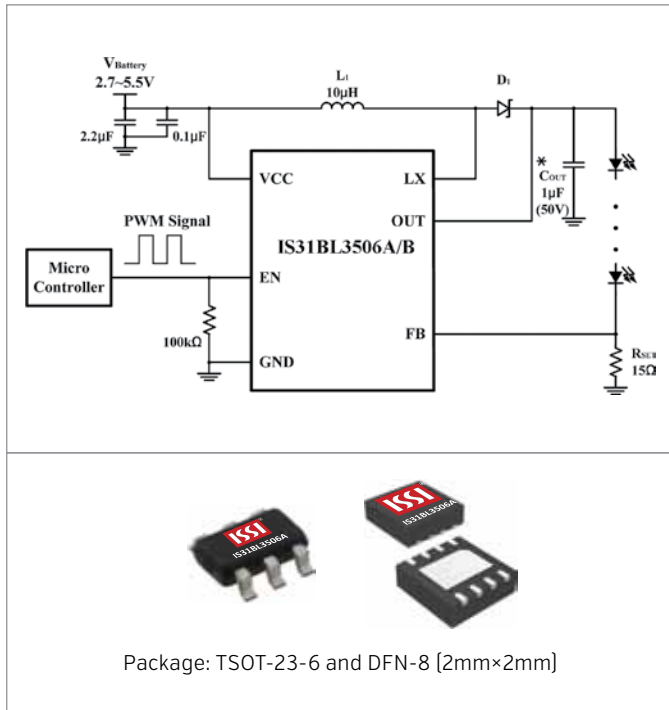

IS31BL3506A/B - 1.0MHz Boost Converter

Features

- 35V Internal MOSFET Switch
- Supply voltage: 2.7V~5.5V
- Built-in soft start
- Drive series strings of
 - 9 LEDs in series (DFN-8)
 - 8 LEDs in series (TSOT-23-6)
- PWM or DC voltage dimming
- Frequency of PWM is 500Hz ~ 500kHz
- 1.0MHz high speed switching frequency
- Feedback voltage:
 - 300mV (IS31BL3506A)
 - 200mV (IS31BL3506B)
- Over voltage protection
 - 40°C ~ +85°C working temperature range

Applications

- Small LCD Backlights
- Notebook PC
- GPS

Description

IS31BL3506 is a boost converter featuring an integrated MOSFET switch designed for driving series strings of LEDs. The input operating voltage range is 2.7V~5.5V. The regulated LED load current is set using an external, low value sensing resistor. The device adjusts the PWM duty cycle of the switch to maintain the voltage at the FB pin. The IS31BL3506 operates at a constant switching frequency of 1.0MHz to allow for small component size. IS31BL3506 features an over voltage shutdown pin which prevents the output voltage from exceeding 35V [typ.] in the case of an open circuit condition.



Part No.	LEDs	V _{FB}	Package
IS31BL3506A	8	300mV	TSOT23-6
	9		DFN-8
IS31BL3506B	8	200mV	TSOT23-6 SOT23-6

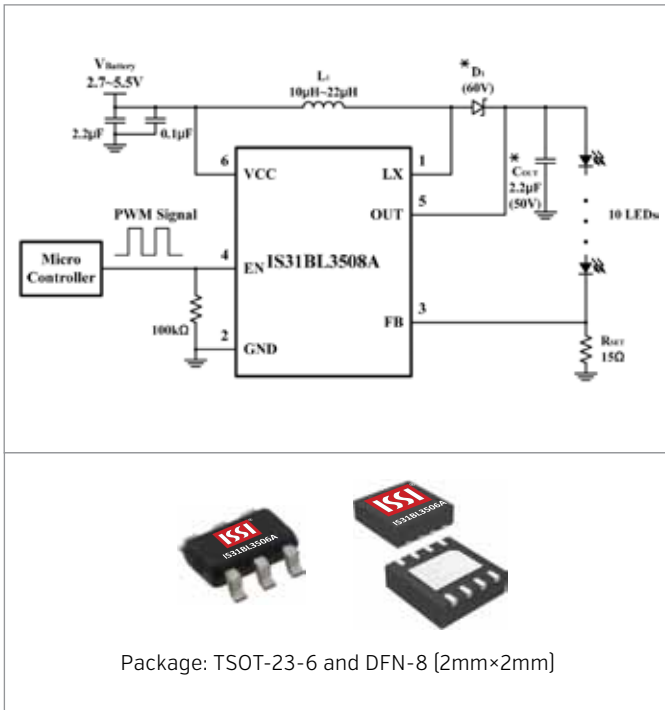

IS31BL3508A/B - 1.0MHz Boost Converter

Features

- 38V Internal MOSFET Switch
- Supply voltage: 2.7V~5.5V
- Built-in soft start
- Drive series strings of 10 LEDs or 3x8 LEDs
- PWM or DC voltage dimming
- Frequency of PWM is 500Hz ~ 500kHz
- 1.0MHz high speed switching frequency
- Feedback voltage:
300mV [IS31BL3508A]
200mV [IS31BL3508B]
- Over voltage protection
- -40°C ~ +85°C working temperature range



Applications

- Small LCD Backlights
- Notebook PC
- GPS

Description

IS31BL3508A is a 1.0MHz boost converter featuring an integrated MOSFET for driving series strings of upto 10 LEDs. With an operating voltage range of 2.7V~5.5V, an external sense resistor is all that is necessary to regulate the LED load current. The device adjusts the switch PWM duty cycle to maintain the FB pin voltage. It features an over voltage shutdown pin which prevents the output voltage from exceeding 38V [typ.] in case of an open circuit condition.

Part No.	LEDs	VFB	Package
IS31BL3508A	10	300mV	TSOT23-6, SOT23-6
IS31BL3508B	10	200mV	TSOT23-6 SOT23-6

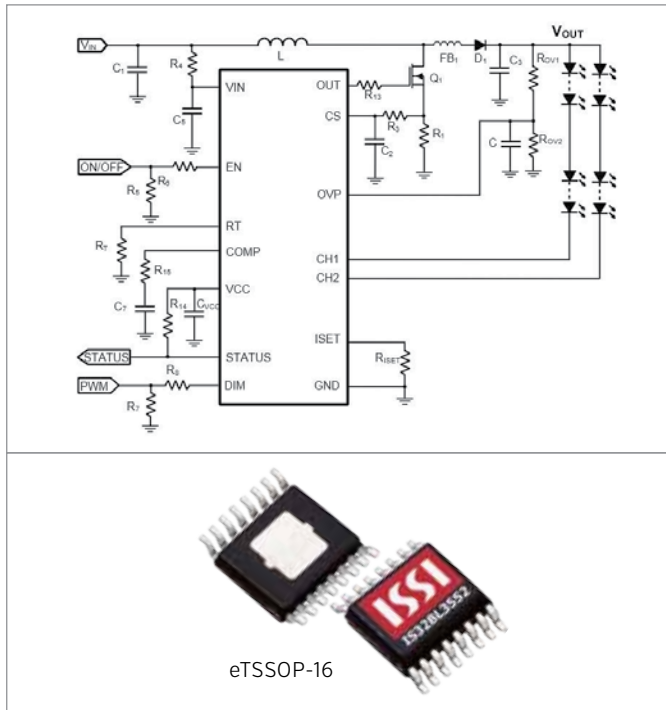

IS32BL3552 - Two Channel Boost

Features

- 2 current sinks adjustable 40 to 360mA
 - String-to-string current matching of 1.5%
 - High contrast ratio
 - External PWM dimming
- Input voltage range: 4.5V to 33V
- Operating frequency: 100kHz to 1MHz
- Protections for: OCP, OTP, UVLO, LED open/short, programmable OVP
- Automotive AEC-Q100 Qualified

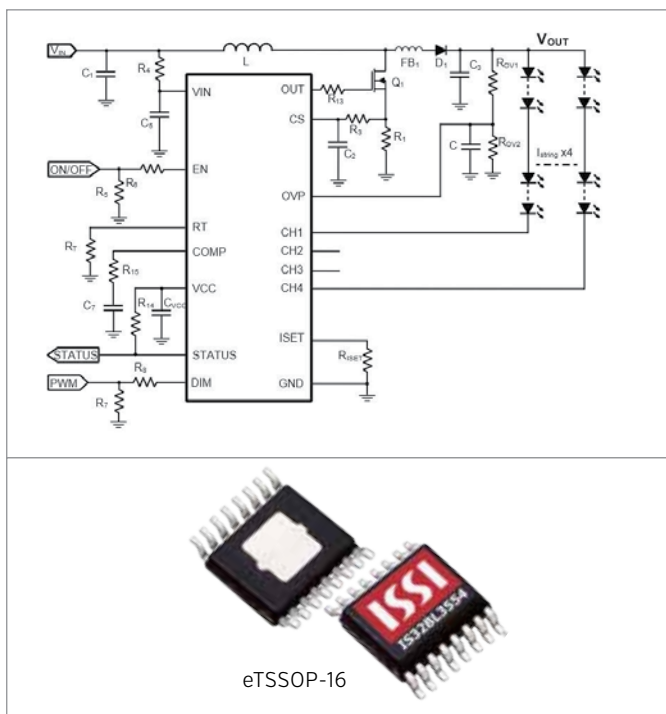

IS32BL3554 - Four Channel Boost

Features

- 4 current sinks adjustable 20 to 180mA
 - String-to-string current matching of 1.5%
 - High contrast ratio
 - External PWM dimming
- Input voltage range: 4.5V to 33V
- Operating frequency: 100kHz to 1MHz
- Protections for: OCP, OTP, UVLO, LED open/short, programmable OVP
- Automotive AEC-Q100 Qualified

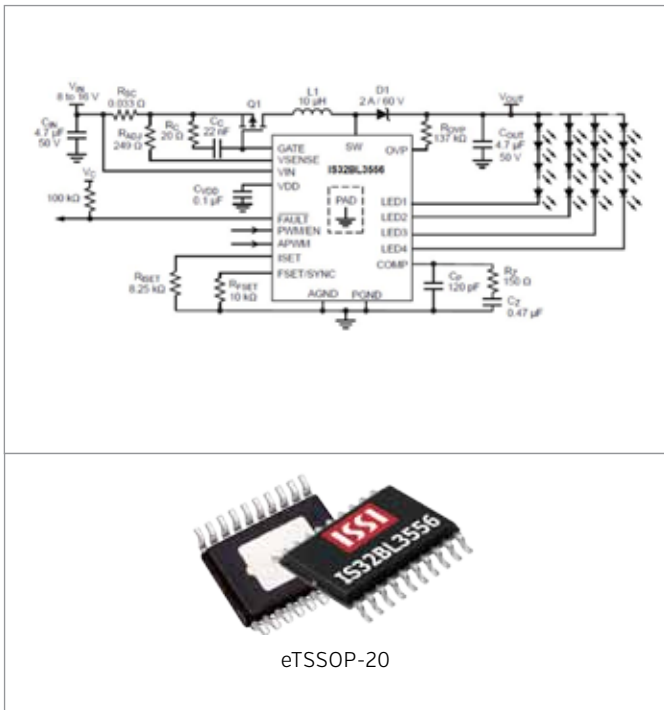
**IS32BL3556** - Four Channel Boost

Features

- 4 current sinks adjustable up to 100mA
 - String-to-string current matching of 0.8%
 - High contrast ratio
 - External PWM dimming
- Input voltage range: 4.75V to 40V
- Integrated Power MOSFET
- Operating frequency upto 2.3MHz
 - Synchronize capable
- Protections for: OCP, OTP, UVLO, LED open/short, programmable OVP
- Provide driver for external PMOS input disconnect switch
- Automotive AEC-Q100 Qualified [Pending]

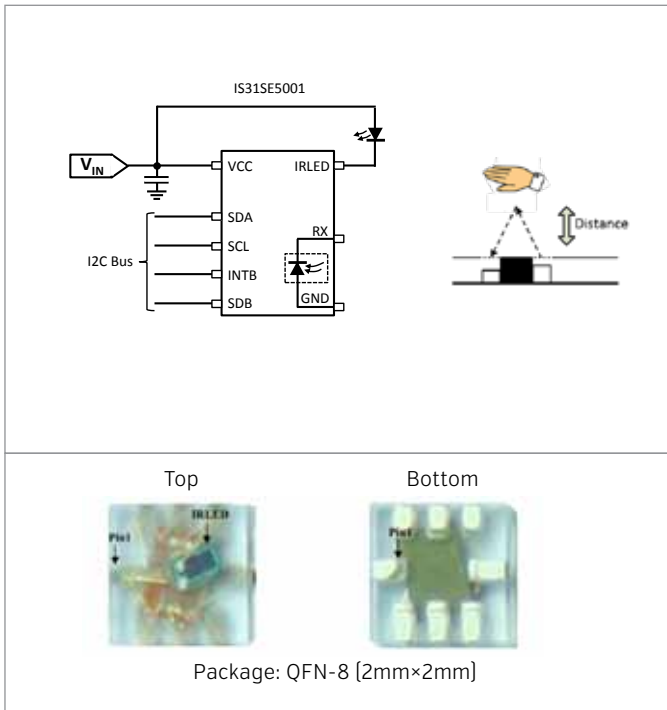

IS31SE5001 - Infrared Proximity Detection

Features

- Supply voltage from 2.7V~5.5V @ 0.6mA and 1mA shutdown current
- Integrated signal processing and digital output
- Detection range can be adjusted thru software
- 400kHz I2C compatible interface
- Interrupt signal is automatically cleared

Description

The IS31SE5001 is a low-power, reflectance-based infrared light sensor with advanced signal processing and an I2C interface. It uses one infrared LED transmitter and an integrated receiver to pick up the reflectance signal for touchless proximity detection. When a proximity motion is detected, the IS31SE5001 sets a flag bit in the status register and then generates an interrupt signal to inform the master to read the flag bit through the I2C interface.

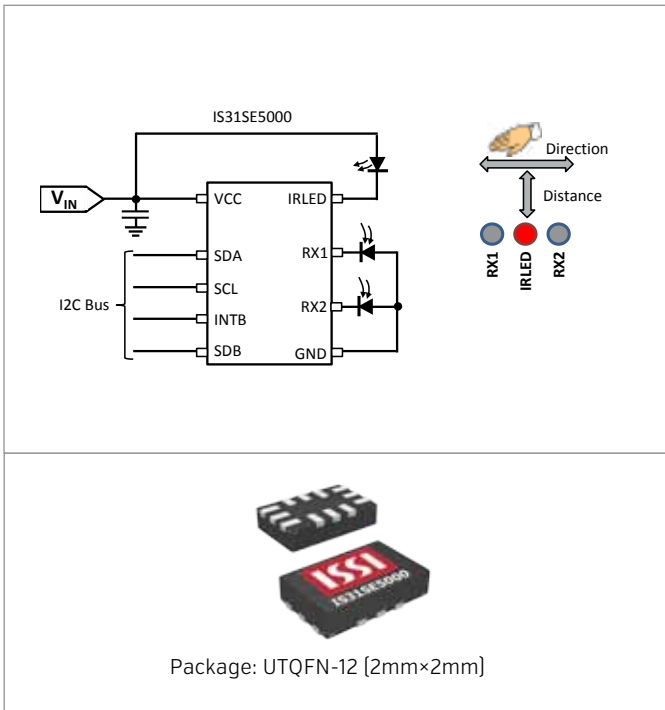

IS31SE5000 - Infrared Gesture Detection

Features

- Supply voltage from 2.7V~5.5V @ 0.6mA and 1mA shutdown current
- Dual receiver input and one transmitter
- Integrated signal processing and digital output
- Detection range can be adjusted thru software
- 400kHz I2C compatible interface
- Interrupt signal is automatically cleared

Description

The IS31SE5000 is a low-power, reflectance-based infrared light sensor with advanced signal processing and an I2C interface. The IS31SE5000 uses one infrared LED and 2-channel receivers which pick up the reflectance signal from the photodiodes. When horizontal motion or proximity motion is detected, the flag bits in the status register will be triggered and an interrupt signal is generated to inform the master to read the flag bit through I2C interface.

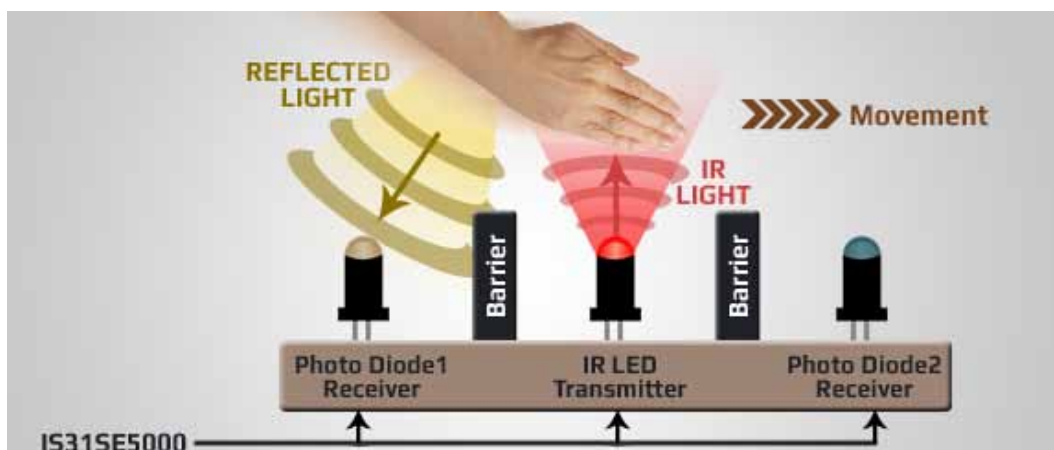

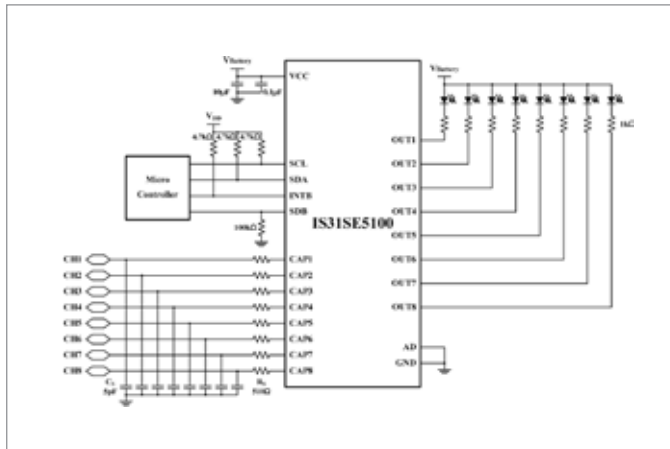

IS31SE5100 and IS31SE5104 - Capacitive Touch Sensor

Features

- Supply voltage from 2.7V~5.5V @ 0.4mA and 2mA shutdown current
- Extremely low power optimized for portable applications
- Complete capacitive touch sensor controller with auto offset compensation
- Integrated signal processing and digital output
- Sensitivity adjustable by external capacitor or internal register
- Interrupt driven fast-mode I²C interface [400KHz]
- IS31SE5100 - 8 cap sensors with 8 LED outputs
- IS31SE5104 - 4 cap sensors with 4 LED outputs

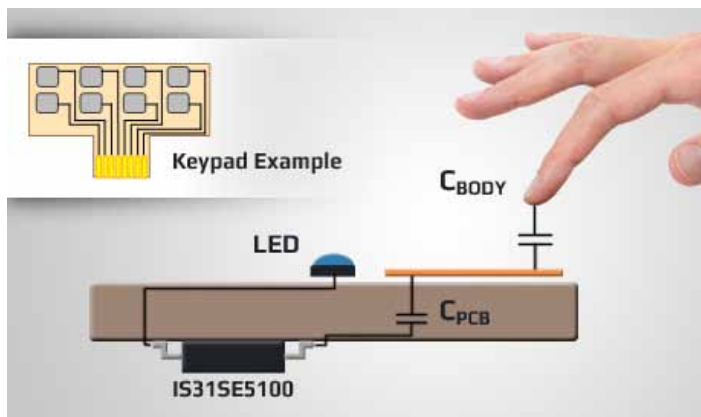

Description

The IS31SE5100 and IS31SE5104 are ultra-low power, fully integrated 8 and 4-channel capacitive touch controllers. They project sense fields through any dielectric such as glass or plastic. On-chip calibration logic continuously monitors the environment and automatically adjusts on-and-off threshold levels to prevent false sensor activation.

They support a fast 400kHz I²C serial bus data transfer with a programmable slave address. An interrupt is generated every time a sense electrode is touched or released

Product Selector Guide

FxLED Driver

Part No.	No. of Channel	No. RGB Group	Gamma Correction	Control Interface	Audio Sync.	Auto Dimming	VDD [V]	Package [Size mm]	Key Feature	Status
IS31FL3191	1	-	Built-in	I ² C	No	Yes	2.7-5.5	UTQFN-9 [1.5x1.5]	Single LED driver with auto breath mode and 5 levels programmable current	Prod
IS31FL3193	3	1	Built-in	I ² C	No	Yes	2.7-5.5	DFN-10 [3.0x3.0]	16Million color RGB auto and semi-auto breathing with pre-set pattern	Prod
IS31FL3193C	3	1	Built-in	I ² C	No	Yes	2.7-5.5	WLCSP-8 [1.5x1.0]	16Million color RGB auto and semi-auto breathing with pre-set pattern	S=Q1/15
IS31FL3196	6	2	Built-in	I ² C	Yes	Yes	2.7-5.5	QFN-20 [3.0x3.0]	16Million color RGB auto and semi-auto breathing with pre-set pattern	Prod
IS31FL3199	9	3	Built-in	I ² C	Yes	Yes	2.7-5.5	QFN-20 [3.0x3.0]	16Million color RGB auto and semi-auto breathing with AGC Audio Sync mode	Prod
IS31FL3216	16	-	External	I ² C	Yes	No	2.7-5.5	QFN-28 [4.0x4.0]	Audio modulated, Internal SRAM supports animation frames, 16 independent channels	Prod
IS31FL3218	18	-	External	I ² C	No	No	2.7-5.5	QFN-24 [4.0x4.0] SOP-24 [10x15]	Modulate 18 Independent LED channels with 256 steps PWM	Prod
IS31FL3235	28	-	External	I ² C	No	No	2.7-5.5	QFN-36 [4.0x4.0]	Modulate 28 Independent LED channels with 256 steps PWM	Prod
IS31FL3236	36	-	External	I ² C	No	No	2.7-5.5	QFN-44 [5.0x5.0] TQFP-48	Modulate 36 Independent LED channels with 256 steps PWM	Prod
IS31FL3726	16	-	-	Serial	No	No	3.3-5.5	QFN-24 [4.0x4.0] TSSOP-24	16-channels On/Off LED driver with serial-in and serial-out for cascade application	Prod
IS31FL3728	16 Matrix 64	-	External	I ² C	Yes	No	2.7-5.5	QFN-24 [4.0x4.0]	16-row/column outputs, Audio Modulated. 8x8,7x9,6x10,5x11 matrix arrays.	Prod
IS31FL3730	16 Matrix 128	-	External	I ² C	Yes	No	2.7-5.5	QFN-24 [4.0x4.0]	16-row/column outputs, Audio Modulated. 8x8,7x9,6x10,5x11 bi-color matrix arrays.	Prod
IS31FL3731	18 Matrix 144	-	External	I ² C	Yes	Yes	2.7-5.5	QFN-28 [4.0x4.0] SSOP-28	18 row/column outputs. Audio Modulated, Two 8x9 arrays with SRAM. 8-image swapping 8x9x2 [144 dot] LED array display	Prod
IS31FL3731C	18 Matrix 144	-	External	I ² C	Yes	Yes	2.7-5.5	QFN-28 SSOP-28	18 row/column outputs. Audio Modulated, Two 8x9 arrays with SRAM. 8-image swapping 8x9x2 [144 dot] LED array display, Within robust I2C for white goods application	Prod
IS31FL3732	18 Matrix 144	-	External	I ² C	Yes	Yes	2.7-5.5	QFN-40	18 row/column outputs. Audio Modulated, Two 8x9 arrays with SRAM. 8-image swapping 8x9x2 [144 dot] LED array display. With 1MHz I2C, Cascade for Synchronization	S=Q1/15

Product Selector Guide cont'd

White LED Driver for LCD Backlight & Flash

Part No.	No. of LED	Type of Driver	IOUT [mA]	VDD [V]	ISD [uA]	Intensity Control	Package [Size in mm]	Key Feature	Status
IS31BL3212	3/4	Constant Current	23	2.7 - 5.5	1.0	Pulse Count	SOT23-6 [3.0x3.0], DFN-8 [2.0x2.0]	Ultra low headroom voltage, highly integrated design with minimal component	Prod
IS31BL3228A/B	4/6	Constant Current	20	2.8 - 5.5	0.5	Pulse Count	UTQFN-12	4 channel with 14 programmable current levels	Prod
IS31BL3229	8	Constant Current w/charge pump	25	2.7 - 5.5	1.0	PWM	QFN-20 [3.0x3.0]	8 channel output with built-in charge pump for high efficiency mode [1x/1.5x]	Prod
IS31BL3230	8	Constant Current	40mA or 320mA in parallel	2.7 - 5.5	1.6	PWM	QFN-16 [3.0x3.0]	Ultra low headroom voltage. All outputs may be connected in parallel	Prod
IS31BL3231	1	Charge Pump	750	2.7 - 5.5	1.0	Pulse Count	DFN-10 [3.0x3.0]	Camera Flash LED Driver	Prod
IS31BL3232	1	Charge Pump	1200	2.5 - 5.5	1.0	Pulse Count	DFN-10 [3.0x3.0]	Camera Flash LED Driver with time out protection	Prod
IS31BL3233A	2	Boost	750	2.7-5.5	1.0	PWM	DFN-14[2.0x3.0]	2x750mA Boost Camera Flash LED Driver with time out protection	Prod
IS31BL3506A	9	Boost	20	2.7 - 5.5	1.5	PWM or DC Level	TSOT23-6 [3.0x3.0] DFN-8 [2.0x2.0]	35V Internal MOSFET 1MHz Step-up Converter; VFB = 300mV	Prod
IS31BL3506B	8	Boost	20	2.7 - 5.5	1.5	PWM or DC Level	TSOT23-6 [3.0x3.0]	35V Internal MOSFET 1MHz Step-up Converter; VFB = 200mV	Prod
IS31BL3508A/B	10	Boost	20-160	2.7 - 5.5	2.0	PWM or DC Level	TSOT23-6 [3.0x3.0] SOT23-6 [3.0x3.0]	1.0MHz Boost Converter with 38V internal switch; VFB = 300mV	Prod

Automotive Backlight LED Drivers

Part No.	Driver	VIN [V]	IOUT Accuracy	Power Transistor	Typical Applications	Package	Key Feature	Status
IS32BL3552	DC/DC Boost	4.5 - 33V	±1.5%	External	Automotive lighting, LCD display backlight	eTSSOP-16	Two channel LED current sinks, 40 to 360mA per string. String-to-string accuracy 1.5%	Sample
IS32BL3554	DC/DC Boost	4.5 - 33V	±1.5%	External	Automotive lighting, LCD display backlight	eTSSOP-16	Four 20 to 180mA channel current sinks. String-to-string accuracy 1.5%	Sample
IS32BL3556	DC/DC Boost	4.75-40V	±0.8%	External	Automotive lighting, LCD display backlight	eTSSOP-20	Four 100mA channel current sinks, Integrated Power MOS, String-String accuracy 0.8%	S=Q2/15

Sensor

Device	Sensor Type	VIN [V]	No. Channels	Package	Key Feature	Status
IS31SE5000	Gesture Sensor/ Proximity	2.7-5.5	1 Trans, 2 Recv	UTQFN-12 [2x2]	IR Light Sensor for gesture or movement detection	Prod
IS31SE5001	Proximity Sensor	2.7-5.5	1 Trans, 1 Recv [Integrated]	QFN-8 [2x2]	IR Light Sensor for proximity detection	Prod
IS31SE5100	Capacitive Touch	2.7-5.5	8 Cap Touch Input, 8 LED Drive Output	QFN-24, SSOP-24	Capacitance sensor, 8 sense plate input with 8 LED outputs	Prod
IS31SE5104	Capacitive Touch	2.7-5.5	4 Cap Touch Input, 4 LED Drive Output	SOP-16, QFN-16	Capacitance sensor, 4 sense plate input with 8 LED outputs	Prod

FxLED*

Device	Evaluation Board	Description
IS31FL3193-DLS2	IS31FL3193-DLS2-EB	3-Channel LED Driver
IS31FL3199-QFLS2	IS31FL3199-QFLS2-EB	9-Channel LED Driver
IS31FL3216-QFLS2	IS31FL3216-QFLS2-EB	16-Channel LED Driver
IS31FL3218-GRLS2	IS31FL3218-GRLS2-EB	18-Channel LED Driver
IS31FL3236-QFLS2	IS31FL3236-QFLS2-EB	36-Channel LED Driver
IS31FL3726-QFLS2	IS31FL3726-QFLS2-EB	16-Bit Serial w/PWM Control LED Driver
IS31FL3728-QFLS2	IS31FL3728-QFLS2-EB	64-Matrix Audio Modulated LED Driver
IS31FL3730-QFLS2	IS31FL3730-QFLS2-EB	128-Matrix Audio Modulated LED Driver
IS31FL3731-QFLS2	IS31FL3731-QFLS2-EB	144-Matrix Audio Modulated LED Driver

Sensor*

Device	Evaluation Board	Description
IS31SE5000	IS31SE5000-UTLS2-EB	IR Sensor for Touchless Motion and Proximity
IS31SE5001	IS31SE5001-QFLS2-EB	IR Sensor for Proximity Detection
IS31SE5100	IS31SE5100-QFLS2-EB	8-Channel Capacitive Touch Sensor

Backlight*

Device	Evaluation Board	Description
IS31BL3212-STLS2-TR	IS31BL3212-STLS2-EB	4 Channel constant current, 23mA
IS31BL3228B-UTLS2-TR	IS31BL3228B-UTLS2-EB	6 Channel constant current, 20mA
IS31BL3230-QFLS2-TR	IS31BL3230-QFLS2-EB	8 Channel constant current, 40mA
IS31BL3231-DLS2-TR	IS31BL3231-DLS2-EB	Flash (750mA) and Torch
IS31BL3232-DLS2-TR	IS31BL3232-DLS2-EB	Flash (1,200mA) and Torch
IS31BL3506A-DLS2-TR	IS31BL3506A-DLS2-EB	9 LED string @ 20mA
IS31BL3506A-TTLS2-TR	IS31BL3506A-TTLS2-EB	8 LED string @ 20mA
IS31BL3506B-STLS2-TR	IS31BL3506B-STLS2-EB	9 LED string @ 20mA
IS31BL3508A-TTLS2-TR	IS31BL3508A-TTLS2-EB	10 LED string @ 30mA

* Note : Visit www.issi.com for a complete list of Evaluation Boards.

Analog Part Number Decoder

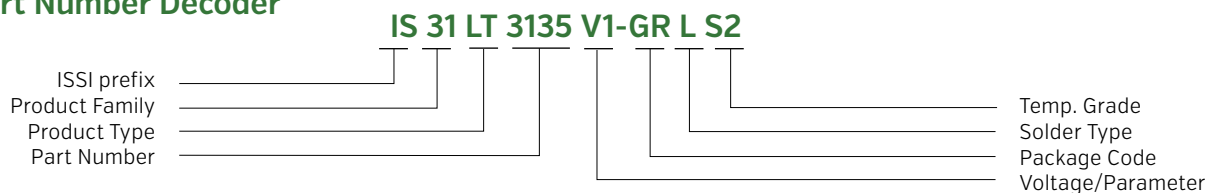

• Analog Product Family

- 31 = Commercial/Industrial Analog
- 32 = Automotive Analog and Mixed Signal

• Product Type

- AP = Audio Power Amplifier
- BL = White LED Driver for LCD Backlight
- FL = FxLED Driver
- LT = Lighting LED Driver
- SE = Sensor

• Temperature Grade

- S1 = Commercial (0°C to 70°C)
- S2 = Industrial temp. [-40°C to 85°C]
- S3 = Industrial temp. [-40°C to 105°C]
- S4 = Industrial temp. [-40°C to 125°C]
- A1 = Automotive Grade [-40°C to +85°C]
- A2 = Automotive Grade [-40°C to +105°C]
- A3 = Automotive temp. [-40 to 125°C]

• Solder Type

- Blank = Sn/Pb
- L = Lead-free (RoHS Compliant)

• Package Type

- C = WCSP
- D = DFN
- GR = SOP
- QF = QFN
- S = MSOP
- SD = SOT89
- ST = SOT23
- TT = TSOT23
- UT = UTQFN
- Z = TSSOP

• Voltage Range / Parameters

- Sense Voltage Range
- V1 = 91mV to 101mV
- V2 = 99mV to 110mV
- Under-Voltage Range
- V1 = 1.13V to 1.21V
- V2 = 1.19V to 1.26V

Advanced Memory Solutions

Innovative Analog and Mixed Signal Solutions

ISSI Sales Offices

*HEADQUARTERS West Coast Office Milpitas, CA, USA 408-969-6600 Tel. 408-969-7800 Fax	China Office Beijing 86-10-82274081 Tel. 86-10-82274082 Tel. 86-10-82274079 Fax	China Office Xiamen City 86-592-3228128 Tel. 86-592-3228077 Fax	India Office New Delhi/NCR 91-124-4696642 Tel. 91-124-4696940 Fax	Japan Office Tokyo 81-3-5339-2950 Tel. 81-3-5339-2951 Fax
Central Office Copell, TX, USA 972-571-5108 Tel. 408-969-7090 Fax	China Office Shanghai 86-21-50802288 Tel. 86-21-50802028 Fax	Taiwan Office Hsin-Chu 886-3-5780333 Tel. 886-3-5783000 Fax	India Office Bangalore 91-80-41472556 Tel. 91-80-41472554 Fax	Korea Office Kyunggi-Do 82-31-715-6406 Tel. 82-31-715-6209 Fax
East Coast Office Dunstable, MA, USA 978-649-1216 Tel. 978-649-3208 Fax	China Office Shenzhen 86-755-88319800 Tel. 86-755-88319810 Fax	Taiwan Office Taipei 886-2-26962140 Tel. 886-2-26962252 Fax	India Office Chennai 91-44-42994392 Tel. 91-44-42994300 Fax	Singapore Office +65-6316-3035 Tel. +65-6316-3039 Fax
Southeast Office Raleigh, NC, USA 919-844-5873 Tel.	China Office Hong Kong 852-23192211 Tel. 852-23192004 Fax	Europe Office Devon England 44-1803-840110 Tel. 44-1803-865199 Fax		



1623 Buckeye Drive, Milpitas, CA 95035
p 408-969-6600 | f 408-969-7800 | analog@issi.com | www.issi.com

© 2015, ISSI, Inc. All Rights Reserved. ISSI is a registered trademark of Integrated Silicon Solution, Inc.



Компания «ЭлектроПласт» предлагает заключение долгосрочных отношений при поставках импортных электронных компонентов на взаимовыгодных условиях!

Наши преимущества:

- Оперативные поставки широкого спектра электронных компонентов отечественного и импортного производства напрямую от производителей и с крупнейших мировых складов;
- Поставка более 17-ти миллионов наименований электронных компонентов;
- Поставка сложных, дефицитных, либо снятых с производства позиций;
- Оперативные сроки поставки под заказ (от 5 рабочих дней);
- Экспресс доставка в любую точку России;
- Техническая поддержка проекта, помощь в подборе аналогов, поставка прототипов;
- Система менеджмента качества сертифицирована по Международному стандарту ISO 9001;
- Лицензия ФСБ на осуществление работ с использованием сведений, составляющих государственную тайну;
- Поставка специализированных компонентов (Xilinx, Altera, Analog Devices, Intersil, Interpoint, Microsemi, Aeroflex, Peregrine, Syfer, Eurofarad, Texas Instrument, Miteq, Cobham, E2V, MA-COM, Hittite, Mini-Circuits, General Dynamics и др.);

Помимо этого, одним из направлений компании «ЭлектроПласт» является направление «Источники питания». Мы предлагаем Вам помощь Конструкторского отдела:

- Подбор оптимального решения, техническое обоснование при выборе компонента;
- Подбор аналогов;
- Консультации по применению компонента;
- Поставка образцов и прототипов;
- Техническая поддержка проекта;
- Защита от снятия компонента с производства.



Как с нами связаться

Телефон: 8 (812) 309 58 32 (многоканальный)

Факс: 8 (812) 320-02-42

Электронная почта: org@eplast1.ru

Адрес: 198099, г. Санкт-Петербург, ул. Калинина, дом 2, корпус 4, литера А.