

Features

- Precision reference voltage
AP432 : 1.24V ± 1%
AP432A : 1.24V ± 0.5%
- Sink current capability: 200mA
- Minimum cathode current for regulation: 150µA
- Equivalent full-range temp coefficient: 30 ppm/°C
- Fast turn-on response
- Low dynamic output impedance: 0.2Ω
- Programmable output voltage to 20V
- Low output noise
- Packages: SOT23, SOT23R, SOT25, SC59 (W package code), SC59 (R package code), SOP-8L and TO92-3L
- SOT23, SOT23R, SOP-8L and SC59: Available in "Green" Molding Compound (No Br, Sb) (Note 1)
- Lead Free Finish/ RoHS Compliant for Lead Free and "Green" Products (Note 2)

General Description

The AP432/432A are 3-terminal adjustable precision shunt regulators with guaranteed stable temperature over the applicable extended commercial temperature range. The output voltage may be set at any level greater than 1.24V (V_{REF}) up to 20V merely by selecting two external resistors that act as a voltage divider network. These devices have a typical output impedance of 0.2Ω. Active output circuitry provides very sharp turn-on characteristics, making these devices excellent improved replacements for Zener diodes in many applications.

The precise +/- 1% reference voltage tolerance of the AP432/432A make it possible in many applications to avoid the use of a variable resistor, consequently saving cost and eliminating drift and reliability problems associated with it.

Ordering Information

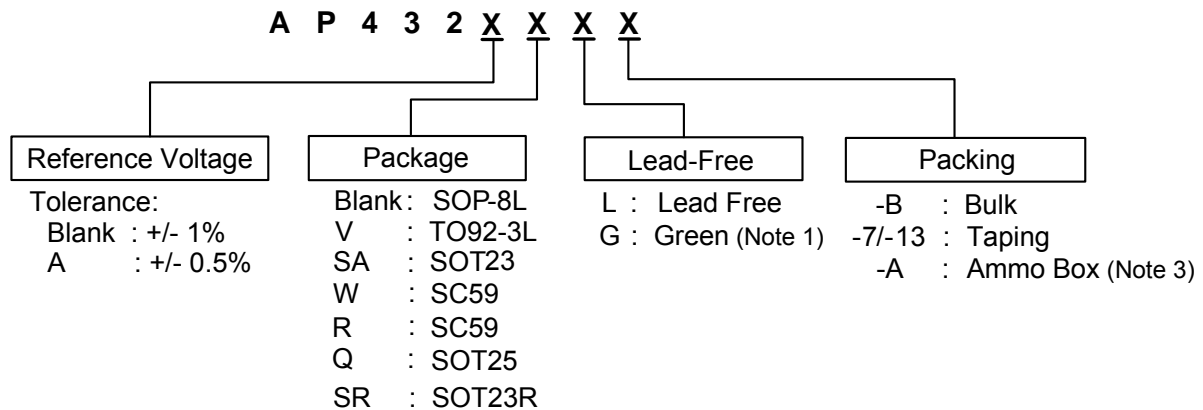

Note: 1. SOT23, SOT23R are "Green" products only.
2. RoHS revision 13.2.2003. Glass and High Temperature Solder Exemptions Applied, see *EU Directive Annex Notes 5 and 7*.

Device (Note 4)	Package Code	Packaging (Note 5)	7" Tape and Reel		13" Tape and Reel		Ammo Box	
			Quantity	Part Number Suffix	Quantity	Part Number Suffix	Quantity	Part Number Suffix
AP432(A)SA	SA	SOT23	3000/Tape & Reel	-7	NA	NA	NA	NA
AP432(A)SR	SR	SOT23R	3000/Tape & Reel	-7	NA	NA	NA	NA
AP432(A)Q	Q	SOT25	3000/Tape & Reel	-7	NA	NA	NA	NA
AP432(A)W	W	SC59	3000/Tape & Reel	-7	NA	NA	NA	NA
AP432(A)R	R	SC59	3000/Tape & Reel	-7	NA	NA	NA	NA
AP432(A)		SOP-8L	NA	NA	2500/Tape & Reel	-13	NA	NA
AP432(A)V	V	TO92-3L	NA	NA	NA	NA	2000/Box	-A

Notes: 3. Ammo Box is for TO92-3 Spread Lead.
4. Suffix "A" denotes AP432A device.
5. Pad layout as shown on Diodes Inc. suggested pad layout document AP02001, which can be found on our website at <http://www.diodes.com/datasheets/ap02001.pdf>.

Pin Assignment

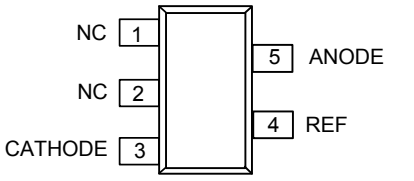
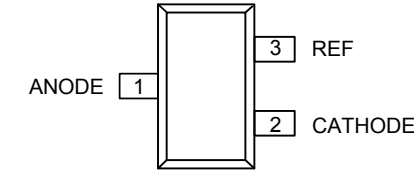
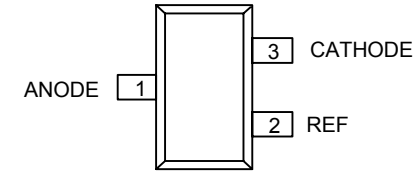
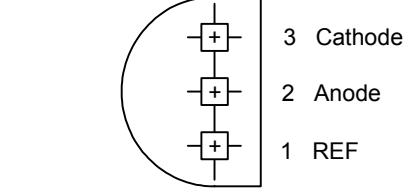
Package	Pin Configuration (Top View)
SOT25	 <p>NC 1 NC 2 CATHODE 3 4 REF 5 ANODE</p>
SC-59 (Package Code-W)	 <p>ANODE 1 2 CATHODE 3 REF</p>
SC-59 (Package Code-R)	 <p>ANODE 1 2 REF 3 CATHODE</p>
TO92-3L	 <p>3 Cathode 2 Anode 1 REF</p>

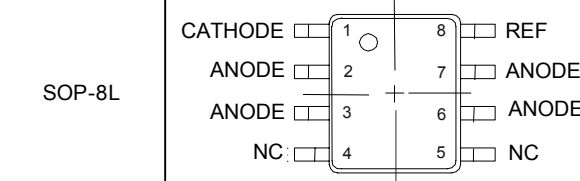
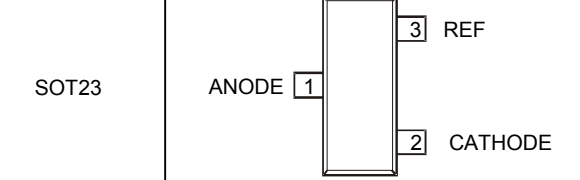
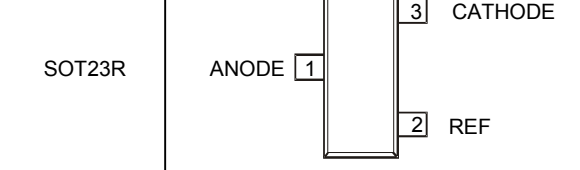
Package	Pin Configuration (Top View)
SOP-8L	 <p>CATHODE 1 ANODE 2 ANODE 3 NC 4 5 NC 6 ANODE 7 ANODE 8 REF</p>
SOT23	 <p>ANODE 1 2 CATHODE 3 REF</p>
SOT23R	 <p>ANODE 1 2 REF 3 CATHODE</p>

Typical Application Circuit

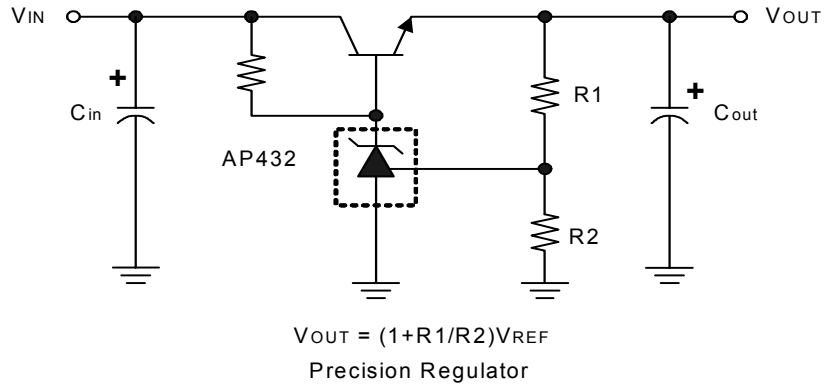

Block Diagram

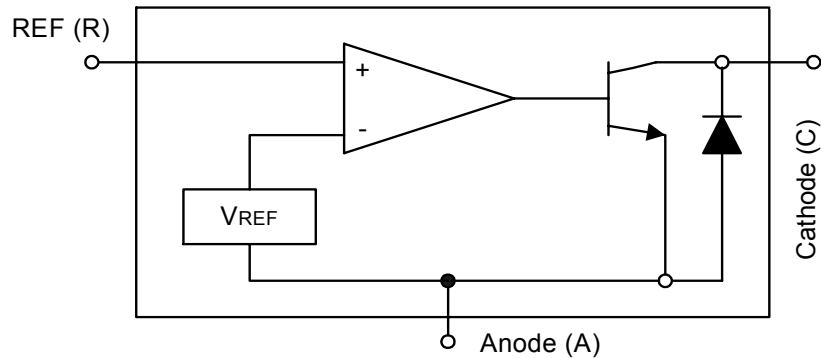

Symbol

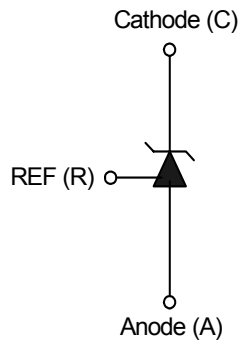

Absolute Maximum Ratings

Symbol	Parameter	Rating	Unit	
V _{CV}	Cathode Voltage	+20	V	
I _{CC}	Continuous Cathode Current	-10 to +250	mA	
I _{REF}	Reference Input Current	10	mA	
T _{OP}	Operating Temperature	-20 to +85	°C	
T _{ST}	Storage Temperature	-65 to +150	°C	
P _D	Power Dissipation (Notes 6, 7)	SOT23(R)	250	mW
		SOT25	250	mW
		SC59	400	mW
		SOP-8L	600	mW
		TO92-3L	780	mW

Note: 6. T_J, max =150°C
7. Ratings apply to ambient temperature at 25°C

Electrical Characteristics ($T_A = 25^\circ\text{C}$, $V^+ = +5.0\text{V}$, unless otherwise stated)

Parameter	Test conditions	Symbol	Min.	Typ.	Max.	Unit	
Reference Voltage	$V_{KA} = V_{ref}$, $I_{KA} = 10\text{mA}$ (Fig.1)	AP432 AP432A	V_{REF}	1.227 1.233	1.24	1.252 1.246	V
Deviation of Reference Input Voltage over Temperature (Note 8)	$V_{KA} = V_{REF}$, $I_{KA} = 10\text{mA}$, $T_a = \text{full range}$ (Fig.1)	V_{REF}		3.0	20	mV	
Ratio of the Change in Reference Voltage to the Change in Cathode Voltage	$I_{KA} = 10\text{mA}$ (Fig.2) $V_{KA} = 20 \sim V_{REF}$	$\frac{\Delta V_{REF}}{\Delta V_{KA}}$		-1.4	-2.0	mV/V	
Reference Input Current	$R1 = 10\text{K}\Omega$, $R2 = \infty$ $I_{KA} = 10\text{mA}$ (Fig.2)	I_{REF}		1.4	3.5	μA	
Deviation of Reference Input Current over Temperature	$R1 = 10\text{K}\Omega$, $R2 = \infty$ $I_{KA} = 10\text{mA}$ $T_a = \text{Full range}$ (Fig.2)	αI_{REF}		0.4	1.2	μA	
Minimum Cathode Current for Regulation	$V_{KA} = V_{REF}$ (Fig.1)	$I_{KA(\text{min})}$		0.15	0.3	mA	
Off-state Current	$V_{KA} = 20\text{V}$, $V_{REF} = 0\text{V}$ (Fig.3)	$I_{KA(\text{off})}$		0.1	1.0	μA	
Dynamic Output Impedance (Note 9)	$V_{KA} = V_{REF}$ Frequency $\leq 1\text{KHz}$ (Fig.1)	$ Z_{KA} $		0.2	0.5	Ω	

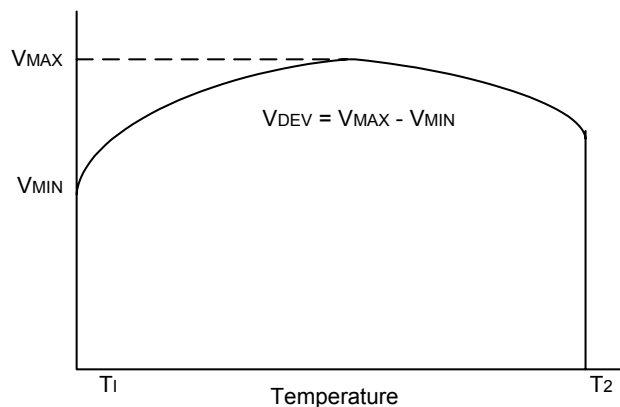

Note: 8. Deviation of reference input voltage, V_{DEV} , is defined as the maximum variation of the reference over the full temperature range. The average temperature coefficient of the reference input voltage αV_{REF} is defined as:

$$|\alpha V_{REF}| = \frac{\left(\frac{V_{DEV}}{V_{REF}(25^\circ\text{C})} \right) \cdot 10^6}{T_2 - T_1} \dots\dots\dots (\text{ppm}/^\circ\text{C})$$

Where:

$T_2 - T_1 =$ full temperature change.

αV_{REF} can be positive or negative depending on whether the slope is positive or negative.

Note: 9. The dynamic output impedance, R_z , is defined as:

$$|Z_{KA}| = \frac{\Delta V_{KA}}{\Delta I_{KA}}$$

When the device is programmed with two external resistors $R1$ and $R2$ (see Figure 2.), the dynamic output impedance of the overall circuit, is defined as:

$$|Z_{KA}'| = \frac{\Delta V}{\Delta I} \approx |Z_{KA}| \left(1 + \frac{R1}{R2} \right)$$

Test Circuits

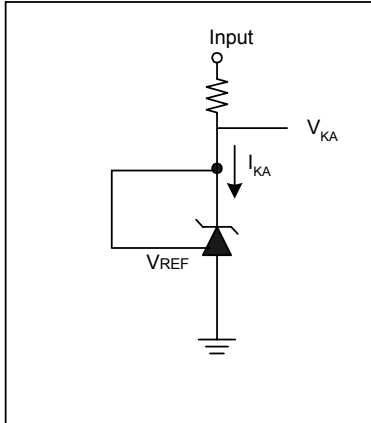
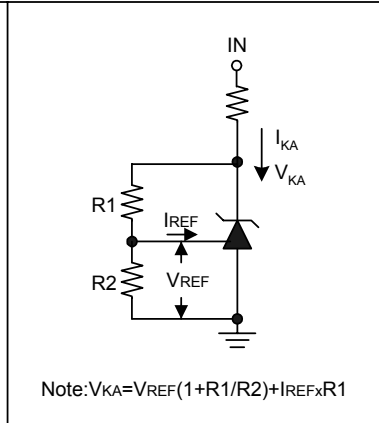

Fig 1. Test Circuit for $V_{KA} = V_{REF}$



Note: $V_{KA} = V_{REF}(1 + R1/R2) + I_{REF} \times R1$

Fig 2. Test Circuit for $V_{KA} > V_{REF}$

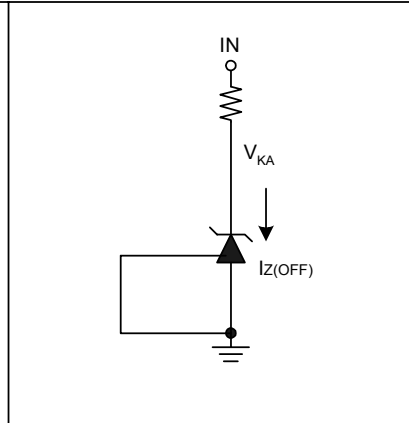
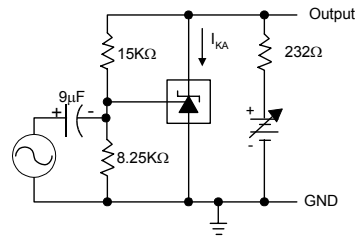
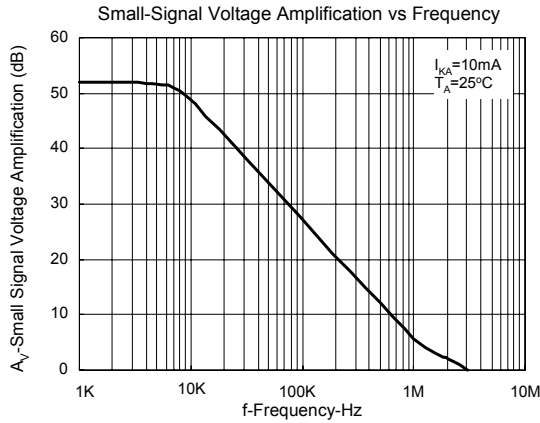
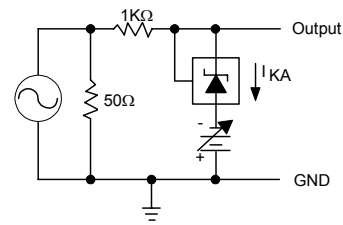
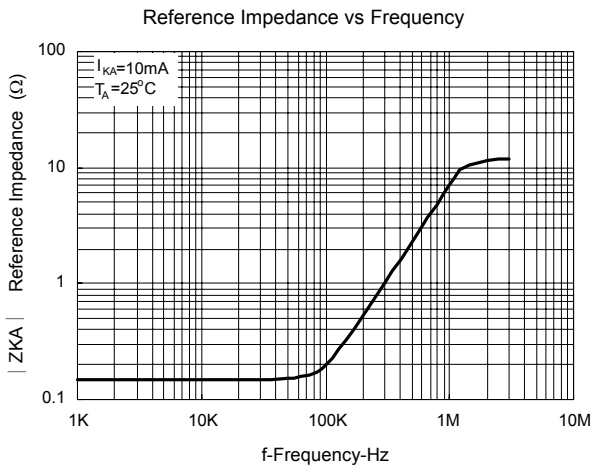

Fig 3. Test Circuit for Off-State Current

Typical Performance Characteristics



Test Circuit for Voltage Amplification



Test Circuit for Reference Impedance

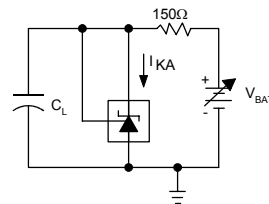
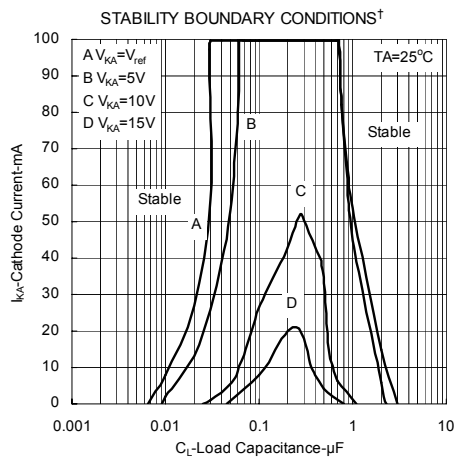

Test Circuit for Curve A

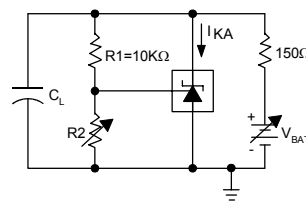

Test Circuit for Curve B, C, and D

†The areas under the curves represent conditions that may cause the device to oscillate. For curves B, C, and D, R2 and V+ were adjusted to establish the initial V_{KA} and I_{KA} conditions with C_L = 0. V_{BATT} and C_L were then adjusted to determine the ranges of stability.

Application Examples

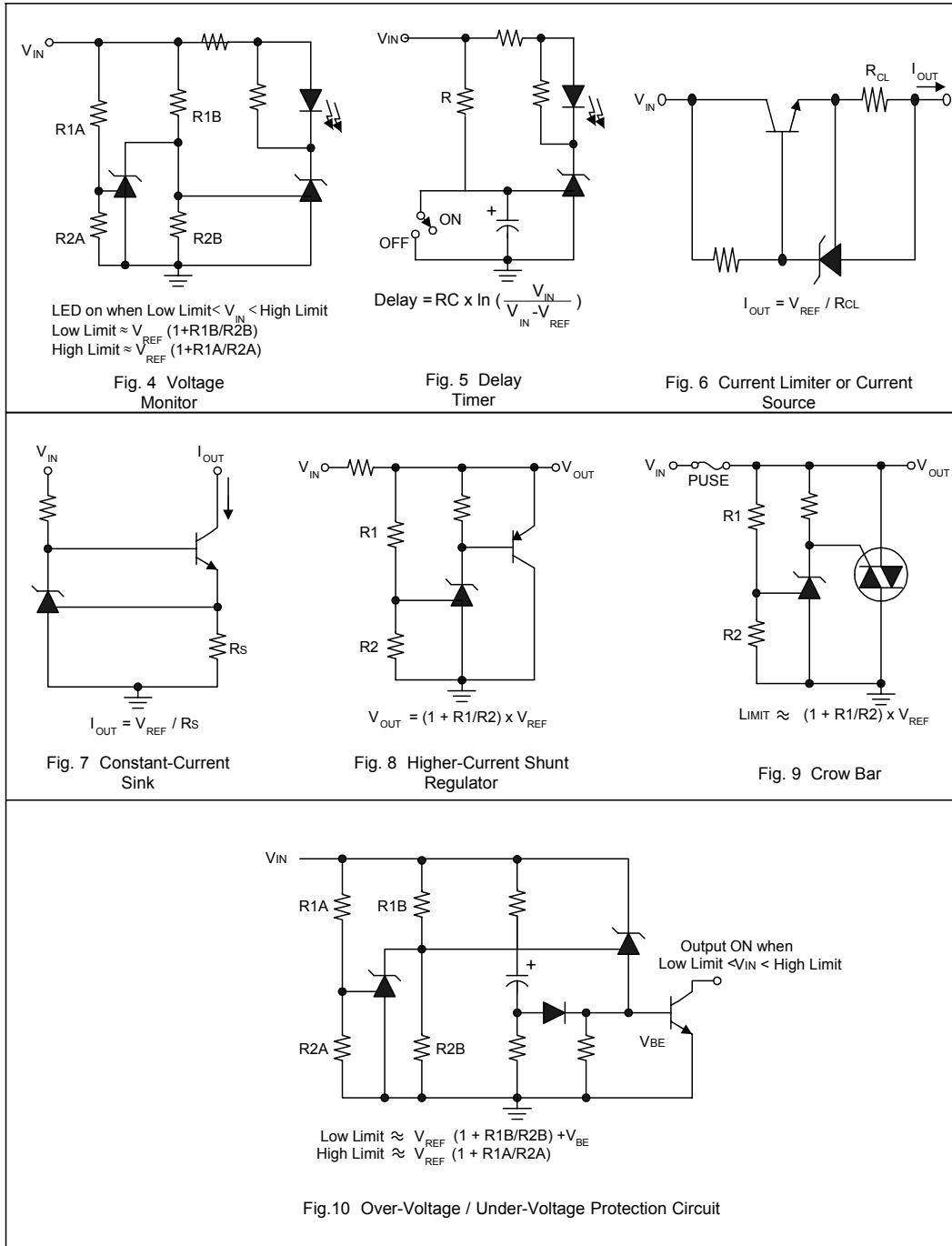

Marking Information

(1) SOT23(R)/SOT25/SC59

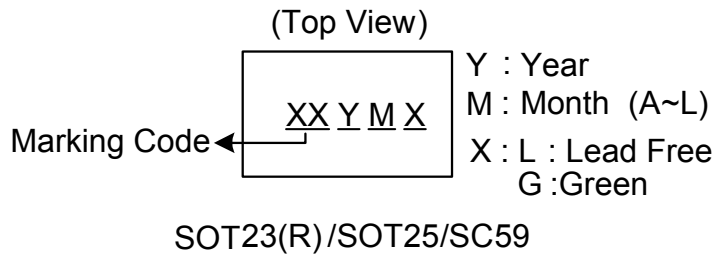

(2) SOP-8L

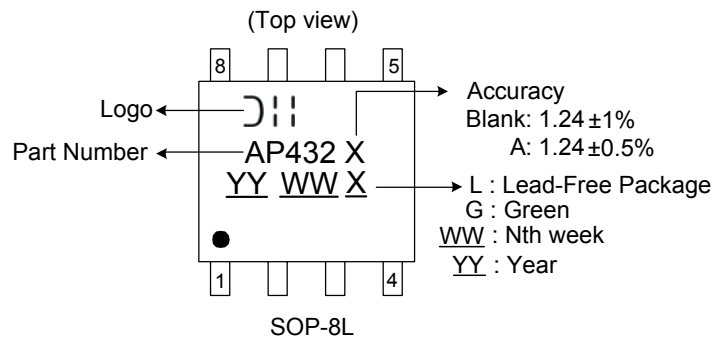

(3) TO92-3

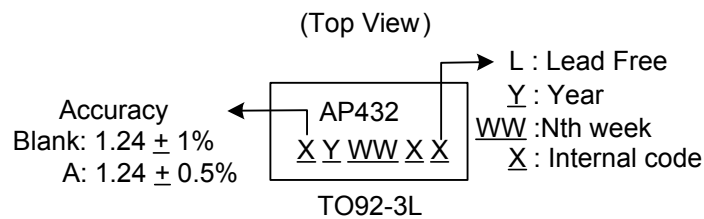

Marking Information (Continued)**Marking Code Table**

Device	Package (Note 10)	Marking Code	Date Code
AP432SA	SOT23	D3	YM
AP432ASA	SOT23	D4	YM
AP432SR	SOT23R	D7	YM
AP432ASR	SOT23R	D8	YM
AP432Q	SOT25	B7	YM
AP432AQ	SOT25	B8	YM
AP432W	SC59	B3	YM
AP432AW	SC59	B4	YM
AP432R	SC59	B5	YM
AP432AR	SC59	B6	YM

Note: 10. For Packaging Details, go to our website at <http://www.diodes.com/datasheets/ap02007.pdf>.

Package Information (All Dimensions in mm)

(1) SOT25

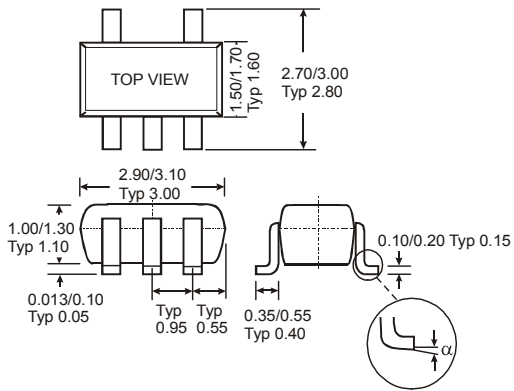

(2) SC59

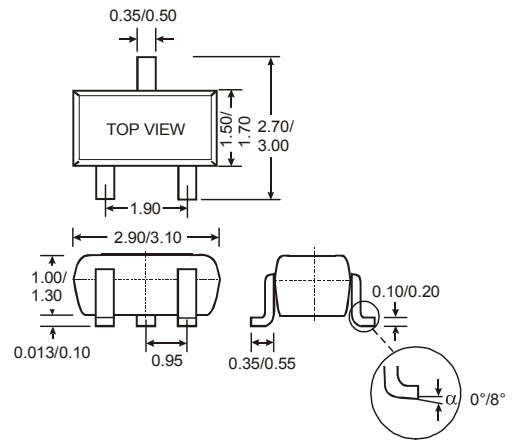

(3) SOT23(R)

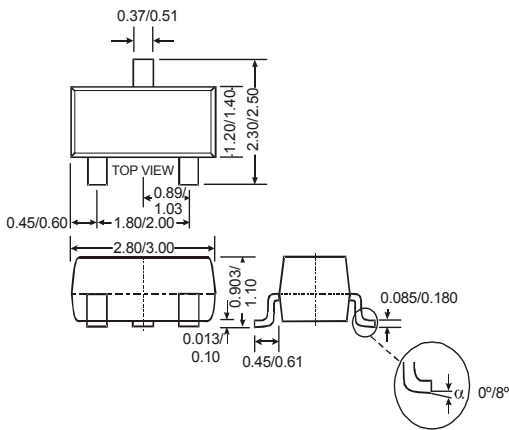

(4) SOP-8L

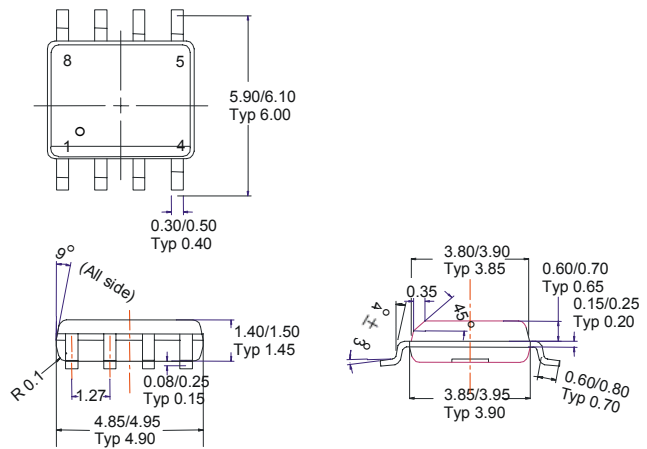

Package Information (Continued) (All Dimensions in mm)

(5) TO92-3L for Ammo pack

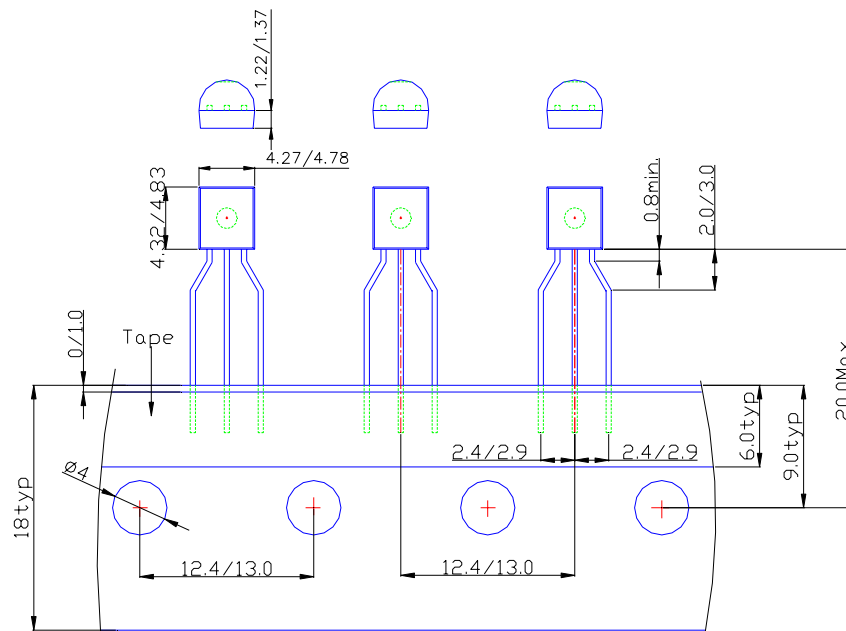

IMPORTANT NOTICE

Diodes Incorporated and its subsidiaries reserve the right to make modifications, enhancements, improvements, corrections or other changes without further notice to any product herein. Diodes Incorporated does not assume any liability arising out of the application or use of any product described herein; neither does it convey any license under its patent rights, nor the rights of others. The user of products in such applications shall assume all risks of such use and will agree to hold Diodes Incorporated and all the companies whose products are represented on our website, harmless against all damages.

LIFE SUPPORT

Diodes Incorporated products are not authorized for use as critical components in life support devices or systems without the expressed written approval of the President of Diodes Incorporated.



Компания «ЭлектроПласт» предлагает заключение долгосрочных отношений при поставках импортных электронных компонентов на взаимовыгодных условиях!

Наши преимущества:

- Оперативные поставки широкого спектра электронных компонентов отечественного и импортного производства напрямую от производителей и с крупнейших мировых складов;
- Поставка более 17-ти миллионов наименований электронных компонентов;
- Поставка сложных, дефицитных, либо снятых с производства позиций;
- Оперативные сроки поставки под заказ (от 5 рабочих дней);
- Экспресс доставка в любую точку России;
- Техническая поддержка проекта, помощь в подборе аналогов, поставка прототипов;
- Система менеджмента качества сертифицирована по Международному стандарту ISO 9001;
- Лицензия ФСБ на осуществление работ с использованием сведений, составляющих государственную тайну;
- Поставка специализированных компонентов (Xilinx, Altera, Analog Devices, Intersil, Interpoint, Microsemi, Aeroflex, Peregrine, Syfer, Eurofarad, Texas Instrument, Miteq, Cobham, E2V, MA-COM, Hittite, Mini-Circuits, General Dynamics и др.);

Помимо этого, одним из направлений компании «ЭлектроПласт» является направление «Источники питания». Мы предлагаем Вам помощь Конструкторского отдела:

- Подбор оптимального решения, техническое обоснование при выборе компонента;
- Подбор аналогов;
- Консультации по применению компонента;
- Поставка образцов и прототипов;
- Техническая поддержка проекта;
- Защита от снятия компонента с производства.



Как с нами связаться

Телефон: 8 (812) 309 58 32 (многоканальный)

Факс: 8 (812) 320-02-42

Электронная почта: org@eplast1.ru

Адрес: 198099, г. Санкт-Петербург, ул. Калинина, дом 2, корпус 4, литера А.