

1.8 V to 5.5 V, 4 Ω Dual SPST Switches

DESCRIPTION

The DG721, DG722 and DG723 are precision dual SPST switches designed to operate from single 1.8 V to 5.5 V power supply with low power dissipation. The DG721, DG722 and DG723 can switch both analog and digital signals within the power supply rail, and conduct well in both directions.

Fabricated with advance submicron CMOS process, these switches provide high precision low and flat ON resistance, low leakage current, low parasitic capacitance, and low charge injection.

The DG721, DG722 and DG723 contain two independent Single Pole Single Throw (SPST) switches. Switch-1 and switch-2 are normally open for the DG721 and normally closed for the DG722. For the DG723, switch-1 is normally open and switch-2 is normally closed with a Break-Before-Make switching timing.

The DG721, DG722 and DG723 are the ideal switches for use in low voltage instruments and healthcare devices, fitting the circuits of low voltage ADC and DAC, analog front end gain control, and signal path control.

As a committed partner to the community and the environment, Vishay Siliconix manufactures this product with lead (Pb)-free device termination. The TDFN8 package has a nickel-palladium-gold device termination and is represented by the lead (Pb)-free “-E4” suffix to the ordering part number. The MSOP-8 package has tin device termination and is represented by “-E3”. Both device terminations meet all JEDEC standards for reflow and MSL rating.

As a further sign of Vishay Siliconix's commitment, the DG721, DG722 and D723 are fully RoHS compliant and Halogen-free.

FEATURES

- **Halogen-free According to IEC 61249-2-21 Definition**
- 1.8 V to 5.5 V single power supply
- Low and flat switch on resistance, 2.5 Ω/typ.
- Low leakage and parasitic capacitance
- 366 MHz, - 3 dB bandwidth
- Latch-up current > 300 mA (JESD78)
- Space saving packages
2 mm x 2 mm TDFN8
MSOP8
- Over voltage tolerant TTL/CMOS compatible
- **Compliant to RoHS Directive 2002/95/EC**



RoHS
COMPLIANT
HALOGEN
FREE

APPLICATIONS

- Healthcare and medical devices
- Test instruments
- Portable meters
- Data acquisitions
- Control and automation
- PDAs and modems
- Communication systems
- Audio, video systems
- Mechanical reed relay replacement

FUNCTIONAL BLOCK DIAGRAM AND PIN CONFIGURATION

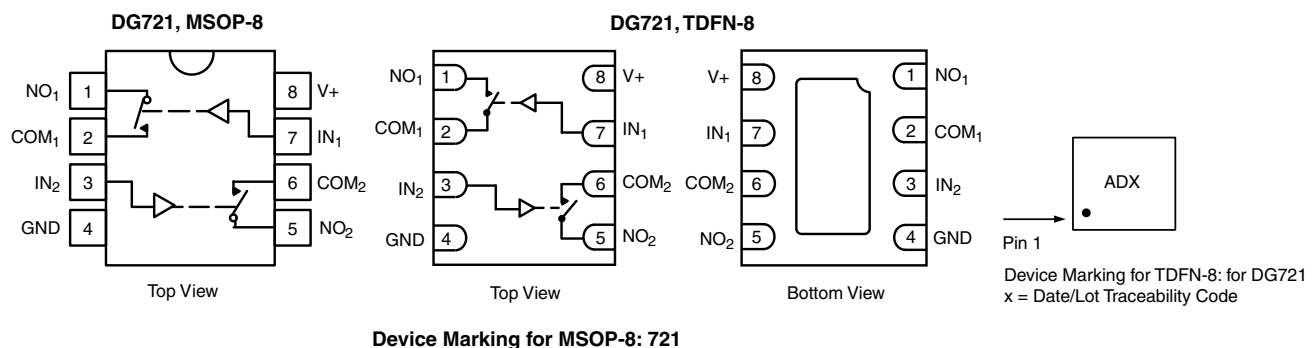

DG721, DG722, DG723

Vishay Siliconix

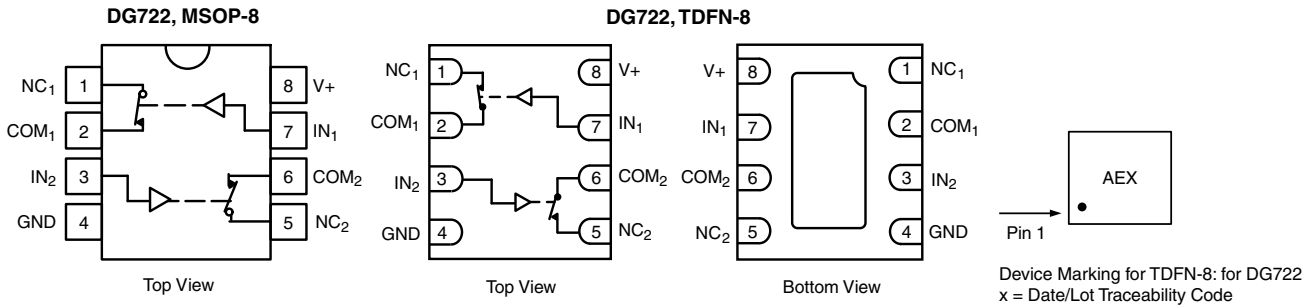

Device Marking for MSOP-8: 722

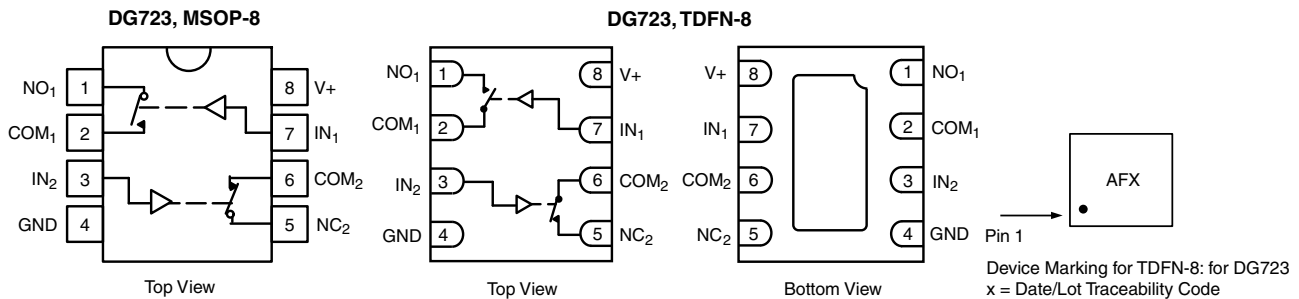

Device Marking for MSOP-8: 723

| TRUTH TABLE (DG721, DG722) | | | |
|----------------------------|-------|-------|----------|
| Logic | DG721 | DG722 | Switches |
| 0 | 0 | 1 | Off |
| 1 | 1 | 0 | On |

| TRUTH TABLE (DG723) | | |
|---------------------|----------|----------|
| Logic | Switch-1 | Switch-2 |
| 0 | Off | On |
| 1 | On | Off |

| ORDERING INFORMATION | | |
|----------------------|---------|----------------|
| Temperature Range | Package | Part Number |
| - 40 °C to 85 °C | MSOP-8 | DG721DQ-T1-GE3 |
| | | DG722DQ-T1-GE3 |
| | | DG723DQ-T1-GE3 |
| | TDFN-8 | DG721DN-T1-GE4 |
| | | DG722DN-T1-GE4 |
| | | DG723DN-T1-GE4 |

| ABSOLUTE MAXIMUM RATINGS | | | |
|--|---------------------|---------------------|------|
| Parameter | | Limit | Unit |
| Referenced V+ to GND | | - 0.3 to 6 | V |
| IN, COM, NC, NO ^a | | - 0.3 to (V+ + 0.3) | |
| Continuous Current (Any Terminal) | | ± 50 | mA |
| Peak Current (Pulsed at 1 ms, 10 % duty cycle) | | ± 200 | |
| Storage Temperature (D Suffix) | | - 65 to 150 | °C |
| Power Dissipation (Packages) ^b | MSOP-8 ^c | 320 | mW |
| | TDFN-8 ^d | 842 | |

- Notes:
- Signals on NC, NO, or COM or IN exceeding V+ will be clamped by internal diodes. Limit forward diode current to maximum current ratings.
 - All leads welded or soldered to PC board.
 - Derate 4 mW/°C above 70 °C.
 - Derate 10.53 mW/°C above 70 °C.



| SPECIFICATIONS (V+ = 3 V) | | | | | | | |
|---------------------------------------|---|---|--------------------|----------------------------|-------------------|-------------------|------|
| Parameter | Symbol | Test Conditions Otherwise Unless Specified V+ = 3 V, ± 10 %, VIN = 0.4 or 1.5 V ^e | Temp. ^a | Limits - 40 °C to 85 °C | | | Unit |
| | | | | Min. ^b | Typ. ^c | Max. ^b | |
| Analog Switch | | | | | | | |
| Analog Signal Range ^d | V _{NO} , V _{NC} V _{COM} | | Full | 0 | | V+ | V |
| On-Resistance | R _{ON} | V+ = 2.7 V, V _{COM} = 0 V to V+, I _{NO} , I _{NC} = - 10 mA | Room Full | | 6.5 | 10 | Ω |
| R _{ON} Flatness ^d | R _{ON} Flatness | V+ = 2.7 V, V _{COM} = 1.1 V to 1.6 V, I _{NO} , I _{NC} = - 10 mA | Room | | 0.4 | | |
| R _{ON} Match ^d | R _{ON} Match | V+ = 2.7 V, V _D = 1.1 V to 1.6 V, I _D = - 10 mA | Room Full | | 0.3 | 0.9 | |
| Switch Off Leakage Current | I _{NO(off)} I _{NC(off)} | V+ = 3.3 V V _{NO} , V _{NC} = 1 V/3 V, V _{COM} = 3 V/1 V | Room Full | - 0.25 - 0.35 | | 0.25 0.35 | nA |
| | I _{COM(off)} | | Room Full | - 0.25 - 0.35 | | 0.25 0.35 | |
| Channel-On Leakage Current | I _{COM(on)} | V+ = 3.3 V, V _{NO} , V _{NC} = V _{COM} = 1 V/3 V | Room Full | - 0.25 - 0.35 | | 0.25 0.35 | |
| Digital Control | | | | | | | |
| Input High Voltage | V _{INH} | | Full | 2 | | | V |
| Input Low Voltage | V _{INL} | | Full | | | 0.4 | |
| Input Capacitance ^d | C _{in} | f = 1 MHz | Full | | 2.4 | | pF |
| Input Current | I _{INL} or I _{INH} | V _{IN} = 0 or V+ | Full | - 1 | | 1 | μA |
| Dynamic Characteristics | | | | | | | |
| Turn-On Time | t _{ON} | V _{NO} or V _{NC} = 2 V, R _L = 300 Ω, C _L = 35 pF figures 1 and 2 | Room Full | | 16 | 55 | ns |
| Turn-Off Time | t _{OFF} | | Room Full | | 7 | 40 | |
| Charge Injection ^d | Q _{INJ} | C _L = 1 nF, V _{GEN} = 0 V, R _{GEN} = 0 Ω, figure 3 | Room | | 1.8 | | pC |
| Bandwidth ^d | BW | V+ = 3 V, R _L = 50 Ω, C _L = 5 pF, - 3dB | Room | | 319 | | MHz |
| Off-Isolation ^d | OIRR | R _L = 50 Ω, C _L = 5 pF, f = 1 MHz | Room | | - 67 | | dB |
| Crosstalk ^d | X _{TALK} | | Room | | - 92 | | |
| Off-Isolation ^d | OIRR | R _L = 50 Ω, C _L = 5 pF, f = 10 MHz | Room | | - 47 | | |
| Crosstalk ^d | X _{TALK} | | Room | | - 90 | | |
| Source-Off Capacitance ^d | C _{NC/NO(off)} | V _{IN} = 0 or V+, f = 1 MHz | Room | | 8 | | pF |
| Drain-Off Capacitance ^d | C _{COM(off)} | | Room | | 9 | | |
| Channel-On Capacitance ^d | C _{ON} | | Room | | 22 | | |
| Power Supply | | | | | | | |
| Power Supply Current | I+ | V _{IN} = 0 or V+, V+ = 3.3 V | | | | 1 | μA |

| SPECIFICATIONS (V+ = 5 V) | | | | | | | |
|---------------------------------------|---|--|--------------------|----------------------------|-------------------|-------------------|------|
| Parameter | Symbol | Test Conditions Otherwise Unless Specified V+ = 5 V, ± 10 %, V _{IN} = 0.8 or 2.4 V ^e | Temp. ^a | Limits - 40 °C to 85 °C | | | Unit |
| | | | | Min. ^b | Typ. ^c | Max. ^b | |
| Analog Switch | | | | | | | |
| Analog Signal Range ^d | V _{NO} , V _{NC} V _{COM} | | Full | 0 | | V+ | V |
| On-Resistance | R _{ON} | V+ = 4.5 V, V _{COM} = 0 V to V+, I _{NO} , I _{NC} = 10 mA | Room Full | | 2.5 | 4.5 5 | Ω |
| R _{ON} Flatness ^d | R _{ON} Flatness | V+ = 4.5 V, V _{COM} = 1.3 V to 3 V, I _{NO} , I _{NC} = 10 mA | Room | | 0.75 | 1.5 | |
| R _{ON} Match ^d | R _{ON} Match | V+ = 4.5 V, I _D = 10 mA, V _{COM} = 1.3 V to 3 V | Room | | 0.2 | 0.9 | |
| Switch Off Leakage Current | I _{NO(off)} I _{NC(off)} | V+ = 5.5 V V _{NO} , V _{NC} = 1 V/4.5 V, V _{COM} = 4.5 V/1 V | Room Full | - 0.25 - 0.35 | | 0.25 0.35 | nA |
| | I _{COM(off)} | | Room Full | - 0.25 - 0.35 | | 0.25 0.35 | |
| Channel-On Leakage Current | I _{COM(on)} | V+ = 5.5 V V _{NO} , V _{NC} = V _{COM} = 1 V/4.5 V | Room Full | - 0.25 - 0.35 | | 0.25 0.35 | |
| Digital Control | | | | | | | |
| Input High Voltage | V _{INH} | | Full | 2.4 | | | V |
| Input Low Voltage | V _{INL} | | Full | | | 0.8 | |
| Input Capacitance | C _{in} | f = 1 MHz | Full | | 2.2 | | pF |
| Input Current | I _{INL} or I _{INH} | V _{IN} = 0 or V+ | Full | - 0.1 | 0.005 | 0.1 | μA |
| Dynamic Characteristics | | | | | | | |
| Turn-On Time ^d | t _{ON} | V _{NO} or V _{NC} = 3 V, R _L = 300 Ω, C _L = 35 pF figures 1 and 2 | Room Full | | 17 | 30 40 | ns |
| Turn-Off Time ^d | t _{OFF} | | Room Full | | 9 | 35 | |
| Charge Injection ^d | Q _{INJ} | C _L = 1 nF, V _{GEN} = 0 V, R _{GEN} = 0 Ω, figure 3 | Room | | 2.2 | | pC |
| Bandwidth ^d | BW | V+ = 5 V, R _L = 50 Ω, C _L = 5 pF, - 3 dB | Room | | 366 | | MHz |
| Off-Isolation ^d | OIRR | R _L = 50 Ω, C _L = 5 pF, f = 1 MHz | Room | | - 67 | | dB |
| Crosstalk ^d | X _{TALK} | | Room | | - 90 | | |
| Off-Isolation ^d | OIRR | R _L = 50 Ω, C _L = 5 pF, f = 10 MHz | Room | | - 47 | | dB |
| Crosstalk ^d | X _{TALK} | | Room | | - 90 | | |
| Source-Off Capacitance ^d | C _{NC/NO(off)} | V _{IN} = 0 or V+, f = 1 MHz | Room | | 8 | | pF |
| Drain-Off Capacitance ^d | C _{COM(off)} | | Room | | 9 | | |
| Channel-On Capacitance ^d | C _{ON} | | Room | | 22 | | |
| Power Supply | | | | | | | |
| Power Supply Range | V+ | | | 2.6 | | 4.3 | V |
| Power Supply Current | I+ | V _{IN} = 0 or V+, V+ = 5.5 V | Full | | | 2 | μA |

Notes:

- Room = 25 °C, Full = as determined by the operating suffix.
- The algebraic convention whereby the most negative value is a minimum and the most positive a maximum, is used in this data sheet.
- Typical values are for design aid only, not guaranteed nor subject to production testing.
- Guarantee by design, nor subjected to production test.
- V_{IN} = input voltage to perform proper function.
- Not production tested.

Stresses beyond those listed under "Absolute Maximum Ratings" may cause permanent damage to the device. These are stress ratings only, and functional operation of the device at these or any other conditions beyond those indicated in the operational sections of the specifications is not implied. Exposure to absolute maximum rating conditions for extended periods may affect device reliability.

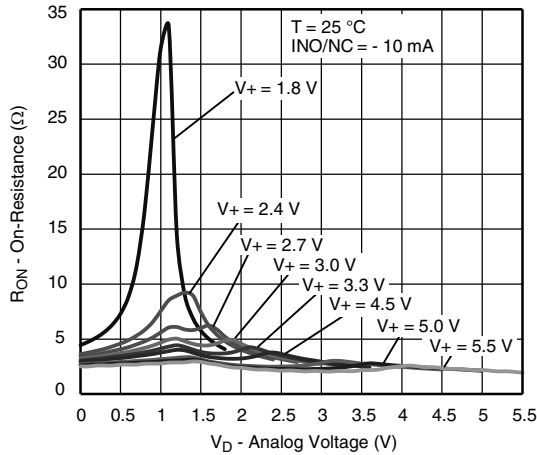
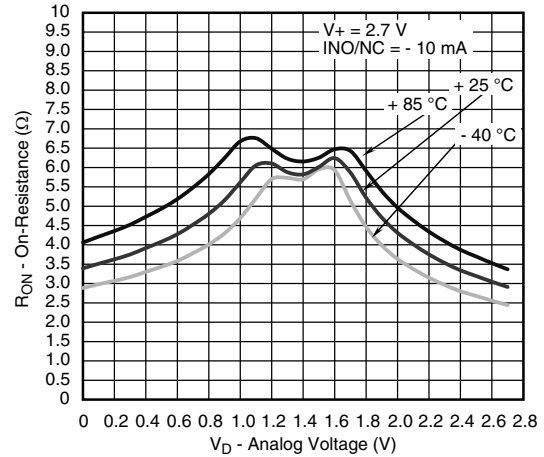
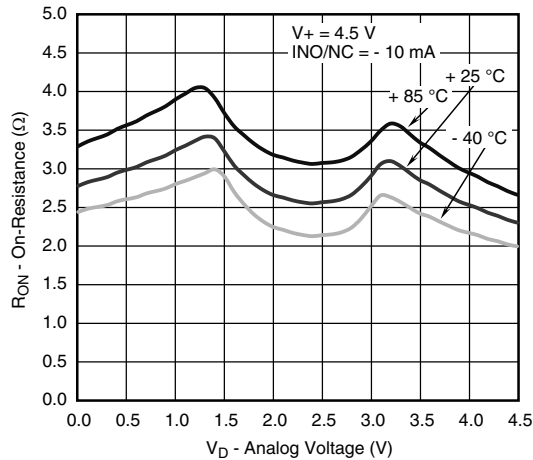
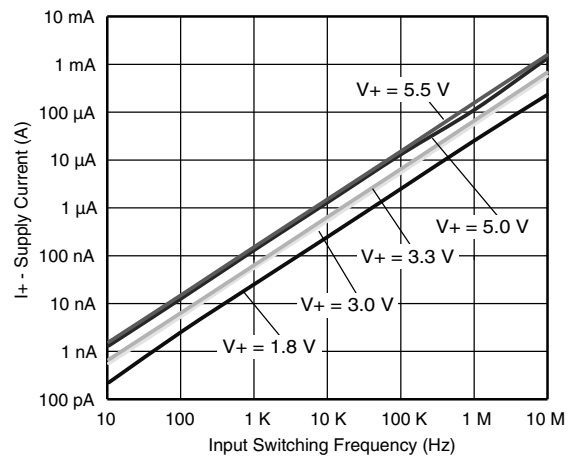
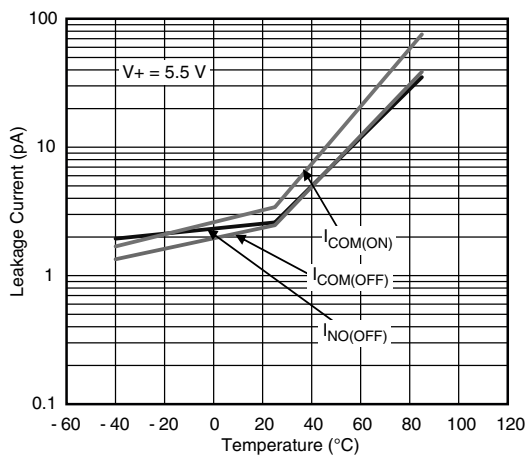
TYPICAL CHARACTERISTICS ($T_A = 25\text{ }^\circ\text{C}$, unless otherwise noted)

 R_{ON} vs. V_D and Single Supply Voltage

 R_{ON} vs. Analog Voltage and Temperature

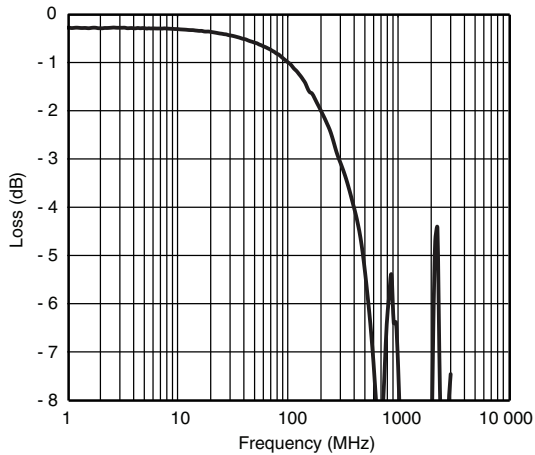
 R_{ON} vs. Analog Voltage and Temperature

Supply Current vs. Input Switching Frequency

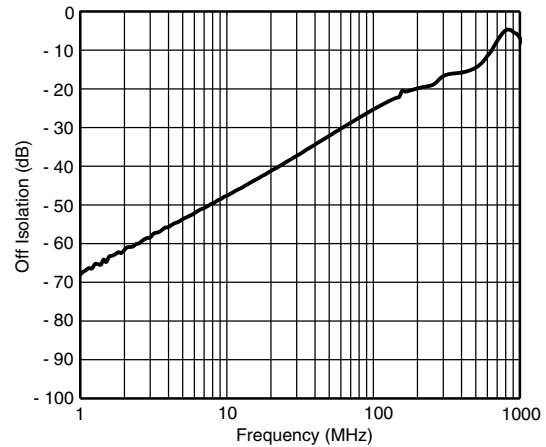
Leakage Current vs. Temperature

Switching Threshold vs. Supply Voltage

TYPICAL CHARACTERISTICS (T_A = 25 °C, unless otherwise noted)



Insertion Loss vs. Frequency



Off Isolation vs. Frequency

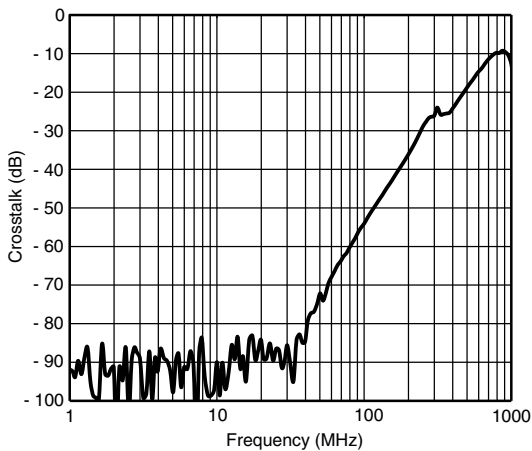

Crosstalk vs. Frequency

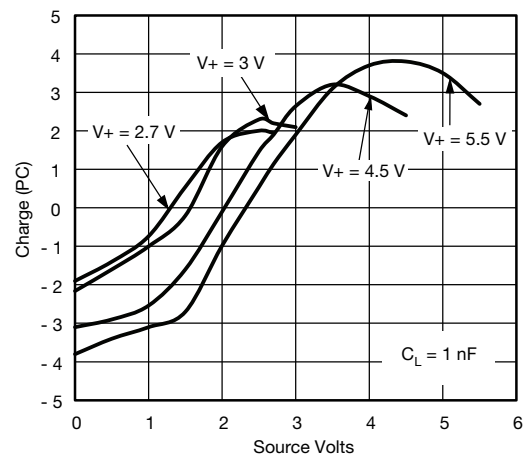

Charge Injection vs. Analog Voltage

TEST CIRCUITS

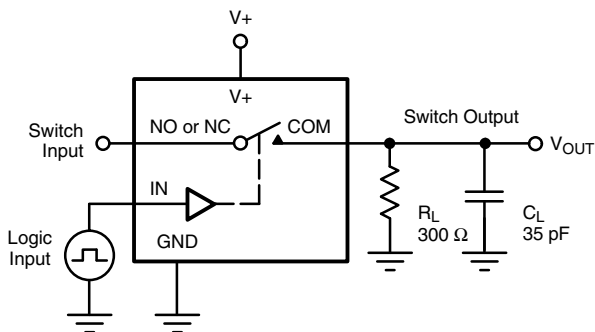

$$V_{OUT} = V_{COM} \left(\frac{R_L}{R_L + R_{ON}} \right)$$

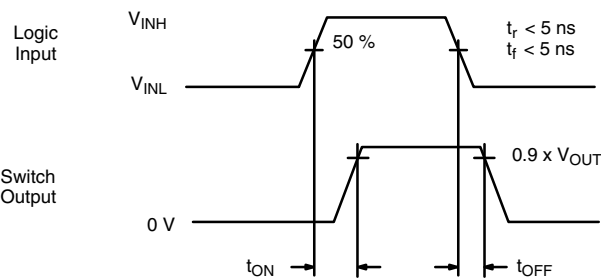

Logic "1" = Switch On
Logic input waveforms inverted for switches that have the opposite logic sense.

Figure 1. Switching Time

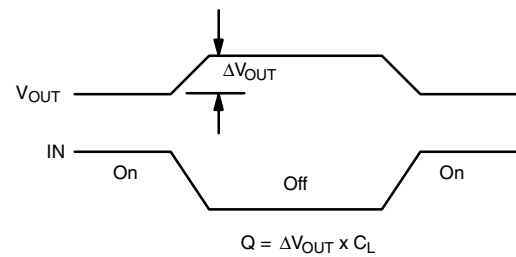
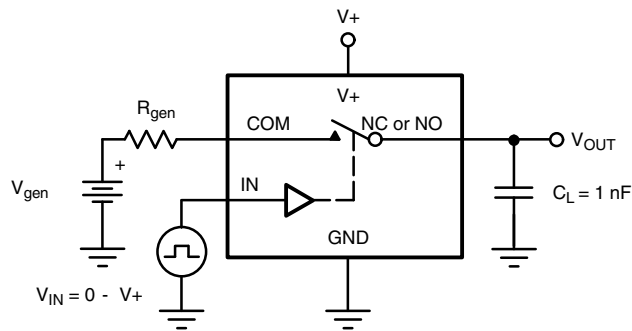
TEST CIRCUITS

IN depends on switch configuration: input polarity determined by sense of switch.

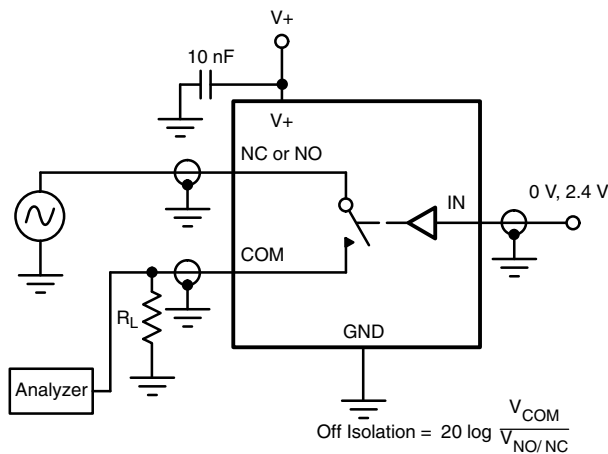
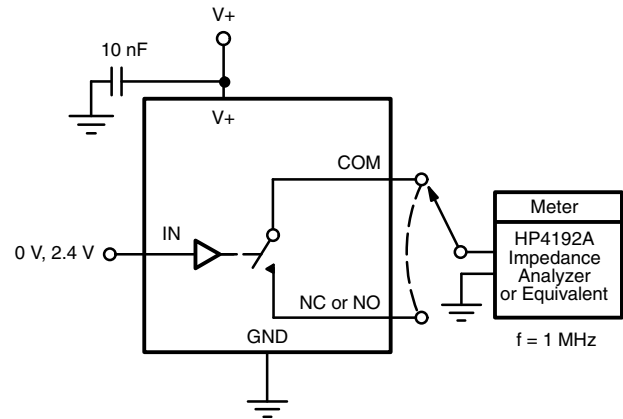
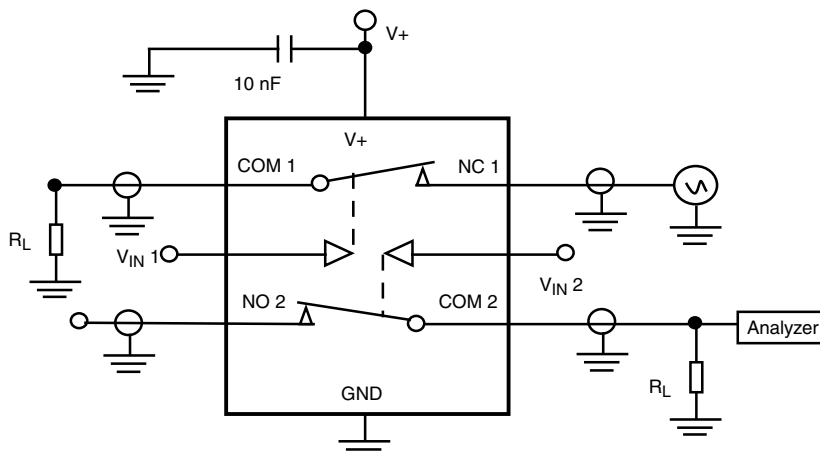
Figure 2. Charge Injection

Figure 3. Off-Isolation

Figure 4. Channel Off/On Capacitance

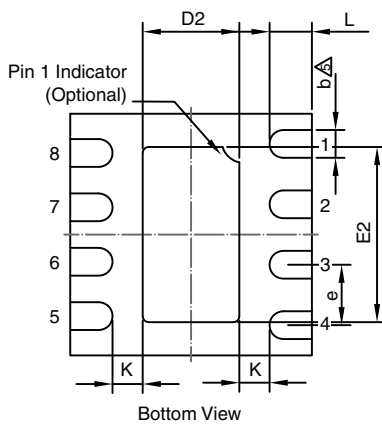
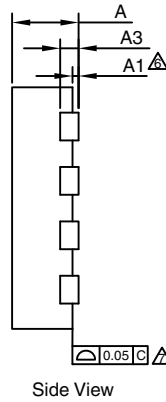
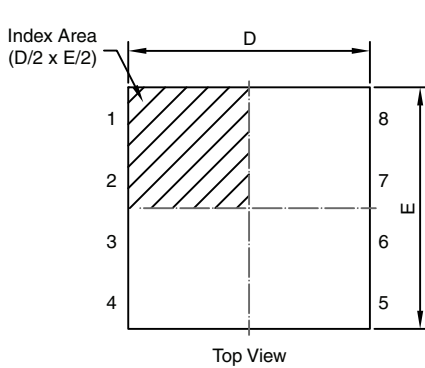
Figure 5. Channel to Channel Crosstalk

Vishay Siliconix maintains worldwide manufacturing capability. Products may be manufactured at one of several qualified locations. Reliability data for Silicon Technology and Package Reliability represent a composite of all qualified locations. For related documents such as package/tape drawings, part marking, and reliability data, see www.vishay.com/ppg?66586.

CASE OUTLINE FOR TDFN8 2 x 2



| DIM. | MILLIMETERS | | | INCHES | | |
|------|-------------|------|------|-----------|-------|-------|
| | MIN. | NOM. | MAX. | MIN. | NOM. | MAX. |
| A | 0.50 | 0.55 | 0.60 | 0.020 | 0.022 | 0.024 |
| A1 | 0.00 | - | 0.05 | 0.000 | - | 0.002 |
| A3 | 0.152 REF | | | 0.006 REF | | |
| b | 0.18 | 0.23 | 0.28 | 0.007 | 0.009 | 0.011 |
| D | 1.95 | 2.00 | 2.05 | 0.077 | 0.079 | 0.081 |
| D2 | 0.75 | 0.80 | 0.85 | 0.030 | 0.031 | 0.033 |
| e | 0.50 BSC | | | 0.020 BSC | | |
| E | 1.95 | 2.00 | 2.05 | 0.077 | 0.079 | 0.081 |
| E2 | 1.40 | 1.45 | 1.50 | 0.055 | 0.057 | 0.059 |
| K | - | 0.20 | - | - | 0.008 | - |
| L | 0.30 | 0.35 | 0.40 | 0.012 | 0.014 | 0.016 |

ECN: C11-0033 Rev. A, 07-Feb-11
DWG: 5997

Note

- All dimensions are in millimeters which will govern.
 - Max. package warpage is 0.05 mm.
 - Max. allowable burrs is 0.076 mm in all directions.
 - Pin #1 ID on top will be laser/ink marked.
- $\triangle 5$ Dimension applies to metallized terminal and is measured between 0.20 mm and 0.25 mm from terminal tip.
 $\triangle 6$ Applied only for terminals.
 $\triangle 7$ Applied for exposed pad and terminals.



MSOP: 8-LEADS

JEDEC Part Number: MO-187, (Variation AA and BA)



NOTES:

1. Die thickness allowable is 0.203 ± 0.0127 .
2. Dimensioning and tolerances per ANSI.Y14.5M-1994.
3. Dimensions "D" and "E₁" do not include mold flash or protrusions, and are measured at Datum plane [-H-], mold flash or protrusions shall not exceed 0.15 mm per side.
4. Dimension is the length of terminal for soldering to a substrate.
5. Terminal positions are shown for reference only.
6. Formed leads shall be planar with respect to one another within 0.10 mm at seating plane.
7. The lead width dimension does not include Dambar protrusion. Allowable Dambar protrusion shall be 0.08 mm total in excess of the lead width dimension at maximum material condition. Dambar cannot be located on the lower radius or the lead foot. Minimum space between protrusions and an adjacent lead to be 0.14 mm. See detail "B" and Section "C-C".
8. Section "C-C" to be determined at 0.10 mm to 0.25 mm from the lead tip.
9. Controlling dimension: millimeters.
10. This part is compliant with JEDEC registration MO-187, variation AA and BA.
11. Datums [-A-] and [-B-] to be determined Datum plane [-H-].
12. Exposed pad area in bottom side is the same as teh leadframe pad size.

N = 8L

| Dim | MILLIMETERS | | | Note |
|----------------------|-------------|------|------|------|
| | Min | Nom | Max | |
| A | - | - | 1.10 | |
| A₁ | 0.05 | 0.10 | 0.15 | |
| A₂ | 0.75 | 0.85 | 0.95 | |
| b | 0.25 | - | 0.38 | 8 |
| b₁ | 0.25 | 0.30 | 0.33 | 8 |
| c | 0.13 | - | 0.23 | |
| c₁ | 0.13 | 0.15 | 0.18 | |
| D | 3.00 BSC | | | 3 |
| E | 4.90 BSC | | | |
| E₁ | 2.90 | 3.00 | 3.10 | 3 |
| e | 0.65 BSC | | | |
| e₁ | 1.95 BSC | | | |
| L | 0.40 | 0.55 | 0.70 | 4 |
| N | 8 | | | 5 |
| α | 0° | 4° | 6° | |

ECN: T-02080—Rev. C, 15-Jul-02
 DWG: 5867



Disclaimer

ALL PRODUCT, PRODUCT SPECIFICATIONS AND DATA ARE SUBJECT TO CHANGE WITHOUT NOTICE TO IMPROVE RELIABILITY, FUNCTION OR DESIGN OR OTHERWISE.

Vishay Intertechnology, Inc., its affiliates, agents, and employees, and all persons acting on its or their behalf (collectively, "Vishay"), disclaim any and all liability for any errors, inaccuracies or incompleteness contained in any datasheet or in any other disclosure relating to any product.

Vishay makes no warranty, representation or guarantee regarding the suitability of the products for any particular purpose or the continuing production of any product. To the maximum extent permitted by applicable law, Vishay disclaims (i) any and all liability arising out of the application or use of any product, (ii) any and all liability, including without limitation special, consequential or incidental damages, and (iii) any and all implied warranties, including warranties of fitness for particular purpose, non-infringement and merchantability.

Statements regarding the suitability of products for certain types of applications are based on Vishay's knowledge of typical requirements that are often placed on Vishay products in generic applications. Such statements are not binding statements about the suitability of products for a particular application. It is the customer's responsibility to validate that a particular product with the properties described in the product specification is suitable for use in a particular application. Parameters provided in datasheets and/or specifications may vary in different applications and performance may vary over time. All operating parameters, including typical parameters, must be validated for each customer application by the customer's technical experts. Product specifications do not expand or otherwise modify Vishay's terms and conditions of purchase, including but not limited to the warranty expressed therein.

Except as expressly indicated in writing, Vishay products are not designed for use in medical, life-saving, or life-sustaining applications or for any other application in which the failure of the Vishay product could result in personal injury or death. Customers using or selling Vishay products not expressly indicated for use in such applications do so at their own risk and agree to fully indemnify and hold Vishay and its distributors harmless from and against any and all claims, liabilities, expenses and damages arising or resulting in connection with such use or sale, including attorneys fees, even if such claim alleges that Vishay or its distributor was negligent regarding the design or manufacture of the part. Please contact authorized Vishay personnel to obtain written terms and conditions regarding products designed for such applications.

No license, express or implied, by estoppel or otherwise, to any intellectual property rights is granted by this document or by any conduct of Vishay. Product names and markings noted herein may be trademarks of their respective owners.



Компания «ЭлектроПласт» предлагает заключение долгосрочных отношений при поставках импортных электронных компонентов на взаимовыгодных условиях!

Наши преимущества:

- Оперативные поставки широкого спектра электронных компонентов отечественного и импортного производства напрямую от производителей и с крупнейших мировых складов;
- Поставка более 17-ти миллионов наименований электронных компонентов;
- Поставка сложных, дефицитных, либо снятых с производства позиций;
- Оперативные сроки поставки под заказ (от 5 рабочих дней);
- Экспресс доставка в любую точку России;
- Техническая поддержка проекта, помощь в подборе аналогов, поставка прототипов;
- Система менеджмента качества сертифицирована по Международному стандарту ISO 9001;
- Лицензия ФСБ на осуществление работ с использованием сведений, составляющих государственную тайну;
- Поставка специализированных компонентов (Xilinx, Altera, Analog Devices, Intersil, Interpoint, Microsemi, Aeroflex, Peregrine, Syfer, Eurofarad, Texas Instrument, Miteq, Cobham, E2V, MA-COM, Hittite, Mini-Circuits, General Dynamics и др.);

Помимо этого, одним из направлений компании «ЭлектроПласт» является направление «Источники питания». Мы предлагаем Вам помощь Конструкторского отдела:

- Подбор оптимального решения, техническое обоснование при выборе компонента;
- Подбор аналогов;
- Консультации по применению компонента;
- Поставка образцов и прототипов;
- Техническая поддержка проекта;
- Защита от снятия компонента с производства.



Как с нами связаться

Телефон: 8 (812) 309 58 32 (многоканальный)

Факс: 8 (812) 320-02-42

Электронная почта: org@eplast1.ru

Адрес: 198099, г. Санкт-Петербург, ул. Калинина, дом 2, корпус 4, литера А.