

## 48 V - 130 W high efficiency converter with PFC for LED street lighting applications based on L6562 and L6599



### Features

- Extended input mains range: 85 to 305 V<sub>AC</sub> - frequency 45 to 55 Hz
- Output voltage: 48 V at 2.7 A
- Long-life: electrolytic capacitors not used
- Mains harmonics in accordance with EN61000-3-2 Class C
- Efficiency at full load greater than 91% at 115 V<sub>AC</sub>
- EMI in accordance with EN55022 Class B; EN55015
- Safety: double insulation, in accordance with EN60950, SELV
- Dimensions: 75 x 135 mm, 30 mm maximum component height
- PCB: single side, 35 μm, FR-4, mixed PTH/SMT
- RoHS compliant
- WEEE compliant

### Description

The STEVAL-ILL053V2 evaluation board implements a 130 W LED power supply for street lighting.

The circuit is composed of two stages: a front-end PFC using the L6562AT, and an LLC resonant converter based on the L6599AT.

The strengths of this design are its very high efficiency; wide input mains range (85-305 V<sub>AC</sub>) operation and long-term reliability.

Because mean time between failures (MTBF) in power supplies is typically affected by the high failure rate of common electrolytic capacitors, the STEVAL-ILL053V2 evaluation board offers an innovative design approach using film capacitors from EPCOS in place of electrolytic capacitors.

Thanks to the high efficiency achieved, only a small heatsink for the PFC stage is needed, while the other power components implement surface mount technology (SMT), which significantly lowers costs.

The STEVAL-ILL053V2 evaluation board also provides protection against overload, short-circuit and open-loop in each stage, and overvoltage protection on the input, with auto-restart.

Summary table

48 V - 130 W high efficiency converter with PFC for LED street lighting applications based on L6562 and L6599	STEVAL-ILL053V2
N-channel 600 V, 0.550 Ω typ., 7.5 A MDmesh M2 EP Power MOSFET in a DPAK package	STD11N60M2-EP
N-channel 600 V, 0.175 Ω typ., 18 A MDmesh M2 EP Power MOSFET in a TO-220FP package	STF25N60M2-EP
Transition-mode PFC controller	L6562AT
Improved high-voltage resonant controller	L6599AT

# 1 STEVAL-ILL053V2 featured components

Figure 1. ST components on STEVAL-ILL053V2 board

1. D11 STPS10150CG power schottky rectifier
2. D12 STPS10150CG power schottky rectifier
3. D2 STTH3L06U ultrafast high voltage rectifier
4. D20 STPS1L60A fast switching diode
5. Q2 STF25N60M2-EP N-channel power MOSFET
6. Q4 STD11N60M2-EP N-channel power MOSFET
7. Q5 STD11N60M2-EP N-channel power MOSFET
8. U1 L6562AT tm pfc controller
9. U2 L6599AT improved hv resonant controller
10. U5 TS2431AILT programmable shunt voltage reference

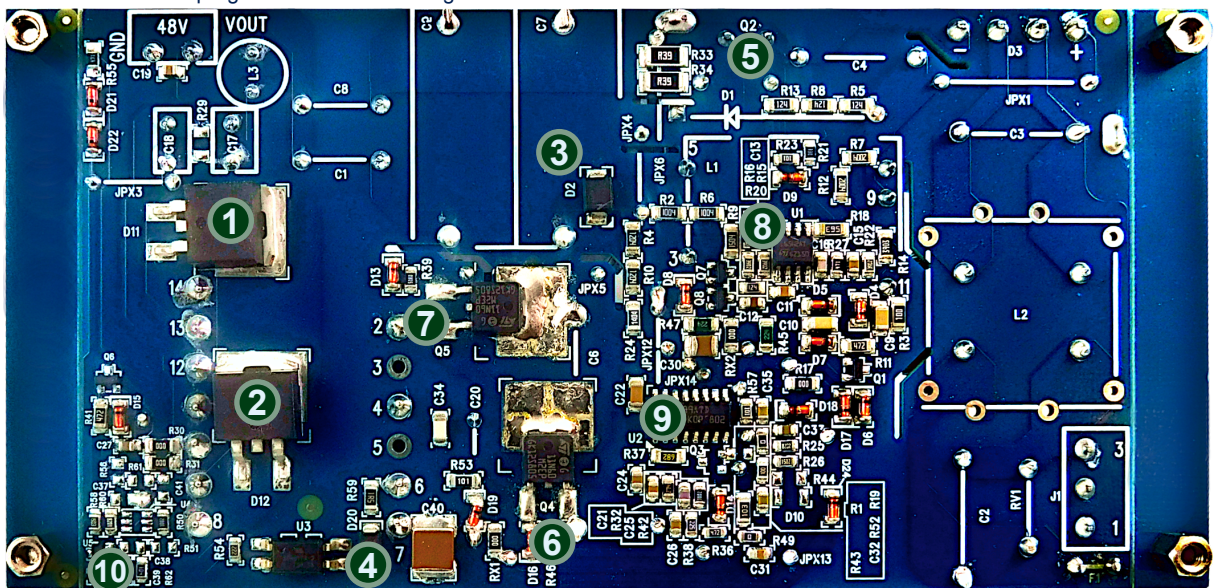

## 2 Schematic diagram

Figure 2. STEVAL-ILL053V2 board schematic

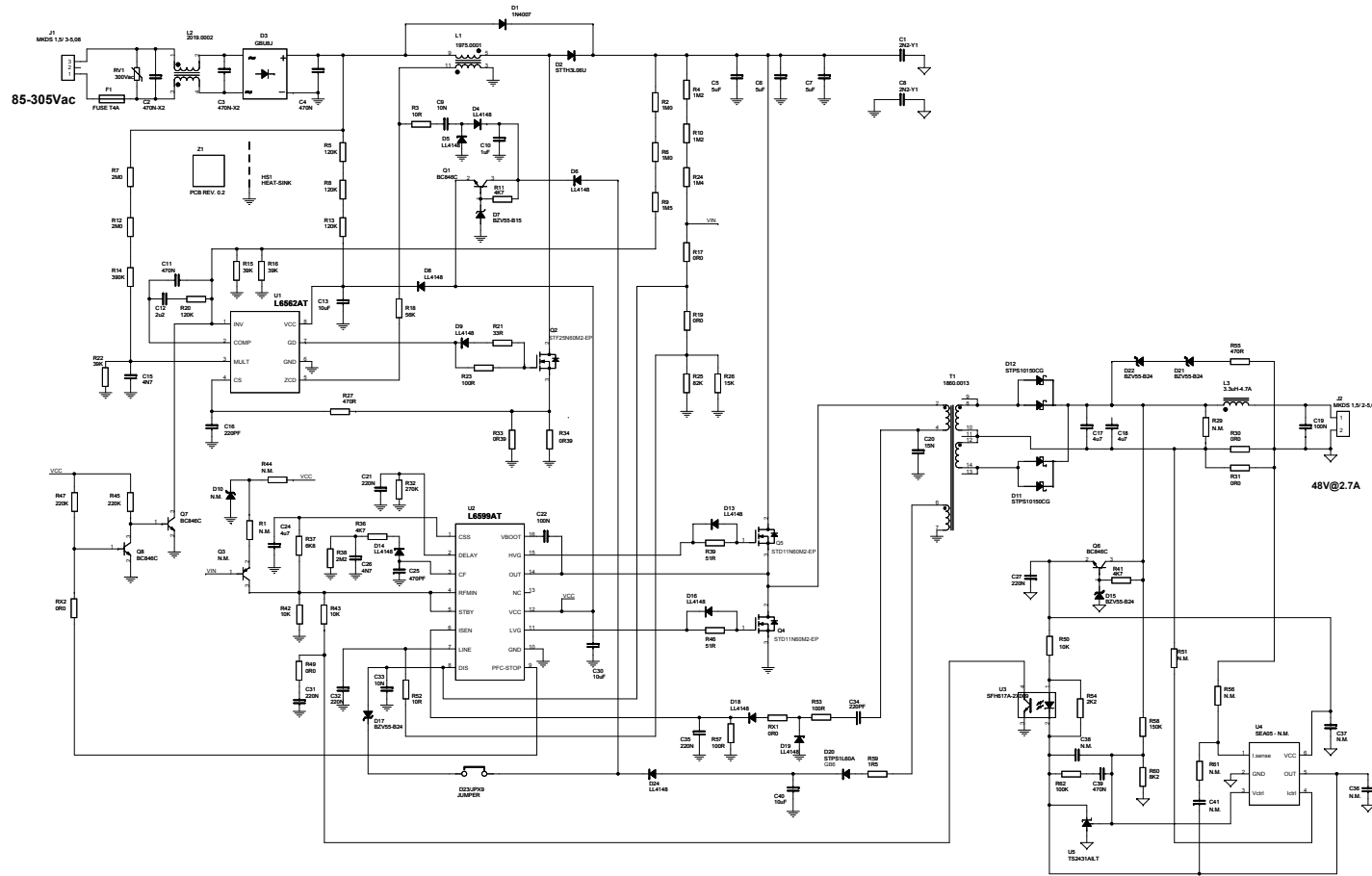

## Revision history

**Table 1. Document revision history**

Date	Version	Changes
07-Dec-2018	1	Initial release.

**IMPORTANT NOTICE – PLEASE READ CAREFULLY**

STMicroelectronics NV and its subsidiaries (“ST”) reserve the right to make changes, corrections, enhancements, modifications, and improvements to ST products and/or to this document at any time without notice. Purchasers should obtain the latest relevant information on ST products before placing orders. ST products are sold pursuant to ST’s terms and conditions of sale in place at the time of order acknowledgement.

Purchasers are solely responsible for the choice, selection, and use of ST products and ST assumes no liability for application assistance or the design of Purchasers’ products.

No license, express or implied, to any intellectual property right is granted by ST herein.

Resale of ST products with provisions different from the information set forth herein shall void any warranty granted by ST for such product.

ST and the ST logo are trademarks of ST. All other product or service names are the property of their respective owners.

Information in this document supersedes and replaces information previously supplied in any prior versions of this document.

© 2018 STMicroelectronics – All rights reserved



Компания «ЭлектроПласт» предлагает заключение долгосрочных отношений при поставках импортных электронных компонентов на взаимовыгодных условиях!

Наши преимущества:

- Оперативные поставки широкого спектра электронных компонентов отечественного и импортного производства напрямую от производителей и с крупнейших мировых складов;
- Поставка более 17-ти миллионов наименований электронных компонентов;
- Поставка сложных, дефицитных, либо снятых с производства позиций;
- Оперативные сроки поставки под заказ (от 5 рабочих дней);
- Экспресс доставка в любую точку России;
- Техническая поддержка проекта, помощь в подборе аналогов, поставка прототипов;
- Система менеджмента качества сертифицирована по Международному стандарту ISO 9001;
- Лицензия ФСБ на осуществление работ с использованием сведений, составляющих государственную тайну;
- Поставка специализированных компонентов (Xilinx, Altera, Analog Devices, Intersil, Interpoint, Microsemi, Aeroflex, Peregrine, Syfer, Eurofarad, Texas Instrument, Miteq, Cobham, E2V, MA-COM, Hittite, Mini-Circuits, General Dynamics и др.);

Помимо этого, одним из направлений компании «ЭлектроПласт» является направление «Источники питания». Мы предлагаем Вам помощь Конструкторского отдела:

- Подбор оптимального решения, техническое обоснование при выборе компонента;
- Подбор аналогов;
- Консультации по применению компонента;
- Поставка образцов и прототипов;
- Техническая поддержка проекта;
- Защита от снятия компонента с производства.



#### Как с нами связаться

**Телефон:** 8 (812) 309 58 32 (многоканальный)

**Факс:** 8 (812) 320-02-42

**Электронная почта:** [org@eplast1.ru](mailto:org@eplast1.ru)

**Адрес:** 198099, г. Санкт-Петербург, ул. Калинина, дом 2, корпус 4, литера А.