

## Features

- Supply Voltage 4.5V to 5.5V
- Operating Temperature Range  $-40^{\circ}\text{C}$  to  $+85^{\circ}\text{C}$
- Minimal External Circuitry Requirements, No RF Components on the PC Board Except Matching to the Receiver Antenna
- High Sensitivity, Especially at Low Data Rates
- Sensitivity Reduction Possible Even While Receiving
- Fully Integrated VCO
- Low Power Consumption Due to Configurable Self-polling with a Programmable Time Frame Check
- Single-ended RF Input for Easy Matching to  $\lambda / 4$  Antenna or Printed Antenna on PCB
- Low-cost Solution Due to High Integration Level
- ESD Protection According to MIL-STD 883 (4 KV HBM) Except Pin POUT (2 KV HBM)
- High Image Frequency Suppression Due to 1 MHz IF in Conjunction With a SAW Front-end Filter. Up to 40 dB is Thereby Achievable With Newer SAWs
- Programmable Output Port for Sensitivity Selection or for Controlling External Periphery
- Communication to the Microcontroller Possible via a Single, Bi-directional Data Line
- Power Management (Polling) is also Possible by Means of a Separate Pin via the Microcontroller

## 1. Description

The ATA3745 is a multi-chip PLL receiver device supplied in an SO20 package. It has been specially developed for the demands of RF low-cost data transmission systems with low data rates from 1 kBaud to 10 kBaud in Manchester or Bi-phase code. The receiver is well-suited to operate with Atmel's PLL RF transmitter ATA2745. It can be used in the frequency receiving range of  $f_0 = 310\text{ MHz}$  to  $440\text{ MHz}$  for ASK data transmission. All the statements made below refer to  $433.92\text{ MHz}$  and  $315\text{ MHz}$  applications.

The main applications of the ATA3745 are in the areas of outside temperature metering, socket control, garage door openers, consumption metering, light/fan or air-conditioning control, jalousies, wireless keyboards, and various other consumer market applications.



## UHF ASK/FSK Receiver

## ATA3745



**Figure 1-1. System Block Diagram**

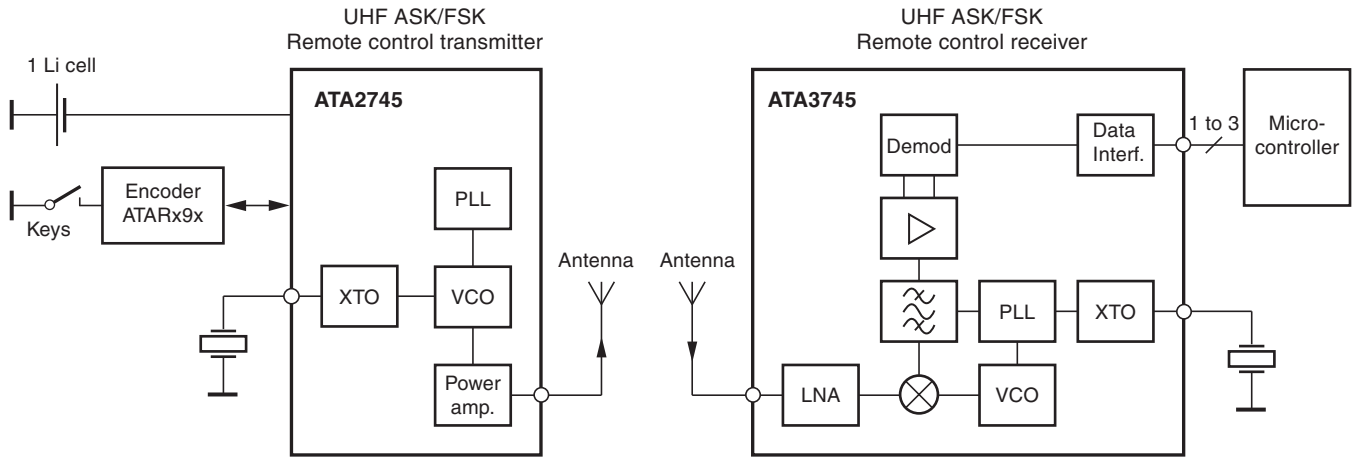

**Figure 1-2. Block Diagram**

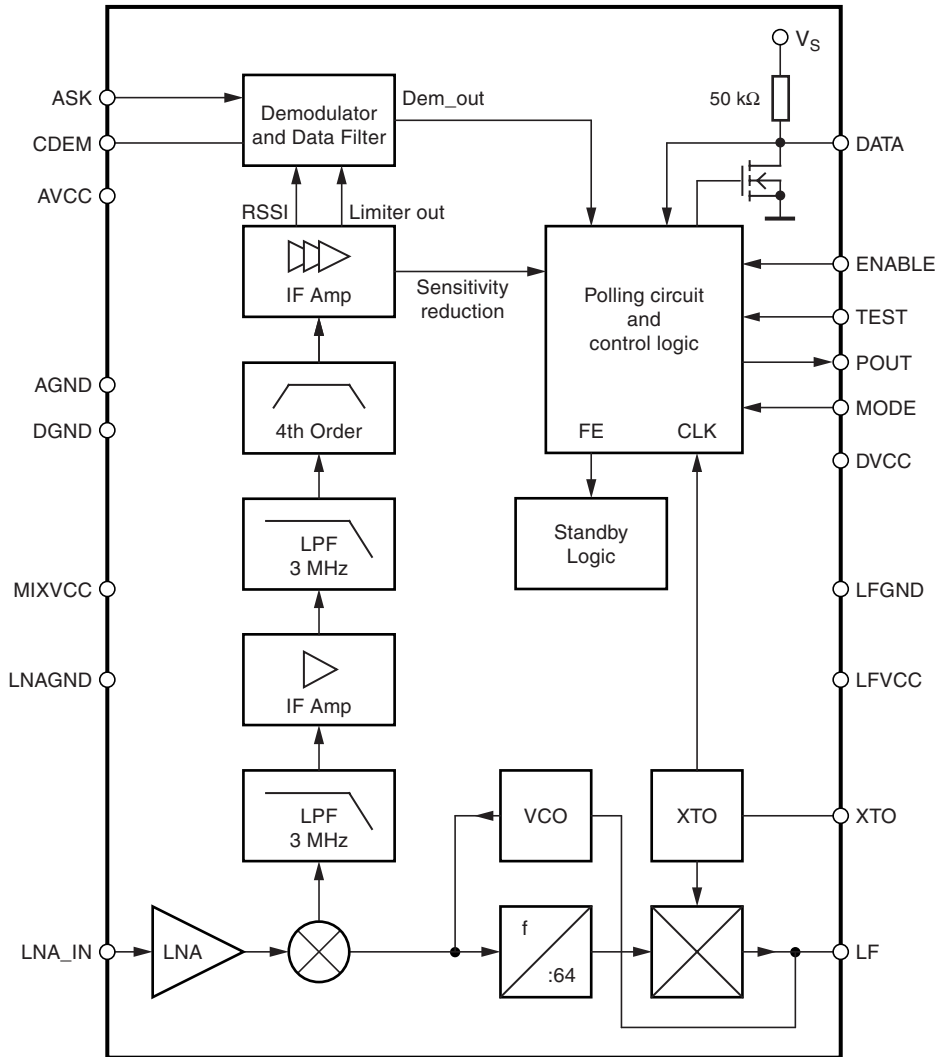

## 2. Pin Configuration

Figure 2-1. Pinning SO20

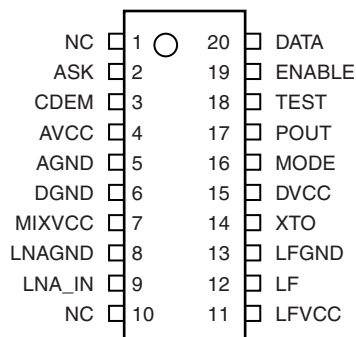

Table 2-1. Pin Description

Pin	Symbol	Function
1	NC	Not connected
2	ASK	ASK high
3	CDEM	Lower cut-off frequency data filter
4	AVCC	Analog power supply
5	AGND	Analog ground
6	DGND	Digital ground
7	MIXVCC	Power supply mixer
8	LNAGND	High-frequency ground LNA and mixer
9	LNA_IN	RF input
10	NC	Not connected
11	LFVCC	Power supply VCO
12	LF	Loop filter
13	LFGND	Ground VCO
14	XTO	Crystal oscillator
15	DVCC	Digital power supply
16	MODE	Selecting 433.92 MHz/315 MHz. Low: 4.90625 MHz (USA), High: 6.76438 MHz (Europe)
17	POUT	Programmable output port
18	TEST	Test pin, during operation at GND
19	ENABLE	Enables the polling mode. Low: polling mode off (sleep mode). High: polling mode on (active mode)
20	DATA	Data output/configuration input

### 3. RF Front End

The RF front end of the receiver is a heterodyne configuration that converts the input signal into a 1-MHz IF signal. As shown in the block diagram, the front end consists of an LNA (low noise amplifier), LO (local oscillator), a mixer and an RF amplifier.

The LO generates the carrier frequency for the mixer via a PLL synthesizer. The XTO (crystal oscillator) generates the reference frequency  $f_{XTO}$ . The VCO (voltage-controlled oscillator) generates the drive voltage frequency  $f_{LO}$  for the mixer.  $f_{LO}$  is dependent on the voltage at pin LF.  $f_{LO}$  is divided by a factor of 64. The divided frequency is compared to  $f_{XTO}$  by the phase frequency detector. The current output of the phase frequency detector is connected to a passive loop filter and thereby generates the control voltage  $V_{LF}$  for the VCO. By means of that configuration,  $V_{LF}$  is controlled such that  $f_{LO} / 64$  is equal to  $f_{XTO}$ . If  $f_{LO}$  is determined,  $f_{XTO}$  can be calculated using the following formula:

$$f_{XTO} = \frac{f_{LO}}{64}$$

The XTO is a one-pin oscillator that operates at the series resonance of the quartz crystal. [Figure 3-1](#) shows the proper layout, with the crystal connected to GND via a capacitor  $C_L$ . The value of that capacitor is recommended by the crystal supplier. The value of  $C_L$  should be optimized for the individual board layout to achieve the exact value of  $f_{XTO}$  and thereby of  $f_{LO}$ . When designing the system in terms of receiving bandwidth, the accuracy of the crystal and XTO must be considered.

**Figure 3-1.** PLL Peripherals

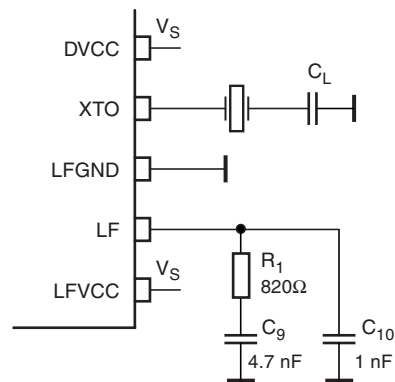

The passive loop filter connected to pin LF is designed for a loop bandwidth of  $B_{Loop} = 100$  kHz. This value for  $B_{Loop}$  exhibits the best possible noise performance of the LO. [Figure 3-1](#) shows the appropriate loop filter components to achieve the desired loop bandwidth. If the filter components are changed for any reason, please note that the maximum capacitive load at pin LF is limited. If the capacitive load is exceeded, a bit check may no longer be possible since  $f_{LO}$  cannot settle in time before the bit check starts to evaluate the incoming data stream. Therefore, self polling also does not work in that case.

$f_{LO}$  is determined by the RF input frequency  $f_{RF}$  and the IF frequency  $f_{IF}$  using the following formula:  $f_{LO} = f_{RF} - f_{IF}$

To determine  $f_{LO}$ , the construction of the IF filter must be considered at this point. The nominal IF frequency is  $f_{IF} = 1$  MHz. To achieve a good accuracy of the filter's corner frequencies, the filter is tuned by the crystal frequency  $f_{XTO}$ . This means that there is a fixed relation between  $f_{IF}$  and  $f_{LO}$  that depends on the logic level at pin MODE. This is described by the following formulas:

$$\text{MODE} = 0 \text{ (USA)} \quad f_{IF} = \frac{f_{LO}}{314}$$

$$\text{MODE} = 1 \text{ (Europe)} \quad f_{IF} = \frac{f_{LO}}{432.92}$$

The relation is designed to achieve the nominal IF frequency of  $f_{IF} = 1$  MHz for most applications. For applications where  $f_{RF} = 315$  MHz, the MODE must be set to "0". In the case of  $f_{RF} = 433.92$  MHz, the MODE must be set to "1". For other RF frequencies,  $f_{IF}$  is not equal to 1 MHz.  $f_{IF}$  is then dependent on the logical level at pin MODE and on  $f_{RF}$ . [Table 3-1](#) summarizes the different conditions.

The RF input either from an antenna or from a generator must be transformed to the RF input pin LNA\_IN. The input impedance of that pin is provided in the electrical parameters. The parasitic board inductances and capacitances also influence the input matching. The RF receiver ATA3745 exhibits its highest sensitivity at the best signal-to-noise ratio (SNR) in the LNA. Hence, noise matching is the best choice for designing the transformation network.

A good practice when designing the network is to start with power matching. From that starting point, the values of the components can be varied to some extent to achieve the best sensitivity.

If a SAW is implemented into the input network, a mirror frequency suppression of  $\Delta P_{Ref} = 40$  dB can be achieved. There are SAWs available that exhibit a notch at  $\Delta f = 2$  MHz. These SAWs work best for an intermediate frequency of IF = 1 MHz. The selectivity of the receiver is also improved by using a SAW. In typical automotive applications, a SAW is used.

[Figure 3-2 on page 6](#) shows a typical input matching network for  $f_{RF} = 315$  MHz and  $f_{RF} = 433.92$  MHz using a SAW. [Figure 3-3 on page 6](#) illustrates an input matching to 50Ω without a SAW. The input matching networks shown in [Figure 3-3 on page 6](#) are the reference networks for the parameters given in the section "[Electrical Characteristics](#)" on [page 23](#).

**Table 3-1.** Calculation of LO and IF Frequency

Conditions	Local Oscillator Frequency	Intermediate Frequency
$f_{RF} = 315$ MHz, MODE = 0	$f_{LO} = 314$ MHz	$f_{IF} = 1$ MHz
$f_{RF} = 433.92$ MHz, MODE = 1	$f_{LO} = 432.92$ MHz	$f_{IF} = 1$ MHz
$300 \text{ MHz} < f_{RF} < 365 \text{ MHz}$ , MODE = 0	$f_{LO} = \frac{f_{RF}}{1 + \frac{1}{314}}$	$f_{IF} = \frac{f_{LO}}{314}$
$365 \text{ MHz} < f_{RF} < 450 \text{ MHz}$ , MODE = 1	$f_{LO} = \frac{f_{RF}}{1 + \frac{1}{432.92}}$	$f_{IF} = \frac{f_{LO}}{432.92}$

**Figure 3-2.** Input Matching Network With SAW Filter

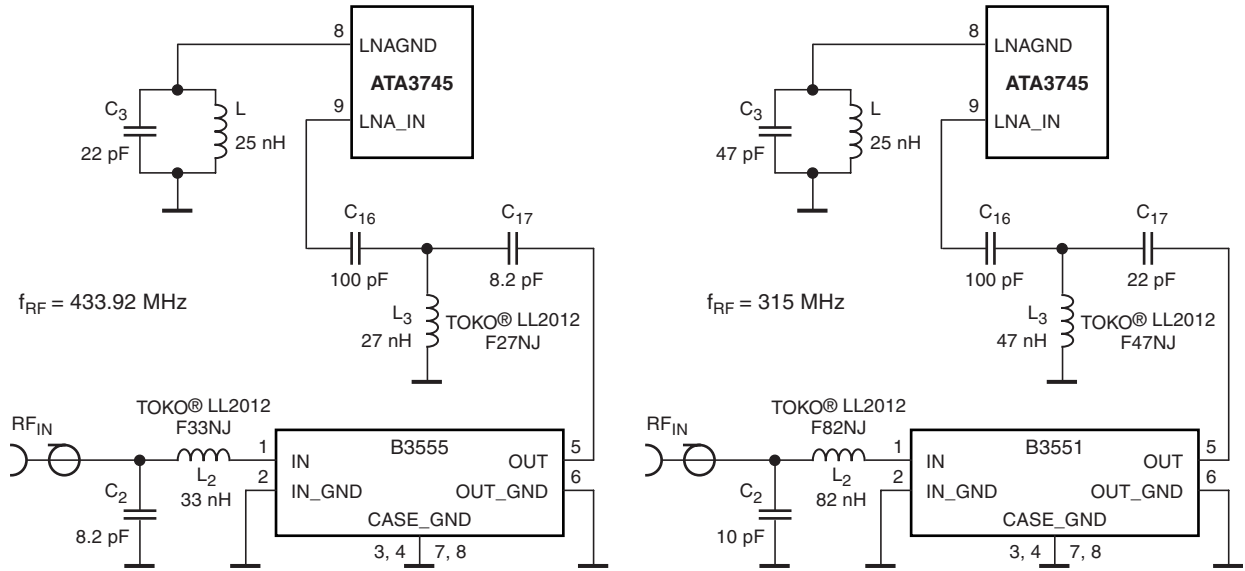

**Figure 3-3.** Input Matching Network Without SAW Filter

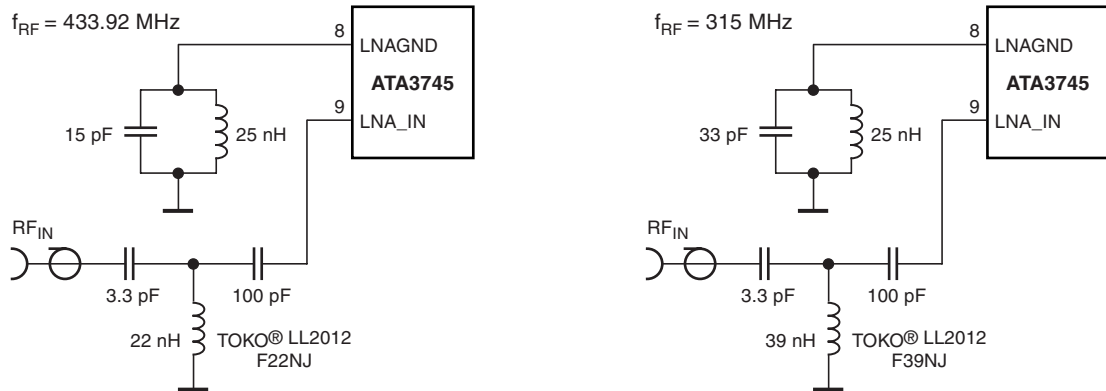

Please note that for all coupling conditions (see [Figure 3-2](#) and [Figure 3-3](#)), the bond wire inductivity of the LNA ground is compensated. C3 forms a series resonance circuit together with the bond wire. L = 25 nH is a feed inductor to establish a DC path. Its value is not critical but must be large enough not to detune the series resonance circuit. For cost reduction, this inductor can be easily printed on the PCB. This configuration improves the sensitivity of the receiver by about 1 dB to 2 dB.

## 4. Analog Signal Processing

### 4.1 IF Amplifier

The signals coming from the RF front end are filtered by the fully integrated 4th-order IF filter. The IF center frequency is  $f_{IF} = 1$  MHz for applications where  $f_{RF} = 315$  MHz or  $f_{RF} = 433.92$  MHz is used. For other RF input frequencies, refer to [Table 3-1 on page 5](#) to determine the center frequency.

The receiver ATA3745 employs an IF bandwidth of  $B_{IF} = 600$  kHz. This IC can be used together with the ATA2745. SAW transmitters exhibit much higher transmit frequency tolerances compared to PLL transmitters. Generally, it is necessary to use  $B_{IF} = 600$  kHz together with such transmitters.

### 4.2 RSSI Amplifier

The subsequent RSSI amplifier enhances the output signal of the IF amplifier before it is fed into the demodulator. The dynamic range of this amplifier is  $\Delta R_{RSSI} = 60$  dB. If the RSSI amplifier is operated within its linear range, the best signal-to-noise ratio (SNR) is maintained in ASK mode. If the dynamic range is exceeded by the transmitter signal, the SNR is defined by the ratio of the maximum RSSI output voltage and the RSSI output voltage due to a disturber. The dynamic range of the RSSI amplifier is exceeded if the RF input signal is about 60 dB higher compared to the RF input signal at full sensitivity.

Since different RF input networks may exhibit slightly different values for the LNA gain, the sensitivity values given in the electrical characteristics refer to a specific input matching. This matching is illustrated in [Figure 3-3 on page 6](#) and exhibits the best possible sensitivity.

### 4.3 Demodulator and Data Filter

The signal coming from the RSSI amplifier is converted into the raw data signal by the ASK demodulator.

In ASK mode, an automatic threshold control (ATC) circuit is employed to set the detection reference voltage to a value where a good SNR is achieved. This circuit also implies the effective suppression of any kind of in-band noise signals or competing transmitters. If the SNR exceeds 10 dB, the data signal can be detected properly.

The output signal of the demodulator is filtered by the data filter before it is fed into the digital signal processing circuit. The data filter improves the SNR as its band-pass can be adapted to the characteristics of the data signal. The data filter consists of a 1st-order high-pass and a 1st-order low-pass filter.

The high-pass filter cut-off frequency is defined by an external capacitor connected to pin CDEM. The cut-off frequency of the high-pass filter is defined by the following formula:

$$f_{cu\_DF} = \frac{1}{2 \times \pi \times 30 \text{ k}\Omega \times \text{CDEM}}$$

In self-polling mode, the data filter must settle very rapidly to achieve a low current consumption. Therefore, CDEM cannot be increased to very high values if self polling is used. On the other hand, CDEM must be large enough to meet the data filter requirements according to the data signal. Recommended values for CDEM are given in the section [“Electrical Characteristics” on page 23](#).

The cut-off frequency of the low-pass filter is defined by the selected baud rate range (BR\_Range). BR\_Range is defined in the OPMODE register (refer to “[Configuration of the Receiver](#)” on page 18). BR\_Range must be set in accordance to the used baud rate.

The ATA3745 is designed to operate with data encoding where the DC level of the data signal is 50%. This is valid for Manchester and Bi-phase encoding. If other modulation schemes are used, the DC level should always remain within the range of  $V_{DC\_min} = 33\%$  and  $V_{DC\_max} = 66\%$ . The sensitivity may be reduced by up to 1.5 dB in that condition.

Each BR\_Range is also defined by a minimum and a maximum edge-to-edge time ( $t_{ee\_sig}$ ). These limits are defined in the section “[Electrical Characteristics](#)” on page 23. They should not be exceeded to maintain full sensitivity of the receiver.

## 4.4 Receiving Characteristics

The RF receiver ATA3745 can be operated with and without a SAW front end filter. The selectivity with and without a SAW front-end filter is illustrated in [Figure 4-1](#). This example relates to ASK mode of the ATA3745. Note that the mirror frequency is reduced by 40 dB. The plots are printed relative to the maximum sensitivity. If a SAW filter is used, an insertion loss of about 4 dB must be considered.

When designing the system in terms of receiving bandwidth, the LO deviation must be considered as it also determines the IF center frequency. The total LO deviation is calculated to be the sum of the deviation of the crystal and the XTO deviation of the ATA3745. Low-cost crystals are specified to be within  $\pm 100$  ppm. The XTO deviation of the ATA3745 is an additional deviation due to the XTO circuit. This deviation is specified to be  $\pm 50$  ppm. If a crystal of  $\pm 100$  ppm is used, the total deviation is  $\pm 150$  ppm in that case. Note that the receiving bandwidth and the IF-filter bandwidth are equivalent in ASK mode.

**Figure 4-1.** Receiving Frequency Response

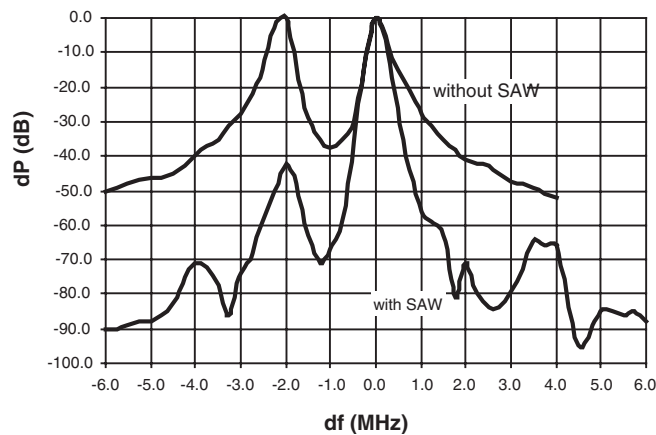



## 5. Polling Circuit and Control Logic

The receiver is designed to consume less than 1 mA while being sensitive to signals from a corresponding transmitter. This is achieved via the polling circuit. This circuit enables the signal path periodically for a short time. During this time, the bit check logic verifies the presence of a valid transmitter signal. Only if a valid signal is detected does the receiver remain active and transfer the data to the connected microcontroller. If there is no valid signal present, the receiver is in sleep mode most of the time, resulting in low current consumption. This condition is called polling mode. A connected microcontroller is disabled during that time.

All relevant parameters of the polling logic can be configured by the connected microcontroller. This flexibility enables the user to meet the specifications in terms of current consumption, system response time, data rate, etc.

Regarding the number of connection wires to the microcontroller, the receiver is very flexible. It can be either operated by a single bi-directional line to save ports to the connected microcontroller, or it can be operated by up to three uni-directional ports.

### 5.1 Basic Clock Cycle of the Digital Circuitry

The complete timing of the digital circuitry and the analog filtering is derived from one clock. [Figure 5-1](#) shows how this clock cycle  $T_{CLK}$  is derived from the crystal oscillator (XTO) in combination with a divider. The division factor is controlled by the logical state at pin MODE. As described in “RF Front End” on page 4, the frequency of the crystal oscillator ( $f_{XTO}$ ) is defined by the RF input signal ( $f_{RFIn}$ ) which also defines the operating frequency of the local oscillator ( $f_{LO}$ ).

**Figure 5-1.** Generation of the Basic Clock Cycle

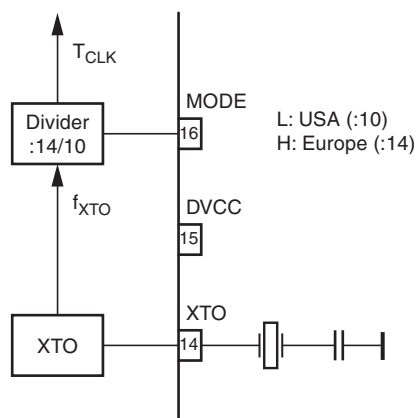

Pin MODE can now be set in accordance with the desired clock cycle  $T_{CLK}$ .  $T_{CLK}$  controls the following application-relevant parameters:

- Timing of the polling circuit including bit check
- Timing of analog and digital signal processing
- Timing of register programming
- Frequency of the reset marker
- IF filter center frequency ( $f_{IF0}$ )

Most applications are dominated by two transmission frequencies:  $f_{\text{Send}} = 315 \text{ MHz}$  is mainly used in the USA,  $f_{\text{Send}} = 433.92 \text{ MHz}$  in Europe. In order to ease the usage of all  $T_{\text{Clk}}$ -dependent parameters, the electrical characteristics display three conditions for each parameter.

- USA applications  
( $f_{\text{XTO}} = 4.90625 \text{ MHz}$ ,  $\text{MODE} = \text{L}$ ,  $T_{\text{Clk}} = 2.0383 \mu\text{s}$ )
- European applications  
( $f_{\text{XTO}} = 6.76438 \text{ MHz}$ ,  $\text{MODE} = \text{H}$ ,  $T_{\text{Clk}} = 2.0697 \mu\text{s}$ )
- Other applications  
( $T_{\text{Clk}}$  is dependent on  $f_{\text{XTO}}$  and on the logical state of pin  $\text{MODE}$ . The electrical characteristic is given as a function of  $T_{\text{Clk}}$ ).

The clock cycle of some function blocks depends on the selected baud rate range ( $\text{BR\_Range}$ ) which is defined in the  $\text{OPMODE}$  register. This clock cycle  $T_{\text{XClk}}$  is defined by the following formulas for further reference:

$\text{BR\_Range} =$	$\text{BR\_Range0:}$	$T_{\text{XClk}} = 8 \times T_{\text{Clk}}$
	$\text{BR\_Range1:}$	$T_{\text{XClk}} = 4 \times T_{\text{Clk}}$
	$\text{BR\_Range2:}$	$T_{\text{XClk}} = 2 \times T_{\text{Clk}}$
	$\text{BR\_Range3:}$	$T_{\text{XClk}} = 1 \times T_{\text{Clk}}$

## 5.2 Polling Mode

According to [Figure 3-2 on page 6](#), the receiver stays in polling mode in a continuous cycle of three different modes. In sleep mode, the signal processing circuitry is disabled for the time period  $T_{\text{Sleep}}$  while consuming low current of  $I_{\text{S}} = I_{\text{Soff}}$ . During the start-up period,  $T_{\text{Startup}}$ , all signal processing circuits are enabled and settled. In the following bit check mode, the incoming data stream is analyzed bit by bit looking for a valid transmitter signal. If no valid signal is present, the receiver is set back to sleep mode after the period  $T_{\text{Bitcheck}}$ . This period varies check by check as it is a statistical process. An average value for  $T_{\text{Bitcheck}}$  is given in the section [“Electrical Characteristics” on page 23](#). During  $T_{\text{Startup}}$  and  $T_{\text{Bitcheck}}$  the current consumption is  $I_{\text{S}} = I_{\text{Son}}$ . The average current consumption in polling mode is dependent on the duty cycle of the active mode and can be calculated as:

$$I_{\text{Spoll}} = \frac{I_{\text{Soff}} \times T_{\text{Sleep}} + I_{\text{Son}} \times (T_{\text{Startup}} + T_{\text{Bitcheck}})}{T_{\text{Sleep}} + T_{\text{Startup}} + T_{\text{Bitcheck}}}$$

During  $T_{\text{Sleep}}$  and  $T_{\text{Startup}}$ , the receiver is not sensitive to a transmitter signal. To guarantee the reception of a transmitted command, the transmitter must start the telegram with an adequate preburst. The required length of the preburst is dependent on the polling parameters  $T_{\text{Sleep}}$ ,  $T_{\text{Startup}}$ ,  $T_{\text{Bitcheck}}$  and the startup time of a connected microcontroller ( $T_{\text{Start}_{\mu\text{C}}}$ ).  $T_{\text{Bitcheck}}$  thus depends on the actual bit rate and the number of bits ( $N_{\text{Bitcheck}}$ ) to be tested.

The following formula indicates how to calculate the preburst length.

$$T_{\text{Preamble}} \geq T_{\text{Sleep}} + T_{\text{Startup}} + T_{\text{Bitcheck}} + T_{\text{Start}_{\mu\text{C}}}$$

### 5.2.1 Sleep Mode

The length of period  $T_{\text{Sleep}}$  is defined by the 5-bit word Sleep of the OPMODE register, the extension factor  $X_{\text{Sleep}}$  described in [Table 5-8 on page 20](#), and the basic clock cycle  $T_{\text{Clk}}$ . It is calculated to be:

$$T_{\text{Sleep}} = \text{Sleep} \times X_{\text{Sleep}} \times 1024 \times T_{\text{Clk}}$$

In US and European applications, the maximum value of  $T_{\text{Sleep}}$  is about 60 ms if  $X_{\text{Sleep}}$  is set to 1. The time resolution is about 2 ms in that case. The sleep time can be extended to almost half a second by setting  $X_{\text{Sleep}}$  to 8.  $X_{\text{Sleep}}$  can be set to 8 by bit  $X_{\text{SleepStd}}$  or by bit  $X_{\text{SleepTemp}}$ , resulting in a different mode of action as described below:

$X_{\text{SleepStd}} = 1$  implies the standard extension factor. The sleep time is always extended.

$X_{\text{SleepTemp}} = 1$  implies the temporary extension factor. The extended sleep time is used as long as every bit check is OK. If the bit check fails once, this bit is set back to 0 automatically, resulting in a regular sleep time. This functionality can be used to save current in presence of a modulated disturber similar to an expected transmitter signal. The connected microcontroller is rarely activated in that condition. If the disturber disappears, the receiver switches back to regular polling and is again sensitive to appropriate transmitter signals.

[Table 5-6 on page 19](#) shows how the highest register value of Sleep sets the receiver to a permanent sleep condition. The receiver remains in that condition until another value for Sleep is programmed into the OPMODE register. This function is desirable where several devices share a single data line.

**Figure 5-2. Polling Mode Flow Chart**

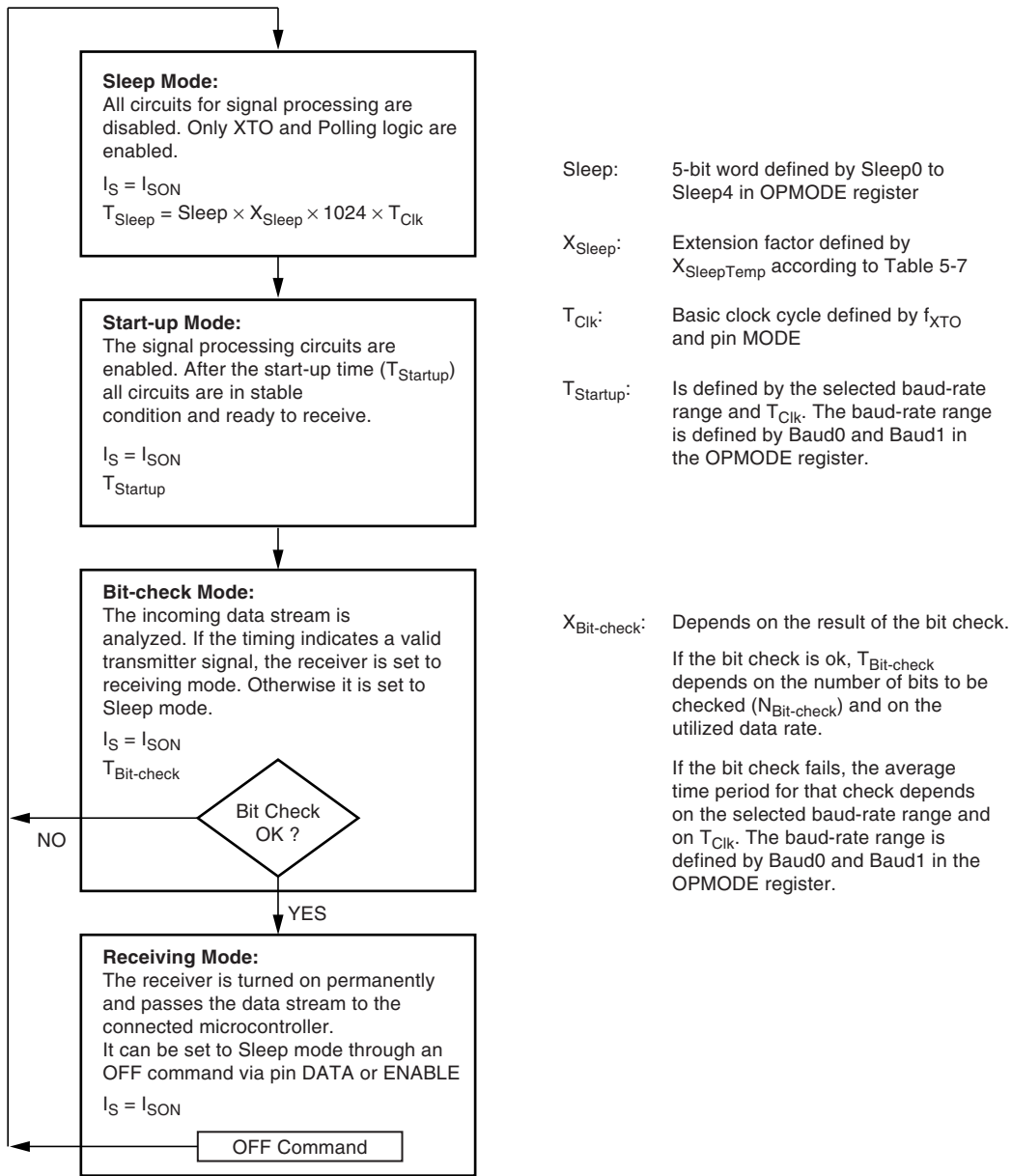

**Figure 5-3. Timing Diagram for a Completely Successful Bit Check**

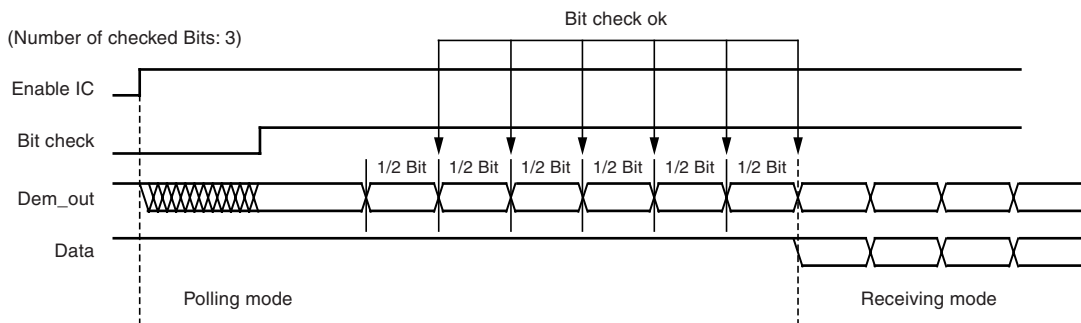

## 5.3 Bit Check Mode

In bit check mode, the incoming data stream is examined to distinguish between a valid signal from a corresponding transmitter and signals due to noise. This is done by subsequent time frame checks where the distances between 2 signal edges are continuously compared to a programmable time window. The maximum count of this edge-to-edge test, before the receiver switches to receiving mode, is also programmable.

### 5.3.1 Configuring the Bit Check

Assuming a modulation scheme that contains 2 edges per bit, two time frame checks verify one bit. This is valid for Manchester, Bi-phase and most other modulation schemes. The maximum count of bits to be checked can be set to 0, 3, 6 or 9 bits via the variable  $N_{\text{Bitcheck}}$  in the OPMODE register. This implies 0, 6, 12 and 18 edge-to-edge checks respectively. If  $N_{\text{Bitcheck}}$  is set to a higher value, the receiver is less likely to switch to the receiving mode due to noise. In the presence of a valid transmitter signal, the bit check takes less time if  $N_{\text{Bitcheck}}$  is set to a lower value. In polling mode, the bit check time is not dependent on  $N_{\text{Bitcheck}}$ . [Figure 5-3 on page 12](#) shows an example where 3 bits are tested successfully and the data signal is transferred to pin DATA.

[Figure 5-4](#) shows that the time window for the bit check is defined by two separate time limits. If the edge-to-edge time  $t_{ee}$  is in between the lower bit check limit  $T_{\text{Lim\_min}}$  and the upper bit check limit  $T_{\text{Lim\_max}}$ , the check will be continued. If  $t_{ee}$  is smaller than  $T_{\text{Lim\_min}}$  or  $t_{ee}$  exceeds  $T_{\text{Lim\_max}}$ , the bit check will be terminated and the receiver switches to sleep mode.

**Figure 5-4.** Valid Time Window for Bit Check

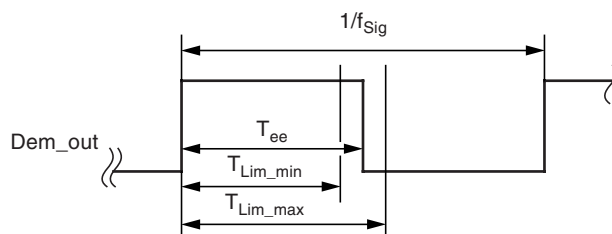

For best noise immunity it is recommended to use a low span between  $T_{\text{Lim\_min}}$  and  $T_{\text{Lim\_max}}$ . This is achieved using a fixed frequency at a 50% duty cycle for the transmitter preburst. A “11111...” or a “10101...” sequence in Manchester or Bi-phase is a good choice in this regard. A good compromise between receiver sensitivity and susceptibility to noise is a time window of  $\pm 25\%$  regarding the expected edge-to-edge time  $t_{ee}$ . Using preburst patterns that contain various edge-to-edge time periods, the bit check limits must be programmed according to the required span.

The bit check limits are determined by means of the formulas below:

$$T_{\text{Lim\_min}} = \text{Lim\_min} \times T_{\text{XClk}}$$

$$T_{\text{Lim\_max}} = (\text{Lim\_max} - 1) \times T_{\text{XClk}}$$

Lim\_min and Lim\_max are defined by a 5-bit word each within the LIMIT register.

Using the above formulas, Lim\_min and Lim\_max can be determined according to the required  $T_{\text{Lim\_min}}$ ,  $T_{\text{Lim\_max}}$  and  $T_{\text{XClk}}$ . The time resolution when defining  $T_{\text{Lim\_min}}$  and  $T_{\text{Lim\_max}}$  is  $T_{\text{XClk}}$ . The minimum edge-to-edge time  $t_{ee}$  ( $t_{\text{DATA\_L\_min}}$ ,  $t_{\text{DATA\_H\_min}}$ ) is defined in [Section “Receiving Mode” on page 15](#). Due to this, the lower limit should be set to  $\text{Lim\_min} \geq 10$ . The maximum value of the upper limit is  $\text{Lim\_max} = 63$ .

Figure 5-5, Figure 5-6 and Figure 5-7 illustrate the bit check for the default bit check limits  $Lim\_min = 14$  and  $Lim\_max = 24$ . When the IC is enabled, the signal processing circuits are enabled during  $T_{Startup}$ . The output of the demodulator ( $Dem\_out$ ) is undefined during that period. When the bit check becomes active, the bit check counter is clocked with the cycle  $T_{XCLK}$ .

Figure 5-5 shows how the bit check proceeds if the bit-check counter value  $CV\_Lim$  is within the limits defined by  $Lim\_min$  and  $Lim\_max$  at the occurrence of a signal edge. In Figure 5-7, the bit check fails as the value  $CV\_lim$  is lower than the limit  $Lim\_min$ . The bit check also fails if  $CV\_Lim$  reaches  $Lim\_max$ . This is illustrated in Figure 5-8 on page 15.

**Figure 5-5.** Timing Diagram During Bit Check

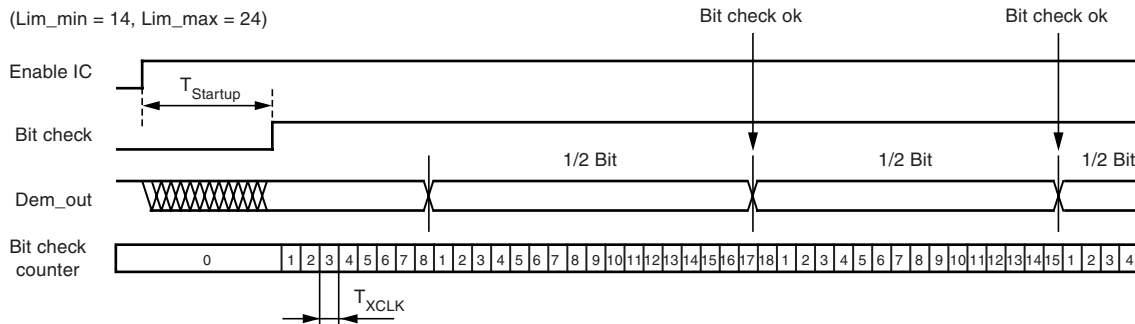

**Figure 5-6.** Timing Diagram for Failed Bit Check (Condition:  $CV\_Lim < Lim\_min$ )

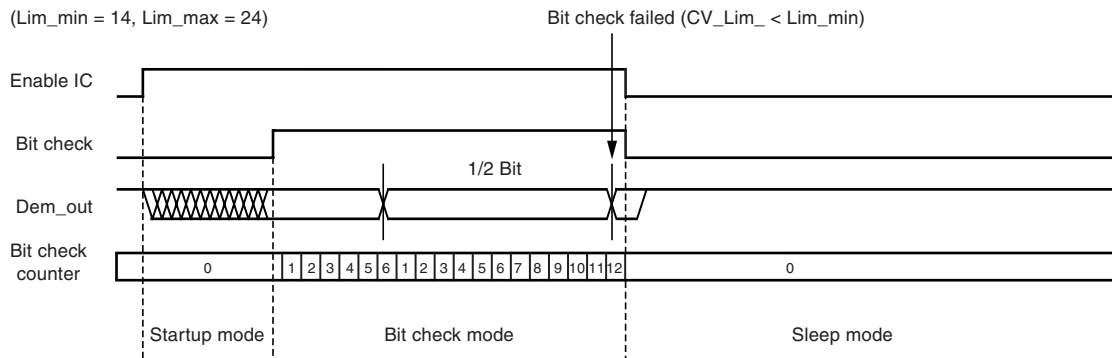

**Figure 5-7.** Timing Diagram for Failed Bit Check (Condition:  $CV\_Lim \geq Lim\_max$ )

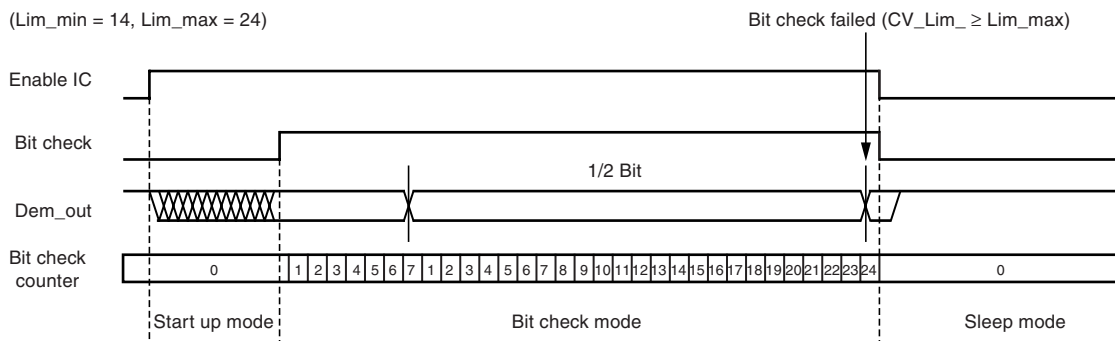

### 5.3.2 Duration of the Bit Check

If no transmitter signal is present during the bit check, the output of the demodulator delivers random signals. The bit check is a statistical process and  $T_{\text{Bitcheck}}$  varies for each check. Therefore, an average value for  $T_{\text{Bitcheck}}$  is given in the section “[Electrical Characteristics](#)” on [page 23](#).  $T_{\text{Bitcheck}}$  depends on the selected baud rate range and on  $T_{\text{Clk}}$ . A higher baud rate range causes a lower value for  $T_{\text{Bitcheck}}$  resulting in lower current consumption in polling mode.

In the presence of a valid transmitter signal,  $T_{\text{Bitcheck}}$  is dependant on the frequency of that signal,  $f_{\text{Sig}}$  and the count of the checked bits,  $N_{\text{Bitcheck}}$ . A higher value for  $N_{\text{Bitcheck}}$  thereby results in a longer period for  $T_{\text{Bitcheck}}$  requiring a higher value for the transmitter preburst  $T_{\text{Preburst}}$ .

## 5.4 Receiving Mode

If the bit check has been successful for all bits specified by  $N_{\text{Bitcheck}}$ , the receiver switches to receiving mode. As seen in [Figure 5-4 on page 13](#), the internal data signal is switched to pin DATA in that case. A connected microcontroller can be woken up by the negative edge at pin DATA. The receiver stays in that condition until it is switched back to polling mode explicitly.

### 5.4.1 Digital Signal Processing

The data from the demodulator (Dem\_out) is digitally processed in different ways and as a result converted into the output signal data. This processing depends on the selected baud rate range (BR\_Range). [Figure 5-8](#) illustrates how Dem\_out is synchronized by the extended clock cycle  $T_{\text{XClk}}$ . This clock is also used for the bit check counter. Data can change its state only after  $T_{\text{XClk}}$  elapsed. The edge-to-edge time period  $t_{\text{ee}}$  of the Data signal, as a result, is always an integral multiple of  $T_{\text{XClk}}$ .

The minimum time period between two edges of the data signal is limited to  $t_{\text{ee}} \geq T_{\text{DATA\_min}}$ . This implies an efficient suppression of spikes at the DATA output. At the same time, it limits the maximum frequency of edges at DATA. This eases the interrupt handling of a connected microcontroller.  $T_{\text{DATA\_min}}$  is to some extent affected by the preceding edge-to-edge time interval  $t_{\text{ee}}$  as illustrated in [Figure 5-9 on page 16](#). If  $t_{\text{ee}}$  is in between the specified bit check limits, the following level is frozen for the time period  $T_{\text{DATA\_min}} = t_{\text{min1}}$ ; if  $t_{\text{ee}}$  is outside the bit check limits,  $T_{\text{DATA\_min}} = t_{\text{min2}}$  is the relevant stable time period.

The maximum time period for DATA to be low is limited to  $T_{\text{DATA\_L\_max}}$ . This function ensures a finite response time during programming or switching off the receiver via pin DATA.  $T_{\text{DATA\_L\_max}}$  is thereby longer than the maximum time period indicated by the transmitter data stream. [Figure 5-10 on page 16](#) gives an example where Dem\_out remains low after the receiver has switched to receiving mode.

**Figure 5-8.** Synchronization of the Demodulator Output

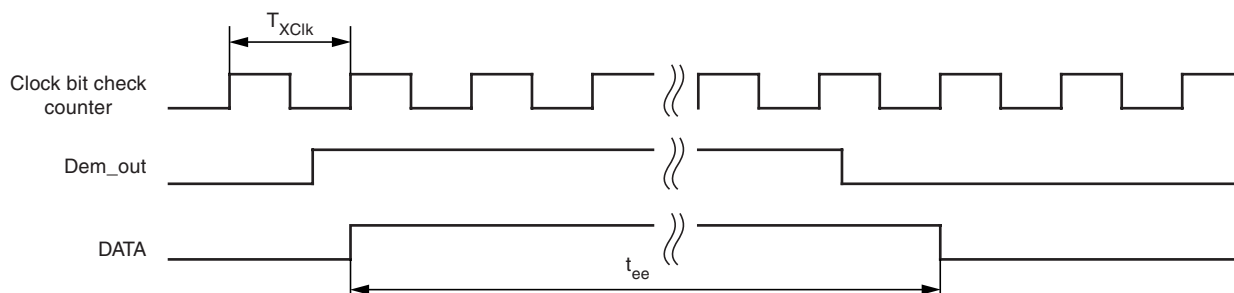

**Figure 5-9.** Debouncing of the Demodulator Output

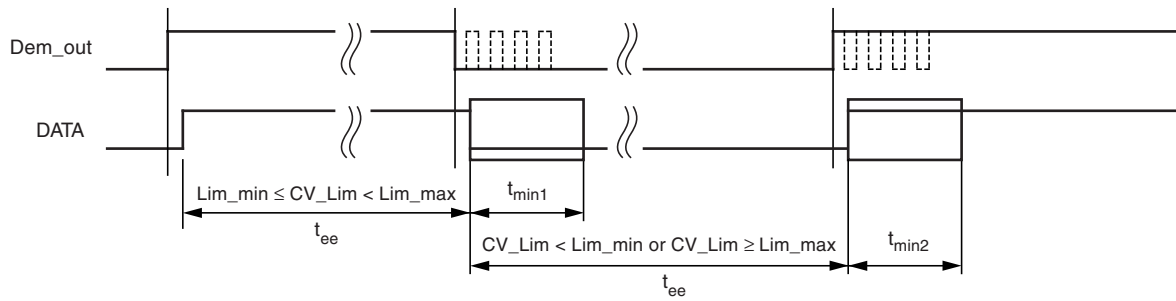

**Figure 5-10.** Steady L State Limited DATA Output Pattern after Transmission

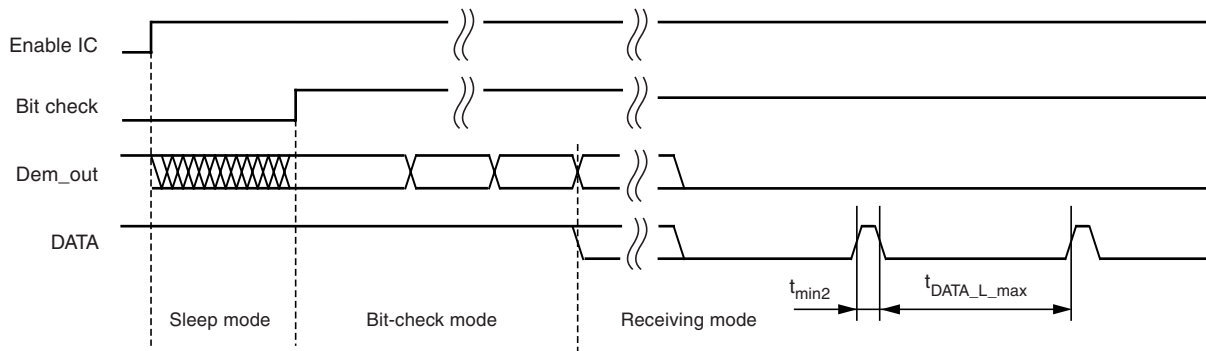

After the end of a data transmission, the receiver remains active and random noise pulses appear at pin DATA. The edge-to-edge time period  $t_{ee}$  of the majority of these noise pulses is equal to or slightly higher than  $T_{DATA\_min}$ .

#### 5.4.2 Switching the Receiver Back to Sleep Mode

The receiver can be set back to polling mode via pin DATA or via pin ENABLE.

When using pin DATA, this pin must be pulled to low for the period  $t_1$  by the connected microcontroller. [Figure 5-11 on page 17](#) illustrates the timing of the OFF command (see also [Figure 5-15 on page 22](#)). The minimum value of  $t_1$  depends on the BR\_Range. The maximum value for  $t_1$  is not limited, but it is recommended not to exceed the specified value to prevent erasing the reset marker. This item is explained in more detail in [“Configuration of the Receiver” on page 18](#). Setting the receiver to sleep mode via DATA is achieved by programming bit 1 of the OPMODE register to “1”. Only one synchronous pulse ( $t_3$ ) is issued.

The duration of the OFF command is determined by the sum of  $t_1$ ,  $t_2$  and  $t_{10}$ . After the OFF command, the sleep time  $T_{Sleep}$  elapses. Note that the capacitive load at pin DATA is limited. The resulting time constant  $t$  together with an optional external pull-up resistor should not be exceeded, to ensure proper operation.

If the receiver is set to polling mode via pin ENABLE, an “L” pulse ( $T_{Doze}$ ) must be issued at that pin. [Figure 5-12 on page 17](#) illustrates the timing of that command. After the positive edge of this pulse, the sleep time  $T_{Sleep}$  elapses. The receiver remains in sleep mode as long as ENABLE is held to “L”. If the receiver is polled exclusively by a microcontroller,  $T_{Sleep}$  can be programmed to “0” to enable an instantaneous response time. This command is the faster option than via pin DATA, at the cost of an additional connection to the microcontroller.



Figure 5-11. Timing Diagram of the OFF Command Via Pin DATA

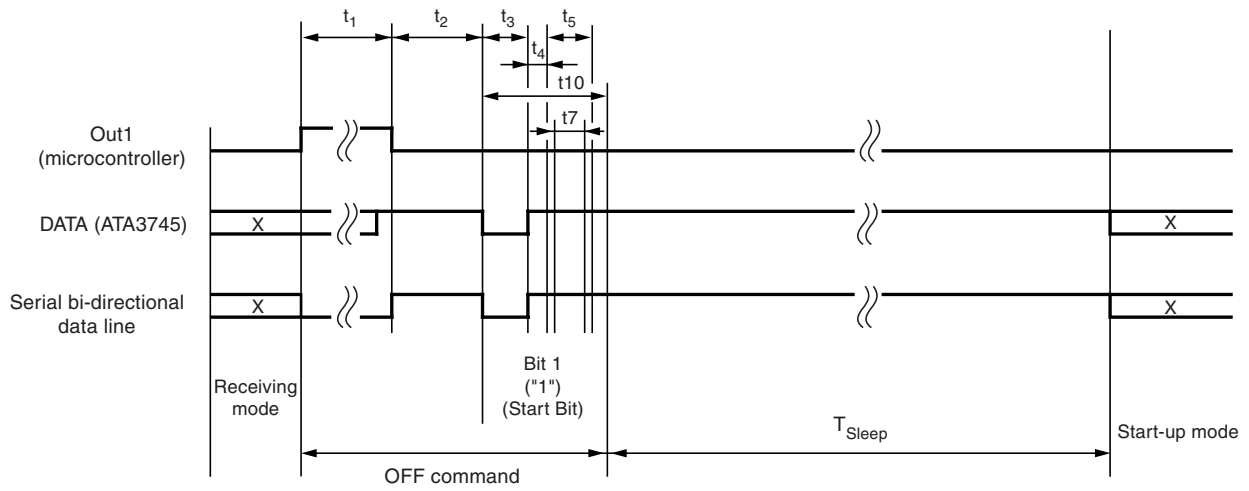
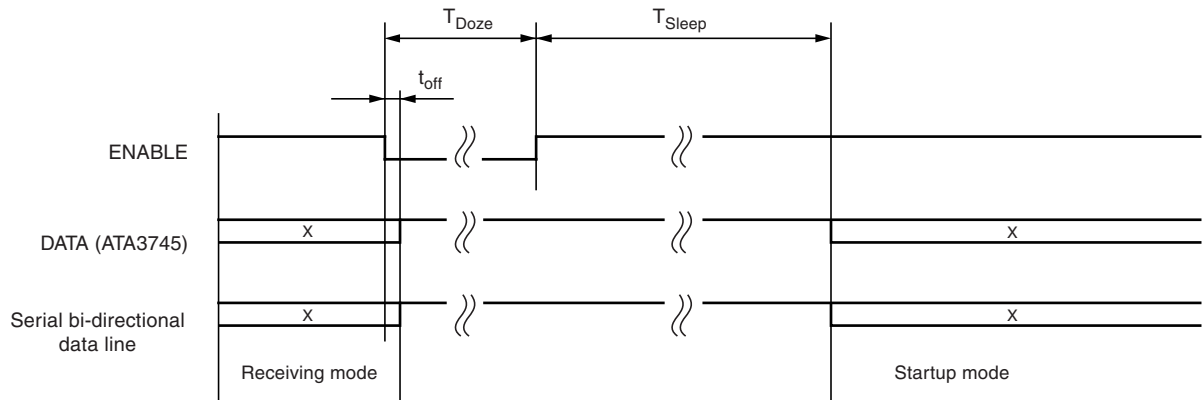

Figure 5-12. Timing Diagram of the OFF Command Via Pin ENABLE



## 5.5 Configuration of the Receiver

The ATA3745 receiver is configured via two 12-bit RAM registers called OPMODE and LIMIT. The registers can be programmed by means of the bi-directional DATA port. If the register contents have changed due to a voltage drop, this condition is indicated by a certain output pattern called reset marker (RM). The receiver must be reprogrammed in that case. After a power-on reset (POR), the registers are set to default mode. If the receiver is operated in default mode, there is no need to program the registers.

Table 5-2 shows the structure of the registers. Table 5-1 shows the effect of bit 1 and bit 2 in programming the registers: bit 1 defines if the receiver is set back to polling mode via the OFF command (see “Receiving Mode” on page 15), or if it is programmed. Bit 2 represents the register address. It selects the appropriate register to be programmed.

**Table 5-1.** Effect of Bit 1 and Bit 2 in Programming the Registers

Bit 1	Bit 2	Action
1	x	The receiver is set back to polling mode (OFF command)
0	1	The OPMODE register is programmed
0	0	The LIMIT register is programmed

Table 5-3 on page 19 and the following illustrate the effect of the individual configuration words. The default configuration is highlighted for each word.

BR\_Range sets the appropriate baud rate range. At the same time it defines X<sub>Sleep</sub>. X<sub>Sleep</sub> is used to define the bit check limits T<sub>Lim\_min</sub> and T<sub>Lim\_max</sub> as shown in Table 5-3 on page 19.

POUT can be used to control the sensitivity of the receiver. In that application, POUT is set to “1” to reduce the sensitivity. This implies that the receiver operates with full sensitivity after a POR.

**Table 5-2.** Effect of the Configuration Words within the Registers

Bit1	Bit2	Bit2	Bit4	Bit5	Bit6	Bit7	Bit8	Bit9	Bit10	Bit11	Bit12	Bit13	Bit14
<b>OFF Command</b>													
1													
<b>OPMODE Register</b>													
0	1	BR_Range		N <sub>Bitcheck</sub>		V <sub>POUT</sub>	Sleep					X <sub>Sleep</sub>	
0	1	Baud1	Baud0	BitChk1	BitChk0	POUT	Sleep4	Sleep3	Sleep2	Sleep1	Sleep0	X <sub>Sleep Std</sub>	X <sub>Sleep Temp</sub>
(Default)		0	0	1	0	0	0	1	0	1	1	0	0
<b>LIMIT Register</b>													
0	0	Lim_min						Lim_max					
0	0	Lim_min5	Lim_min4	Lim_min3	Lim_min2	Lim_min1	Lim_min0	Lim_max5	Lim_max4	Lim_max3	Lim_max2	Lim_max1	Lim_max0
(Default)		0	0	1	1	1	0	0	1	1	0	0	0

**Table 5-3.** Effect of the Configuration Word BR\_Range

BR_Range		Baud Rate Range/Extension Factor for Bit Check Limits (XLim)
Baud1	Baud0	
0	0	BR_Range0 (application USA/Europe: BR_Range0 = 1.0 kBaud to 1.8 kBaud) (Default) XLim = 8 (Default)
0	1	BR_Range1 (application USA/Europe: BR_Range1 = 1.8 kBaud to 3.2 kBaud) XLim = 4
1	0	BR_Range2 (application USA/Europe: BR_Range2 = 3.2 kBaud to 5.6 kBaud) XLim = 2
1	1	BR_Range3 (application USA/Europe: BR_Range3 = 5.6 kBaud to 10 kBaud) XLim = 1

**Table 5-4.** Effect of the Configuration Word  $N_{\text{Bitcheck}}$ 

$N_{\text{Bitcheck}}$		Number of Bits to be Checked
BitChk1	BitChk0	
0	0	0
0	1	3
1	0	6 (Default)
1	1	9

**Table 5-5.** Effect of the Configuration Bit VPOUT

VPOUT	Level of the Multi-purpose Output Port POUT
POUT	
0	0 (Default)
1	1

**Table 5-6.** Effect of the Configuration Word Sleep

Sleep					Start Value for Sleep Counter ( $T_{\text{Sleep}} = \text{Sleep} \times X_{\text{Sleep}} \times 1024 \times T_{\text{CLK}}$ )
Sleep4	Sleep3	Sleep2	Sleep1	Sleep0	
0	0	0	0	0	0 (Receiver is continuously polling until a valid signal occurs)
0	0	0	0	1	1 ( $T_{\text{Sleep}} \approx 2 \text{ ms}$ for $X_{\text{Sleep}} = 1$ in US/European applications)
0	0	0	1	0	2
0	0	0	1	1	3
.	.	.	.	.	.
.	.	.	.	.	.
.	.	.	.	.	.
0	1	0	1	1	11 (USA: $T_{\text{Sleep}} = 22.96 \text{ ms}$ , Europe: $T_{\text{Sleep}} = 23.31 \text{ ms}$ ) (Default)
.	.	.	.	.	.
.	.	.	.	.	.
.	.	.	.	.	.
1	1	1	0	1	29
1	1	1	1	0	30
1	1	1	1	1	31 (Permanent sleep mode)

**Table 5-7.** Effect of the Configuration Word  $X_{Sleep}$ 

$X_{Sleep}$		Extension Factor for Sleep Time ( $T_{Sleep} = Sleep \times X_{Sleep} \times 1024 \times T_{Clk}$ )
$X_{SleepStd}$	$X_{SleepTemp}$	
0	0	1 (Default)
0	1	8 ( $X_{Sleep}$ is reset to 1 if bit check fails once)
1	0	8 ( $X_{Sleep}$ is set permanently)
1	1	8 ( $X_{Sleep}$ is set permanently)

**Table 5-8.** Effect of the Configuration Word  $Lim\_min$ 

$Lim\_min$						Lower Limit Value for Bit Check
$Lim\_min < 10$ is not applicable						$(T_{Lim\_min} = Lim\_min \times X_{Lim} \times T_{Clk})$
0	0	1	0	1	0	10
0	0	1	0	1	1	11
0	0	1	1	0	0	12
0	0	1	1	0	1	13
0	0	1	1	1	0	14 (Default) (USA: $T_{Lim\_min} = 228 \mu s$ , Europe: $T_{Lim\_min} = 232 \mu s$ )
.	.	.	.	.	.	.
.	.	.	.	.	.	.
.	.	.	.	.	.	.
1	1	1	1	0	1	61
1	1	1	1	1	0	62
1	1	1	1	1	1	63

**Table 5-9.** Effect of the Configuration Word  $Lim\_max$ 

$Lim\_max$						Upper Limit Value for Bit Check
$Lim\_max < 12$ is not applicable						$(T_{Lim\_max} = (Lim\_max - 1) \times X_{Lim} \times T_{Clk})$
0	0	1	1	0	0	12
0	0	1	1	0	1	13
0	0	1	1	1	0	14
.	.	.	.	.	.	.
.	.	.	.	.	.	.
.	.	.	.	.	.	.
0	1	1	0	0	0	24 (Default) (USA: $T_{Lim\_max} = 375 \mu s$ , Europe: $T_{Lim\_max} = 381 \mu s$ )
.	.	.	.	.	.	.
.	.	.	.	.	.	.
.	.	.	.	.	.	.
1	1	1	1	0	1	61
1	1	1	1	1	0	62
1	1	1	1	1	1	63

### 5.5.1 Conservation of the Register Information

The ATA3745 has integrated power-on reset and brown-out detection circuitry to provide a mechanism to preserve the RAM register information.

According to [Figure 5-13](#), a power-on reset (POR) is generated if the supply voltage  $V_S$  drops below the threshold voltage  $V_{ThReset}$ . The default parameters are programmed into the configuration registers in that condition. Once  $V_S$  exceeds  $V_{ThReset}$ , the POR is canceled after the minimum reset period  $t_{Rst}$ . A POR is also generated when the supply voltage of the receiver is turned on.

To indicate that condition, the receiver displays a reset marker (RM) at pin DATA after a reset. The RM is represented by the fixed frequency  $f_{RM}$  at a 50% duty cycle. RM can be canceled via an "L" pulse  $t_1$  at pin DATA. The RM implies the following characteristics:

- $f_{RM}$  is lower than the lowest feasible frequency of a data signal. By this means, RM cannot be misinterpreted by the connected microcontroller.
- If the receiver is set back to polling mode via pin DATA, RM cannot be canceled by accident if  $t_1$  is applied according to the proposal in ["Programming the Configuration Register"](#) on [page 22](#).

By means of that mechanism, the receiver cannot lose its register information without communicating that condition via the reset marker RM.

**Figure 5-13.** Generation of the Power-on Reset

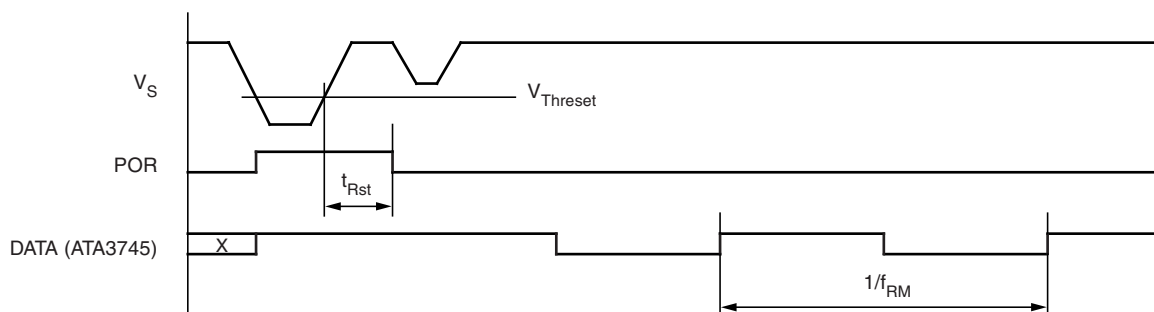

**Figure 5-14.** Timing of the Register Programming

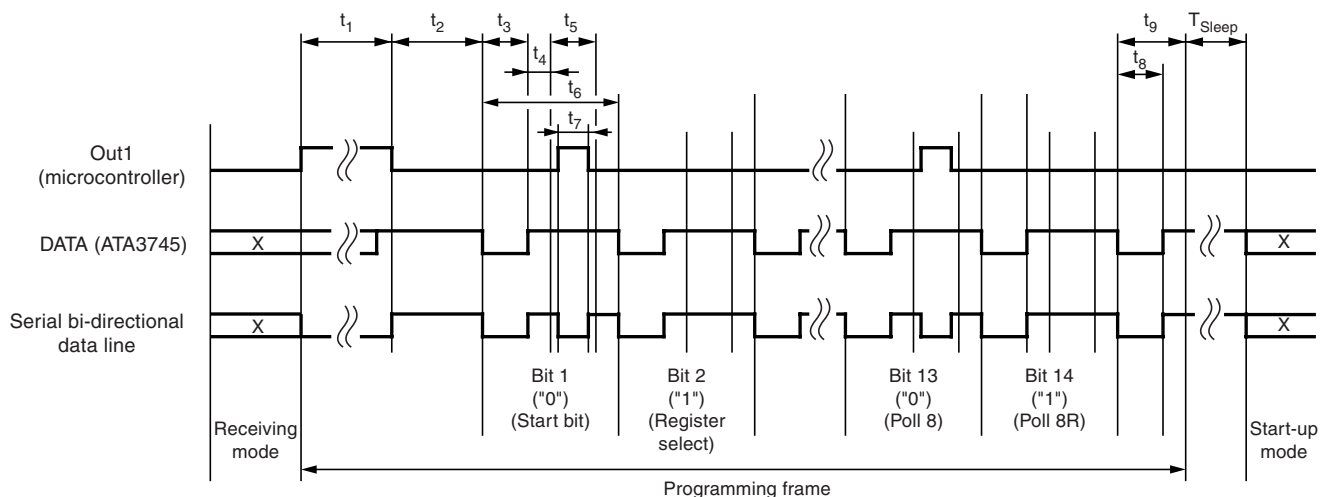

## 5.5.2 Programming the Configuration Register

The configuration registers are programmed serially via the bi-directional data line according to Figure 5-14 on page 21 and Figure 5-15.

**Figure 5-15.** One-wire Connection to a Microcontroller

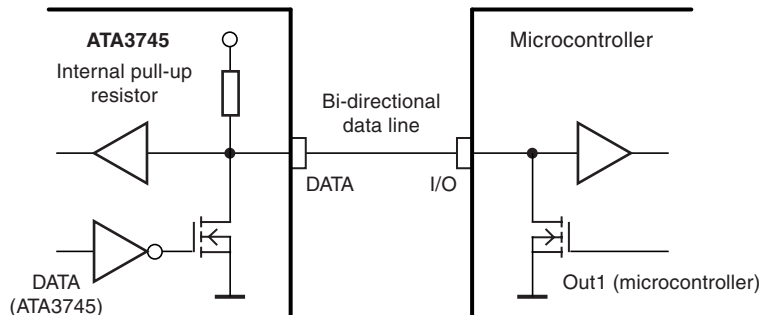

To start programming, the serial data line DATA is pulled by the microcontroller to “L” for the time period  $t_1$ . When DATA has been released, the receiver becomes the master device. When the programming delay period  $t_2$  has elapsed, it emits 14 subsequent synchronization pulses with the pulse length  $t_3$ . After each of these pulses, a programming window occurs. The delay until the program window starts is determined by  $t_4$ , the duration is defined by  $t_5$ . Within the programming window, the individual bits are set. If the microcontroller pulls down pin DATA for the time period  $t_7$  during  $t_5$ , the corresponding bit is set to “0”. If no programming pulse  $t_7$  is issued, this bit is set to “1”. All 14 bits are subsequently programmed in this way. The time frame to program a bit is defined by  $t_6$ .

Bit 14 is followed by the equivalent time window  $t_9$ . During this window, the equivalent acknowledge pulse  $t_8$  (E\_Ack) occurs if the mode word just programmed is equivalent to the mode word that was already stored in that register. E\_Ack should be used to verify that the mode word was correctly transferred to the register. The register must be programmed twice in that case.

Programming of a register is possible both during sleep and active mode of the receiver. During programming, the LNA, LO, low-pass filter, IF amplifier and the demodulator are disabled.

The programming start pulse  $t_1$  initiates the programming of the configuration registers. If bit 1 is set to “1”, it represents the OFF command, setting the receiver back to polling mode at the same time. For the length of the programming start pulse  $t_1$ , the following convention should be considered:

- $t_1(\text{min}) < t_1 < 1535 \times T_{\text{Clk}}$ : [ $t_1(\text{min})$  is the minimum specified value for the relevant BR\_Range]

Programming (or the OFF command) is initiated if the receiver is not in reset mode. If the receiver is in reset mode, programming (or the OFF command) is not initiated, and the reset marker RM is still present at pin DATA. This period is generally used to switch the receiver to polling mode. In a reset condition, RM is not canceled by accident.

- $t_1 > 5632 \times T_{\text{Clk}}$

Programming (or the OFF command) is initiated in any case. RM is cancelled if present. This period is used if the connected microcontroller detected RM. If a configuration register is programmed, this time period for  $t_1$  can generally be used. Note that the capacitive load at pin DATA is limited. The resulting time constant  $t$  together with an optional external pull-up resistor may not be exceeded to ensure proper operation.

## 6. Absolute Maximum Ratings

Stresses beyond those listed under “Absolute Maximum Ratings” may cause permanent damage to the device. This is a stress rating only and functional operation of the device at these or any other conditions beyond those indicated in the operational sections of this specification is not implied. Exposure to absolute maximum rating conditions for extended periods may affect device reliability.

Parameters	Symbol	Min.	Max.	Unit
Supply voltage	$V_S$		6	V
Power dissipation	$P_{tot}$		450	mW
Junction temperature	$T_j$		150	°C
Storage temperature	$T_{stg}$	-55	+125	°C
Ambient temperature	$T_{amb}$	-40	+85	°C
Maximum input level, input matched to 50Ω	$P_{in\_max}$		10	dBm

## 7. Thermal Resistance

Parameters	Symbol	Value	Unit
Junction ambient	$R_{thJA}$	100	K/W

## 8. Electrical Characteristics

All parameters refer to GND,  $V_S = 5V$ ,  $T_{amb} = 25^\circ C$ ,  $f_0 = 433.92$  MHz and  $f_0 = 315$  MHz, unless otherwise specified. The possible operating range refer to different circuit conditions:  $V_S = 4.5V$  to  $5.5V$ ,  $T_{amb} = -40^\circ C$  to  $+85^\circ C$

Parameters	Test Conditions	Symbol	Min.	Typ.	Max.	Unit
Current consumption	Sleep mode (XTO and polling logic active)	$I_{S_{off}}$		190	350	μA
	IC active (startup, bit check, or receiving mode) Pin DATA = H	$I_{S_{on}}$		7.0	8.6	mA
<b>LNA Mixer</b>						
Third-order intercept point	LNA/mixer/IF amplifier input matched according to <a href="#">Figure 3-3 on page 6</a>	IIP3		-28		dBm
LO spurious emission at $RF_{in}$	Input matched according to <a href="#">Figure 3-3 on page 6</a> , required according to I-ETS 300220	$IS_{LORF}$		-73	-57	dBm
Noise figure LNA and mixer (DSB)	Input matching according to <a href="#">Figure 3-3 on page 6</a>	NF		7		dB
LNA_IN input impedance	at 433.92 MHz at 315 MHz	$Z_{i_{LNA\_IN}}$		1.0    1.56 1.3    1.0		kΩ    pF kΩ    pF
1 dB compression point (LNA, mixer, IF amplifier)	Input matched according to <a href="#">Figure 3-3 on page 6</a> , referred to $RF_{in}$	$IP_{1db}$		-40		dBm
Maximum input level	Input matched according to <a href="#">Figure 3-3 on page 6</a> , BER $\leq 10^{-3}$ , ASK mode	$P_{in\_max}$			-23	dBm

## 8. Electrical Characteristics (Continued)

All parameters refer to GND,  $V_S = 5V$ ,  $T_{amb} = 25^\circ C$ ,  $f_0 = 433.92$  MHz and  $f_0 = 315$  MHz, unless otherwise specified. The possible operating range refer to different circuit conditions:  $V_S = 4.5V$  to  $5.5V$ ,  $T_{amb} = -40^\circ C$  to  $+85^\circ C$

Parameters	Test Conditions	Symbol	Min.	Typ.	Max.	Unit
<b>Local Oscillator</b>						
Operating frequency range VCO		$f_{VCO}$	309		439	MHz
Loop bandwidth of the PLL	For best LO noise (design parameter) $R1 = 820\Omega$ $C9 = 4.7$ nF $C10 = 1$ nF	$B_{Loop}$		100		kHz
Capacitive load at pin LF	The capacitive load at pin LF is limited if bit check is used. The limitation therefore also applies to self polling.	$C_{LF\_tot}$			10	nF
XTO operating frequency	XTO crystal frequency, appropriate load capacitance must be connected to XTAL 6.764375 MHz	$f_{XTO}$	6.764375	6.764375	6.764375	MHz
	4.90625 MHz		-50 ppm 4.90625 -50 ppm		+50 ppm 4.90625 +50 ppm	MHz
Series resonance resistor of the crystal	$f_{XTO} = 6.764$ MHz 4.906 MHz	$R_S$			150 220	$\Omega$ $\Omega$
Static capacitance at pin XTO		$C_{XTO}$			6.5	pF
<b>Analog Signal Processing</b>						
Input sensitivity ASK 600-kHz IF filter	Input matched according to <a href="#">Figure 5-1</a> ASK (level of carrier) $BER \leq 10^{-3}$ , $B = 600$ kHz $f_{in} = 433.92$ MHz/315 MHz $T = 25^\circ C$ , $V_S = 5V$ $f_{IF} = 1$ MHz	$P_{Ref\_ASK}$				
	BR_Range0		-106	-110	-113.5	dBm
	BR_Range1		-104.5	-108.5	-112	dBm
	BR_Range2		-104	-108	-111.5	dBm
	BR_Range3		-102	-106	-109.5	dBm
Sensitivity variation ASK for full operating range including IF filter compared to $T_{amb} = 25^\circ C$ , $V_S = 5V$	600-kHz version $f_{in} = 433.92$ MHz/315 MHz $f_{IF} = 0.81$ MHz to 1.19 MHz $f_{IF} = 0.75$ MHz to 1.25 MHz $P_{ASK} = P_{Ref\_ASK} + \Delta P_{Ref}$	$\Delta P_{Ref}$	+3 +5			dB dB
SNR to suppress in-band noise signals	ASK mode	$SNR_{ASK}$		11		dB
Dynamic range RSSI ampl.		$\Delta R_{RSSI}$		60		dB
Lower cut-off frequency of the data filter	$f_{cu\_DF} = \frac{1}{2 \times \pi \times 30k\Omega \times CDEM}$  $CDEM = 33$ nF	$f_{cu\_DF}$	0.11	0.16	0.20	kHz



## 8. Electrical Characteristics (Continued)

All parameters refer to GND,  $V_S = 5V$ ,  $T_{amb} = 25^\circ C$ ,  $f_0 = 433.92\text{ MHz}$  and  $f_0 = 315\text{ MHz}$ , unless otherwise specified. The possible operating range refer to different circuit conditions:  $V_S = 4.5V$  to  $5.5V$ ,  $T_{amb} = -40^\circ C$  to  $+85^\circ C$

Parameters	Test Conditions	Symbol	Min.	Typ.	Max.	Unit
Recommended CDEM for best performance	ASK mode	CDEM				nF
	BR_Range0 (Default)					
	BR_Range1					
	BR_Range2					
	BR_Range3					nF
Maximum edge-to-edge time period of the input data signal for full sensitivity	BR_Range0 (Default)	$t_{ee\_sig}$				$\mu s$
	BR_Range1					
	BR_Range2					
	BR_Range3					
Minimum edge-to-edge time period of the input data signal for full sensitivity	BR_Range0 (Default)	$t_{ee\_sig}$				$\mu s$
	BR_Range1					
	BR_Range2					
	BR_Range3					
Threshold voltage for reset		$V_{ThRESET}$	1.95	2.8	3.75	V
<b>Digital Ports</b>						
Data output - Saturation voltage LOW - Internal pull-up resistor - Maximum time constant - Maximum capacitive load	$I_{OI} = 1\text{ mA}$ $\tau = C_L (R_{PUP} // R_{EXT})$ without external pull-up resistor $R_{EXT} = 5\text{ k}\Omega$	$V_{OI}$ $R_{PUP}$ $\tau$ $C_L$ $C_L$	39	0.08 50	0.3 61	V k $\Omega$ $\mu s$ pF pF
POUT output - Saturation voltage LOW - Saturation voltage HIGH	$I_{POUT} = 1\text{ mA}$ $I_{POUT} = -1\text{ mA}$	$V_{OI}$ $V_{Oh}$	$V_S - 0.3V$	0.08 $V_S - 0.14V$	0.3	V V
ASK input - High-level input voltage	ASK	$V_{Ih}$	$0.8 \times V_S$			V
ENABLE input - Low-level input voltage - High-level input voltage	Idle mode Active mode	$V_{Il}$ $V_{Ih}$	$0.8 \times V_S$		$0.2 \times V_S$	V V
MODE input - Low-level input voltage - High-level input voltage	Division factor = 10 Division factor = 14	$V_{Il}$ $V_{Ih}$	$0.8 \times V_S$		$0.2 \times V_S$	V V
TEST input - Low-level input voltage	Test input must always be set to LOW	$V_{Il}$			$0.2 \times V_S$	V

## 9. Electrical Characteristics

All parameters refer to GND,  $V_S = 5V$ ,  $T_{amb} = 25^\circ C$ ,  $f_0 = 433.92$  MHz and  $f_0 = 315$  MHz, unless otherwise specified. The possible operating range refer to different circuit conditions:  $V_S = 4.5V$  to  $5.5V$ ,  $T_{amb} = -40^\circ C$  to  $+85^\circ C$

Parameter	Test Condition	Symbol	6.76438-Mhz Oscillator (Mode 1)			4.90625-Mhz Oscillator (Mode 0)			Variable Oscillator			Unit
			Min.	Typ.	Max.	Min.	Typ.	Max.	Min.	Typ.	Max.	
<b>Basic Clock Cycle of the Digital Circuitry</b>												
Basic clock cycle	MODE = 0 (USA) MODE = 1 (Europe)	$T_{Clk}$		2.0697			2.0383			$1 / (f_{XTO} / 10)$ $1 / (f_{XTO} / 14)$		$\mu s$ $\mu s$
Extended basic clock cycle	BR_Range0	$T_{XClk}$		16.6			16.3			$8 \times T_{Clk}$		$\mu s$
	BR_Range1			8.3			8.2			$4 \times T_{Clk}$		$\mu s$
	BR_Range2			4.1			4.1			$2 \times T_{Clk}$		$\mu s$
	BR_Range3			2.1			2.0			$1 \times T_{Clk}$		$\mu s$
<b>Polling Mode</b>												
Sleep time	Sleep and $X_{Sleep}$ are defined in the OPMODE register	$T_{Sleep}$		$Sleep \times X_{Sleep} \times 1024 \times 2.0697$			$Sleep \times X_{Sleep} \times 1024 \times 2.0383$			$Sleep \times X_{Sleep} \times 1024 \times T_{Clk}$		ms
Start-up time	BR_Range0	$T_{Startup}$		1855			1827			896.5		$\mu s$
	BR_Range1			1061			1045			512.5		$\mu s$
	BR_Range2			1061			1045			512.5		$\mu s$
	BR_Range3			663			653			$320.5 \times T_{Clk}$		$\mu s$
Time for Bit check	Average bit check time while polling BR_Range0 BR_Range1 BR_Range2 BR_Range3	$T_{Bitcheck}$		0.45			0.47					ms
				0.24			0.26					ms
				0.14			0.16					ms
				0.14			0.15					ms
		Bit check time for a valid input signal $f_{Sig}$ $N_{Bitcheck} = 0$ $N_{Bitcheck} = 3$ $N_{Bitcheck} = 6$ $N_{Bitcheck} = 9$	$T_{Bitcheck}$	$3 / f_{Sig}$ $6 / f_{Sig}$ $9 / f_{Sig}$			$3.5 / f_{Sig}$ $6.5 / f_{Sig}$ $9.5 / f_{Sig}$	$3 / f_{Sig}$ $6 / f_{Sig}$ $9 / f_{Sig}$			$T_{XClk}$	$3.5 / f_{Sig}$ $6.5 / f_{Sig}$ $9.5 / f_{Sig}$
<b>Receiving Mode</b>												
Intermediate frequency	MODE = 0 (USA) MODE = 1 (Europe)	$f_{IF}$		1.0			1.0			$f_{XTO} \times 64 / 314$ $f_{XTO} \times 64 / 432.92$		MHz MHz
Baud rate range	BR_Range0	BR_Range	1.0			1.8	1.0		1.8	$BR\_Range0 \times 2 \text{ ms} / T_{Clk}$ $BR\_Range1 \times 2 \text{ ms} / T_{Clk}$ $BR\_Range2 \times 2 \text{ ms} / T_{Clk}$ $BR\_Range3 \times 2 \text{ ms} / T_{Clk}$		kBaud
	BR_Range1		1.8			3.2	1.8		3.2		kBaud	
	BR_Range2		3.2			5.6	3.2		5.6		kBaud	
	BR_Range3		5.6			10.0	5.6		10.0		kBaud	
Minimum time period between edges at pin DATA (Figure 5-9 on page 16)	BR_Range0	$T_{DATA\_min}$ tmin1 tmin2		149 182			147 179			$9 \times T_{XClk}$ $11 \times T_{XClk}$		$\mu s$ $\mu s$
	BR_Range1			75 91			73 90			$9 \times T_{XClk}$ $11 \times T_{XClk}$		$\mu s$ $\mu s$
	BR_Range2		37.3 45.5			36.7 44.8			$9 \times T_{XClk}$ $11 \times T_{XClk}$		$\mu s$ $\mu s$	
			18.6 22.8			18.3 22.4			$9 \times T_{XClk}$ $11 \times T_{XClk}$		$\mu s$ $\mu s$	
	BR_Range3			2169 1085 542 271			2136 1068 534 267			$131 \times T_{XClk}$ $131 \times T_{XClk}$ $131 \times T_{XClk}$ $131 \times T_{XClk}$		$\mu s$ $\mu s$ $\mu s$ $\mu s$

## 9. Electrical Characteristics

All parameters refer to GND,  $V_S = 5V$ ,  $T_{amb} = 25^\circ C$ ,  $f_0 = 433.92\text{ MHz}$  and  $f_0 = 315\text{ MHz}$ , unless otherwise specified. The possible operating range refer to different circuit conditions:  $V_S = 4.5V$  to  $5.5V$ ,  $T_{amb} = -40^\circ C$  to  $+85^\circ C$

Parameter	Test Condition	Symbol	6.76438-Mhz Oscillator (Mode 1)			4.90625-Mhz Oscillator (Mode 0)			Variable Oscillator			Unit
			Min.	Typ.	Max.	Min.	Typ.	Max.	Min.	Typ.	Max.	
OFF command at pin ENABLE (Figure 5-12 on page 17)		$t_{Doze}$	3.1			3.05			$1.5 \times T_{Clk}$			$\mu s$
<b>Configuration of the Receiver</b>												
Frequency of the reset marker (Figure 5-13 on page 21)		$f_{RM}$		117.9			119.8			$\frac{1}{4096 \times T_{CLK}}$		Hz
Programming start pulse (Figure 5-11 on page 17, Figure 5-14 on page 21)	BR_Range0	$t_1$	2188		3176	2155		3128	$1057 \times T_{Clk}$		$1535 \times T_{Clk}$	$\mu s$
	BR_Range1		1104		3176	1087		3128	$533 \times T_{Clk}$		$1535 \times T_{Clk}$	
	BR_Range2		561		3176	553		3128	$271 \times T_{Clk}$		$1535 \times T_{Clk}$	
	BR_Range3		290		3176	286		3128	$140 \times T_{Clk}$		$1535 \times T_{Clk}$	
	after POR		11656			11479			$5632 \times T_{Clk}$			
Programming delay period (Figure 5-11 on page 17, Figure 5-14 on page 21)		$t_2$	795		798	783		786	$384.5 \times T_{Clk}$		$385.5 \times T_{Clk}$	$\mu s$
Synchron- ization pulse (Figure 5-11 on page 17, Figure 5-14 on page 21)		$t_3$		265			261			$128 \times T_{Clk}$		$\mu s$
Delay until the program window starts (Figure 5-11 on page 17, Figure 5-14 on page 21)		$t_4$		131			129			$63.5 \times T_{Clk}$		$\mu s$
Programming window (Figure 5-11 on page 17, Figure 5-14 on page 21)		$t_5$		530			522			$256 \times T_{Clk}$		$\mu s$
Time frame of a bit (Figure 5-14 on page 21)		$t_6$		1060			1044			$512 \times T_{Clk}$		$\mu s$

## 9. Electrical Characteristics

All parameters refer to GND,  $V_S = 5V$ ,  $T_{amb} = 25^\circ C$ ,  $f_0 = 433.92\text{ MHz}$  and  $f_0 = 315\text{ MHz}$ , unless otherwise specified. The possible operating range refer to different circuit conditions:  $V_S = 4.5V$  to  $5.5V$ ,  $T_{amb} = -40^\circ C$  to  $+85^\circ C$

Parameter	Test Condition	Symbol	6.76438-Mhz Oscillator (Mode 1)			4.90625-Mhz Oscillator (Mode 0)			Variable Oscillator			Unit
			Min.	Typ.	Max.	Min.	Typ.	Max.	Min.	Typ.	Max.	
Programming pulse (Figure 5-11 on page 17, Figure 5-14 on page 21)		t7	133		529	131		521	$64 \times T_{Clk}$		$256 \times T_{Clk}$	$\mu s$
Equivalent acknowledge pulse: E_Ack (Figure 5-14 on page 21)		t8		265			261			$128 \times T_{Clk}$		$\mu s$
Equivalent time window (Figure 5-14 on page 21)		t9		534			526			$258 \times T_{Clk}$		$\mu s$
OFF bit programming window (Figure 5-11 on page 17)		t10		930			916			$449.5 \times T_{Clk}$		$\mu s$

## 10. Ordering Information

Extended Type Number	Package	Remarks
ATA3745P3-TGQY	SO20	Taped and reeled, Pb-free

## 11. Package Information

### Package SO20

Dimensions in mm

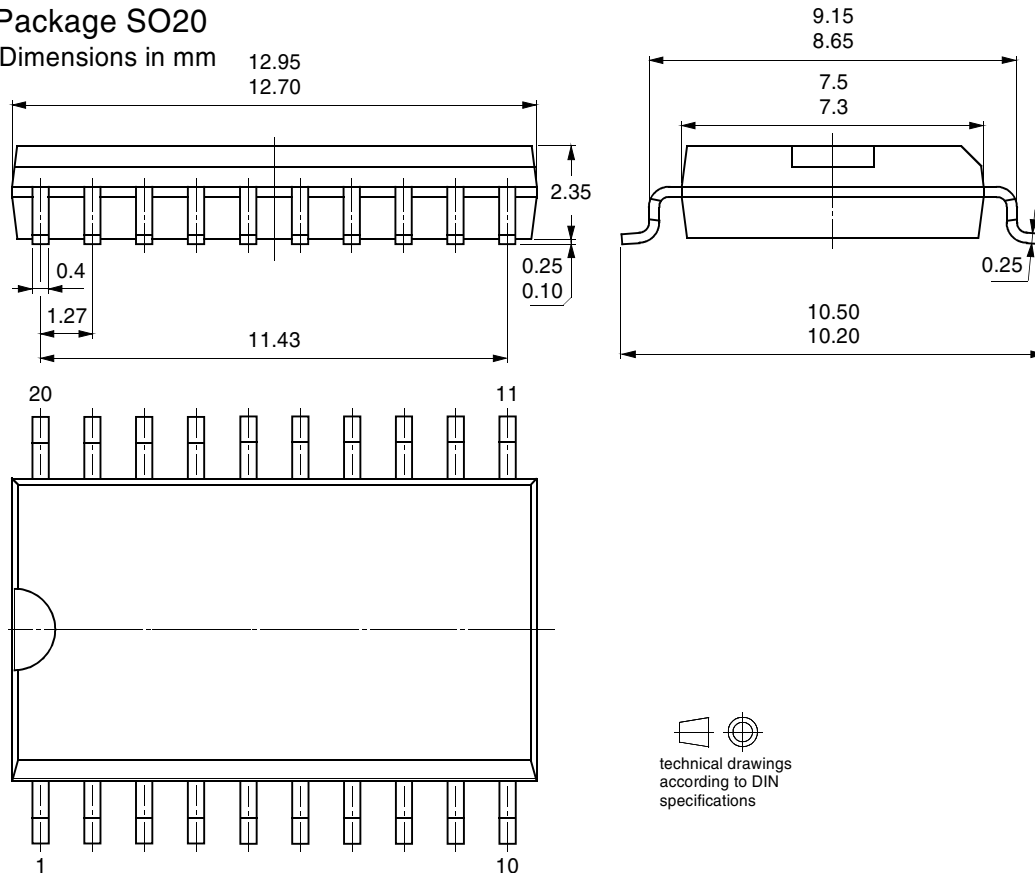

technical drawings  
according to DIN  
specifications

## 12. Revision History

Please note that the following page numbers referred to in this section refer to the specific revision mentioned, not to this document.

Revision No.	History
4901B-RKE-11/07	• Put datasheet in the newest template



## Headquarters

---

**Atmel Corporation**  
2325 Orchard Parkway  
San Jose, CA 95131  
USA  
Tel: 1(408) 441-0311  
Fax: 1(408) 487-2600

## International

---

**Atmel Asia**  
Room 1219  
Chinachem Golden Plaza  
77 Mody Road Tsimshatsui  
East Kowloon  
Hong Kong  
Tel: (852) 2721-9778  
Fax: (852) 2722-1369

**Atmel Europe**  
Le Krebs  
8, Rue Jean-Pierre Timbaud  
BP 309  
78054  
Saint-Quentin-en-Yvelines Cedex  
France  
Tel: (33) 1-30-60-70-00  
Fax: (33) 1-30-60-71-11

**Atmel Japan**  
9F, Tonetsu Shinkawa Bldg.  
1-24-8 Shinkawa  
Chuo-ku, Tokyo 104-0033  
Japan  
Tel: (81) 3-3523-3551  
Fax: (81) 3-3523-7581

## Product Contact

---

**Web Site**  
[www.atmel.com](http://www.atmel.com)

**Technical Support**  
[auto\\_control@atmel.com](mailto:auto_control@atmel.com)

**Sales Contact**  
[www.atmel.com/contacts](http://www.atmel.com/contacts)

**Literature Requests**  
[www.atmel.com/literature](http://www.atmel.com/literature)

---

**Disclaimer:** The information in this document is provided in connection with Atmel products. No license, express or implied, by estoppel or otherwise, to any intellectual property right is granted by this document or in connection with the sale of Atmel products. **EXCEPT AS SET FORTH IN ATMEL'S TERMS AND CONDITIONS OF SALE LOCATED ON ATMEL'S WEB SITE, ATMEL ASSUMES NO LIABILITY WHATSOEVER AND DISCLAIMS ANY EXPRESS, IMPLIED OR STATUTORY WARRANTY RELATING TO ITS PRODUCTS INCLUDING, BUT NOT LIMITED TO, THE IMPLIED WARRANTY OF MERCHANTABILITY, FITNESS FOR A PARTICULAR PURPOSE, OR NON-INFRINGEMENT. IN NO EVENT SHALL ATMEL BE LIABLE FOR ANY DIRECT, INDIRECT, CONSEQUENTIAL, PUNITIVE, SPECIAL OR INCIDENTAL DAMAGES (INCLUDING, WITHOUT LIMITATION, DAMAGES FOR LOSS OF PROFITS, BUSINESS INTERRUPTION, OR LOSS OF INFORMATION) ARISING OUT OF THE USE OR INABILITY TO USE THIS DOCUMENT, EVEN IF ATMEL HAS BEEN ADVISED OF THE POSSIBILITY OF SUCH DAMAGES.** Atmel makes no representations or warranties with respect to the accuracy or completeness of the contents of this document and reserves the right to make changes to specifications and product descriptions at any time without notice. Atmel does not make any commitment to update the information contained herein. Unless specifically provided otherwise, Atmel products are not suitable for, and shall not be used in, automotive applications. Atmel's products are not intended, authorized, or warranted for use as components in applications intended to support or sustain life.

© 2007 Atmel Corporation. All rights reserved. Atmel®, logo and combinations thereof, and others are registered trademarks or trademarks of Atmel Corporation or its subsidiaries. Other terms and product names may be trademarks of others.



Компания «ЭлектроПласт» предлагает заключение долгосрочных отношений при поставках импортных электронных компонентов на взаимовыгодных условиях!

Наши преимущества:

- Оперативные поставки широкого спектра электронных компонентов отечественного и импортного производства напрямую от производителей и с крупнейших мировых складов;
- Поставка более 17-ти миллионов наименований электронных компонентов;
- Поставка сложных, дефицитных, либо снятых с производства позиций;
- Оперативные сроки поставки под заказ (от 5 рабочих дней);
- Экспресс доставка в любую точку России;
- Техническая поддержка проекта, помощь в подборе аналогов, поставка прототипов;
- Система менеджмента качества сертифицирована по Международному стандарту ISO 9001;
- Лицензия ФСБ на осуществление работ с использованием сведений, составляющих государственную тайну;
- Поставка специализированных компонентов (Xilinx, Altera, Analog Devices, Intersil, Interpoint, Microsemi, Aeroflex, Peregrine, Syfer, Eurofarad, Texas Instrument, Miteq, Cobham, E2V, MA-COM, Hittite, Mini-Circuits, General Dynamics и др.);

Помимо этого, одним из направлений компании «ЭлектроПласт» является направление «Источники питания». Мы предлагаем Вам помощь Конструкторского отдела:

- Подбор оптимального решения, техническое обоснование при выборе компонента;
- Подбор аналогов;
- Консультации по применению компонента;
- Поставка образцов и прототипов;
- Техническая поддержка проекта;
- Защита от снятия компонента с производства.



#### Как с нами связаться

**Телефон:** 8 (812) 309 58 32 (многоканальный)

**Факс:** 8 (812) 320-02-42

**Электронная почта:** [org@eplast1.ru](mailto:org@eplast1.ru)

**Адрес:** 198099, г. Санкт-Петербург, ул. Калинина, дом 2, корпус 4, литера А.