

NOTES:

- 1 - SOLDERING INSTRUCTIONS: EXPOSURE TO HIGH TEMPERATURES SHOULD BE KEPT AT A MINIMUM. HONEYWELL RECOMMENDS AN INFRARED REFLOW PROCESS WITH PEAK TEMPERATURES NOT EXCEEDING 245°C FOR 10 SECONDS MAXIMUM. DO NOT WAVE SOLDER THIS PRODUCT, AS THIS PROCESS MAY NEGATIVELY AFFECT THE SENSOR'S PERFORMANCE AND RELIABILITY. SUBJECTING THESE PRODUCTS TO WAVE SOLDERING WILL VOID HONEYWELL'S WARRANTY.
- 2 - ABSOLUTE MAXIMUM RATINGS ARE THE EXTREME LIMITS THE DEVICE WILL MOMENTARILY WITHSTAND WITHOUT DAMAGE TO THE DEVICE. ELECTRICAL AND MAGNETIC CHARACTERISTICS ARE NOT GUARANTEED IF THE SPECIFIED VOLTAGE AND/OR CURRENTS ARE EXCEEDED NOR WILL THE DEVICE NECESSARILY OPERATE AT ABSOLUTE MAXIMUM RATING.
- 3 - THE MAGNETIC FLUX USED TO OPERATE THE SWITCH MUST BE IN BOTH DIRECTION AND LOCATION SHOWN. THIS IS OMNI POLAR DEVICE SENSITIVE TO EITHER POLE.
- 4 - THE MAGNETIC FIELD STRENGTH (GAUSS) REQUIRED TO CAUSE THE SWITCH TO CHANGE STATE (OPERATE AND RELEASE) WILL BE AS SPECIFIED IN THE MAGNETIC CHARACTERISTICS. TO TEST THE SWITCH AGAINST THE SPECIFIED MAGNETIC CHARACTERISTICS, THE SWITCH MUST BE PLACED IN A UNIFORM MAGNETIC FIELD.
- 5 - THIS PRODUCT WILL BE SUPPLIED IN TAPE AND REEL FORM PER EIA STD 481.
- 6 - GATE VESTAGE PERMITTED IN THESE AREAS. UNDERFLUSH BREAKOUT LIMITED TO .007.
- 7 - THESE HALL EFFECT SENSORS MAY HAVE AN INITIAL OUTPUT IN EITHER THE ON OR OFF STATE IF POWERED UP WITH AN APPLIED MAGNETIC FIELD IN THE DIFFERENTIAL ZONE (APPLIED MAGNETIC FIELD > Brp AND < Bop). HONEYWELL RECOMMENDS THAT THE APPLICATION CIRCUIT DESIGNER ALLOW 10 MICROSECONDS AFTER SUPPLY VOLTAGE HAS REACHED Vs FOR THE OUTPUT VOLTAGE TO STABILIZE.

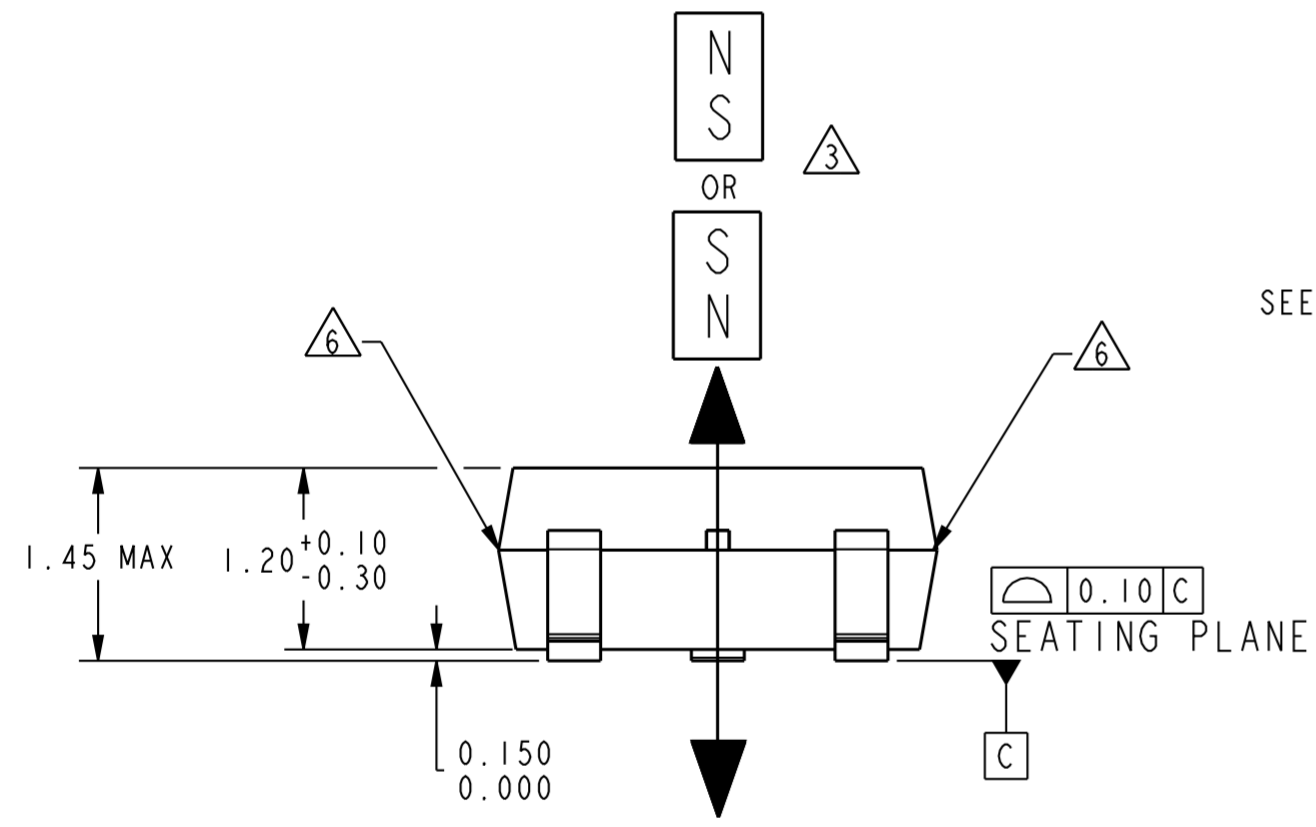

SEE DETAIL A

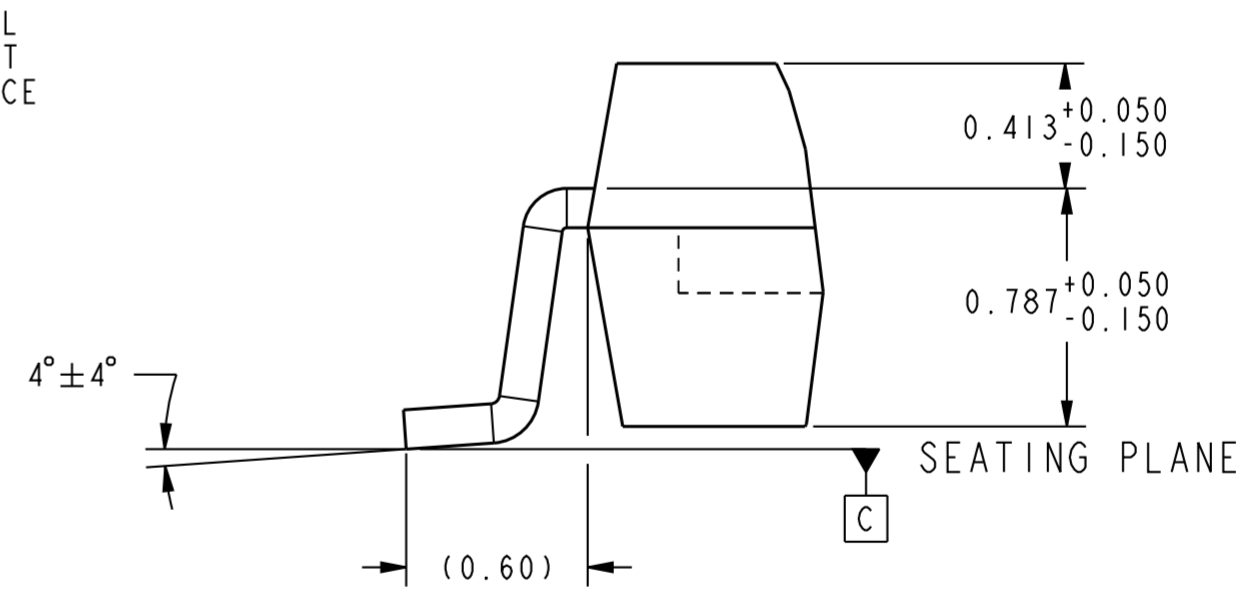
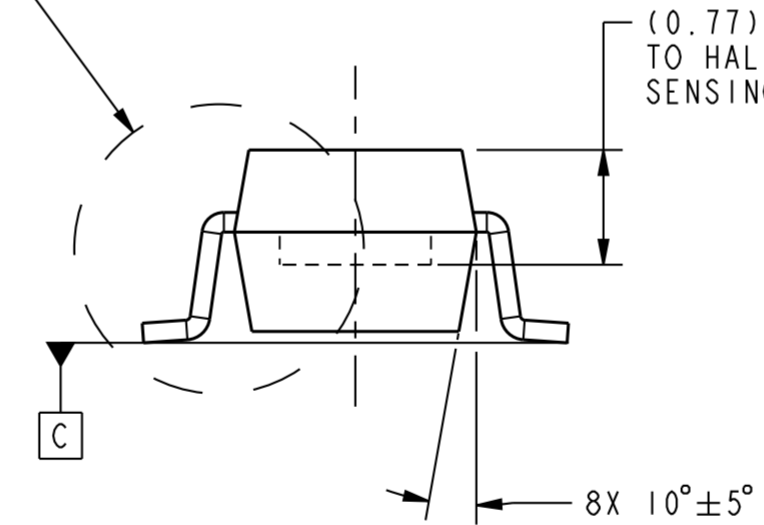

DETAIL A  
SCALE 40:1

1547 LOW POWER HALL SIMPLIFIED BLOCK DIAGRAM

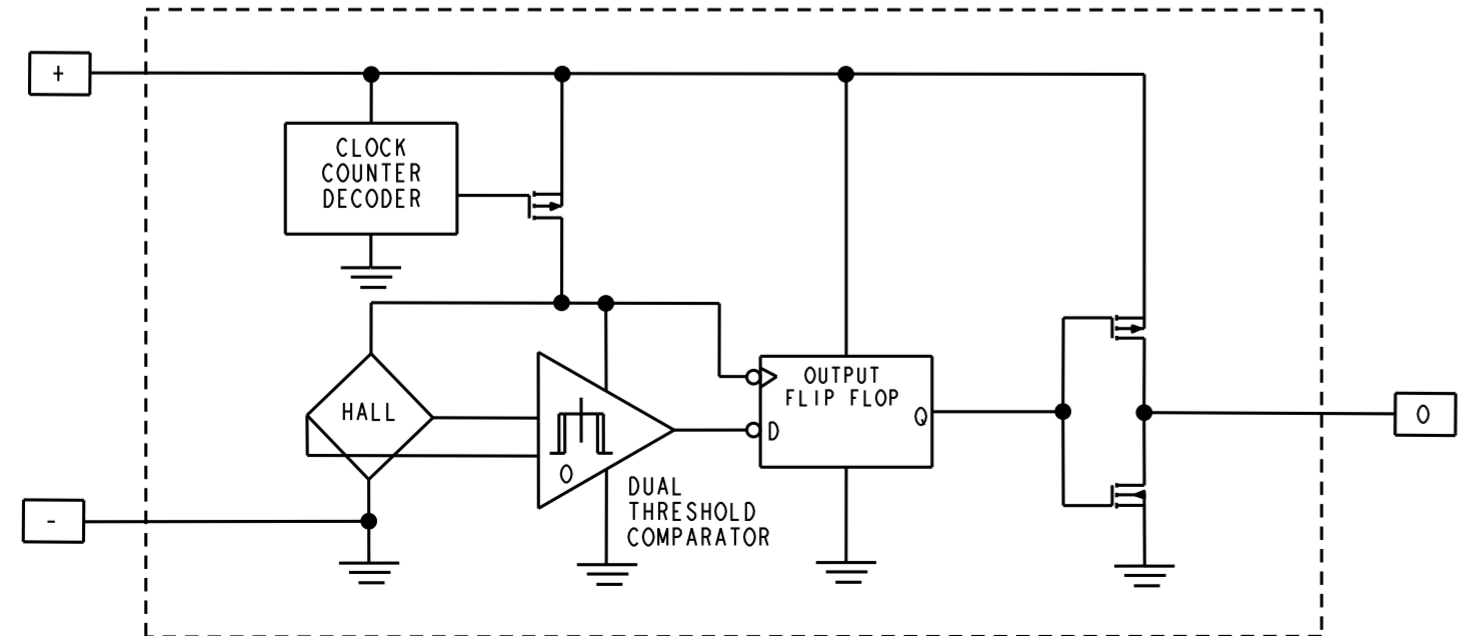

DESIGN UNITS: MM		DRAWN	JLH	23 JUN 10
TOLERANCES UNLESS NOTED:		CHECK	JLH	23 JUN 10
NO PLACES	x ±	THIS DRAWING COVERS A PROPRIETARY ITEM AND IS THE PROPERTY OF HONEYWELL. THIS DRAWING IS NOT TO BE COPIED OR USED WITHOUT THE PERMISSION OF HONEYWELL.		
ONE PLACE	.x ±	INTERPRET PER ASME Y14.5M-1994 OTHER HONEYWELL ENGINEERING STANDARDS MAY APPLY		
TWO PLACE	.xx ±	Pro/ENGINEER 3D		
THREE PLACE	.xxx ±	SCALE NONE		
ANGLES	x ±	SHEET 1 OF 4		

THIRD ANGLE PROJECTION		<b>Honeywell</b>	
		TITLE	
		LOW POWER SOLID STATE SENSOR, IC	
		SIZE	A2
		TYPE	I
		PACKAGE CODE	-
		DRAWING NAME	SL353LT
		REV	C

DESIGN UNITS: MM		DRAWN	JLH	23 JUN 10
TOLERANCES UNLESS NOTED:		CHECK	JLH	23 JUN 10
NO PLACES	x ±	THIS DRAWING COVERS A PROPRIETARY ITEM AND IS THE PROPERTY OF HONEYWELL. THIS DRAWING IS NOT TO BE COPIED OR USED WITHOUT THE PERMISSION OF HONEYWELL.		
ONE PLACE	.x ±	INTERPRET PER ASME Y14.5M-1994 OTHER HONEYWELL ENGINEERING STANDARDS MAY APPLY		
TWO PLACE	.xx ±	Pro/ENGINEER 3D		
THREE PLACE	.xxx ±	SCALE NONE		
ANGLES	x ±	SHEET 1 OF 4		

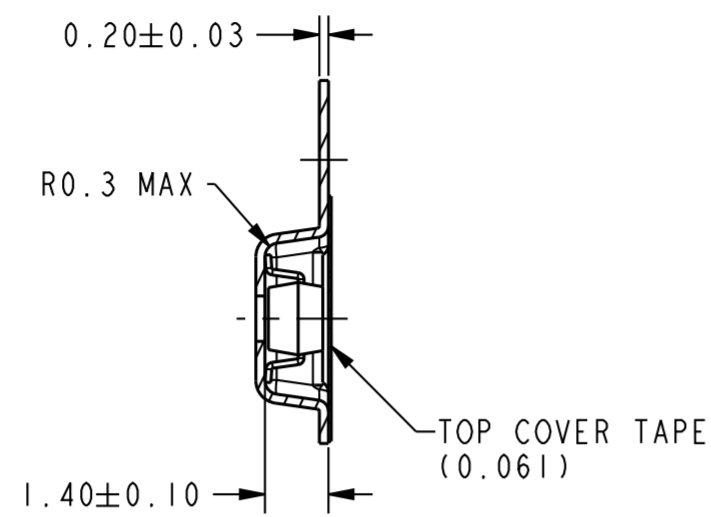

SECTION **B-B**

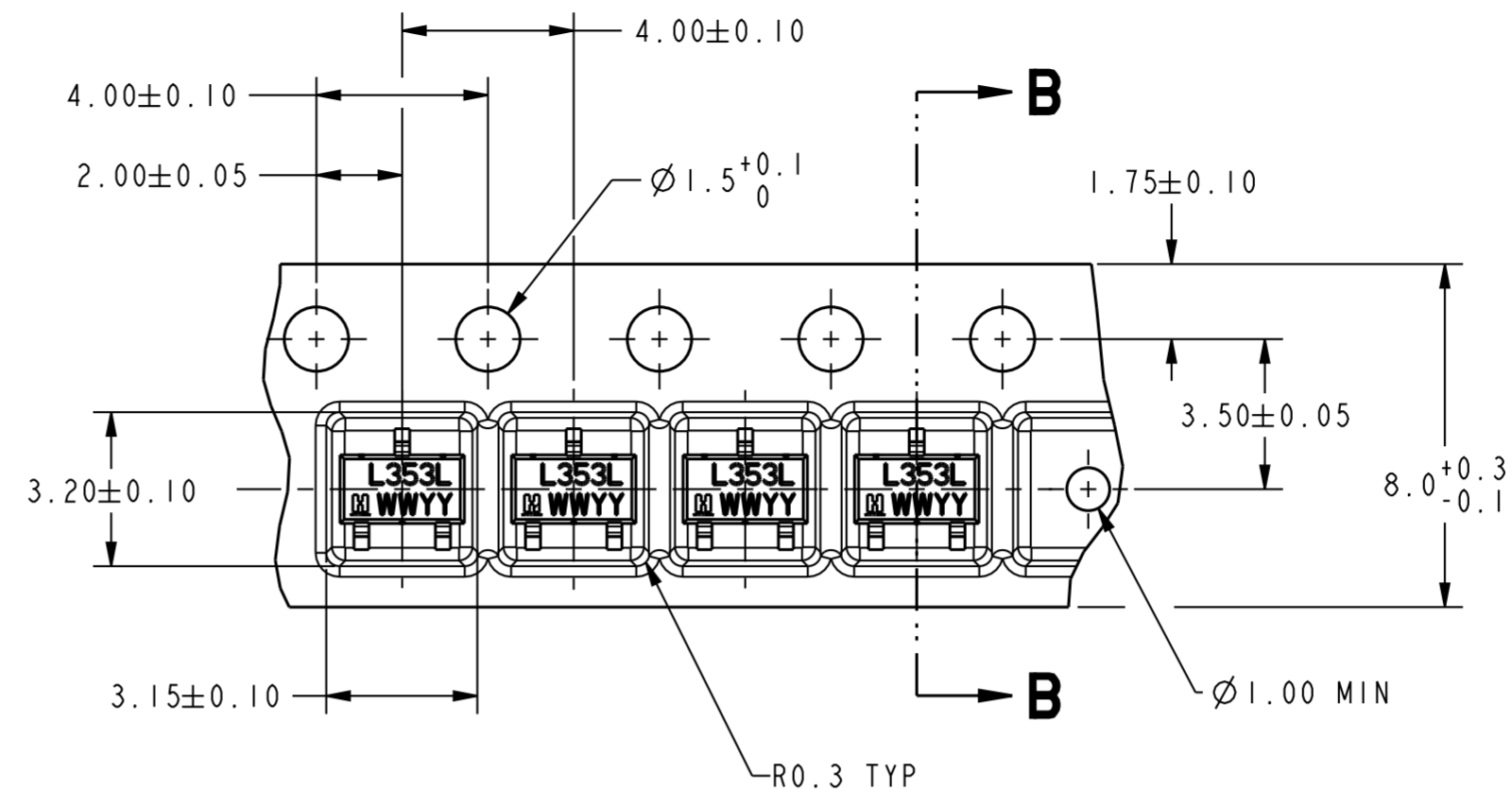

TAPE AND REEL DIMENSIONS 5

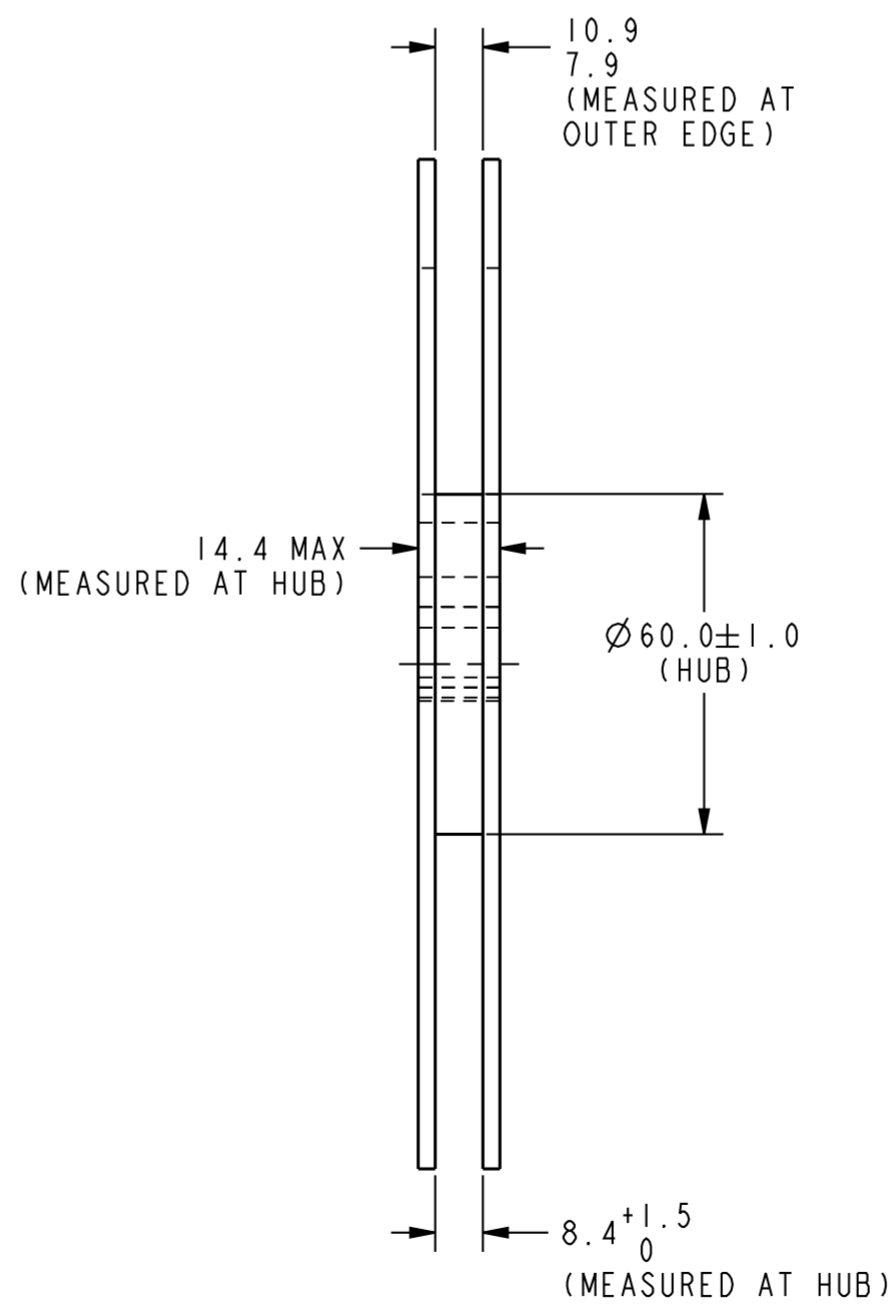
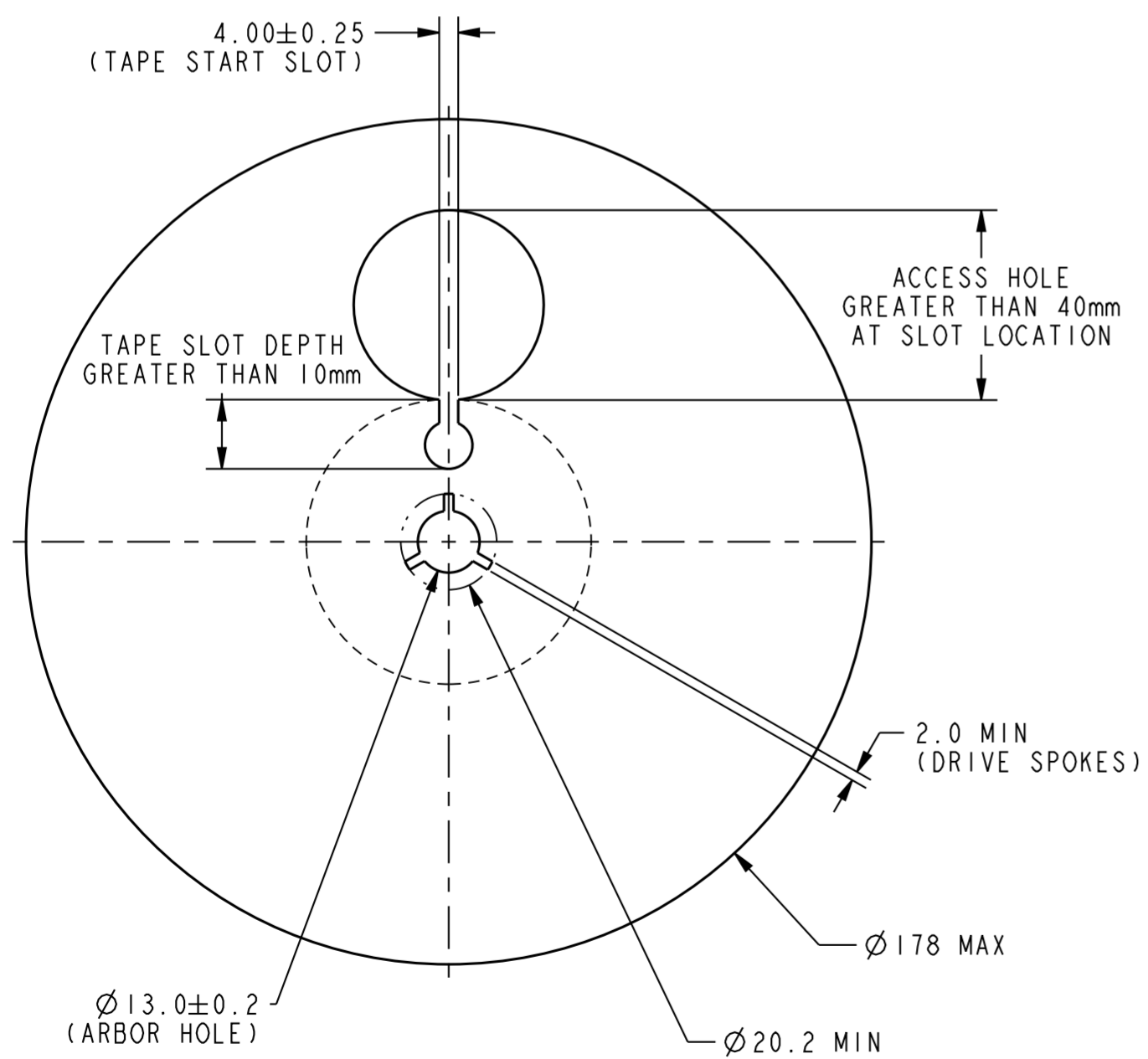

DIRECTION OF FEED FROM REEL



THIS DRAWING COVERS A PROPRIETARY ITEM AND IS THE PROPERTY OF HONEYWELL. THIS DRAWING IS NOT TO BE COPIED OR USED WITHOUT THE PERMISSION OF HONEYWELL.				<b>Honeywell</b>				
				SIZE	TYPE	CAGE CODE	DRAWING NAME	REV
				A2	I	-	SL353LT	C
				SCALE	NONE		SHEET	2 OF 4

**MAGNETIC CHARACTERISTICS (2.2V ≤ V<sub>s</sub> ≤ 5.5V, -40°C ≤ T<sub>a</sub> ≤ 85°C)**

CHARACTERISTICS	CONDITIONS	MIN	TYP	MAX	UNIT
OPERATE (POSITIVE)		20	60	110	GAUSS
OPERATE (NEGATIVE)		-110	-60	-20	GAUSS
RELEASE (POSITIVE)		5	45	95	GAUSS
RELEASE (NEGATIVE)		-95	-45	-5	GAUSS
DIFFERENTIAL		3	15	60	GAUSS

**ELECTRICAL CHARACTERISTICS (2.2V ≤ V<sub>s</sub> ≤ 5.5V, -40°C ≤ T<sub>a</sub> ≤ 85°C UNLESS OTHERWISE SPECIFIED)**

CHARACTERISTIC	CONDITIONS	MIN	TYP	MAX	UNIT
SUPPLY VOLTAGE		2.2	2.8	5.5	VOLTS
ACTIVE MODE CURRENT			2.5	9	mA
SLEEP MODE CURRENT			1.5	8	μA
AVERAGE CURRENT			1.8	9	μA
ACTIVE MODE TIME		3	6	30	μS
PERIOD		20	45	150	mS
DUTY CYCLE		0.005	0.013	0.025	%
V <sub>OL</sub>	LOAD CURRENT = 100μA		0.11	0.25	VOLTS
V <sub>OH</sub>	LOAD CURRENT = 100μA	V <sub>s</sub> - 0.25	V <sub>s</sub> - 0.11		VOLTS
OPERATING TEMPERATURE		-40		85	°C
STORAGE TEMPERATURE		-40		150	°C

**ELECTRICAL CHARACTERISTICS (V<sub>s</sub> = 2.8V, T<sub>a</sub> = 25°C)**

CHARACTERISTIC	CONDITIONS	MIN	TYP	MAX	UNIT
ACTIVE MODE CURRENT			2.5	4	mA
SLEEP MODE CURRENT			1.5	2.5	μA
AVERAGE CURRENT			1.8	3	μA
ACTIVE MODE TIME		3	6	9	μS
PERIOD		30	45	80	mS
DUTY CYCLE		0.01	0.013	0.016	%
V <sub>OL</sub>	LOAD CURRENT = 100μA		0.11	0.15	VOLTS
V <sub>OH</sub>	LOAD CURRENT = 100μA	V <sub>s</sub> - 0.15	V <sub>s</sub> - 0.11		VOLTS

**ABSOLUTE MAXIMUM RATINGS**

CHARACTERISTIC	CONDITIONS	MIN	TYP	MAX	UNIT
SUPPLY VOLTAGE		-0.5		6	VOLTS
OPERATING TEMPERATURE	AMBIENT	-40		150	°C
SOLDERING TEMPERATURE	APPLIED FOR < 10 SECONDS			265	°C
LOAD CURRENT				5	mA

NOTE: "ABSOLUTE MAXIMUM RATINGS" ARE THOSE VALUES BEYOND WHICH THE SAFETY OF THE DEVICE CANNOT BE GUARANTEED. THIS IS A STRESS RATING ONLY AND FUNCTIONAL OPERATION OF THE DEVICE AT THESE OR ANY OTHER CONDITIONS ABOVE THOSE INDICATED IN THE OPERATIONAL SECTIONS OF THIS SPECIFICATION IS NOT IMPLIED. EXPOSURE TO ABSOLUTE MAXIMUM RATINGS FOR EXTENDED PERIODS MAY AFFECT RELIABILITY.



THIS DRAWING COVERS A PROPRIETARY ITEM AND IS THE PROPERTY OF HONEYWELL. THIS DRAWING IS NOT TO BE COPIED OR USED WITHOUT THE PERMISSION OF HONEYWELL.

**Honeywell**

SIZE	TYPE	PACKAGE CODE	DRAWING NAME	REV
A2	I	-	SL353LT	C
SCALE NONE			SHEET 3 OF 4	

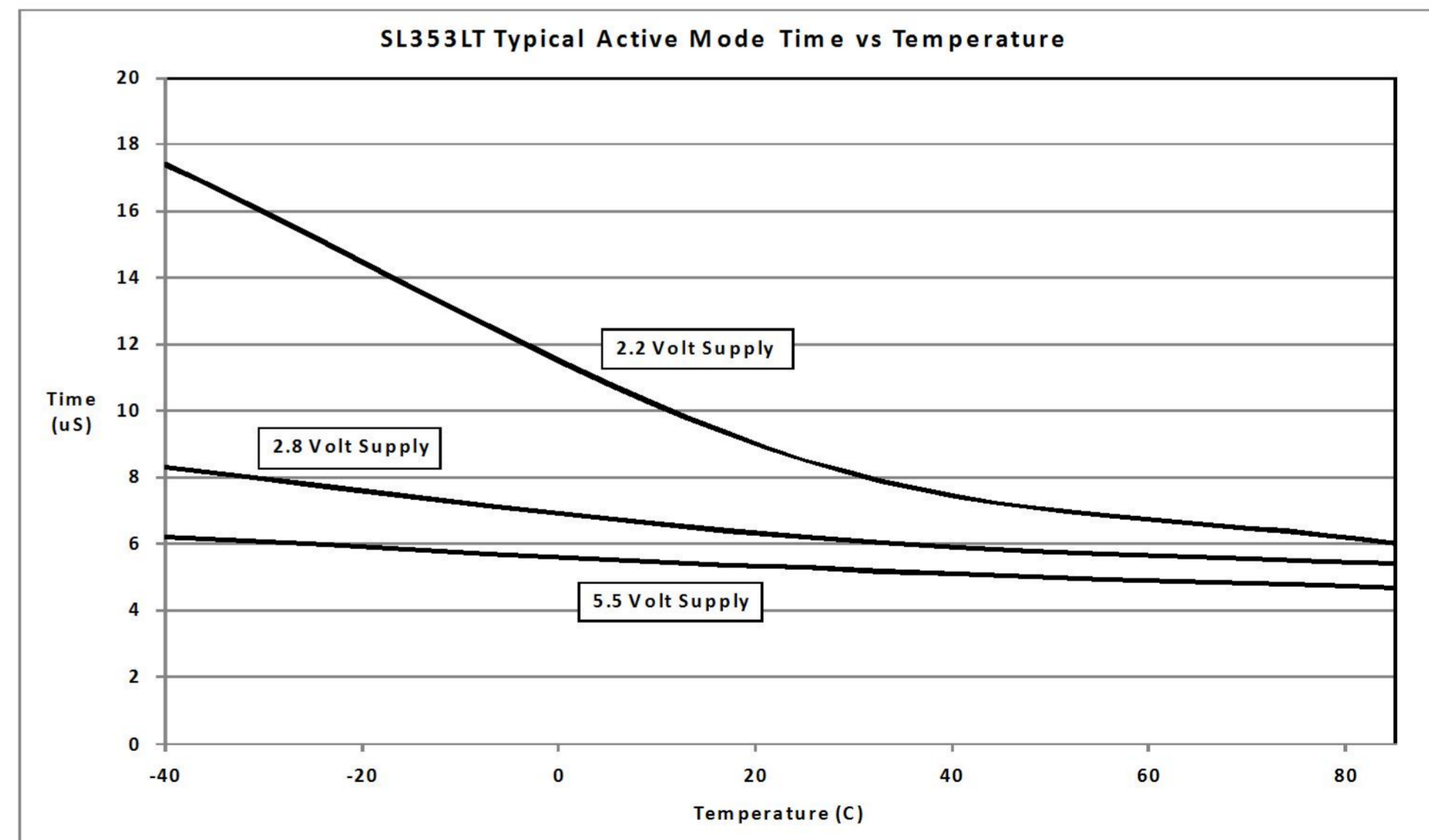
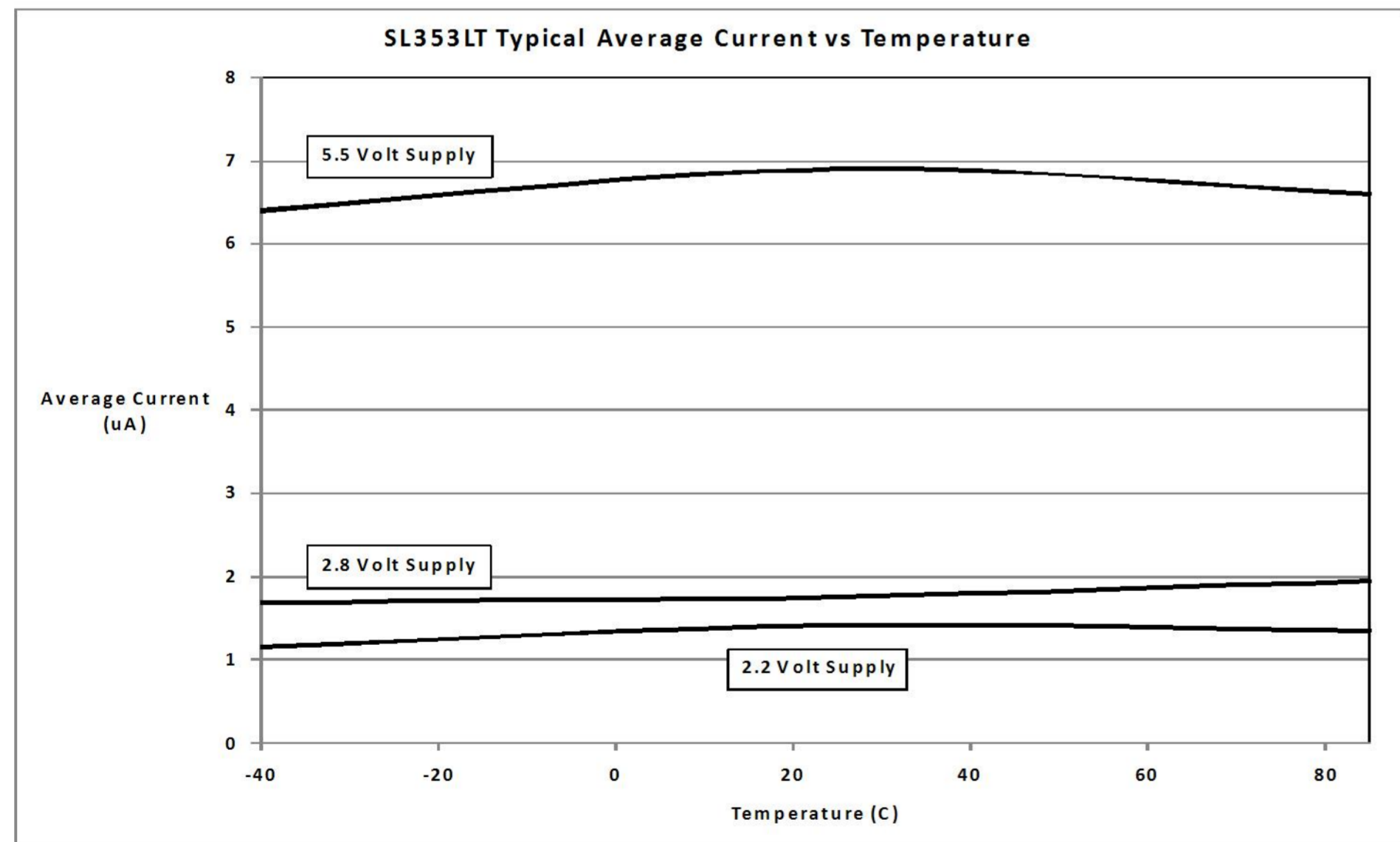
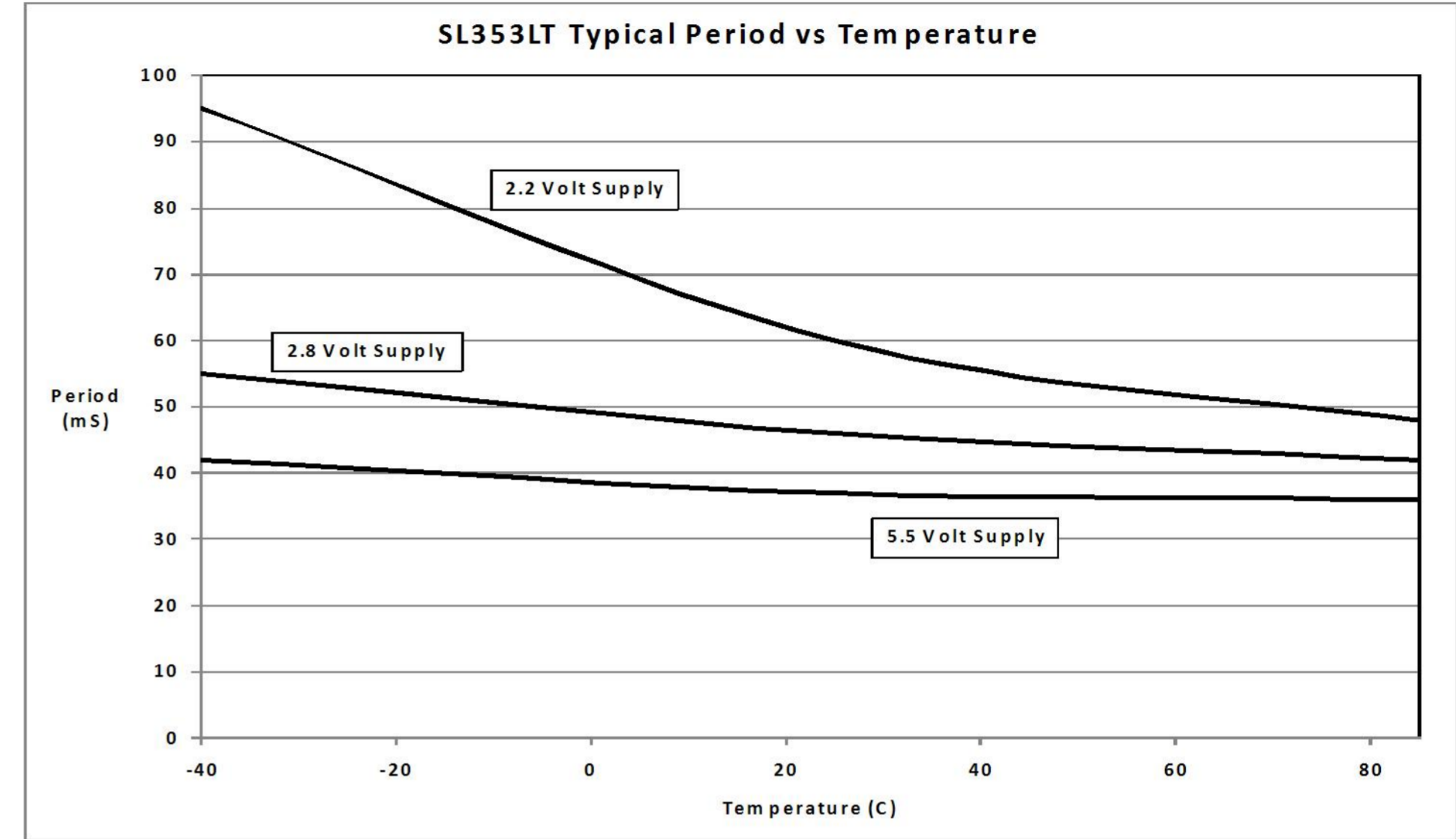
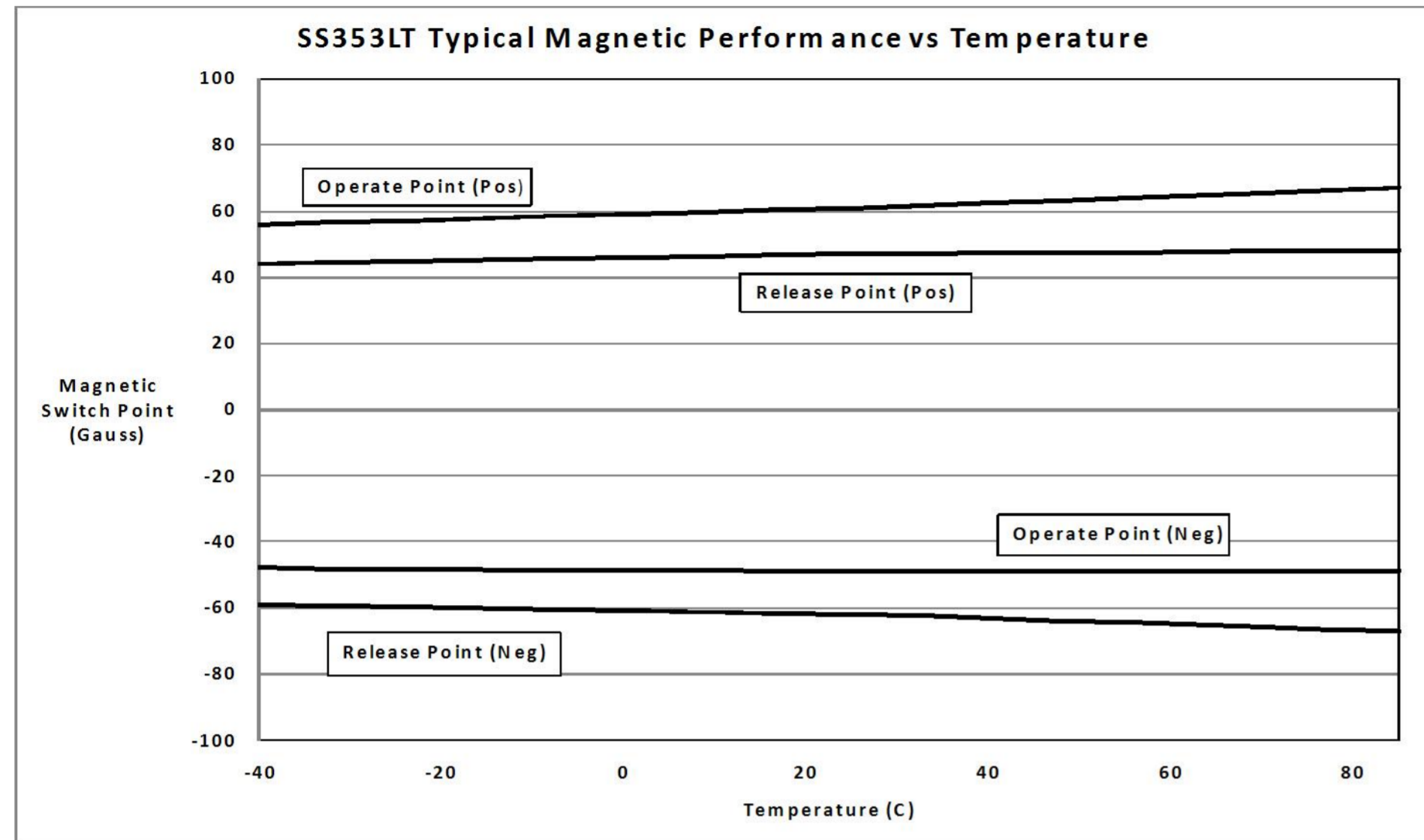

THIS DRAWING COVERS A PROPRIETARY ITEM AND IS THE PROPERTY OF HONEYWELL. THIS DRAWING IS NOT TO BE COPIED OR USED WITHOUT THE PERMISSION OF HONEYWELL.

<b>Honeywell</b>			
SIZE	TYPE	CAGE CODE	DRAWING NAME
A2	I	-	SL353LT
SCALE	NONE	SHEET	4 OF 4
REV	C		



Компания «ЭлектроПласт» предлагает заключение долгосрочных отношений при поставках импортных электронных компонентов на взаимовыгодных условиях!

Наши преимущества:

- Оперативные поставки широкого спектра электронных компонентов отечественного и импортного производства напрямую от производителей и с крупнейших мировых складов;
- Поставка более 17-ти миллионов наименований электронных компонентов;
- Поставка сложных, дефицитных, либо снятых с производства позиций;
- Оперативные сроки поставки под заказ (от 5 рабочих дней);
- Экспресс доставка в любую точку России;
- Техническая поддержка проекта, помощь в подборе аналогов, поставка прототипов;
- Система менеджмента качества сертифицирована по Международному стандарту ISO 9001;
- Лицензия ФСБ на осуществление работ с использованием сведений, составляющих государственную тайну;
- Поставка специализированных компонентов (Xilinx, Altera, Analog Devices, Intersil, Interpoint, Microsemi, Aeroflex, Peregrine, Syfer, Eurofarad, Texas Instrument, Miteq, Cobham, E2V, MA-COM, Hittite, Mini-Circuits, General Dynamics и др.);

Помимо этого, одним из направлений компании «ЭлектроПласт» является направление «Источники питания». Мы предлагаем Вам помощь Конструкторского отдела:

- Подбор оптимального решения, техническое обоснование при выборе компонента;
- Подбор аналогов;
- Консультации по применению компонента;
- Поставка образцов и прототипов;
- Техническая поддержка проекта;
- Защита от снятия компонента с производства.



#### Как с нами связаться

**Телефон:** 8 (812) 309 58 32 (многоканальный)

**Факс:** 8 (812) 320-02-42

**Электронная почта:** [org@eplast1.ru](mailto:org@eplast1.ru)

**Адрес:** 198099, г. Санкт-Петербург, ул. Калинина, дом 2, корпус 4, литера А.