

## Zener Diodes with Surge Current Specification



SMA (DO-214AC)



**RoHS**  
COMPLIANT  
HALOGEN  
**FREE**

### FEATURES

- High reliability
- Stand-off voltage range 8.2 V to 220 V
- Excellent clamping capability
- Fast response time
- AEC-Q101 qualified available
- Base P/N-M3 - halogen-free, RoHS-compliant, and commercial grade
- Base P/NHM3 - halogen-free, RoHS-compliant, and AEC-Q101 qualified
- Material categorization: for definitions of compliance please see [www.vishay.com/doc?99912](http://www.vishay.com/doc?99912)

### APPLICATIONS

- Protection from high voltage, high energy transients

PRIMARY CHARACTERISTICS		
PARAMETER	VALUE	UNIT
V <sub>Z</sub> range nom.	10 to 270	V
Test current I <sub>ZT</sub>	2 to 50	mA
V <sub>BR</sub>	9.4 to 251	V
V <sub>WM</sub>	8.2 to 220	V
P <sub>PPM</sub>	300	W
T <sub>J</sub> max.	150	°C
V <sub>Z</sub> specification	Pulse current	
Circuit configuration	Single	
Polarity	Uni-directional	

ORDERING INFORMATION			
DEVICE NAME	ORDERING CODE	TAPED UNITS PER REEL	MINIMUM ORDER QUANTITY
BZG04-M-series	BZG04xxx-M3-08	1500 per 7" reel	6000/box
BZG04-M-series	BZG04xxx-M3-18	6000 per 13" reel	6000/box
BZG04-M-series	BZG04xxx-HM3-08	1500 per 7" reel	6000/box
BZG04-M-series	BZG04xxx-HM3-18	6000 per 13" reel	6000/box

PACKAGE				
PACKAGE NAME	WEIGHT	MOLDING COMPOUND FLAMMABILITY RATING	MOISTURE SENSITIVITY LEVEL	SOLDERING CONDITIONS
SMA (DO-214AC)	73 mg	UL 94 V-0	MSL level 1 (according J-STD-020)	260 °C/10 s at terminals

ABSOLUTE MAXIMUM RATINGS (T <sub>amb</sub> = 25 °C, unless otherwise specified)				
PARAMETER	TEST CONDITION	SYMBOL	VALUE	UNIT
Power dissipation	R <sub>thJA</sub> < 25 K/W, T <sub>amb</sub> = 100 °C	P <sub>tot</sub>	3000	mW
	R <sub>thJA</sub> < 100 K/W, T <sub>amb</sub> = 50 °C	P <sub>tot</sub>	1250	mW
Non repetitive peak surge power dissipation	t <sub>p</sub> = 10/1000 μs exp. pulse, T <sub>j</sub> = 25 °C prior to surge	P <sub>ZSM</sub>	300	W
Peak forward surge current	10 ms single half sine wave	I <sub>FSM</sub>	50	A
Junction to lead		R <sub>thJL</sub>	25	K/W
Junction to ambient air	Mounted on epoxy-glass hard tissue, fig. 1a	R <sub>thJA</sub>	150	K/W
	Mounted on epoxy-glass hard tissue, fig. 1b	R <sub>thJA</sub>	125	K/W
	Mounted on Al-oxide-ceramic (Al <sub>2</sub> O <sub>3</sub> ), fig. 1b	R <sub>thJA</sub>	100	K/W
Junction temperature		T <sub>j</sub>	150	°C
Storage temperature range		T <sub>stg</sub>	-65 to +150	°C
Forward voltage (max.)	I <sub>F</sub> = 0.5 A	V <sub>F</sub>	1.2	V



<b>ELECTRICAL CHARACTERISTICS</b> ( $T_{amb} = 25\text{ }^{\circ}\text{C}$ , unless otherwise specified)										
PART NUMBER	ZENER VOLTAGE RANGE	TEST CURRENT	STAND OFF VOLTAGE		BREAKDOWN VOLTAGE	CLAMPING VOLTAGE <sup>(1)</sup>		TEMPERATURE COEFFICIENT		JUNCTION CAPACITANCE
	$V_Z$ at $I_{ZT1}$	$I_{ZT1}$	$V_R$ at $I_R$		$V_{(BR)}$ at $I_{ZT1}$	$V_{CL(R)}$ at $I_{PP}$	$I_{PP}$	$TK_{VZ}$ at $I_{ZT1}$		$C_j$ at $V_R = 0\text{ V}$ , $f = 1\text{ MHz}$
	V	mA	V	$\mu\text{A}$	V	V	A	%/K		pF
	NOM.			MAX.	MIN.	MIN.		TYP.	MAX.	TYP.
BZG04-8V2-M	10	50	8.2	20	9.4	14.8	20.3	0.05	0.09	1200
BZG04-9V1-M	11	50	9.1	5	10.4	15.7	19.1	0.05	0.1	1100
BZG04-10-M	12	50	10	5	11.4	17	17.7	0.05	0.1	1000
BZG04-11-M	13	50	11	5	12.4	18.9	15.9	0.05	0.1	850
BZG04-12-M	15	50	12	5	13.8	20.9	14.4	0.05	0.1	815
BZG04-13-M	16	25	13	5	15.3	22.9	13.1	0.06	0.11	785
BZG04-15-M	18	25	15	5	16.8	25.6	11.7	0.06	0.11	710
BZG04-16-M	20	25	16	5	18.8	28.4	10.6	0.06	0.11	655
BZG04-18-M	22	25	18	5	20.8	31	9.7	0.06	0.11	610
BZG04-20-M	24	25	20	5	22.8	33.8	8.9	0.06	0.11	570
BZG04-22-M	27	25	22	5	25.1	38.1	7.9	0.06	0.11	545
BZG04-24-M	30	25	24	5	28	42.2	7.1	0.06	0.11	505
BZG04-27-M	33	25	27	5	31	46.2	6.5	0.06	0.11	475
BZG04-30-M	36	10	30	5	34	50.1	6	0.06	0.11	450
BZG04-33-M	39	10	33	5	37	54.1	5.5	0.06	0.11	420
BZG04-36-M	43	10	36	5	40	60.7	4.9	0.07	0.12	390
BZG04-39-M	47	10	39	5	44	65.5	4.6	0.07	0.12	370
BZG04-43-M	51	10	43	5	48	70.8	4.2	0.07	0.12	350
BZG04-47-M	56	10	47	5	52	78.6	3.8	0.07	0.12	330
BZG04-51-M	62	10	51	5	58	86.5	3.5	0.08	0.13	310
BZG04-56-M	68	10	56	5	64	94.4	3.2	0.08	0.13	291
BZG04-62-M	75	10	62	5	70	103.5	2.9	0.08	0.13	280
BZG04-68-M	82	10	68	5	77	114	2.6	0.08	0.13	275
BZG04-75-M	91	5	75	5	85	126	2.4	0.09	0.13	260
BZG04-82-M	100	5	82	5	94	139	2.2	0.09	0.13	250
BZG04-91-M	110	5	91	5	104	152	2	0.09	0.13	243
BZG04-100-M	120	5	100	5	114	167	1.8	0.09	0.13	170
BZG04-110-M	130	5	110	5	124	185	1.6	0.09	0.13	153
BZG04-120-M	150	5	120	5	138	204	1.5	0.09	0.13	150
BZG04-130-M	160	5	130	5	153	224	1.3	0.09	0.13	145
BZG04-150-M	180	5	150	5	168	249	1.2	0.09	0.13	140
BZG04-160-M	200	5	160	5	188	276	1.1	0.09	0.13	135
BZG04-180-M	220	2	180	5	208	305	1	0.09	0.13	131
BZG04-200-M	240	2	200	5	228	336	0.9	0.09	0.13	122
BZG04-220-M	270	2	220	5	251	380	0.8	0.09	0.13	120

**Note**

<sup>(1)</sup> 10/1000  $\mu\text{s}$  pulse

**BASIC CHARACTERISTICS** ( $T_{amb} = 25\text{ }^{\circ}\text{C}$ , unless otherwise specified)

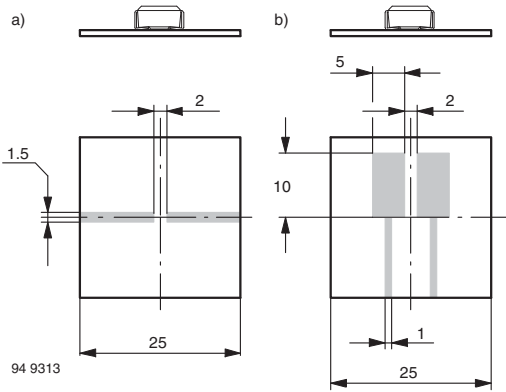

Fig. 1 - Boards for  $R_{thJA}$  Definition (Copper Overlay 35  $\mu$ )



Fig. 3 - Forward Current vs. Forward Voltage

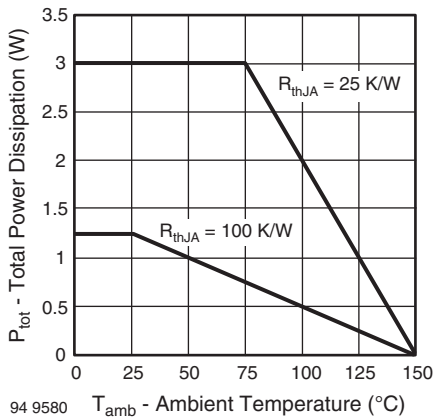

Fig. 2 - Typ. Total Power Dissipation vs. Ambient Temperature

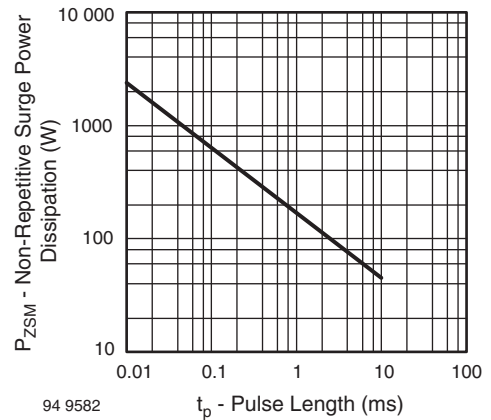

Fig. 4 - Non Repetitive Surge Power Dissipation vs. Pulse Length

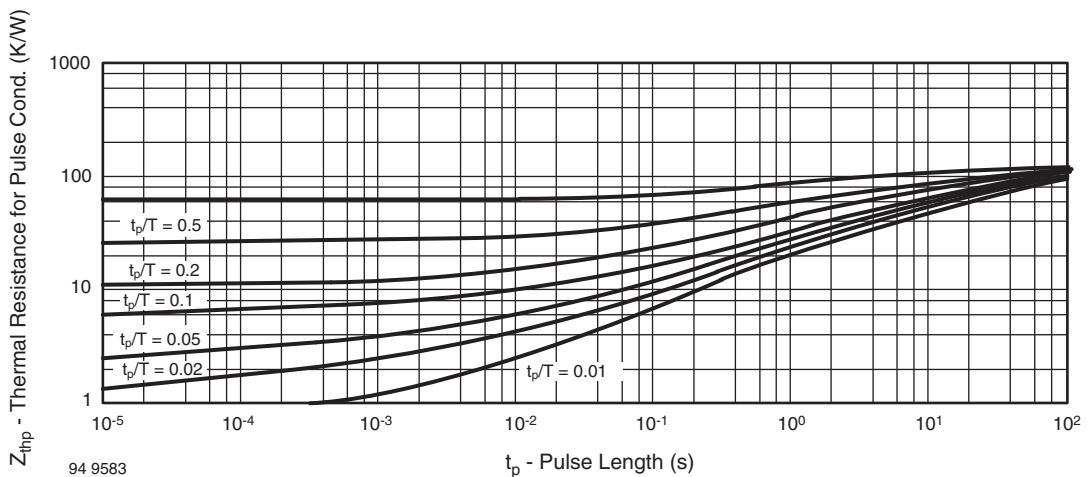
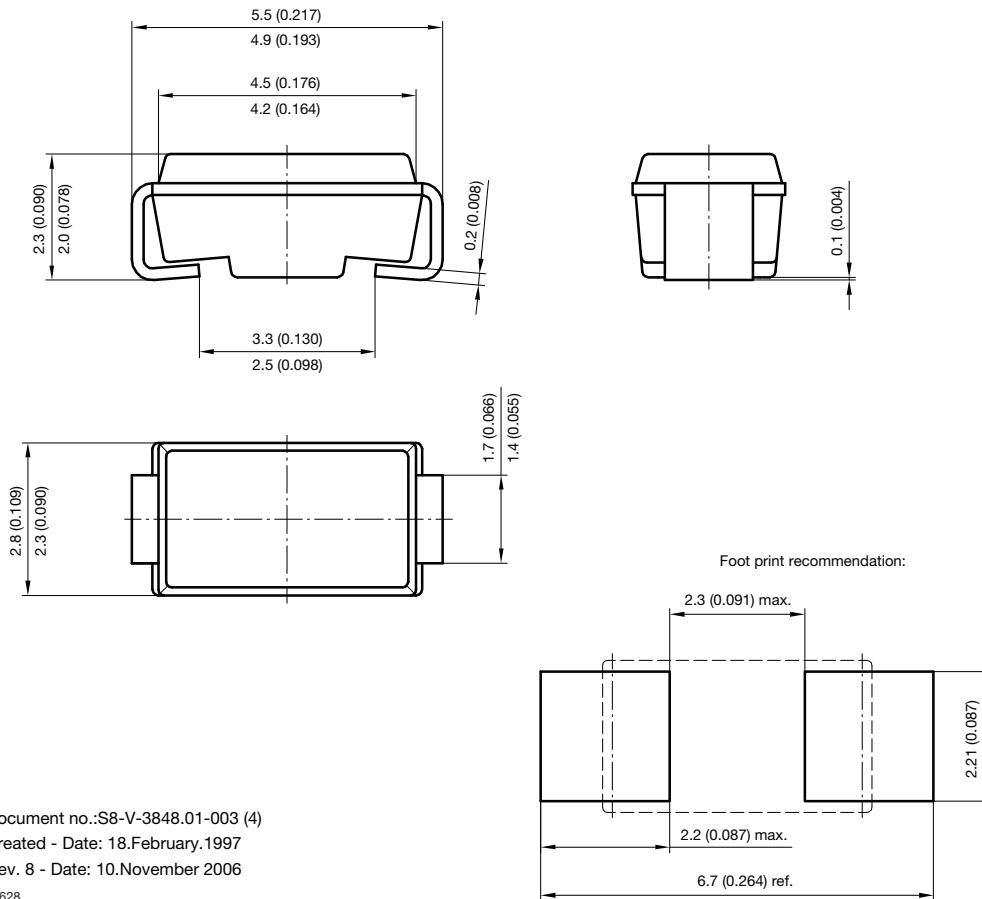

Fig. 5 - Thermal Response



**PACKAGE DIMENSIONS** in millimeters (inches): **SMA (DO-214AC)**



Document no.:S8-V-3848.01-003 (4)  
Created - Date: 18.February.1997  
Rev. 8 - Date: 10.November 2006  
19628



## **Disclaimer**

ALL PRODUCT, PRODUCT SPECIFICATIONS AND DATA ARE SUBJECT TO CHANGE WITHOUT NOTICE TO IMPROVE RELIABILITY, FUNCTION OR DESIGN OR OTHERWISE.

Vishay Intertechnology, Inc., its affiliates, agents, and employees, and all persons acting on its or their behalf (collectively, "Vishay"), disclaim any and all liability for any errors, inaccuracies or incompleteness contained in any datasheet or in any other disclosure relating to any product.

Vishay makes no warranty, representation or guarantee regarding the suitability of the products for any particular purpose or the continuing production of any product. To the maximum extent permitted by applicable law, Vishay disclaims (i) any and all liability arising out of the application or use of any product, (ii) any and all liability, including without limitation special, consequential or incidental damages, and (iii) any and all implied warranties, including warranties of fitness for particular purpose, non-infringement and merchantability.

Statements regarding the suitability of products for certain types of applications are based on Vishay's knowledge of typical requirements that are often placed on Vishay products in generic applications. Such statements are not binding statements about the suitability of products for a particular application. It is the customer's responsibility to validate that a particular product with the properties described in the product specification is suitable for use in a particular application. Parameters provided in datasheets and / or specifications may vary in different applications and performance may vary over time. All operating parameters, including typical parameters, must be validated for each customer application by the customer's technical experts. Product specifications do not expand or otherwise modify Vishay's terms and conditions of purchase, including but not limited to the warranty expressed therein.

Except as expressly indicated in writing, Vishay products are not designed for use in medical, life-saving, or life-sustaining applications or for any other application in which the failure of the Vishay product could result in personal injury or death. Customers using or selling Vishay products not expressly indicated for use in such applications do so at their own risk. Please contact authorized Vishay personnel to obtain written terms and conditions regarding products designed for such applications.

No license, express or implied, by estoppel or otherwise, to any intellectual property rights is granted by this document or by any conduct of Vishay. Product names and markings noted herein may be trademarks of their respective owners.



Компания «ЭлектроПласт» предлагает заключение долгосрочных отношений при поставках импортных электронных компонентов на взаимовыгодных условиях!

Наши преимущества:

- Оперативные поставки широкого спектра электронных компонентов отечественного и импортного производства напрямую от производителей и с крупнейших мировых складов;
- Поставка более 17-ти миллионов наименований электронных компонентов;
- Поставка сложных, дефицитных, либо снятых с производства позиций;
- Оперативные сроки поставки под заказ (от 5 рабочих дней);
- Экспресс доставка в любую точку России;
- Техническая поддержка проекта, помощь в подборе аналогов, поставка прототипов;
- Система менеджмента качества сертифицирована по Международному стандарту ISO 9001;
- Лицензия ФСБ на осуществление работ с использованием сведений, составляющих государственную тайну;
- Поставка специализированных компонентов (Xilinx, Altera, Analog Devices, Intersil, Interpoint, Microsemi, Aeroflex, Peregrine, Syfer, Eurofarad, Texas Instrument, Miteq, Cobham, E2V, MA-COM, Hittite, Mini-Circuits, General Dynamics и др.);

Помимо этого, одним из направлений компании «ЭлектроПласт» является направление «Источники питания». Мы предлагаем Вам помощь Конструкторского отдела:

- Подбор оптимального решения, техническое обоснование при выборе компонента;
- Подбор аналогов;
- Консультации по применению компонента;
- Поставка образцов и прототипов;
- Техническая поддержка проекта;
- Защита от снятия компонента с производства.



#### Как с нами связаться

**Телефон:** 8 (812) 309 58 32 (многоканальный)

**Факс:** 8 (812) 320-02-42

**Электронная почта:** [org@eplast1.ru](mailto:org@eplast1.ru)

**Адрес:** 198099, г. Санкт-Петербург, ул. Калинина, дом 2, корпус 4, литера А.