

High Frequency Programmable PECL Clock Generator

Features

- Jitter peak-peak (Typical) = 35 ps
- LVPECL output
- Default Select option
- Serially configurable multiply ratios
- Output edge rate control
- 16-pin TSSOP
- High frequency
- 3.3 V operation

Benefits

- High accuracy clock generation
 - One pair of differential output drivers
 - Phase-locked loop (PLL) multiplier select
 - 8-bit feedback counter and 6-bit reference counter for high accuracy
 - Minimize electromagnetic interference (EMI)
 - Industry standard, low cost package saves on board space
- For a complete list of related documentation, click [here](#).

Logic Block Diagram

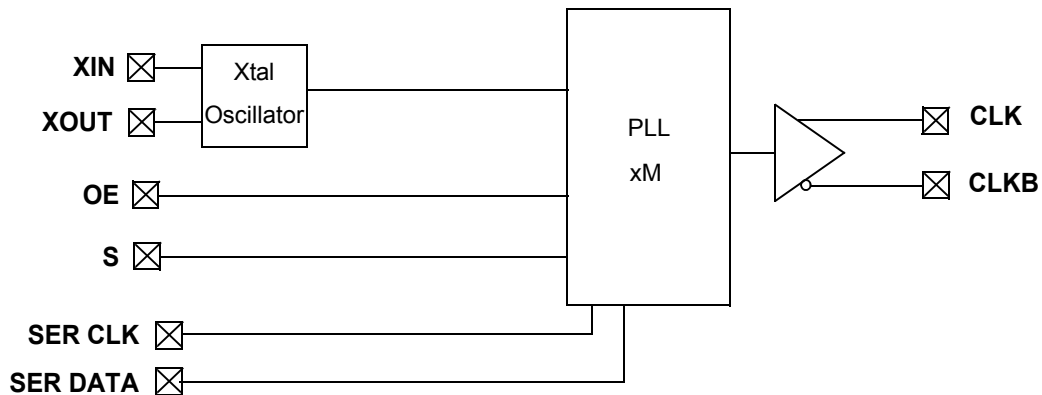

Contents

Pinouts	3	Select Input	8
Pin Definitions	3	PECL Clock Output Driver	8
Frequency Table	3	Signal Waveforms	9
CY2213 Two-Wire Serial Interface	4	Jitter	10
Introduction	4	Ordering Information	12
Serial Interface Specifications	4	Ordering Code Definitions	12
Serial Interface Format	4	Package Diagrams	13
Serial Interface Transfer Format	4	Acronyms	14
Absolute Maximum Conditions	6	Document Conventions	14
Crystal Requirements	6	Units of Measure	14
Electrical Characteristics	6	Document History Page	15
DC Electrical Specifications	6	Sales, Solutions, and Legal Information	16
3.3 V DC Device Characteristics	6	Worldwide Sales and Design Support	16
AC Electrical Specifications	7	Products	16
AC Device Characteristics	7	PSoC® Solutions	16
State Transition Characteristics	8	Cypress Developer Community	16
Functional Specifications	8	Technical Support	16
Crystal Input	8		

Pinouts

Figure 1. 16-pin TSSOP pinout

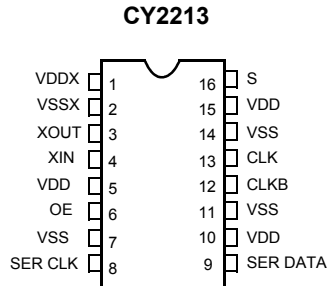

Pin Definitions

Pin Name	Pin Number	Pin Description
VDDX	1	3.3 V Power Supply for Crystal Driver
VSSX	2	Ground for Crystal Driver
XOUT	3	Reference Crystal Feedback
XIN	4	Reference Crystal Input
VDD	5	3.3 V Power Supply (all V _{DD} pins must be tied directly on board)
OE	6	Output Enable, 0 = output disable, 1 = output enable (no internal pull up)
VSS	7	Ground
SER CLK	8	Serial Interface Clock
SER DATA	9	Serial Interface Data
VDD	10	3.3 V Power Supply (all V _{DD} pins must be tied directly on board)
VSS	11	Ground
CLKB	12	LVPECL Output Clock (complement)
CLK	13	LVPECL Output Clock
VSS	14	Ground
VDD	15	3.3 V Power Supply (all V _{DD} pins must be tied directly on board)
S	16	PLL Multiplier Select Input, Pull up Resistor Internal

Frequency Table

S	M (PLL Multiplier)	Example Input Crystal Frequency	CLK, CLKB
0	× 16	25 MHz	400 MHz
1	× 8	15.625 MHz	125 MHz

CY2213 Two-Wire Serial Interface

Introduction

The CY2213 has a two-wire serial interface designed for data transfer operations, and is used for programming the P and Q values for frequency generation. S_{clk} is the serial clock line controlled by the master device. S_{data} is a serial bidirectional data line. The CY2213 is a slave device and can either read or write information on the dataline upon request from the master device.

Figure 2 shows the basic bus connections between master and slave device. The buses are shared by a number of devices and are pulled high by a pull up resistor.

Serial Interface Specifications

Figure 3 shows the Basic Transmission Specification. To begin and end a transmission, the master device generates a start signal (S) and a stop signal (P). Start (S) is defined as switching the S_{data} from HIGH to LOW while the S_{clk} is at HIGH. Similarly, stop (P) is defined as switching the S_{data} from LOW to HIGH while holding the S_{clk} HIGH. Between these two signals, data on S_{data} is synchronous with the clock on the S_{clk} . Data is allowed to change only at LOW period of clock, and must be stable at the

HIGH period of clock. To acknowledge, drive the S_{data} LOW before the S_{clk} rising edge and hold it LOW until the S_{clk} falling edge.

Serial Interface Format

Each slave carries an address. The data transfer is initiated by a start signal (S). Each transfer segment is 1 byte in length. The slave address and the read/write bit are first sent from the master device after the start signal. The addressed slave device must acknowledge (Ack) the master device. Depending on the Read/Write bit, the master device either writes data into (logic 0) or reads data (logic 1) from the slave device. Each time a byte of data is successfully transferred, the receiving device must acknowledge. At the end of the transfer, the master device generates a stop signal (P).

Serial Interface Transfer Format

Figure 3 shows the serial interface transfer format used with the CY2213. Two dummy bytes must be transferred before the first data byte. The CY2213 has only three bytes of latches to store information, and the third byte of data is reserved. Extra data is ignored.

Figure 2. Device Connections

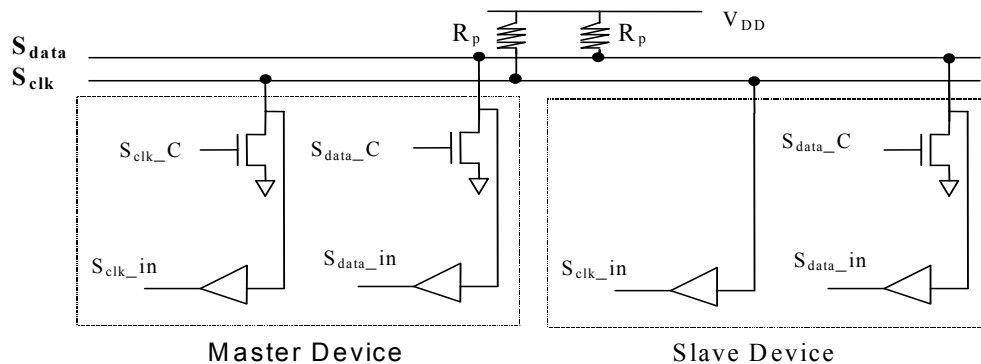

Figure 3. Serial Interface Specifications

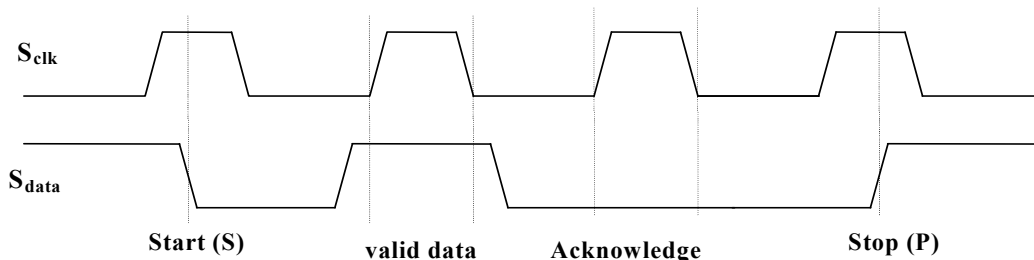
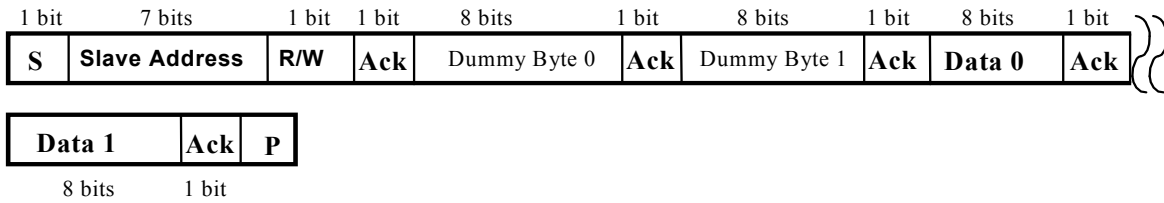

Figure 4. CY2213 Transfer Format

Table 1. Serial Interface Address for the CY2213

A6	A5	A4	A3	A2	A1	A0	R/W
1	1	0	0	1	0	1	0

Table 2. Serial Interface Programming for the CY2213

	b7	b6	b5	b4	b3	b2	b1	b0
Data0	QCNTBYP	SELPQ	Q<5>	Q<4>	Q<3>	Q<2>	Q<1>	Q<0>
Data1	P<7>	P<6>	P<5>	P<4>	P<3>	P<2>	P<1>	P<0>
Data2	Reserved	Reserved	Reserved	Reserved	Reserved	Reserved	Reserved	Reserved

To program the CY2213 using the two-wire serial interface, set the SELPQ bit HIGH. The default setting of this bit is LOW. The P and Q values are determined by the following formulas:

$$P_{\text{final}} = (P_{7..0} + 3) \times 2$$

$$Q_{\text{final}} = Q_{5..0} + 2.$$

If the QCNTBYP bit is set HIGH, then Q_{final} defaults to a value of 1. The default setting of this bit is LOW.

If the SELPQ bit is set LOW, the PLL multipliers are set using the values in the Select Function Table.

CyberClocks™ has been developed to generate P and Q values for stable PLL operation. This software is downloadable from www.cypress.com

$$\text{PLL Frequency} = \text{Reference} \times P/Q = \text{Output}$$

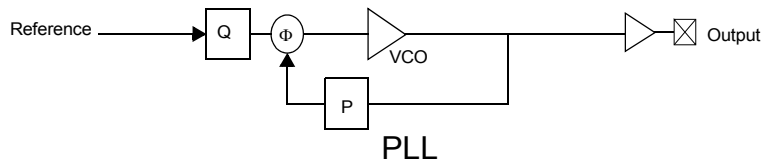
Figure 5. PLL Block Diagram

Absolute Maximum Conditions

The following table reflects stress ratings only, and functional operation at the maximums are not guaranteed.

Parameter	Description	Min	Max	Unit
$V_{DD, ABS}$	Maximum voltage on V_{DD} , or V_{DDX} with respect to ground	-0.5	4.0	V
$V_{I, ABS}$	Maximum voltage on any pin with respect to ground	-0.5	$V_{DD} + 0.5$	V

Crystal Requirements

Requirements to use parallel mode fundamental xtal. External capacitors are required in the crystal oscillator circuit. Please refer to the application note entitled **Crystal Oscillator Topics** for details.

Parameter	Description	Min	Max	Unit
X_F	Crystal fundamental frequency	10	31.25	MHz

Electrical Characteristics

DC Electrical Specifications

Parameter	Description	Min	Max	Unit
V_{DD}	Supply voltage	3.00	3.60	V
T_A	Ambient operating temperature	0	70	°C
V_{IL}	Input signal low voltage at pin S	-	0.35	V_{DD}
V_{IH}	Input signal high voltage at pin S	0.65	-	V_{DD}
R_{PUP}	Internal pull up resistance	10	100	k Ω
t_{PU}	Power up time for all V_{DDs} to reach minimum specified voltage (power ramps must be monotonic)	0.05	500	ms

3.3 V DC Device Characteristics

(Driving load, [Figure 6](#))

Parameter	Description	Min	Typ	Max	Unit
V_{OH}	Output high voltage, referenced to V_{DD}	-1.02	-0.95	-0.88	V
V_{OL}	Output low voltage, referenced to V_{DD}	-1.81	-1.70	-1.62	V

(Driving load, [Figure 7](#))

Parameter	Description	Min	Typ	Max	Unit
V_{OH}	Output high voltage	1.1	1.2	1.3	V
V_{OL}	Output low voltage	0	0	0	V

AC Electrical Specifications

Parameter	Description	Min	Max	Unit
f_{IN}	Input frequency with driven reference	1	133	MHz
$f_{XTAL,IN}$	Input frequency with crystal input	10	31.25	MHz
$C_{IN,CMOS}$	Input capacitance at S pin ^[1]	–	10	pF

AC Device Characteristics

Parameter	Description	Min	Max	Unit
t_{CYCLE}	Clock cycle time	2.50 (400 MHz)	8.00 (125 MHz)	ns
t_{JCRMS}	Cycle-to-cycle RMS jitter	–	0.25%	% t_{CYCLE}
	At 125 MHz frequency	–	20	ps
	At 400 MHz frequency	–	6.25	ps
t_{JCPK}	Cycle-to-cycle jitter (pk-pk)	–	1.75%	% t_{CYCLE}
	At 125 MHz frequency	–	140	ps
	At 200 MHz frequency, XF = 25 MHz	–	55	ps
	At 400 MHz frequency	–	43.75	ps
t_{JPRMS}	Period jitter RMS	–	0.25%	% t_{CYCLE}
	At 125 MHz frequency	–	20	ps
	At 400 MHz frequency	–	6.25	ps
t_{JPPK}	Period jitter (pk-pk)	–	2.0%	% t_{CYCLE}
	At 125 MHz frequency	–	160	ps
	At 200 MHz frequency, XF = 25 MHz	–	65	ps
	At 400 MHz frequency	–	50	ps
t_{JLT}	Long term RMS Jitter (P < 20)	–	1.75%	% t_{CYCLE}
	At 125 MHz frequency	–	140	ps
	At 400 MHz frequency	–	43.75	ps
t_{JLT}	Long term RMS Jitter (20 ≤ P < 40)	–	2.5%	% t_{CYCLE}
	At 125 MHz frequency	–	200	ps
	At 400 MHz frequency	–	62.5	ps
t_{JLT}	Long term RMS Jitter (40 ≤ P < 60)	–	3.5%	% t_{CYCLE}
	At 125 MHz frequency	–	280	ps
	At 400 MHz frequency	–	87.5	ps
Phase Noise	Phase Noise at 10 kHz (x8 mode) at 125 MHz	–107	–92	dBc
DC	Long term average output duty cycle	45	55	%
$t_{DC,ERR}$	Cycle-cycle duty cycle error at x8 with 15.625 MHz input	–	70	ps
t_{CR}, t_{CF}	Output rise and fall times (measured at 20% – 80% of V_{OHmin} and V_{OLmax})	100	400	ps
BW_{LOOP}	PLL Loop Bandwidth	50 kHz (–3 dB)	8 MHz (–20 dB)	

Note

1. Capacitance measured at frequency = 1 MHz, DC Bias = 0.9V, and VAC < 100 mV

State Transition Characteristics

Specifies the maximum settling time of the CLK and CLKB outputs from device power up. For V_{DD} and V_{DDX} any sequences are allowed to power up and power down the CY2213.

From	To	Transition Latency	Description
V_{DD}/V_{DDX} On	CLK/CLKB Normal	3 ms	Time from V_{DD}/V_{DDX} is applied and settled to CLK/CLKB outputs settled.

Functional Specifications

Crystal Input

The CY2213 receives its reference from an external crystal. Pin XIN is the reference crystal input, and pin XOUT is the reference crystal feedback. The parameters for the crystal are illustrated in [AC Device Characteristics on page 7](#). The oscillator circuit requires external capacitors. Please refer to the application note entitled **Crystal Oscillator Topics** for details.

Select Input

There is only one select input, pin S. This pin selects the frequency multiplier in the PLL, and is a standard LVCMOS input. The S pin has an internal pull up resistor. The multiplier selection is illustrated in [Frequency Table on page 3](#).

PECL Clock Output Driver

[Figure 6](#) and [Figure 7](#) show the Clock Output Driver.

Figure 6. Output Driving Load (-1)

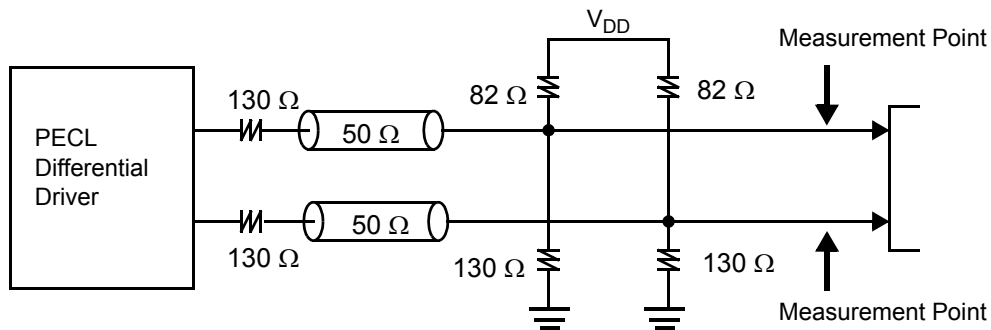
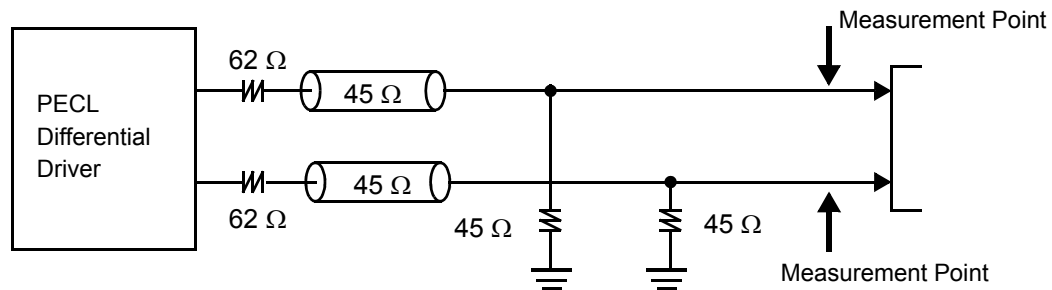
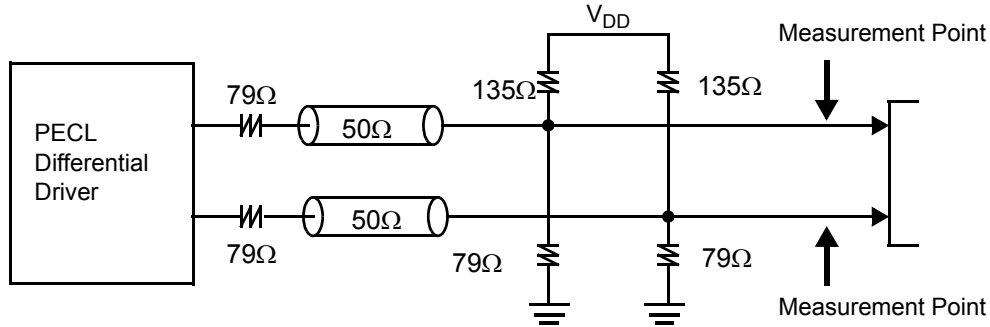

Figure 7. Output Driving Load (-2)



An alternative termination scheme can be used to drive a standard PECL fanout buffer.

Figure 8. Output Driving Load (-3)



The PECL differential driver is designed for low voltage, high frequency operation. It significantly reduces the transient switching noise and power dissipation when compared to conventional CMOS drivers. The nominal value of the channel impedance is 50Ω. The pull up and pull down resistors provide matching channel termination. The combination of the differential driver and the output network determines the voltage swing on the channel. The output clock is specified at the measurement point indicated in Figure 6 on page 8 and Figure 7 on page 8.

Signal Waveforms

A physical signal that appears at the pins of the device is deemed valid or invalid depending on its voltage and timing relations with other signals. This section defines the voltage and timing waveforms for the input and output pins of the CY2213. The Device Characteristics tables list the specifications for the device parameters that are defined here.

Input and Output voltage waveforms are defined as shown in Figure 9. Rise and fall times are defined as the 20% and 80% measurement points of $V_{OHmin} - V_{OLmax}$.

The device parameters are defined in Table 3. Figure 10 on page 10 shows the definition of long term duty cycle, which is simply the CLK waveform high time divided by the cycle time (defined at the crossing point). Long term duty cycle is the average over many (>10,000) cycles. DC is defined as the Output Clock Long Term Duty Cycle.

Table 3. Definition of Device Parameters

Parameter	Definition
V_{OH}, V_{OL}	Clock output high and low voltages
V_{IH}, V_{IL}	V_{DD} LVCMOS input high and low voltages
t_{CR}, t_{CF}	Clock output rise and fall times

Figure 9. Voltage Waveforms



Figure 10. Duty Cycle Jitter

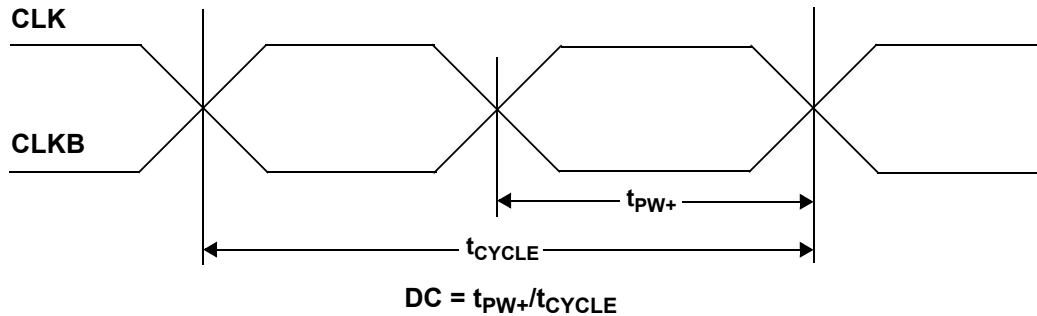

Jitter

This section defines the specifications that relate to timing uncertainty (or jitter) of the input and output waveforms. Figure 11 shows the definition of period jitter with respect to the falling edge of the CLK signal. Period jitter is the difference between the minimum and maximum cycle times over many cycles (typically 12,800 cycles at 400 MHz). Equal requirements apply for rising edges of the CLK signal. t_{JP} is defined as the output period jitter.

Figure 12 shows the definition of cycle-to-cycle jitter with respect to the falling edge of the CLK signal. Cycle-to-cycle jitter is the difference between cycle times of adjacent cycles over many cycles (typically 12,800 cycles at 400 MHz). Equal requirements

apply for rising edges of the CLK signal. t_{JC} is defined as the Clock Output Cycle-to-cycle Jitter.

Figure 13 on page 11 shows the definition of cycle-to-cycle duty cycle error. Cycle-to-cycle duty cycle error is defined as the difference between high-times of adjacent cycles over many cycles (typically 12,800 cycles at 400 MHz). Equal requirements apply to the low-times. $t_{DC,ERR}$ is defined as the Clock Output Cycle-to-cycle Duty Cycle Error.

Figure 14 on page 11 shows the definition of long-term jitter error. Long term jitter is defined as the accumulated timing error over many cycles (typically 12,800 cycles at 400 MHz). It applies to both rising and falling edges. t_{JLT} is defined as the long term jitter.

Figure 11. Period Jitter

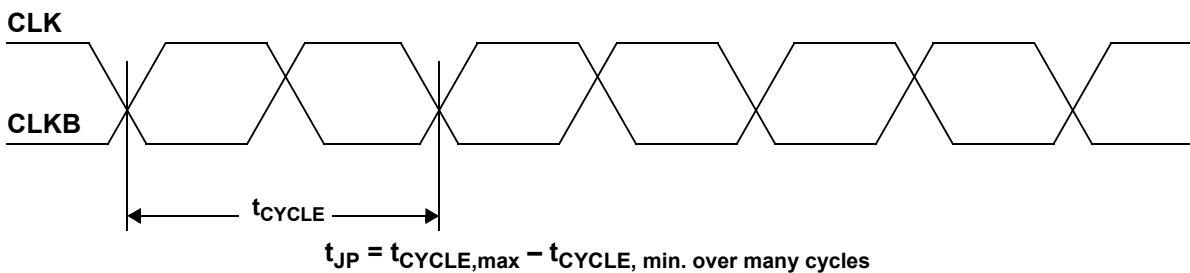

Figure 12. Cycle-to-cycle Jitter

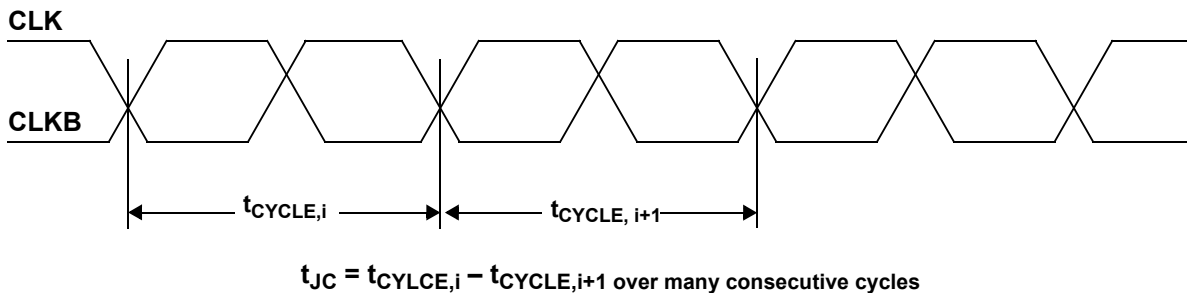

Figure 13. Cycle-to-cycle Duty Cycle Error

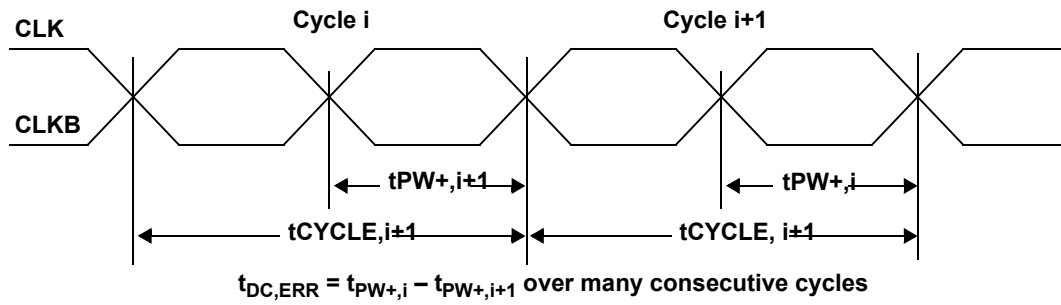
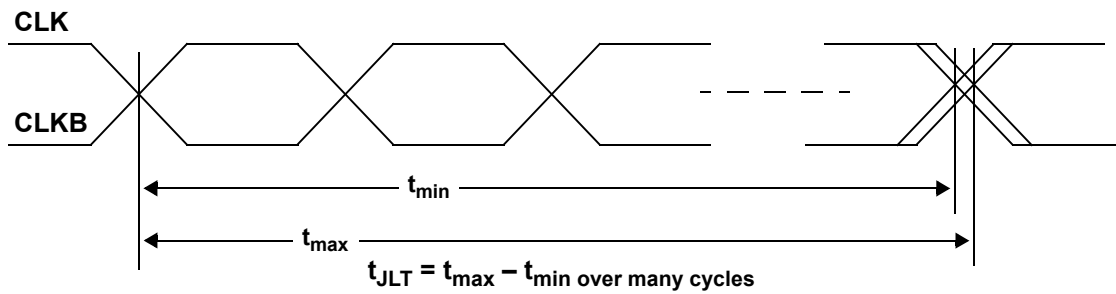

Figure 14. Long-term Jitter



Ordering Information

Ordering Code	Package Type	Operating Range	Operating Voltage
CY2213ZXC-1	16-pin TSSOP	Commercial, to 400 MHz	3.3 V
CY2213ZXC-1T	16-pin TSSOP – Tape and Reel	Commercial, to 400 MHz	3.3 V

Ordering Code Definitions

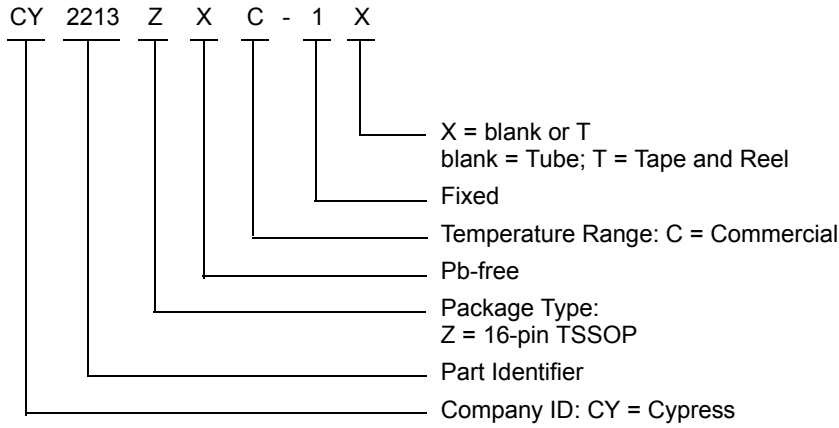

Package Diagrams

Figure 15. 16-pin TSSOP (4.40 mm Body) Z16.173/ZZ16.173 Package Outline, 51-85091

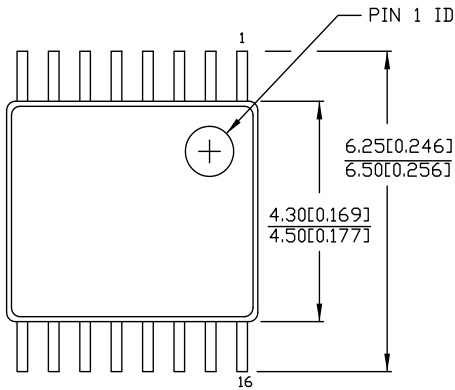

DIMENSIONS IN MM[INCHES] MIN. MAX.

REFERENCE JEDEC MO-153

PACKAGE WEIGHT 0.05gms

PART #	
Z16.173	STANDARD PKG.
ZZ16.173	LEAD FREE PKG.

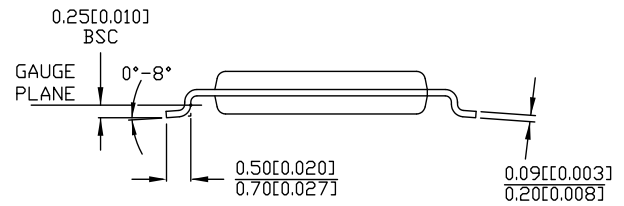
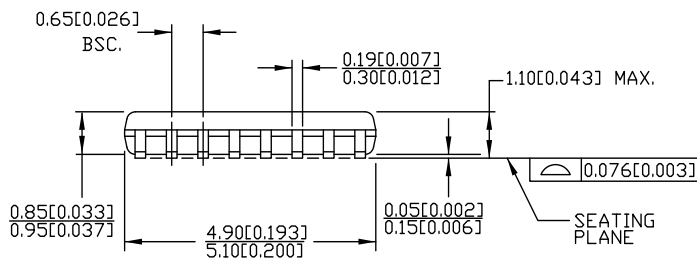

51-85091 *E

Acronyms

Acronym	Description
CMOS	complementary metal-oxide semiconductor
DC	duty cycle
EMI	electromagnetic interference
LVC MOS	low voltage complementary metal-oxide semiconductor
LVPECL	low voltage pseudo (positive) emitter coupled logic
OE	output enable
PECL	pseudo (positive) emitter coupled logic
PLL	phase locked loop
TSSOP	thin-shrink small outline package

Document Conventions

Units of Measure

Symbol	Unit of Measure
°C	degree Celsius
kΩ	kilohm
MHz	megahertz
ms	millisecond
ns	nanosecond
Ω	ohm
%	percent
pF	picofarad
ps	picosecond
V	volt

Document History Page

Document Title: CY2213, High Frequency Programmable PECL Clock Generator				
Document Number: 38-07263				
Rev.	ECN	Submission Date	Orig. of Change	Description of Change
**	113090	02/06/02	DSG	Change from Spec number: 38-01100 to 38-07263
*A	113512	05/24/02	CKN	Added PLL Block Diagram (Figure 5) and PLL frequency equation
*B	121882	12/14/02	RBI	Power up requirements added to Operating Conditions
*C	123215	12/19/02	LJN	Previous revision was released with incorrect *A numbering in footer; *A should have been *B (and was changed accordingly)
*D	124012	03/05/03	CKN	Added -2 to data sheet; edited line 3 of Benefits
*E	126557	05/27/03	RGL	Added 200 MHz Jitter Spec. Added optional output termination
*F	2738056	07/14/09	CXQ	Obsolete document.
*G	2742301	07/22/09	CXQ	Undo obsolete document. Removed all references to obsolete -2 option. Changed Ordering Information entry to Pb-free CY2213ZXC-1 and -1T. Revised the version of Package Drawing from 51-85091 ** to 51-85091 *A.
*H	3709157	08/10/2012	PURU	Added Ordering Code Definitions . Updated Package Diagrams (spec 51-85091 (Changed revision from *A to *D)). Added Acronyms and Units of Measure . Updated in new template.
*I	4575273	11/20/2014	PURU	Added related documentation hyperlink in page 1. Updated Package Diagrams.
*J	4888407	08/18/2015	XHT	Sunset review, no change
*K	5992889	12/13/2017	AESATMP8	Updated logo and Copyright.

Sales, Solutions, and Legal Information

Worldwide Sales and Design Support

Cypress maintains a worldwide network of offices, solution centers, manufacturer's representatives, and distributors. To find the office closest to you, visit us at [Cypress Locations](#).

Products

ARM [®] Cortex [®] Microcontrollers	cypress.com/arm
Automotive	cypress.com/automotive
Clocks & Buffers	cypress.com/clocks
Interface	cypress.com/interface
Internet of Things	cypress.com/iot
Memory	cypress.com/memory
Microcontrollers	cypress.com/mcu
PSoC	cypress.com/psoc
Power Management ICs	cypress.com/pmic
Touch Sensing	cypress.com/touch
USB Controllers	cypress.com/usb
Wireless Connectivity	cypress.com/wireless

PSoC[®] Solutions

[PSoC 1](#) | [PSoC 3](#) | [PSoC 4](#) | [PSoC 5LP](#) | [PSoC 6](#)

Cypress Developer Community

[Forums](#) | [WICED IOT Forums](#) | [Projects](#) | [Video](#) | [Blogs](#) | [Training](#) | [Components](#)

Technical Support

cypress.com/support

© Cypress Semiconductor Corporation, 2002-2017. This document is the property of Cypress Semiconductor Corporation and its subsidiaries, including Spansion LLC ("Cypress"). This document, including any software or firmware included or referenced in this document ("Software"), is owned by Cypress under the intellectual property laws and treaties of the United States and other countries worldwide. Cypress reserves all rights under such laws and treaties and does not, except as specifically stated in this paragraph, grant any license under its patents, copyrights, trademarks, or other intellectual property rights. If the Software is not accompanied by a license agreement and you do not otherwise have a written agreement with Cypress governing the use of the Software, then Cypress hereby grants you a personal, non-exclusive, nontransferable license (without the right to sublicense) (1) under its copyright rights in the Software (a) for Software provided in source code form, to modify and reproduce the Software solely for use with Cypress hardware products, only internally within your organization, and (b) to distribute the Software in binary code form externally to end users (either directly or indirectly through resellers and distributors), solely for use on Cypress hardware product units, and (2) under those claims of Cypress's patents that are infringed by the Software (as provided by Cypress, unmodified) to make, use, distribute, and import the Software solely for use with Cypress hardware products. Any other use, reproduction, modification, translation, or compilation of the Software is prohibited.

TO THE EXTENT PERMITTED BY APPLICABLE LAW, CYPRESS MAKES NO WARRANTY OF ANY KIND, EXPRESS OR IMPLIED, WITH REGARD TO THIS DOCUMENT OR ANY SOFTWARE OR ACCOMPANYING HARDWARE, INCLUDING, BUT NOT LIMITED TO, THE IMPLIED WARRANTIES OF MERCHANTABILITY AND FITNESS FOR A PARTICULAR PURPOSE. To the extent permitted by applicable law, Cypress reserves the right to make changes to this document without further notice. Cypress does not assume any liability arising out of the application or use of any product or circuit described in this document. Any information provided in this document, including any sample design information or programming code, is provided only for reference purposes. It is the responsibility of the user of this document to properly design, program, and test the functionality and safety of any application made of this information and any resulting product. Cypress products are not designed, intended, or authorized for use as critical components in systems designed or intended for the operation of weapons, weapons systems, nuclear installations, life-support devices or systems, other medical devices or systems (including resuscitation equipment and surgical implants), pollution control or hazardous substances management, or other uses where the failure of the device or system could cause personal injury, death, or property damage ("Unintended Uses"). A critical component is any component of a device or system whose failure to perform can be reasonably expected to cause the failure of the device or system, or to affect its safety or effectiveness. Cypress is not liable, in whole or in part, and you shall and hereby do release Cypress from any claim, damage, or other liability arising from or related to all Unintended Uses of Cypress products. You shall indemnify and hold Cypress harmless from and against all claims, costs, damages, and other liabilities, including claims for personal injury or death, arising from or related to any Unintended Uses of Cypress products.

Cypress, the Cypress logo, Spansion, the Spansion logo, and combinations thereof, WICED, PSoC, CapSense, EZ-USB, F-RAM, and Traveo are trademarks or registered trademarks of Cypress in the United States and other countries. For a more complete list of Cypress trademarks, visit cypress.com. Other names and brands may be claimed as property of their respective owners.



Компания «ЭлектроПласт» предлагает заключение долгосрочных отношений при поставках импортных электронных компонентов на взаимовыгодных условиях!

Наши преимущества:

- Оперативные поставки широкого спектра электронных компонентов отечественного и импортного производства напрямую от производителей и с крупнейших мировых складов;
- Поставка более 17-ти миллионов наименований электронных компонентов;
- Поставка сложных, дефицитных, либо снятых с производства позиций;
- Оперативные сроки поставки под заказ (от 5 рабочих дней);
- Экспресс доставка в любую точку России;
- Техническая поддержка проекта, помощь в подборе аналогов, поставка прототипов;
- Система менеджмента качества сертифицирована по Международному стандарту ISO 9001;
- Лицензия ФСБ на осуществление работ с использованием сведений, составляющих государственную тайну;
- Поставка специализированных компонентов (Xilinx, Altera, Analog Devices, Intersil, Interpoint, Microsemi, Aeroflex, Peregrine, Syfer, Eurofarad, Texas Instrument, Miteq, Cobham, E2V, MA-COM, Hittite, Mini-Circuits, General Dynamics и др.);

Помимо этого, одним из направлений компании «ЭлектроПласт» является направление «Источники питания». Мы предлагаем Вам помощь Конструкторского отдела:

- Подбор оптимального решения, техническое обоснование при выборе компонента;
- Подбор аналогов;
- Консультации по применению компонента;
- Поставка образцов и прототипов;
- Техническая поддержка проекта;
- Защита от снятия компонента с производства.



Как с нами связаться

Телефон: 8 (812) 309 58 32 (многоканальный)

Факс: 8 (812) 320-02-42

Электронная почта: org@eplast1.ru

Адрес: 198099, г. Санкт-Петербург, ул. Калинина, дом 2, корпус 4, литера А.