



**Please note that Cypress is an Infineon Technologies Company.**

The document following this cover page is marked as “Cypress” document as this is the company that originally developed the product. Please note that Infineon will continue to offer the product to new and existing customers as part of the Infineon product portfolio.

**Continuity of document content**

The fact that Infineon offers the following product as part of the Infineon product portfolio does not lead to any changes to this document. Future revisions will occur when appropriate, and any changes will be set out on the document history page.

**Continuity of ordering part numbers**

Infineon continues to support existing part numbers. Please continue to use the ordering part numbers listed in the datasheet for ordering.

## Features

- High Speed: 45 ns
- Wide voltage range: 2.2 V to 3.6 V and 4.5 V to 5.5 V
- Ultra Low Standby Power
  - Typical standby current: 2 μA
  - Maximum standby current: 8 μA
- Ultra Low Active Power
  - Typical active current: 1.8 mA at f = 1 MHz
- Easy Memory Expansion with  $\overline{CE}_1$ ,  $CE_2$ , and  $\overline{OE}$  Features
- Automatic Power Down when Deselected
- CMOS for Optimum Speed and Power
- Available in Pb-free 48-ball very fine-pitch ball grid array (VFBGA) packages

## Functional Description

The CY62156ESL is a high performance CMOS static RAM organized as 512K words by 16 bits. This device features advanced circuit design to provide ultra low active current. This is ideal for providing More Battery Life™ (MoBL®) in portable

applications such as cellular telephones. The device also has an automatic power down feature that significantly reduces power consumption when addresses are not toggling. Place the device in standby mode when deselected ( $\overline{CE}_1$  HIGH or  $CE_2$  LOW). The input or output pins ( $I/O_0$  through  $I/O_{15}$ ) are placed in a high impedance state when the device is deselected ( $\overline{CE}_1$  HIGH or  $CE_2$  LOW), the outputs are disabled ( $\overline{OE}$  HIGH), Byte High Enable and Byte Low Enable are disabled ( $\overline{BHE}$ ,  $\overline{BLE}$  HIGH), or a write operation is active ( $\overline{CE}_1$  LOW,  $CE_2$  HIGH and  $\overline{WE}$  LOW).

To write to the device, take Chip Enable ( $\overline{CE}_1$  LOW and  $CE_2$  HIGH) and Write Enable ( $\overline{WE}$ ) inputs LOW. If Byte Low Enable ( $\overline{BLE}$ ) is LOW, then data from  $I/O$  pins ( $I/O_0$  through  $I/O_7$ ) is written into the location specified on the address pins ( $A_0$  through  $A_{18}$ ). If Byte High Enable ( $\overline{BHE}$ ) is LOW, then data from  $I/O$  pins ( $I/O_8$  through  $I/O_{15}$ ) is written into the location specified on the address pins ( $A_0$  through  $A_{18}$ ).

To read from the device, take Chip Enable ( $\overline{CE}_1$  LOW and  $CE_2$  HIGH) and Output Enable ( $\overline{OE}$ ) LOW while forcing the Write Enable ( $\overline{WE}$ ) HIGH. If Byte Low Enable ( $\overline{BLE}$ ) is LOW, then data from the memory location specified by the address pins appear on  $I/O_0$  to  $I/O_7$ . If Byte High Enable ( $\overline{BHE}$ ) is LOW, then data from memory appears on  $I/O_8$  to  $I/O_{15}$ . See the [Truth Table on page 11](#) for a complete description of read and write modes.

For a complete list of related documentation, [click here](#).

## Logic Block Diagram

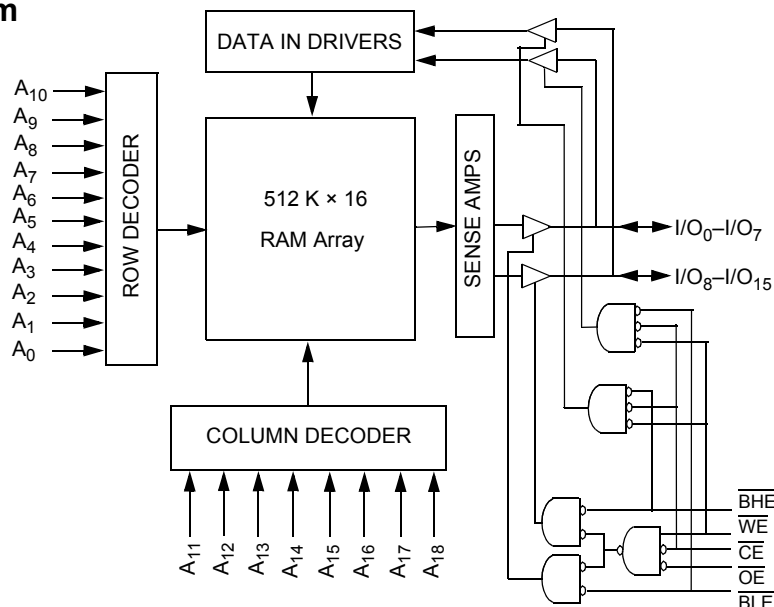

## Contents

<b>Pin Configurations</b> .....	<b>3</b>	<b>Ordering Information</b> .....	<b>12</b>
<b>Product Portfolio</b> .....	<b>3</b>	Ordering Code Definitions .....	12
<b>Maximum Ratings</b> .....	<b>4</b>	<b>Package Diagrams</b> .....	<b>13</b>
<b>Operating Range</b> .....	<b>4</b>	<b>Acronyms</b> .....	<b>14</b>
<b>Electrical Characteristics</b> .....	<b>4</b>	<b>Document Conventions</b> .....	<b>14</b>
<b>Capacitance</b> .....	<b>5</b>	Units of Measure .....	14
<b>Thermal Resistance</b> .....	<b>5</b>	<b>Document History Page</b> .....	<b>15</b>
<b>AC Test Loads and Waveforms</b> .....	<b>5</b>	<b>Sales, Solutions, and Legal Information</b> .....	<b>16</b>
<b>Data Retention Characteristics</b> .....	<b>6</b>	Worldwide Sales and Design Support .....	16
<b>Data Retention Waveform</b> .....	<b>6</b>	Products .....	16
<b>Switching Characteristics</b> .....	<b>7</b>	PSoC <sup>®</sup> Solutions .....	16
<b>Switching Waveforms</b> .....	<b>8</b>	Cypress Developer Community .....	16
<b>Truth Table</b> .....	<b>11</b>	Technical Support .....	16

## Pin Configurations

Figure 1. 48-ball VFBGA pinout (Top View) [1]

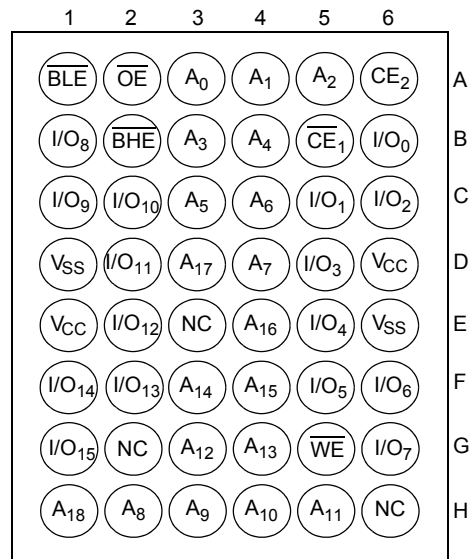

## Product Portfolio

Product	Range	V <sub>CC</sub> Range (V) [2]	Speed (ns)	Power Dissipation					
				Operating I <sub>CC</sub> , (mA)				Standby, I <sub>SB2</sub> (μA)	
				f = 1MHz		f = f <sub>max</sub>			
				Typ [3]	Max	Typ [3]	Max	Typ [3]	Max
CY62156ESL	Industrial	2.2 V to 3.6 V and 4.5 V to 5.5 V	45	1.8	3	18	25	2	8

### Notes

1. NC pins are not connected on the die.
2. Datasheet specifications are not guaranteed for V<sub>CC</sub> in the range of 3.6 V to 4.5 V.
3. Typical values are included for reference only and are not guaranteed or tested. Typical values are measured at V<sub>CC</sub> = V<sub>CC(typ)</sub>, T<sub>A</sub> = 25 °C.

## Maximum Ratings

Exceeding the maximum ratings may impair the useful life of the device. User guidelines are not tested.

Storage Temperature .....	-65 °C to + 150 °C
Ambient Temperature with Power Applied .....	-55 °C to + 125 °C
Supply Voltage to Ground Potential .....	-0.5 V to 6.0 V
DC Voltage Applied to Outputs in High Z State <sup>[4, 5]</sup> .....	-0.5 V to 6.0 V
DC Input Voltage <sup>[4, 5]</sup> .....	-0.5 V to 6.0 V

Output Current into Outputs (LOW) .....	20 mA
Static Discharge Voltage (MIL-STD-883, Method 3015) .....	> 2,001V
Latch Up Current .....	> 200 mA

## Operating Range

Device	Range	Ambient Temperature	V <sub>CC</sub> <sup>[6]</sup>
CY62156ESL	Industrial	-40 °C to +85 °C	2.2 V to 3.6 V, and 4.5 V to 5.5 V

## Electrical Characteristics

Over the Operating Range

Parameter	Description	Test Conditions	45 ns			Unit	
			Min	Typ <sup>[1]</sup>	Max		
V <sub>OH</sub>	Output HIGH Voltage	2.2 ≤ V <sub>CC</sub> ≤ 2.7	I <sub>OH</sub> = -0.1 mA	2.0	-	-	V
		2.7 ≤ V <sub>CC</sub> ≤ 3.6	I <sub>OH</sub> = -1.0 mA	2.4	-	-	
		4.5 ≤ V <sub>CC</sub> ≤ 5.5	I <sub>OH</sub> = -1.0 mA	2.4	-	-	
V <sub>OL</sub>	Output LOW Voltage	2.2 ≤ V <sub>CC</sub> ≤ 2.7	I <sub>OL</sub> = 0.1 mA	-	-	0.4	V
		2.7 ≤ V <sub>CC</sub> ≤ 3.6	I <sub>OL</sub> = 2.1mA	-	-	0.4	
		4.5 ≤ V <sub>CC</sub> ≤ 5.5	I <sub>OL</sub> = 2.1mA	-	-	0.4	
V <sub>IH</sub>	Input HIGH Voltage	2.2 ≤ V <sub>CC</sub> ≤ 2.7		1.8	-	V <sub>CC</sub> + 0.3	V
		2.7 ≤ V <sub>CC</sub> ≤ 3.6		2.2	-	V <sub>CC</sub> + 0.3	
		4.5 ≤ V <sub>CC</sub> ≤ 5.5		2.2	-	V <sub>CC</sub> + 0.5	
V <sub>IL</sub>	Input LOW Voltage	2.2 ≤ V <sub>CC</sub> ≤ 2.7		-0.3	-	0.6	V
		2.7 ≤ V <sub>CC</sub> ≤ 3.6		-0.3	-	0.8	
		4.5 ≤ V <sub>CC</sub> ≤ 5.5		-0.5	-	0.8	
I <sub>IX</sub>	Input Leakage Current	GND ≤ V <sub>I</sub> ≤ V <sub>CC</sub>		-1	-	+1	μA
I <sub>OZ</sub>	Output Leakage Current	GND ≤ V <sub>O</sub> ≤ V <sub>CC</sub> , Output Disabled		-1	-	+1	μA
I <sub>CC</sub>	V <sub>CC</sub> Operating Supply Current	f = f <sub>max</sub> = 1/t <sub>RC</sub>	V <sub>CC</sub> = V <sub>CCmax</sub> ,	-	18	25	mA
		f = 1 MHz	I <sub>OUT</sub> = 0 mA, CMOS levels	-	1.8	3	
I <sub>SB1</sub>	Automatic CE Power down Current – CMOS Inputs	$\overline{CE}_1 \geq V_{CC} - 0.2 V$ , $CE_2 \leq 0.2 V$ , $V_{IN} \geq V_{CC} - 0.2 V$ or $V_{IN} \leq 0.2 V$ , f = f <sub>max</sub> (Address and Data Only), f = 0 ( $\overline{OE}$ , $\overline{BHE}$ , $\overline{BLE}$ and $\overline{WE}$ ), V <sub>CC</sub> = V <sub>CC(max)</sub>		-	2	8	μA
I <sub>SB2</sub> <sup>[7]</sup>	Automatic CE Power down Current – CMOS Inputs	$\overline{CE}_1 \geq V_{CC} - 0.2 V$ or $CE_2 \leq 0.2 V$ , $V_{IN} \geq V_{CC} - 0.2 V$ or $V_{IN} \leq 0.2 V$ , f = 0, V <sub>CC</sub> = V <sub>CC(max)</sub>		-	2	8	μA

### Notes

- V<sub>IL</sub>(min) = -2.0 V for pulse durations less than 20 ns.
- V<sub>IH</sub>(max) = V<sub>CC</sub> + 0.75 V for pulse durations less than 20 ns.
- Full Device AC operation assumes a 100 μs ramp time from 0 to V<sub>CC</sub>(min) and 200 μs wait time after V<sub>CC</sub> stabilization.
- Only chip enables (CE<sub>1</sub> and CE<sub>2</sub>) need to be tied to CMOS levels to meet the I<sub>SB2</sub> / I<sub>CCDR</sub> spec. Other inputs can be left floating.

### Capacitance

Parameter <sup>[8]</sup>	Description	Test Conditions	Max	Unit
C <sub>IN</sub>	Input capacitance	T <sub>A</sub> = 25 °C, f = 1 MHz, V <sub>CC</sub> = V <sub>CC(typ)</sub>	10	pF
C <sub>OUT</sub>	Output capacitance		10	pF

### Thermal Resistance

Parameter <sup>[8]</sup>	Description	Test Conditions	48-ball BGA	Unit
Θ <sub>JA</sub>	Thermal resistance (junction to ambient)	Still Air, soldered on a 3 × 4.5 inch, two-layer printed circuit board	72	°C/W
Θ <sub>JC</sub>	Thermal resistance (junction to case)		8.86	°C/W

### AC Test Loads and Waveforms

Figure 2. AC Test Loads and Waveforms

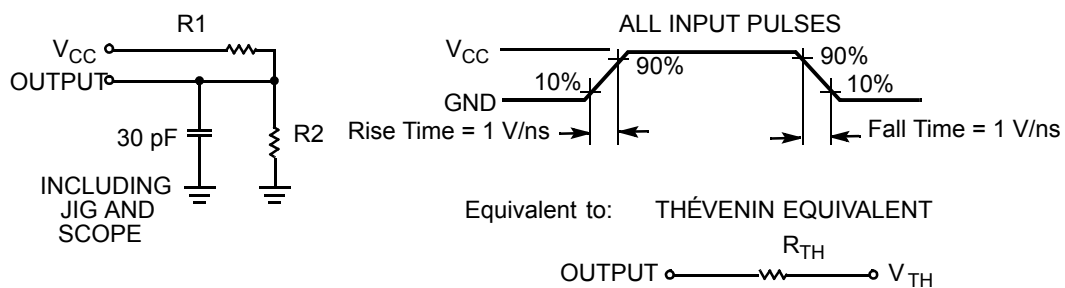

Parameters	2.5 V	3.0 V	5.0 V	Unit
R1	16667	1103	1800	Ω
R2	15385	1554	990	Ω
R <sub>TH</sub>	8000	645	639	Ω
V <sub>TH</sub>	1.20	1.75	1.77	V

**Note**

8. Tested initially and after any design or process changes that may affect these parameters.

## Data Retention Characteristics

Over the Operating Range

Parameter	Description	Conditions	Min	Typ <sup>[9]</sup>	Max	Unit
$V_{DR}$	$V_{CC}$ for Data Retention		1.5	–	–	V
$I_{CCDR}$ <sup>[10]</sup>	Data Retention Current	$CE_1 \geq V_{CC} - 0.2\text{ V}$ , $CE_2 \leq 0.2\text{ V}$ , $V_{IN} \geq V_{CC} - 0.2\text{ V}$ or $V_{IN} \leq 0.2\text{ V}$ , $V_{CC} = 1.5\text{ V}$	–	2	5	$\mu\text{A}$
$t_{CDR}$ <sup>[11]</sup>	Chip Deselect to Data Retention Time		0	–	–	ns
$t_R$ <sup>[12]</sup>	Operation Recovery Time		45	–	–	ns

## Data Retention Waveform

Figure 3. Data Retention Waveform

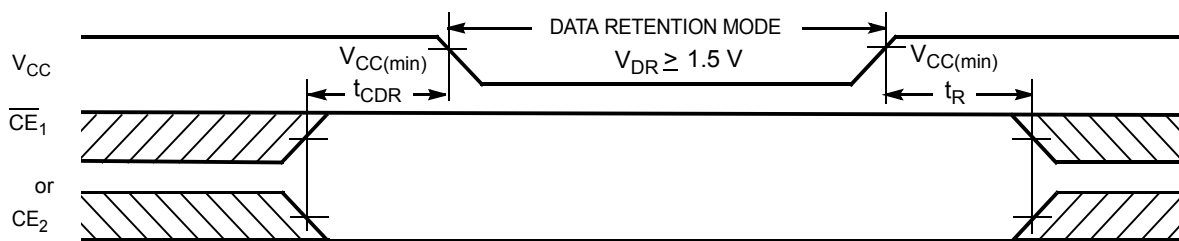

### Notes

9. Typical values are included for reference only and are not guaranteed or tested. Typical values are measured at  $V_{CC} = V_{CC(typ)}$ ,  $T_A = 25\text{ }^\circ\text{C}$ .
10. Only chip enables ( $\overline{CE}_1$  and  $CE_2$ ) need to be tied to CMOS levels to meet the  $I_{SB2} / I_{CCDR}$  spec. Other inputs can be left floating.
11. Tested initially and after any design or process changes that may affect these parameters.
12. Full device operation requires linear  $V_{CC}$  ramp from  $V_{DR}$  to  $V_{CC(min)} \geq 100\text{ }\mu\text{s}$  or stable at  $V_{CC(min)} \geq 100\text{ }\mu\text{s}$ .

## Switching Characteristics

Over the Operating Range

Parameter <sup>[13]</sup>	Description	45 ns		Unit
		Min	Max	
<b>Read Cycle</b>				
$t_{RC}$	Read Cycle Time	45	–	ns
$t_{AA}$	Address to Data Valid	–	45	ns
$t_{OHA}$	Data Hold from Address Change	10	–	ns
$t_{ACE}$	$\overline{CE}_1$ LOW and $CE_2$ HIGH to Data Valid	–	45	ns
$t_{DOE}$	$\overline{OE}$ LOW to Data Valid	–	22	ns
$t_{LZOE}$	$\overline{OE}$ LOW to Low Z <sup>[14]</sup>	5	–	ns
$t_{HZOE}$	$\overline{OE}$ HIGH to High Z <sup>[14, 15]</sup>	–	18	ns
$t_{LZCE}$	$\overline{CE}_1$ LOW and $CE_2$ HIGH to Low Z <sup>[14]</sup>	10	–	ns
$t_{HZCE}$	$\overline{CE}_1$ HIGH and $CE_2$ LOW to High Z <sup>[14, 15]</sup>	–	18	ns
$t_{PU}$	$\overline{CE}_1$ LOW and $CE_2$ HIGH to Power Up	0	–	ns
$t_{PD}$	$\overline{CE}_1$ HIGH and $CE_2$ LOW to Power Down	–	45	ns
$t_{DBE}$	$\overline{BLE}/\overline{BHE}$ LOW to Data Valid	–	22	ns
$t_{LZBE}$	$\overline{BLE}/\overline{BHE}$ LOW to Low Z <sup>[14]</sup>	5	–	ns
$t_{HZBE}$	$\overline{BLE}/\overline{BHE}$ HIGH to High Z <sup>[14, 15]</sup>	–	18	ns
<b>Write Cycle<sup>[16, 17]</sup></b>				
$t_{WC}$	Write Cycle Time	45	–	ns
$t_{SCE}$	$\overline{CE}_1$ LOW and $CE_2$ HIGH to Write End	35	–	ns
$t_{AW}$	Address Setup to Write End	35	–	ns
$t_{HA}$	Address Hold from Write End	0	–	ns
$t_{SA}$	Address Setup to Write Start	0	–	ns
$t_{PWE}$	$\overline{WE}$ Pulse Width	35	–	ns
$t_{BW}$	$\overline{BLE}/\overline{BHE}$ LOW to Write End	35	–	ns
$t_{SD}$	Data Setup to Write End	25	–	ns
$t_{HD}$	Data Hold from Write End	0	–	ns
$t_{HZWE}$	$\overline{WE}$ LOW to High Z <sup>[14, 15]</sup>	–	18	ns
$t_{LZWE}$	$\overline{WE}$ HIGH to Low Z <sup>[14]</sup>	10	–	ns

### Notes

13. Test conditions for all parameters other than tri-state parameters assume signal transition time of 3 ns or less, timing reference levels of  $V_{CC(typ)}/2$ , input pulse levels of 0 to  $V_{CC(typ)}$ , and output loading of the specified  $I_{OL}/I_{OH}$  as shown in the [Figure 2 on page 5](#).
14. At any temperature and voltage condition,  $t_{HZCE}$  is less than  $t_{LZCE}$ ,  $t_{HZBE}$  is less than  $t_{LZBE}$ ,  $t_{HZOE}$  is less than  $t_{LZOE}$ , and  $t_{HZWE}$  is less than  $t_{LZWE}$  for any device.
15.  $t_{HZOE}$ ,  $t_{HZCE}$ ,  $t_{HZBE}$ , and  $t_{HZWE}$  transitions are measured when the outputs enter a high-impedance state.
16. The internal write time of the memory is defined by the overlap of  $\overline{WE}$ ,  $CE_1 = V_{IL}$ ,  $BHE$ ,  $\overline{BLE}$  or both =  $V_{IL}$ , and  $CE_2 = V_{IH}$ . All signals must be active to initiate a write and any of these signals can terminate a write by going inactive. The data input setup and hold timing must be referenced to the edge of the signal that terminates the write.
17. The minimum write cycle pulse width for Write Cycle No. 3 ( $\overline{WE}$  controlled,  $\overline{OE}$  LOW) should be equal to the sum of  $t_{SD}$  and  $t_{HZWE}$ .



## Switching Waveforms

Figure 4. Read Cycle No. 1: Address Transition Controlled [18, 19]

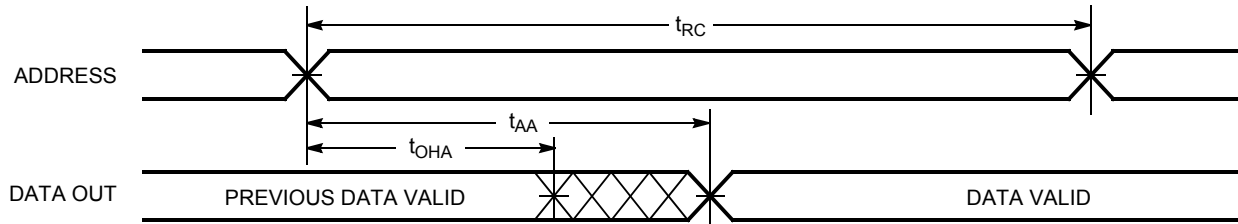
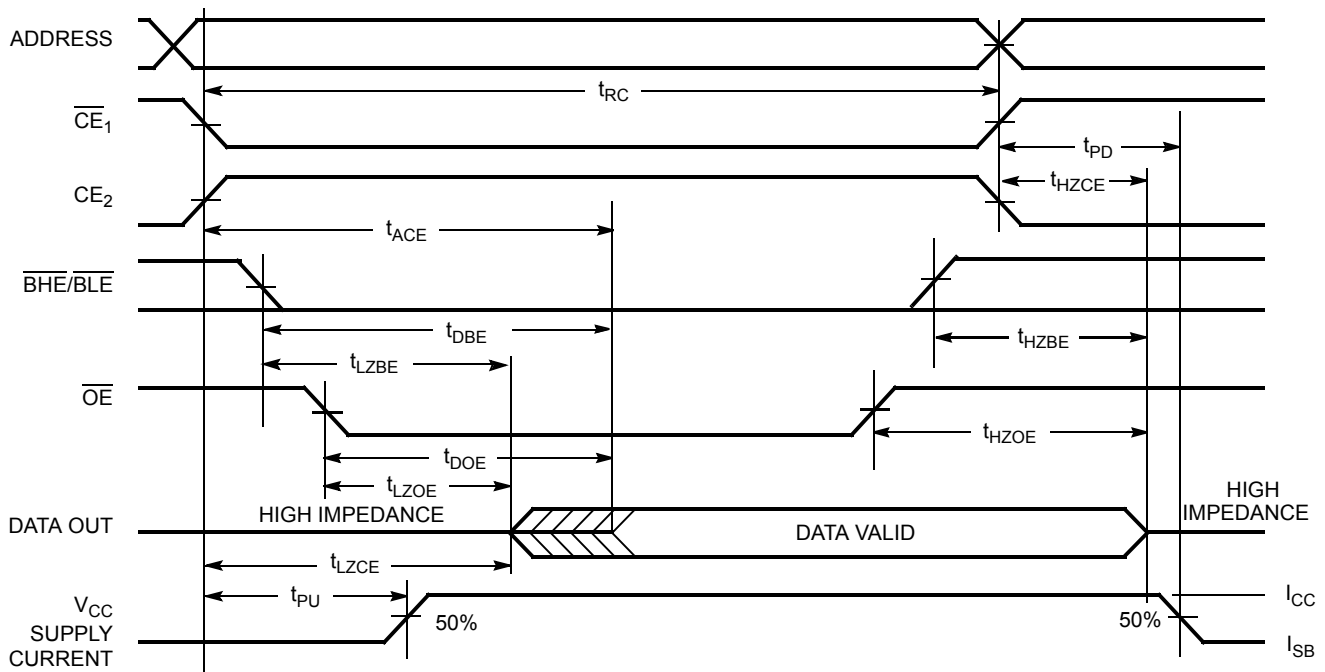

Figure 5. Read Cycle No. 2:  $\overline{OE}$  Controlled [19, 20]



### Notes

18. The device is continuously selected.  $\overline{OE}$ ,  $\overline{CE}_1 = V_{IL}$ ,  $\overline{BHE}$ ,  $\overline{BLE}$ , or both =  $V_{IL}$ , and  $CE_2 = V_{IH}$ .
19. WE is HIGH for read cycle.
20. Address valid before or similar to  $\overline{CE}_1$ ,  $\overline{BHE}$ ,  $\overline{BLE}$  transition LOW and  $CE_2$  transition HIGH.

Switching Waveforms (continued)

Figure 6. Write Cycle No 1:  $\overline{WE}$  Controlled [21, 22, 23]

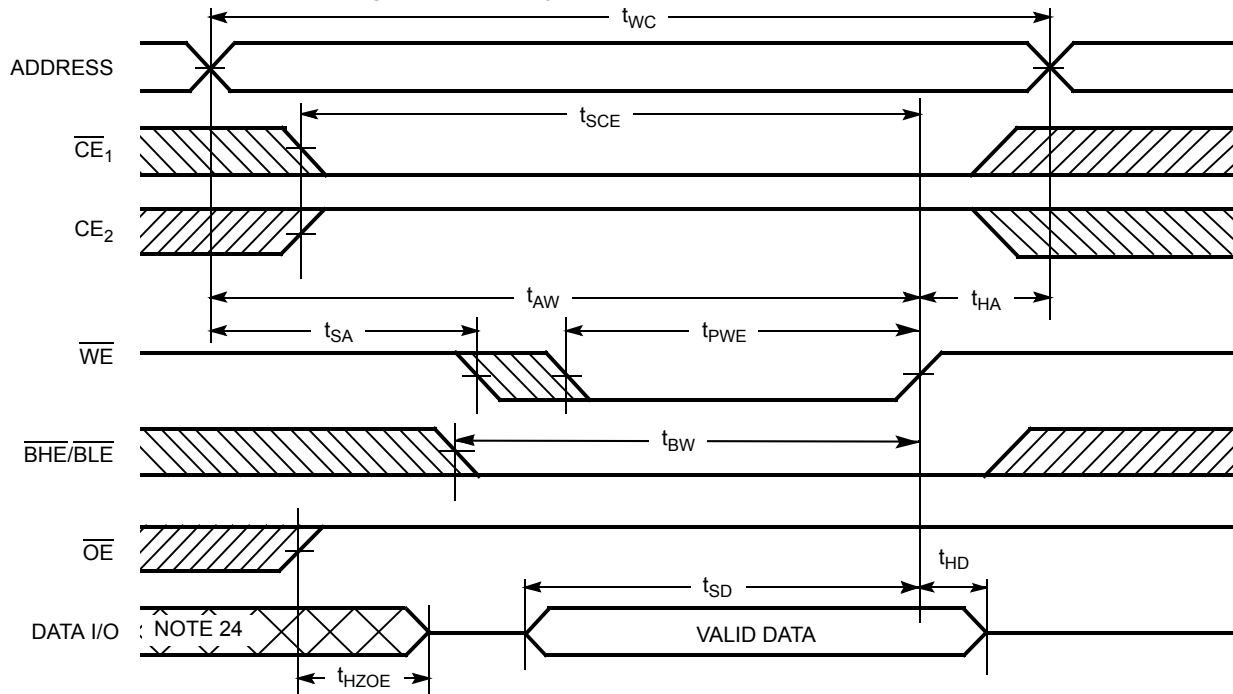
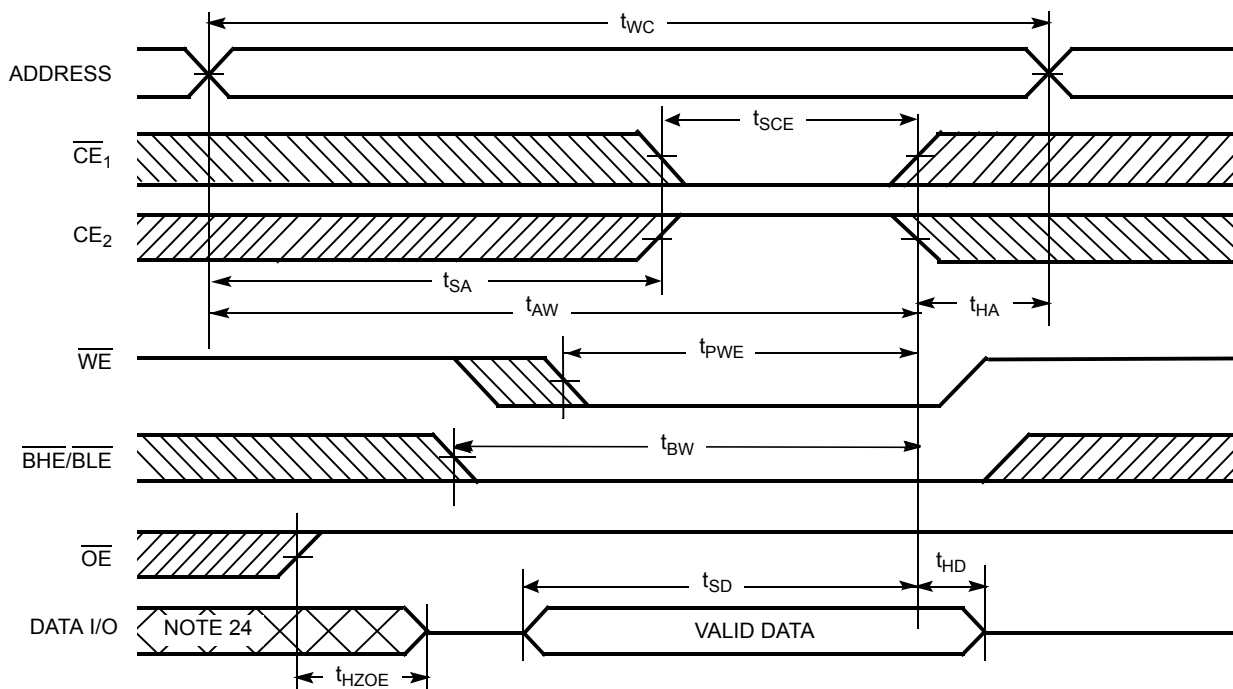

Figure 7. Write Cycle 2:  $\overline{CE}$  Controlled [21, 22, 23]



Notes

- 21. The internal write time of the memory is defined by the overlap of  $\overline{WE}$ ,  $\overline{CE}_1 = V_{IL}$ ,  $\overline{BHE}$ ,  $\overline{BLE}$  or both =  $V_{IL}$ , and  $CE_2 = V_{IH}$ . All signals must be active to initiate a write and any of these signals can terminate a write by going inactive. The data input setup and hold timing must be referenced to the edge of the signal that terminates the write.
- 22. Data I/O is high impedance if  $\overline{OE} = V_{IH}$ .
- 23. If  $\overline{CE}_1$  goes HIGH and  $CE_2$  goes LOW simultaneously with  $\overline{WE} = V_{IH}$ , the output remains in a high impedance state.
- 24. During this period, the I/Os are in output state. Do not apply input signals.

Switching Waveforms (continued)

Figure 8. Write Cycle 3:  $\overline{WE}$  controlled,  $\overline{OE}$  LOW [25, 27]

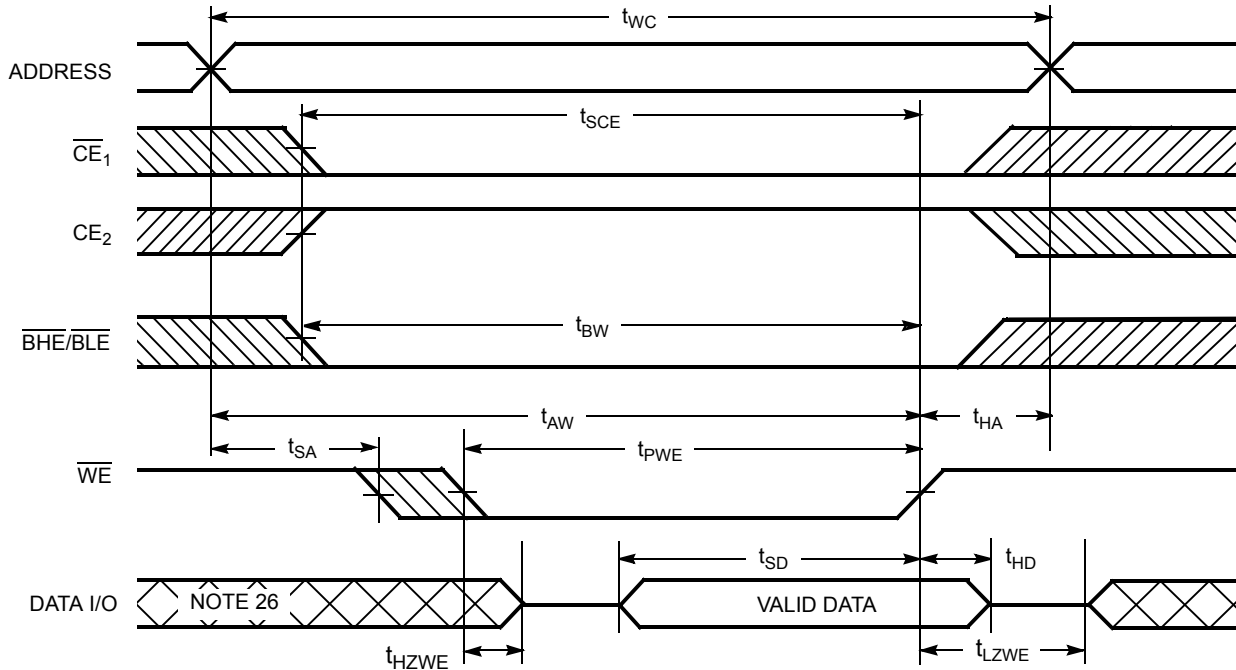
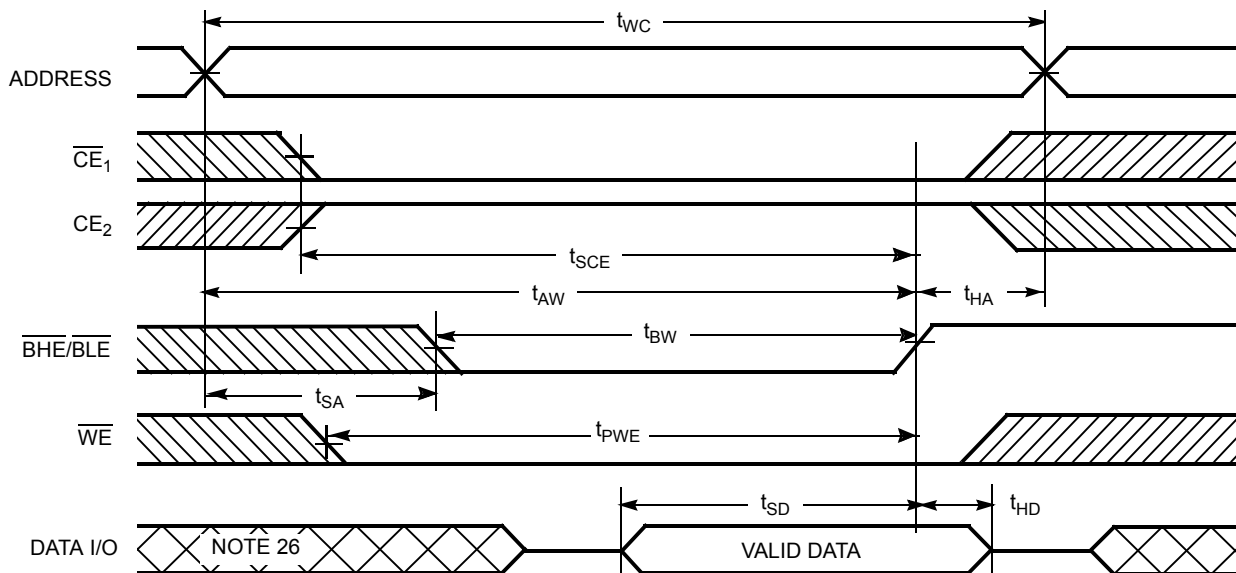

Figure 9. Write Cycle 4:  $\overline{BHE}/\overline{BLE}$  Controlled,  $\overline{OE}$  LOW [25]



Notes

25. If  $\overline{CE}_1$  goes HIGH and  $\overline{CE}_2$  goes LOW simultaneously with  $\overline{WE} = V_{IH}$ , the output remains in a high impedance state.

26. During this period, the I/Os are in output state. Do not apply input signals.

27. The minimum write cycle pulse width should be equal to the sum of  $t_{SD}$  and  $t_{HZWE}$ .

**Truth Table**

$\overline{CE}_1$	$CE_2$	$\overline{WE}$	$\overline{OE}$	$\overline{BHE}$	$\overline{BLE}$	Inputs/Outputs	Mode	Power
H	X	X	X	X	X	High Z	Deselect/Power Down	Standby ( $I_{SB}$ )
X	L	X	X	X	X	High Z	Deselect/Power Down	Standby ( $I_{SB}$ )
L	H	X	X	H	H	High Z	Output Disabled	Active ( $I_{CC}$ )
L	H	H	L	L	L	Data Out ( $I/O_0$ – $I/O_{15}$ )	Read	Active ( $I_{CC}$ )
L	H	H	L	H	L	Data Out ( $I/O_0$ – $I/O_7$ ); High Z ( $I/O_8$ – $I/O_{15}$ )	Read	Active ( $I_{CC}$ )
L	H	H	L	L	H	High Z ( $I/O_0$ – $I/O_7$ ); Data Out ( $I/O_8$ – $I/O_{15}$ )	Read	Active ( $I_{CC}$ )
L	H	H	H	L	H	High Z	Output Disabled	Active ( $I_{CC}$ )
L	H	H	H	H	L	High Z	Output Disabled	Active ( $I_{CC}$ )
L	H	H	H	L	L	High Z	Output Disabled	Active ( $I_{CC}$ )
L	H	L	X	L	L	Data In ( $I/O_0$ – $I/O_{15}$ )	Write	Active ( $I_{CC}$ )
L	H	L	X	H	L	Data In ( $I/O_0$ – $I/O_7$ ); High Z ( $I/O_8$ – $I/O_{15}$ )	Write	Active ( $I_{CC}$ )
L	H	L	X	L	H	High Z ( $I/O_0$ – $I/O_7$ ); Data In ( $I/O_8$ – $I/O_{15}$ )	Write	Active ( $I_{CC}$ )

### Ordering Information

Speed (ns)	Ordering Code	Package Diagram	Package Type	Operating Range
45	CY62156ESL-45BVXI	51-85150	48-ball VFBGA (Pb-free)	Industrial

### Ordering Code Definitions

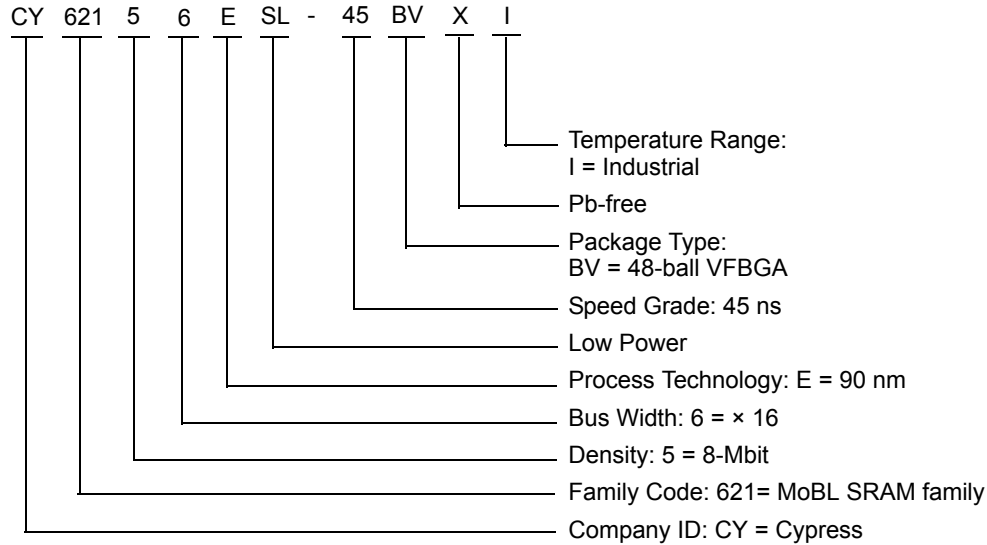

Package Diagrams

Figure 10. 48-ball VFBGA (6 × 8 × 1 mm) BV48/BZ48 Package Outline, 51-85150

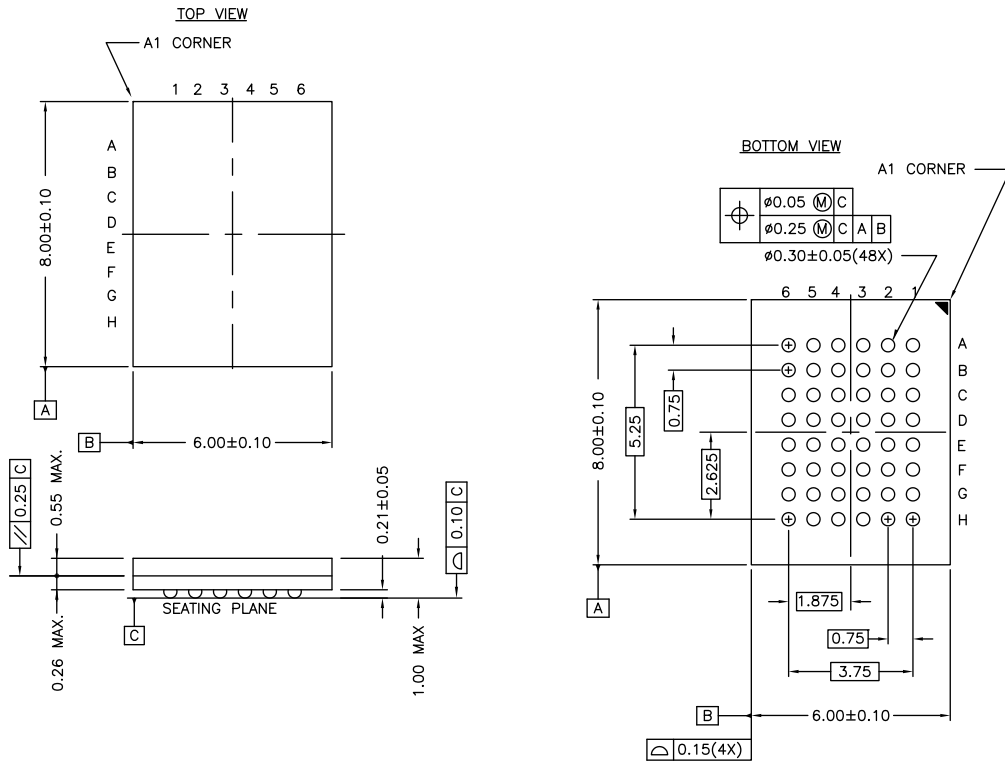

NOTE:  
 PACKAGE WEIGHT: See Cypress Package Material Declaration Datasheet (PMDD)  
 posted on the Cypress web.

51-85150 \*H

## Acronyms

Acronym	Description
$\overline{CE}$	Chip Enable
CMOS	Complementary Metal Oxide Semiconductor
I/O	Input/Output
$\overline{OE}$	Output Enable
RAM	Random Access Memory
SRAM	Static Random Access Memory
VFBGA	Very Fine-Pitch Ball Grid Array
$\overline{WE}$	Write Enable

## Document Conventions

### Units of Measure

Symbol	Unit of Measure
°C	degree Celsius
MHz	megahertz
μA	microampere
μs	microsecond
mA	milliampere
mm	millimeter
ns	nanosecond
Ω	ohm
%	percent
pF	picofarad
V	volt
W	watt

## Document History Page

Document Title: CY62156ESL MoBL <sup>®</sup> , 8-Mbit (512 K × 16) Static RAM Document Number: 001-54995				
Rev.	ECN No.	Orig. of Change	Submission Date	Description of Change
**	2751673	VKN	08/13/09	New data sheet.
*A	2899866	AJU	03/26/10	Removed inactive parts from Ordering Information. Updated Package Diagram.
*B	3109032	AJU	12/13/2010	Obsolete document.
*C	3903222	AJU	02/19/2013	Changed from Obsolete to Active. Removed all references of TSOP packages across the document and added 48-ball VFBGA package related information in the corresponding places. Updated <a href="#">Features</a> . Updated <a href="#">Functional Description</a> . Updated <a href="#">Logic Block Diagram</a> . Updated <a href="#">Ordering Information</a> (Updated part numbers) and added <a href="#">Ordering Code Definitions</a> . Updated <a href="#">Package Diagrams</a> : Removed spec 51-85087 and spec 51-85183. Added spec 51-85150. Added <a href="#">Acronyms</a> and <a href="#">Units of Measure</a> . Updated in new template.
*D	3996550	MEMJ	05/13/2013	Changed status from Preliminary to Final.
*E	4273754	VINI	02/06/2014	Updated in new template. Completing Sunset Review.
*F	4571885	VINI	11/17/2014	Added related documentation hyperlink in page 1. Added Note 17 in <a href="#">Switching Characteristics</a> . Added note reference 17 in the Switching Characteristics table. Added Note 27 in <a href="#">Switching Waveforms</a> . Added note reference 27 in <a href="#">Figure 8</a> .



## Sales, Solutions, and Legal Information

### Worldwide Sales and Design Support

Cypress maintains a worldwide network of offices, solution centers, manufacturer's representatives, and distributors. To find the office closest to you, visit us at [Cypress Locations](#).

#### Products

<a href="#">Automotive</a>	<a href="#">cypress.com/go/automotive</a>
<a href="#">Clocks &amp; Buffers</a>	<a href="#">cypress.com/go/clocks</a>
<a href="#">Interface</a>	<a href="#">cypress.com/go/interface</a>
<a href="#">Lighting &amp; Power Control</a>	<a href="#">cypress.com/go/powerpsoc</a> <a href="#">cypress.com/go/plc</a>
<a href="#">Memory</a>	<a href="#">cypress.com/go/memory</a>
<a href="#">PSoC</a>	<a href="#">cypress.com/go/psoc</a>
<a href="#">Touch Sensing</a>	<a href="#">cypress.com/go/touch</a>
<a href="#">USB Controllers</a>	<a href="#">cypress.com/go/USB</a>
<a href="#">Wireless/RF</a>	<a href="#">cypress.com/go/wireless</a>

#### PSoC® Solutions

[psoc.cypress.com/solutions](#)  
[PSoC 1](#) | [PSoC 3](#) | [PSoC 4](#) | [PSoC 5LP](#)

#### Cypress Developer Community

[Community](#) | [Forums](#) | [Blogs](#) | [Video](#) | [Training](#)

#### Technical Support

[cypress.com/go/support](#)

---

© Cypress Semiconductor Corporation, 2009-2014. The information contained herein is subject to change without notice. Cypress Semiconductor Corporation assumes no responsibility for the use of any circuitry other than circuitry embodied in a Cypress product. Nor does it convey or imply any license under patent or other rights. Cypress products are not warranted nor intended to be used for medical, life support, life saving, critical control or safety applications, unless pursuant to an express written agreement with Cypress. Furthermore, Cypress does not authorize its products for use as critical components in life-support systems where a malfunction or failure may reasonably be expected to result in significant injury to the user. The inclusion of Cypress products in life-support systems application implies that the manufacturer assumes all risk of such use and in doing so indemnifies Cypress against all charges.

Any Source Code (software and/or firmware) is owned by Cypress Semiconductor Corporation (Cypress) and is protected by and subject to worldwide patent protection (United States and foreign), United States copyright laws and international treaty provisions. Cypress hereby grants to licensee a personal, non-exclusive, non-transferable license to copy, use, modify, create derivative works of, and compile the Cypress Source Code and derivative works for the sole purpose of creating custom software and or firmware in support of licensee product to be used only in conjunction with a Cypress integrated circuit as specified in the applicable agreement. Any reproduction, modification, translation, compilation, or representation of this Source Code except as specified above is prohibited without the express written permission of Cypress.

Disclaimer: CYPRESS MAKES NO WARRANTY OF ANY KIND, EXPRESS OR IMPLIED, WITH REGARD TO THIS MATERIAL, INCLUDING, BUT NOT LIMITED TO, THE IMPLIED WARRANTIES OF MERCHANTABILITY AND FITNESS FOR A PARTICULAR PURPOSE. Cypress reserves the right to make changes without further notice to the materials described herein. Cypress does not assume any liability arising out of the application or use of any product or circuit described herein. Cypress does not authorize its products for use as critical components in life-support systems where a malfunction or failure may reasonably be expected to result in significant injury to the user. The inclusion of Cypress' product in a life-support systems application implies that the manufacturer assumes all risk of such use and in doing so indemnifies Cypress against all charges.

Use may be limited by and subject to the applicable Cypress software license agreement.



Компания «ЭлектроПласт» предлагает заключение долгосрочных отношений при поставках импортных электронных компонентов на взаимовыгодных условиях!

Наши преимущества:

- Оперативные поставки широкого спектра электронных компонентов отечественного и импортного производства напрямую от производителей и с крупнейших мировых складов;
- Поставка более 17-ти миллионов наименований электронных компонентов;
- Поставка сложных, дефицитных, либо снятых с производства позиций;
- Оперативные сроки поставки под заказ (от 5 рабочих дней);
- Экспресс доставка в любую точку России;
- Техническая поддержка проекта, помощь в подборе аналогов, поставка прототипов;
- Система менеджмента качества сертифицирована по Международному стандарту ISO 9001;
- Лицензия ФСБ на осуществление работ с использованием сведений, составляющих государственную тайну;
- Поставка специализированных компонентов (Xilinx, Altera, Analog Devices, Intersil, Interpoint, Microsemi, Aeroflex, Peregrine, Syfer, Eurofarad, Texas Instrument, Miteq, Cobham, E2V, MA-COM, Hittite, Mini-Circuits, General Dynamics и др.);

Помимо этого, одним из направлений компании «ЭлектроПласт» является направление «Источники питания». Мы предлагаем Вам помощь Конструкторского отдела:

- Подбор оптимального решения, техническое обоснование при выборе компонента;
- Подбор аналогов;
- Консультации по применению компонента;
- Поставка образцов и прототипов;
- Техническая поддержка проекта;
- Защита от снятия компонента с производства.



#### Как с нами связаться

**Телефон:** 8 (812) 309 58 32 (многоканальный)

**Факс:** 8 (812) 320-02-42

**Электронная почта:** [org@eplast1.ru](mailto:org@eplast1.ru)

**Адрес:** 198099, г. Санкт-Петербург, ул. Калинина, дом 2, корпус 4, литера А.