

REVISIONS					
P	LTN	DESCRIPTION	DATE	DMN	APVD
V		REDRAWN /REVISED PER ECO-17-001745	22NOV2017	KS	JO

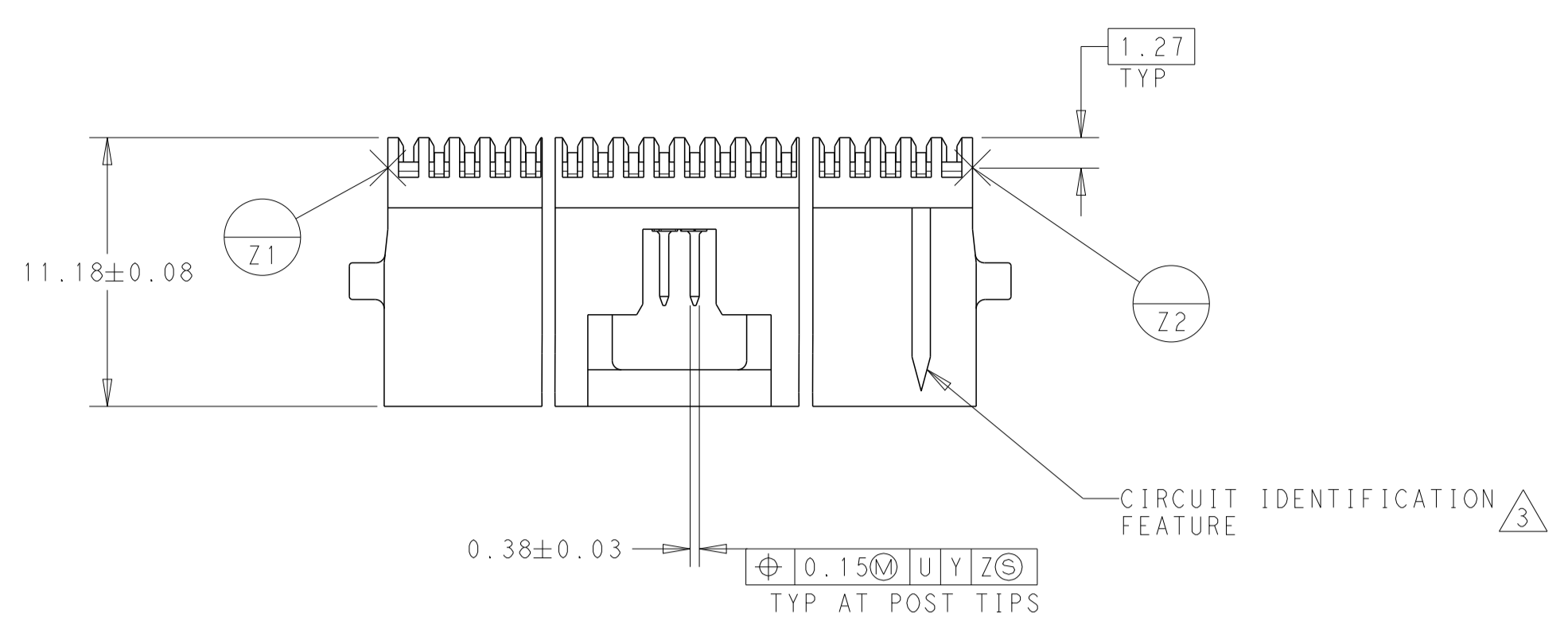

- △ CONTACT AREAS PLATED WITH 0.76μm GOLD, SOLDER TAILS PLATED WITH 3.81μm TIN-LEAD, ALL OVER 1.27μm NICKEL
- 2. NOTE DELETED.
- △ CIRCUIT IDENTIFICATION FEATURE OMITTED ON 4, 5, 6, & 7 POSITION HEADER ASSEMBLIES
- △ DIMENSION APPLIES AT BASE OF SHROUD
- △ THE NOTED DIMENSIONS APPLY AT THE INTERSECTION OF THE POST AND HOUSING
- △ CONTACT AREAS PLATED WITH 0.76μm GOLD, SOLDER TAILS PLATED WITH 3.81μm TIN, ALL OVER 1.27μm NICKEL.
- △ MATERIAL: HOUSING-LCP, COLOR-BLACK
CONTACT-COPPER ALLOY
- △ FINISH: 0.03μm MIN GOLD ON GOLD PLATED AREA, 3.81μm MATTE TIN-LEAD ON TIN PLATED AREA. UNDER PLATING TO BE 1.27μm NICKEL ON ENTIRE CONTACT
- △ FINISH: 0.03μm MIN GOLD ON GOLD PLATED AREA, 3.81μm MATTE TIN ON TIN PLATED AREA. UNDER PLATING TO BE 1.27μm NICKEL ON ENTIRE CONTACT.
- 10. NOTE DELETED.
- 11. NOTE DELETED.
- 12. NOTE DELETED.
- 13. NOTE DELETED.

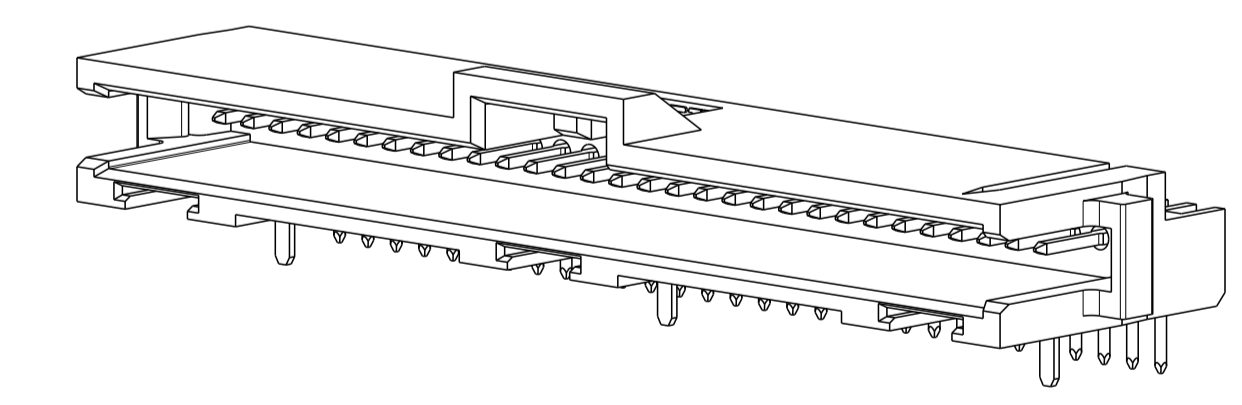
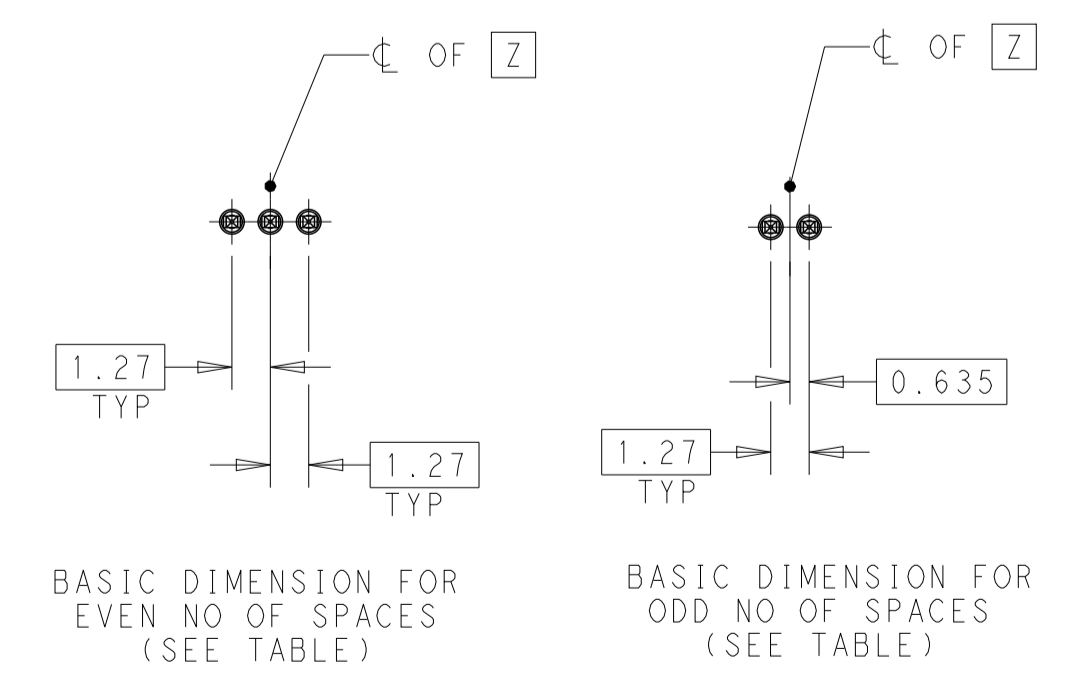
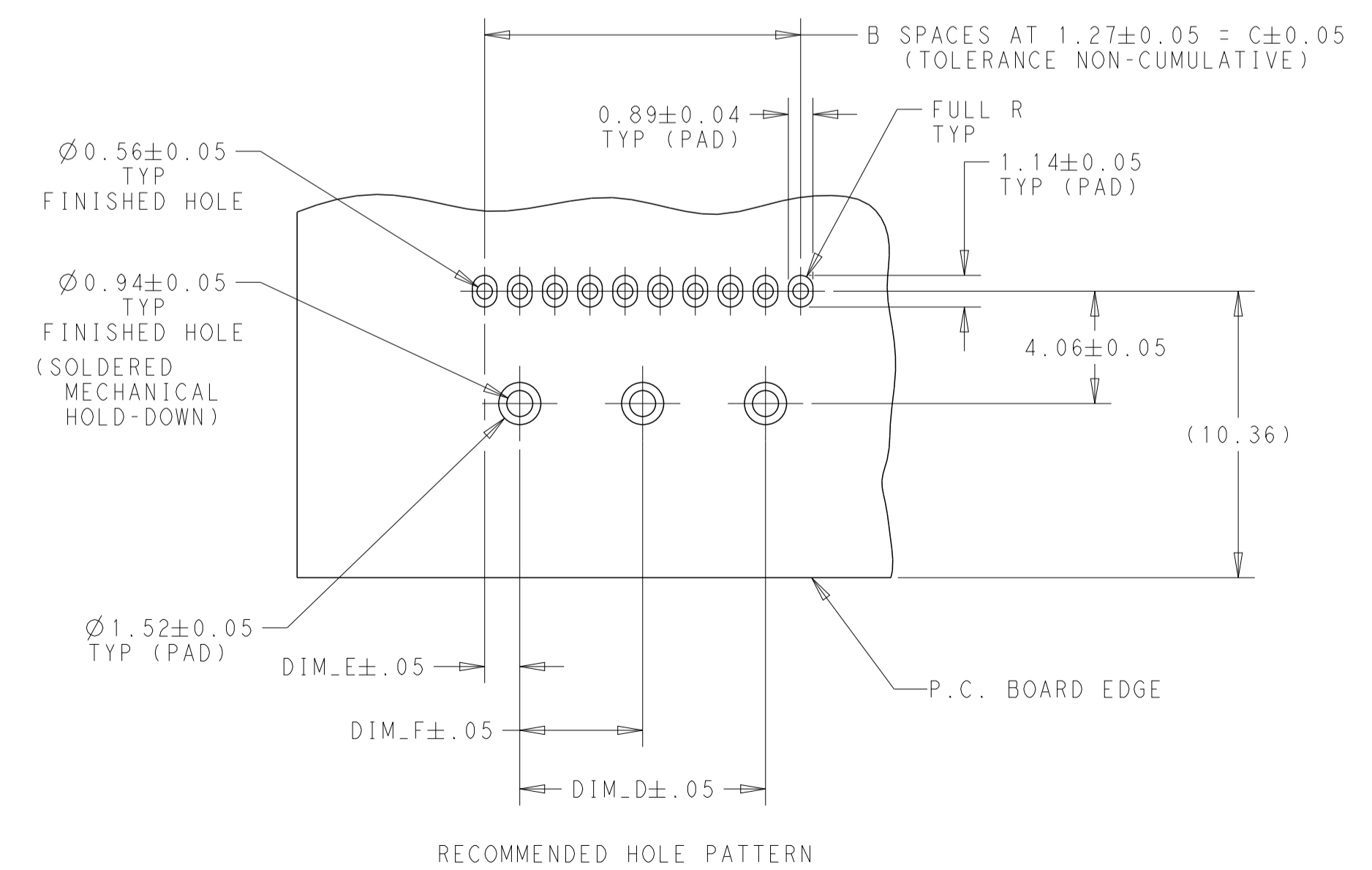
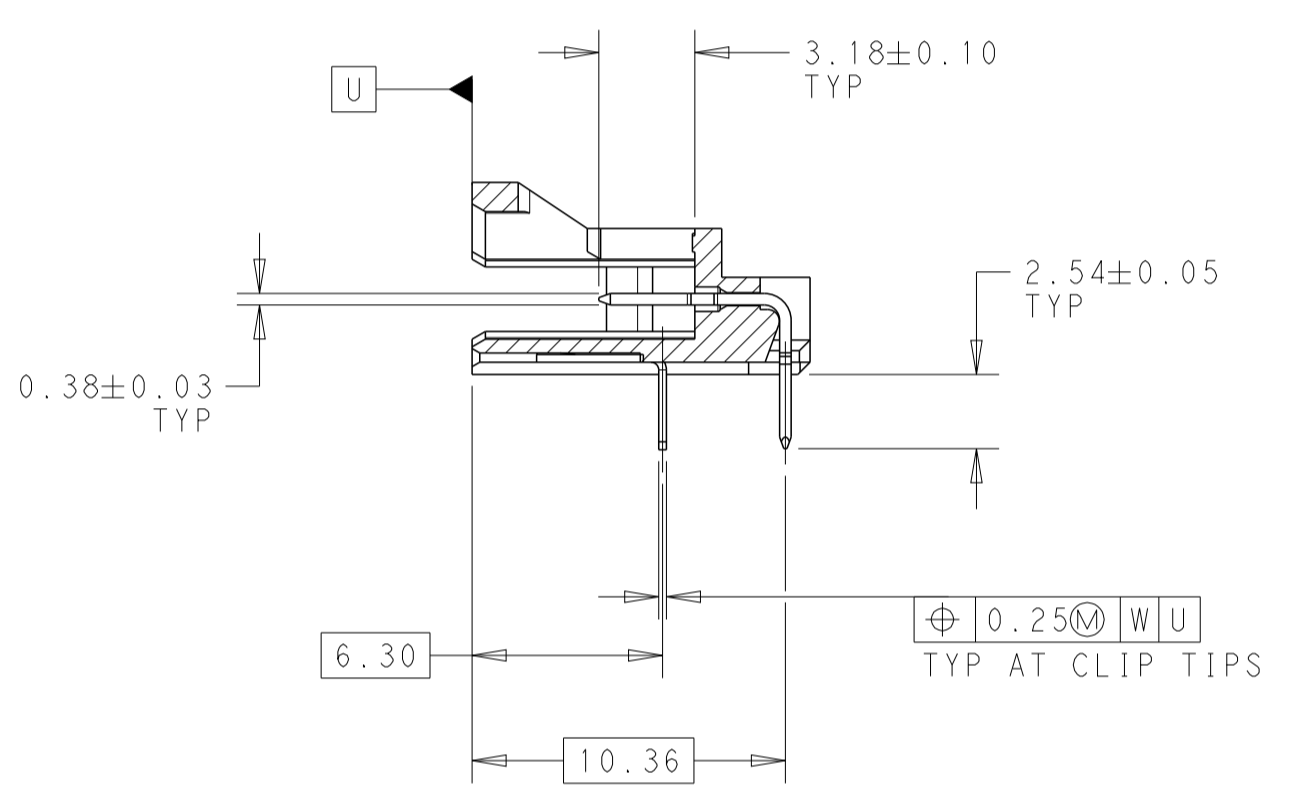
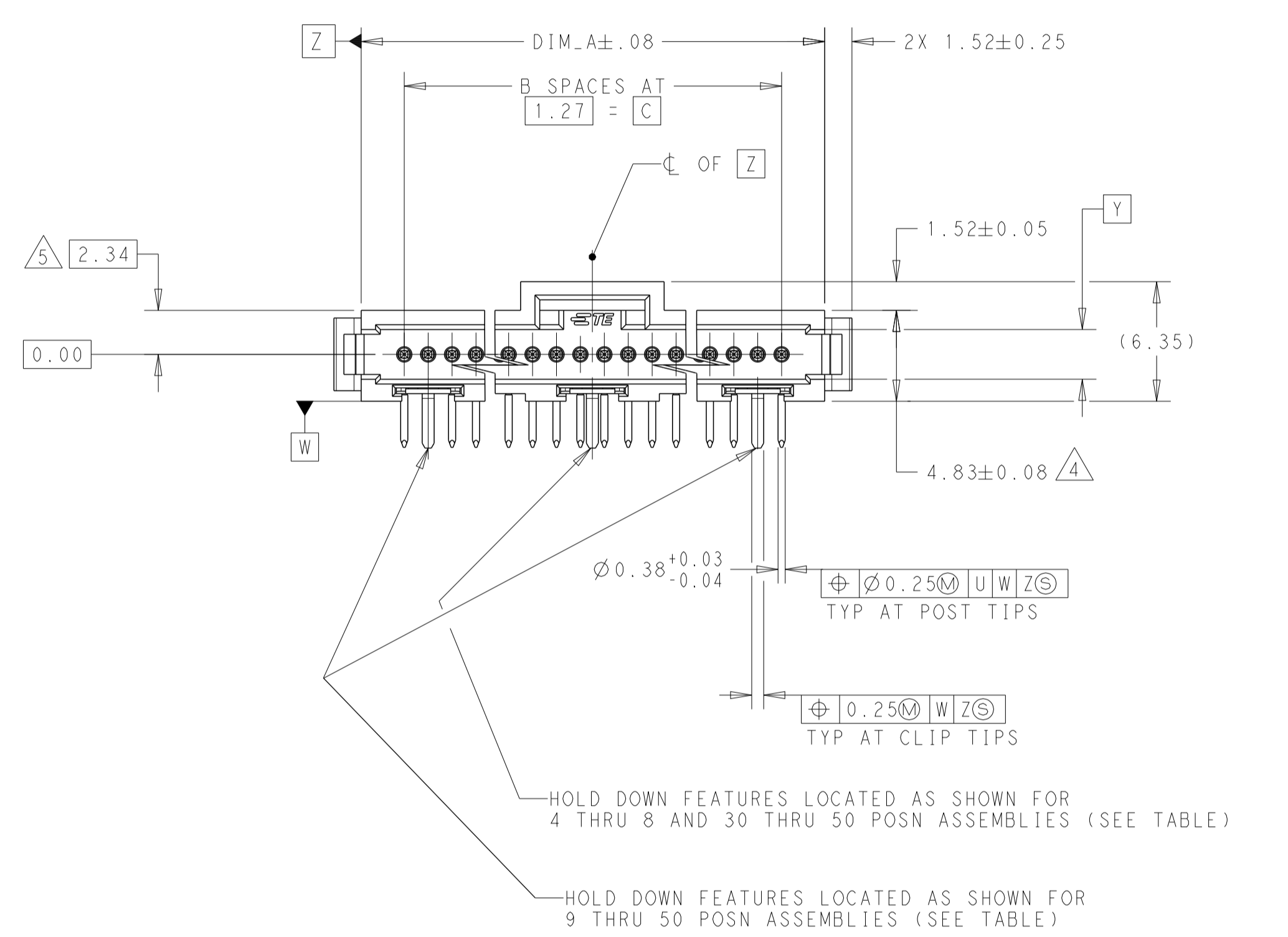

THIS DRAWING IS A CONTROLLED DOCUMENT.		DMN: R. SHRISHAILI 22NOV2017	TE Connectivity NAME: HEADER ASSEMBLY, RIGHT ANGLE, SINGLE ROW, W/SIDE & END LATCHES, AMPMODU SYSTEM 50	
DIMENSIONS:		CHK: J. OLSON 22NOV2017		
TOLERANCES UNLESS OTHERWISE SPECIFIED:		APVD: J. OLSON 22NOV2017	PRODUCT SPEC: 108-1093	
0 PLC ±.3 1 PLC ±0.3 2 PLC ±0.13 3 PLC ±. 4 PLC ±. ANGLES ±0.5°		APPLICATION SPEC: 114-25031	SIZE: A1	
MATERIAL: SEE TABLE		WEIGHT: C=104074	RESTRICTED TO: -	
CUSTOMER DRAWING			SCALE: 4:1 SHEET 1 OF 2 REV V	

REVISIONS				
P	LTN	DESCRIPTION	DATE	APPD
-		SEE SHEET 1	-	-

	15.87	1.27	31.75	34.29	27	38.86	28	9-104074-0
	29.84	1.27	59.69	62.23	49	66.80	50	8-104074-9
	26.67	1.27	53.34	55.88	44	60.45	45	8-104074-8
	23.49	1.27	46.99	49.53	39	54.10	40	8-104074-7
	20.95	1.27	41.91	44.45	35	49.02	36	8-104074-6
	15.24	1.27	30.48	33.02	26	37.59	27	8-104074-5
	-	1.27	24.13	26.67	21	31.24	22	8-104074-4
	-	1.27	17.78	20.32	16	24.89	17	8-104074-3
	-	1.27	12.70	15.24	12	19.81	13	8-104074-2
	-	1.27	11.43	13.97	11	18.54	12	8-104074-1
	-	4.44	-	8.89	7	13.46	8	8-104074-0
	-	3.81	-	7.62	6	12.19	7	7-104074-9
	-	3.17	-	6.35	5	10.92	6	7-104074-8
	-	1.90	-	3.81	3	8.38	4	7-104074-7
	17.14	1.27	34.29	36.83	29	41.40	30	7-104074-6
	-	1.27	27.94	30.48	24	35.05	25	7-104074-5
	-	1.27	21.59	24.13	19	28.70	20	7-104074-4
	-	1.27	15.24	17.78	14	22.35	15	7-104074-3
	-	2.54	-	5.08	4	9.65	5	7-104074-2
	-	1.27	8.89	11.43	9	16.00	10	7-104074-1
	15.87	1.27	31.75	34.29	27	38.86	28	7-104074-0
	29.84	1.27	59.69	62.23	49	66.80	50	6-104074-9
	26.67	1.27	53.34	55.88	44	60.45	45	6-104074-8
	23.49	1.27	46.99	49.53	39	54.10	40	6-104074-7
	20.95	1.27	41.91	44.45	35	49.02	36	6-104074-6
	15.24	1.27	30.48	33.02	26	37.59	27	6-104074-5
	-	1.27	24.13	26.67	21	31.24	22	6-104074-4
	-	1.27	17.78	20.32	16	24.89	17	6-104074-3
	-	1.27	12.70	15.24	12	19.81	13	6-104074-2
	-	1.27	11.43	13.97	11	18.54	12	6-104074-1
	-	4.44	-	8.89	7	13.46	8	6-104074-0
	-	3.81	-	7.62	6	12.19	7	5-104074-9
	-	3.17	-	6.35	5	10.92	6	5-104074-8
	-	1.90	-	3.81	3	8.38	4	5-104074-7
	17.14	1.27	34.29	36.83	29	41.40	30	5-104074-6
	-	1.27	27.94	30.48	24	35.05	25	5-104074-5
	-	1.27	21.59	24.13	19	28.70	20	5-104074-4
	-	1.27	15.24	17.78	14	22.35	15	5-104074-3
	-	2.54	-	5.08	4	9.65	5	5-104074-2
	-	1.27	8.89	11.43	9	16.00	10	5-104074-1
FINSH	DIM_F	DIM_E	DIM_D	DIM_C	B SPACES	DIM_A	NO OF POSN	PART NUMBER

	15.87	1.27	31.75	34.29	27	38.86	28	4-104074-0
	29.84	1.27	59.69	62.23	49	66.80	50	3-104074-9
	26.67	1.27	53.34	55.88	44	60.45	45	3-104074-8
	23.49	1.27	46.99	49.53	39	54.10	40	3-104074-7
	20.95	1.27	41.91	44.45	35	49.02	36	3-104074-6
	15.24	1.27	30.48	33.02	26	37.59	27	3-104074-5
	-	1.27	24.13	26.67	21	31.24	22	3-104074-4
	-	1.27	17.78	20.32	16	24.89	17	3-104074-3
	-	1.27	12.70	15.24	12	19.81	13	3-104074-2
	-	1.27	11.43	13.97	11	18.54	12	3-104074-1
	-	4.44	-	8.89	7	13.46	8	3-104074-0
	-	3.81	-	7.62	6	12.19	7	2-104074-9
	-	3.17	-	6.35	5	10.92	6	2-104074-8
	-	1.90	-	3.81	3	8.38	4	2-104074-7
	17.14	1.27	34.29	36.83	29	41.40	30	2-104074-6
	-	1.27	27.94	30.48	24	35.05	25	2-104074-5
	-	1.27	21.59	24.13	19	28.70	20	2-104074-4
	-	1.27	15.24	17.78	14	22.35	15	2-104074-3
	-	2.54	-	5.08	4	9.65	5	2-104074-2
	-	1.27	8.89	11.43	9	16.00	10	2-104074-1
	15.87	1.27	31.75	34.29	27	38.86	28	2-104074-0
	29.84	1.27	59.69	62.23	49	66.8	50	1-104074-9
	26.67	1.27	53.34	55.88	44	60.45	45	1-104074-8
	23.49	1.27	46.99	49.53	39	54.10	40	1-104074-7
	20.95	1.27	41.91	44.45	35	49.02	36	1-104074-6
	15.24	1.27	30.48	33.02	26	37.59	27	1-104074-5
	-	1.27	24.13	26.67	21	31.24	22	1-104074-4
	-	1.27	17.78	20.32	16	24.89	17	1-104074-3
	-	1.27	12.70	15.24	12	19.81	13	1-104074-2
	-	1.27	11.43	13.97	11	18.54	12	1-104074-1
	-	4.44	-	8.89	7	13.46	8	1-104074-0
	-	3.81	-	7.62	6	12.19	7	104074-9
	-	3.17	-	6.35	5	10.92	6	104074-8
	-	1.90	-	3.81	3	8.38	4	104074-7
	17.14	1.27	34.29	36.83	29	41.40	30	104074-6
	-	1.27	27.94	30.48	24	35.05	25	104074-5
	-	1.27	21.59	24.13	19	28.70	20	104074-4
	-	1.27	15.24	17.78	14	22.35	15	104074-3
	-	2.54	-	5.08	4	9.65	5	104074-2
	-	1.27	8.89	11.43	9	16.00	10	104074-1
FINSH	DIM_F	DIM_E	DIM_D	DIM_C	B SPACES	DIM_A	NO OF POSN	PART NUMBER

THIS DRAWING IS A CONTROLLED DOCUMENT. DWN R. SHRISHAIL 22NOV2017
 CHK J. OLSON 22NOV2017

DIMENSIONS: mm TOLERANCES UNLESS OTHERWISE SPECIFIED:
 0 PLC ±
 1 PLC ±0.3
 2 PLC ±0.13
 3 PLC ±
 4 PLC ±
 ANGLES ±0.5°
 FINISH SEE TABLE

MATERIAL WEIGHT 114-25031

CUSTOMER DRAWING

APVD J. OLSON 22NOV2017

PRODUCT SPEC 108-1093

APPLICATION SPEC

NAME HEADER ASSEMBLY, RIGHT ANGLE, SINGLE ROW, W/SIDE & END LATCHES AMPMODU SYSTEM 50

SIZE A1 CAGE CODE - DRAWING NO. C=104074 RESTRICTED TO

SCALE 4:1 SHEET 2 OF 2 REV V

TE Connectivity



Компания «ЭлектроПласт» предлагает заключение долгосрочных отношений при поставках импортных электронных компонентов на взаимовыгодных условиях!

Наши преимущества:

- Оперативные поставки широкого спектра электронных компонентов отечественного и импортного производства напрямую от производителей и с крупнейших мировых складов;
- Поставка более 17-ти миллионов наименований электронных компонентов;
- Поставка сложных, дефицитных, либо снятых с производства позиций;
- Оперативные сроки поставки под заказ (от 5 рабочих дней);
- Экспресс доставка в любую точку России;
- Техническая поддержка проекта, помощь в подборе аналогов, поставка прототипов;
- Система менеджмента качества сертифицирована по Международному стандарту ISO 9001;
- Лицензия ФСБ на осуществление работ с использованием сведений, составляющих государственную тайну;
- Поставка специализированных компонентов (Xilinx, Altera, Analog Devices, Intersil, Interpoint, Microsemi, Aeroflex, Peregrine, Syfer, Eurofarad, Texas Instrument, Miteq, Cobham, E2V, MA-COM, Hittite, Mini-Circuits, General Dynamics и др.);

Помимо этого, одним из направлений компании «ЭлектроПласт» является направление «Источники питания». Мы предлагаем Вам помощь Конструкторского отдела:

- Подбор оптимального решения, техническое обоснование при выборе компонента;
- Подбор аналогов;
- Консультации по применению компонента;
- Поставка образцов и прототипов;
- Техническая поддержка проекта;
- Защита от снятия компонента с производства.



Как с нами связаться

Телефон: 8 (812) 309 58 32 (многоканальный)

Факс: 8 (812) 320-02-42

Электронная почта: org@eplast1.ru

Адрес: 198099, г. Санкт-Петербург, ул. Калинина, дом 2, корпус 4, литера А.