

## 200 mA LOAD SWITCH FEATURING PRE-BIASED PNP TRANSISTOR AND N-MOSFET WITH PULL DOWN RESISTOR

NEW PRODUCT

### General Description

- LMN200B01 is best suited for applications where the load needs to be turned on and off using control circuits like micro-controllers, comparators, etc., particularly at a point of load. It features a discrete pass transistor with stable  $V_{CE(SAT)}$  which does not depend on the input voltage and can support continuous maximum current of 200 mA. It also contains a discrete N-MOSFET that can be used as control. This N-MOSFET also has a built-in pull down resistor at its gate. The component can be used as a part of a circuit or as a stand alone discrete device.

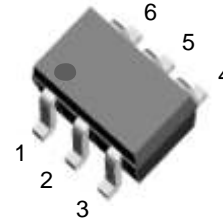

Fig. 1: SOT-26

### Features

- Voltage Controlled Small Signal Switch
- N-MOSFET with Gate Pull-Down Resistor
- Surface Mount Package
- Ideally Suited for Automated Assembly Processes
- Lead Free By Design/ROHS Compliant (Note 1)**
- "Green" Device (Note 2)**

### Mechanical Data

- Case: SOT-26
- Case Material: Molded Plastic, "Green" Molding Compound. UL Flammability Classification Rating 94V-0
- Moisture sensitivity: Level 1 per J-STD-020C
- Terminal Connections: See Diagram
- Terminals: Finish - Matte Tin annealed over Copper leadframe. Solderable per MIL-STD-202, Method 208
- Marking & Type Code Information: See Last Page
- Ordering Information: See Last Page
- Weight: 0.016 grams (approximate)

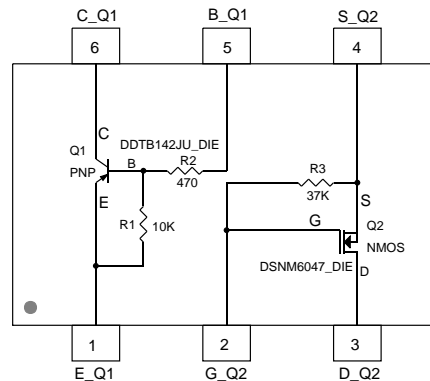

Fig. 2 Schematic and Pin Configuration

Sub-Components	Reference	Device Type	R1 (NOM)	R2 (NOM)	R3 (NOM)	Figure
DDTB142JU_DIE	Q1	PNP Transistor	10K	470		2
DSNM6047_DIE	Q2	N-MOSFET			37K	2

### Maximum Ratings, Total Device @ $T_A = 25^\circ\text{C}$ unless otherwise specified

Characteristic	Symbol	Value	Unit
Power Dissipation (Note 3)	$P_d$	300	mW
Power Derating Factor above $125^\circ\text{C}$	$P_{der}$	2.4	mW/ $^\circ\text{C}$
Output Current	$I_{out}$	200	mA

### Thermal Characteristics

Characteristic	Symbol	Value	Unit
Junction Operation and Storage Temperature Range	$T_j, T_{stg}$	-55 to +150	$^\circ\text{C}$
Thermal Resistance, Junction to Ambient Air (Note3) (Equivalent to one heated junction of PNP transistor)	$R_{JA}$	417	$^\circ\text{C/W}$

- Notes:
- No purposefully added lead.
  - Diodes Inc.'s "Green" policy can be found on our website at [http://www.diodes.com/products/lead\\_free/index.php](http://www.diodes.com/products/lead_free/index.php).
  - Device mounted on FR-4 PCB, 1 inch x 0.85 inch x 0.062 inch; pad layout as shown on Diodes Inc. suggested pad layout document AP02001, which can be found on our website at <http://www.diodes.com/datasheets/ap02001.pdf>.

**Maximum Ratings:**
**Sub-Component Device: Pre-Biased PNP Transistor (Q1)** @  $T_A = 25^\circ\text{C}$  unless otherwise specified

Characteristic	Symbol	Value	Unit
Collector-Base Voltage	$V_{CBO}$	-50	V
Collector-Emitter Voltage	$V_{CEO}$	-50	V
Supply Voltage	$V_{CC}$	-50	V
Input Voltage	$V_{in}$	+5 to -6	V
Output Current	$I_C$	-200	mA

**Sub-Component Device:**
**N-MOSFET with Gate Pull-Down Resistor (Q2)** @  $T_A = 25^\circ\text{C}$  unless otherwise specified

Characteristic	Symbol	Value	Unit
Drain-Source Voltage	$V_{BSS}$	60	V
Drain Gate Voltage ( $R_{GS} = 1M \Omega$ )	$V_{DGR}$	60	V
Gate-Source Voltage	$V_{GSS}$	Continuous	+/-20
		Pulsed ( $t_p < 50 \mu\text{s}$ )	+/-40
Drain Current (Page 1: Note 3)	$I_D$	Continuous ( $V_{GS} = 10\text{V}$ )	115
		Pulsed ( $t_p < 10 \mu\text{s}$ , Duty Cycle <1%)	800
Continuous Source Current	$I_S$	115	mA

**Electrical Characteristics: Pre-Biased PNP Transistor (Q1) @  $T_A = 25^\circ\text{C}$  unless otherwise specified**

Characteristic	Symbol	Min	Typ	Max	Unit	Test Condition
<b>OFF CHARACTERISTICS</b>						
Collector-Base Cut Off Current	$I_{CBO}$			-100	nA	$V_{CB} = -50\text{V}, I_E = 0$
Collector-Emitter Cut Off Current	$I_{CEO}$			-500	nA	$V_{CE} = -50\text{V}, I_B = 0$
Emitter-Base Cut Off Current	$I_{EBO}$		-0.5	-1	mA	$V_{EB} = -5\text{V}, I_C = 0$
Emitter-Base Cut Off Current	$V_{(BR)CBO}$	-50			V	$I_C = -10\mu\text{A}, I_E = 0$
Collector-Base Breakdown Voltage	$V_{(BR)CEO}$	-50			V	$I_C = -2\text{mA}, I_B = 0$
Collector-Emitter Breakdown Voltage	$V_{I(OFF)}$		-0.55	-0.3	V	$V_{CE} = -5\text{V}, I_C = -100\mu\text{A}$
Output Voltage	$V_{OH}$	-4.9			V	$V_{CC} = -5\text{V}, V_B = -0.05\text{V}, R_L = 1\text{K}$
Output Current (leakage current same as $I_{CEO}$ )	$I_{O(OFF)}$			-500	nA	$V_{CC} = -50\text{V}, V_I = 0\text{V}$
<b>ON CHARACTERISTICS</b>						
Collector-Emitter Saturation Voltage	$V_{CE(SAT)}$			-0.15	V	$I_C = -10\text{mA}, I_B = -0.5\text{mA}$
				-0.2	V	$I_C = -50\text{mA}, I_B = -5\text{mA}$
				-0.2	V	$I_C = -20\text{mA}, I_B = -1\text{mA}$
				-0.25	V	$I_C = -100\text{mA}, I_B = -10\text{mA}$
				-0.25	V	$I_C = -200\text{mA}, I_B = -10\text{mA}$
				-0.3	V	$I_C = -200\text{mA}, I_B = -20\text{mA}$
Equivalent on-resistance*	$R_{CE(SAT)}$			1.5		$I_C = -200\text{mA}, I_B = -10\text{mA}$
DC Current Gain	$h_{FE}$	60	150			$V_{CE} = -5\text{V}, I_C = -20\text{mA}$
		60	215			$V_{CE} = -5\text{V}, I_C = -50\text{mA}$
		60	245			$V_{CE} = -5\text{V}, I_C = -100\text{mA}$
		60	250			$V_{CE} = -5\text{V}, I_C = -200\text{mA}$
Input On Voltage	$V_{I(ON)}$	-2.45	-0.7		V	$V_O = -0.3\text{V}, I_C = -2\text{mA}$
Output Voltage (equivalent to $V_{CE(SAT)}$ or $V_{O(on)}$ )	$V_{OL}$		-0.065	-0.15	V	$V_{CC} = -5\text{V}, V_B = -2.5\text{V}, I_O/I_I = -50\text{mA} / -2.5\text{mA}$
Input Current	$I_i$		-9.2	-13	mA	$V_I = -5\text{V}$
Base-Emitter Turn-on Voltage	$V_{BE(ON)}$		-1.125	-1.3	V	$V_{CE} = -5\text{V}, I_C = -200\text{mA}$
Base-Emitter Saturation Voltage	$V_{BE(SAT)}$		-3.2	-3.6	V	$I_C = -50\text{mA}, I_B = -5\text{mA}$
			-4.55	-5.5		$I_C = -80\text{mA}, I_B = -8\text{mA}$
Input Resistor (Base), +/- 30%	R2		0.47		K	
Pull-up Resistor (Base to $V_{CC}$ supply), +/- 30%	R1		10		K	
Resistor Ratio (Input Resistor/Pullup resistor), +/- 20%	R1/R2		21			
<b>SMALL SIGNAL CHARACTERISTICS</b>						
Transition Frequency (gain bandwidth product)	$f_T$		200		MHz	$V_{CE} = -10\text{V}, I_E = -5\text{mA}, f = 100\text{MHz}$
Collector capacitance, ( $C_{cbo}$ -Output Capacitance)	$C_C$		20		pF	$V_{CB} = -10\text{V}, I_E = 0\text{A}, f = 1\text{MHz}$

\* Pulse Test: Pulse width,  $t_p < 300\ \mu\text{s}$ , Duty Cycle,  $d < 0.02$ .

**Electrical Characteristics:**

**N-MOSFET with Gate Pull-Down Resistor (Q2) @ T<sub>A</sub> = 25°C unless otherwise specified**

Characteristic	Symbol	Min	Typ	Max	Unit	Test Condition
<b>OFF CHARACTERISTICS (Note 4)</b>						
Drain-Source Breakdown Voltage, BVDSS	V <sub>(BR)DSS</sub>	60			V	V <sub>GS</sub> = 0V, I <sub>D</sub> = 10μA
Zero Gate Voltage Drain Current (Drain Leakage Current)	I <sub>DSS</sub>			1	μA	V <sub>GS</sub> = 0V, V <sub>DS</sub> = 60V
Gate-Body Leakage Current, Forward	I <sub>GSSF</sub>			0.95	mA	V <sub>GS</sub> = 20V, V <sub>DS</sub> = 0V
Gate-Body Leakage Current, Reverse	I <sub>GSSR</sub>			-0.95	mA	V <sub>GS</sub> = -20V, V <sub>DS</sub> = 0V
<b>ON CHARACTERISTICS (Note 4)</b>						
Gate Source Threshold Voltage (Control Supply Voltage)	V <sub>GS(th)</sub>	1	1.86	2.2	V	V <sub>DS</sub> = V <sub>GS</sub> , I <sub>D</sub> = 0.25mA
Static Drain-Source On-State Voltage	V <sub>DS(on)</sub>		0.08	1.5	V	V <sub>GS</sub> = 5V, I <sub>D</sub> = 50mA
			0.15	3.75		V <sub>GS</sub> = 10V, I <sub>D</sub> = 115mA
On-State Drain Current	I <sub>D(on)</sub>	500			mA	V <sub>GS</sub> = 10V, V <sub>DS</sub> = 2 V <sub>DS(on)</sub>
Static Drain-Source On Resistance	R <sub>DS(on)</sub>		1.55	3		V <sub>GS</sub> = 5V, I <sub>D</sub> = 50mA
			1.4	2		V <sub>GS</sub> = 10V, I <sub>D</sub> = 500mA
Forward Transconductance	g <sub>FS</sub>	80	240		mS	V <sub>DS</sub> = 2 V <sub>DS(on)</sub> , I <sub>D</sub> = 115 mA
		80	350			V <sub>DS</sub> = 2 V <sub>DS(on)</sub> , I <sub>D</sub> = 200 mA
Gate Pull-Down Resistor, +/- 30%	R3		37		K	
<b>DYNAMIC CHARACTERISTICS</b>						
Input Capacitance	C <sub>iss</sub>			50	pF	V <sub>DS</sub> = -25V, V <sub>GS</sub> = 0V, f = 1MHz
Output Capacitance	C <sub>oss</sub>			25	pF	
Reverse Transfer Capacitance	C <sub>rss</sub>			5	pF	
<b>SWITCHING CHARACTERISTICS*</b>						
Turn-On Delay Time	t <sub>d(on)</sub>			20	ns	V <sub>DD</sub> = 30V, V <sub>GS</sub> = 10V, I <sub>D</sub> = 200mA, R <sub>G</sub> = 25 Ω, R <sub>L</sub> = 150 Ω
Turn-Off Delay Time	t <sub>d(off)</sub>			40	ns	
<b>SOURCE-DRAIN (BODY) DIODE CHARACTERISTICS AND MAXIMUM RATINGS</b>						
Drain-Source Diode Forward On-Voltage	V <sub>SD</sub>		0.88	1.5	V	V <sub>GS</sub> = 0V, I <sub>S</sub> = 115 mA*
Maximum Continuous Drain-Source Diode Forward Current (Reverse Drain Current)	I <sub>S</sub>			115	mA	
Maximum Pulsed Drain-Source Diode Forward Current	I <sub>SM</sub>			800	mA	

\* Pulse Test: Pulse width, t<sub>p</sub> < 300 μs, Duty Cycle, d <= 0.02.

Notes: 4. Short duration test pulse used to minimize self-heating effect.

Typical Characteristics

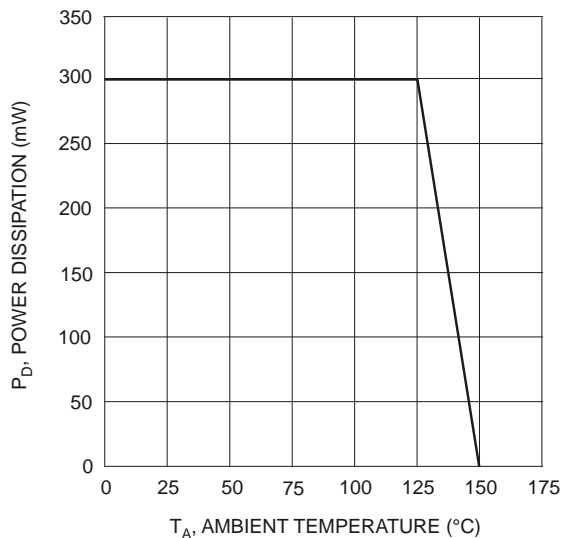

Fig. 3, Max Power Dissipation vs Ambient Temperature

Typical Pre-Biased PNP Transistor (Q1) Characteristics

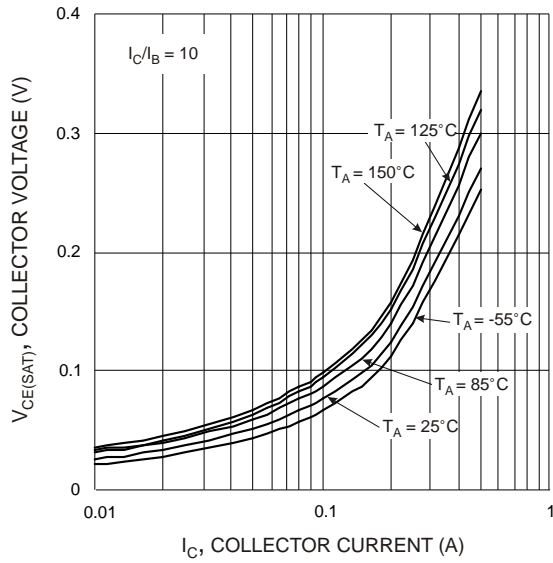

Fig. 4  $V_{CE(SAT)}$  vs.  $I_C$

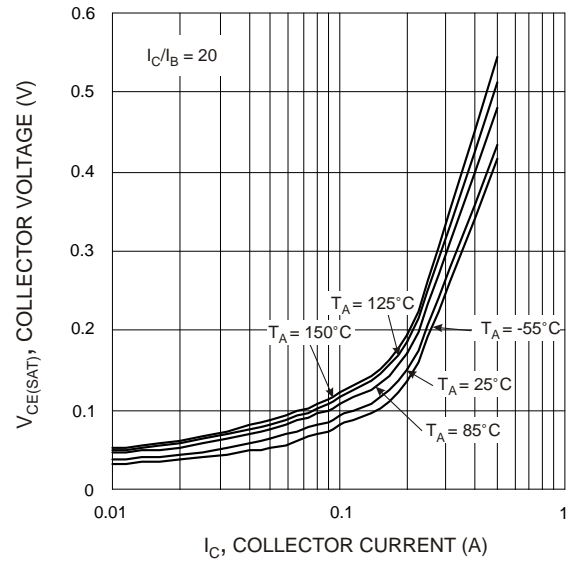

Fig. 5  $V_{CE(SAT)}$  vs.  $I_C$

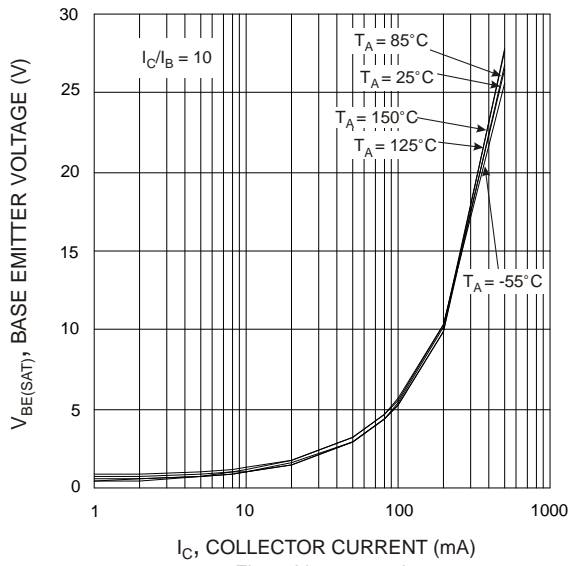

Fig. 6  $V_{BE(SAT)}$  vs.  $I_C$

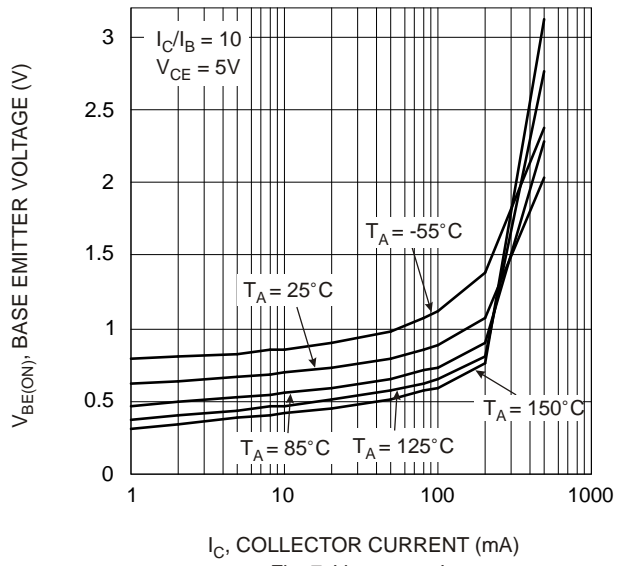

Fig. 7  $V_{BE(ON)}$  vs.  $I_C$

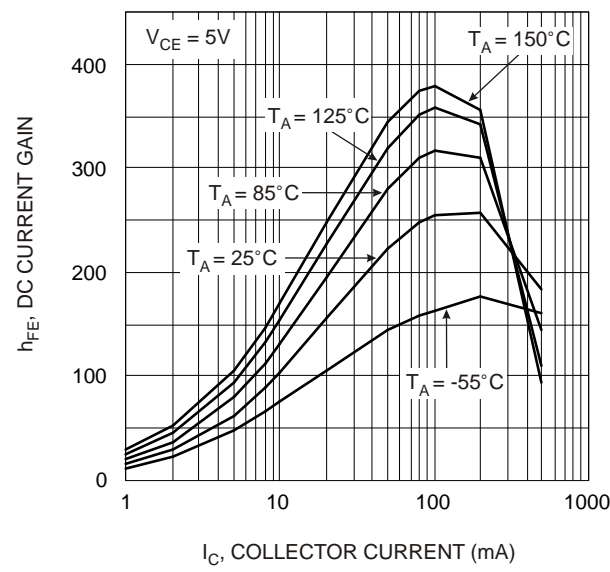
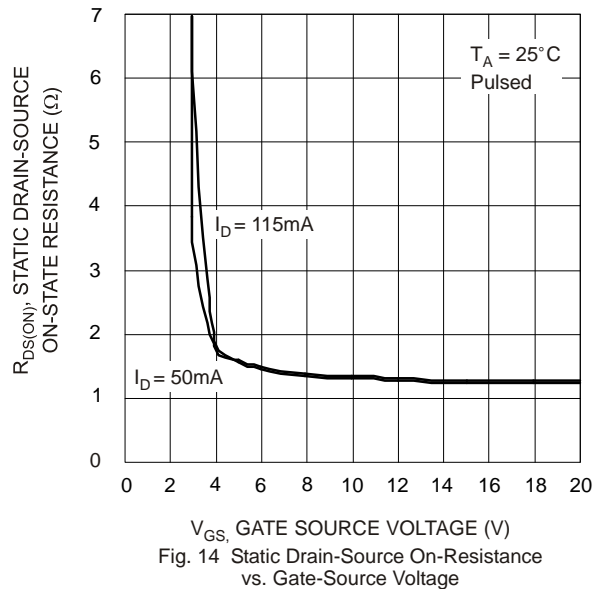
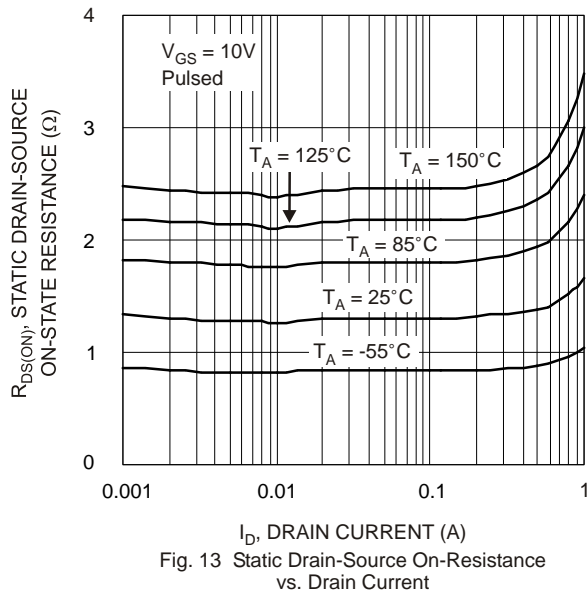
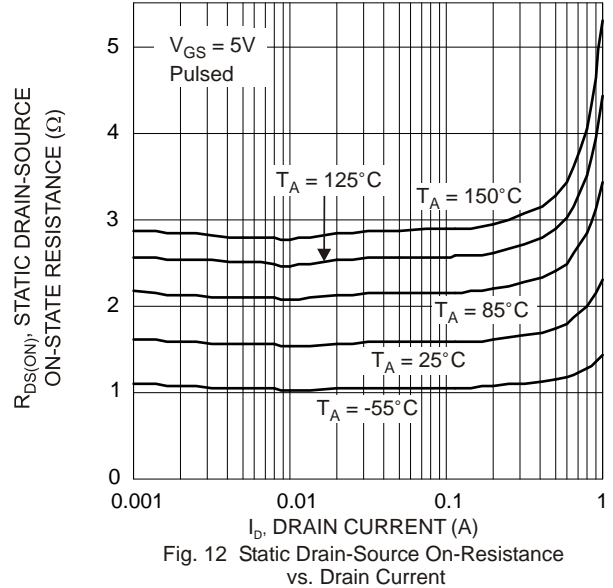
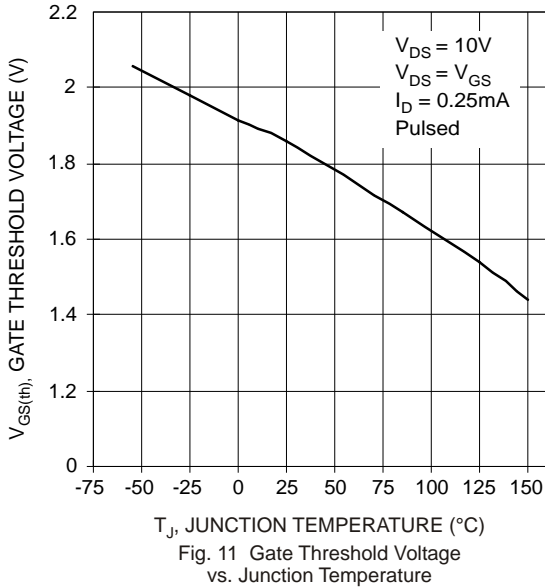
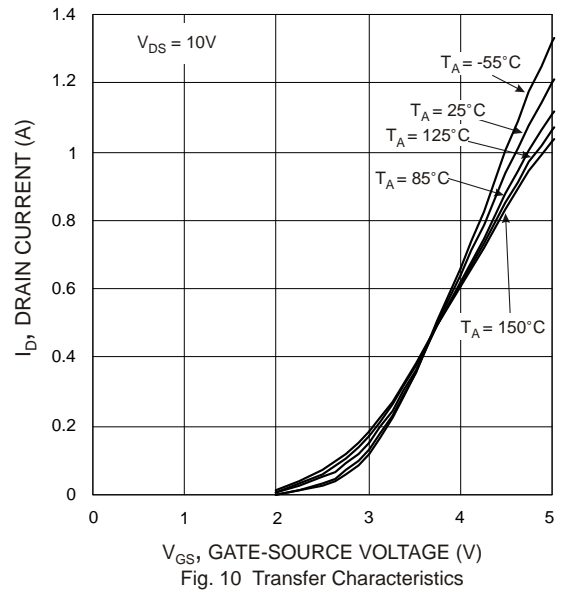
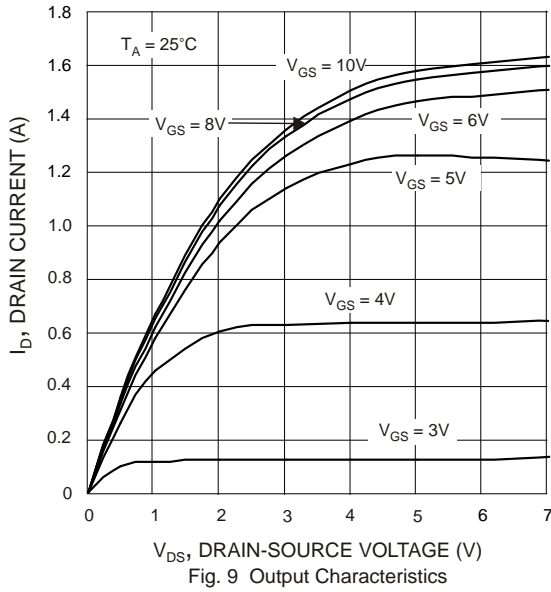

Fig. 8  $h_{FE}$  vs.  $I_C$



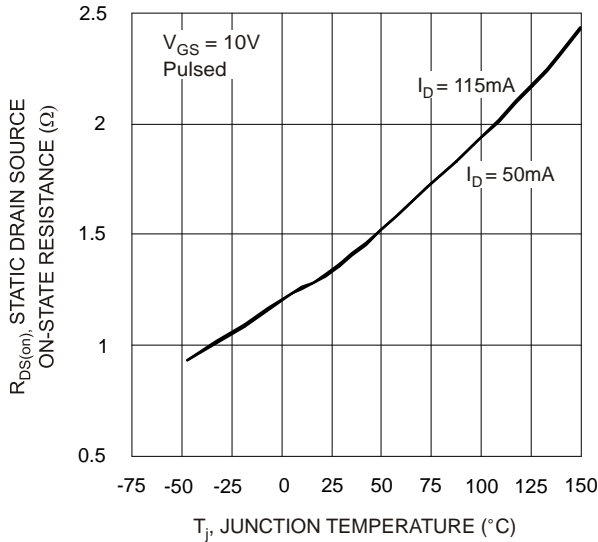

Fig. 15 Static Drain-Source On-State Resistance vs. Junction Temperature

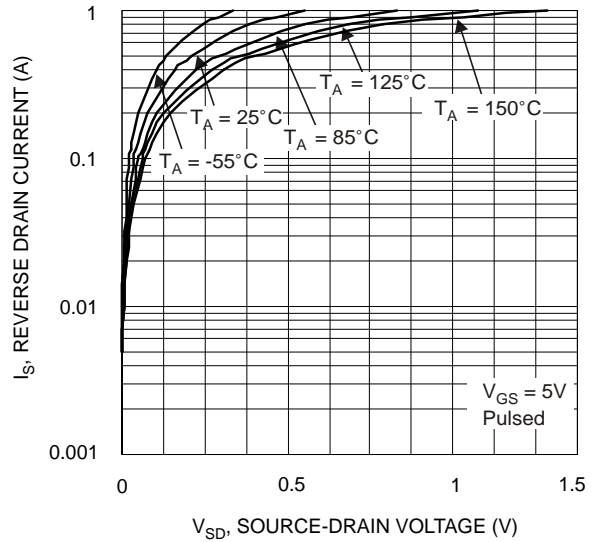

Fig. 16 Reverse Drain Current vs. Source-Drain Voltage

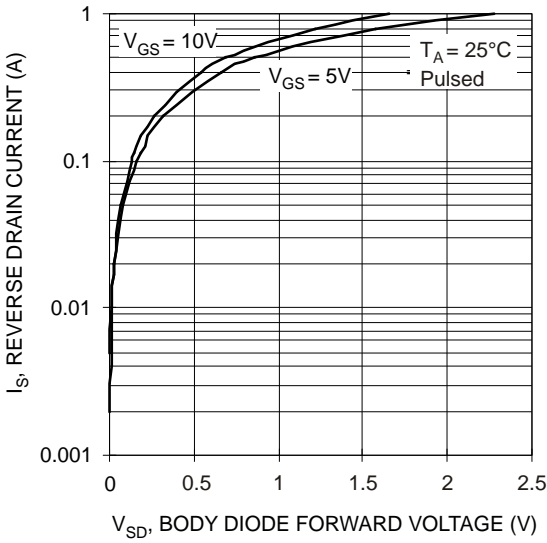

Fig. 17 Reverse Drain Current vs. Body Diode Forward Voltage

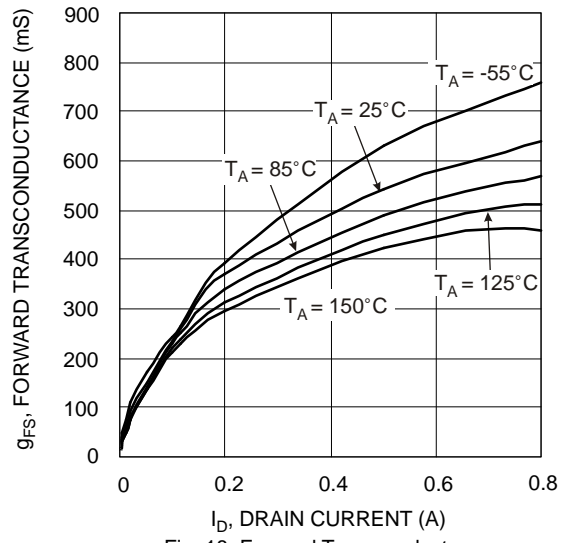

Fig. 18 Forward Transconductance vs. Drain Current ( $V_{DS} > I_D R_{DS(ON)}$ )

**Application Details**

- PNP Transistor (DDTB142JU) and N-MOSFET (DSNM6047) with gate pull-down resistor integrated as one in LMN200B01 can be used as a discrete entity for general purpose applications or as an integrated circuit to function as a Load Switch. When it is used as the latter as shown in Fig 19, various input voltage sources can be used as long as it does not exceed the maximum ratings of the device. These devices are designed to deliver continuous output load current up to a maximum of 200 mA. The MOSFET Switch draws no current, hence loading of control circuit is prevented. Care must be taken for higher levels of dissipation while designing for higher load conditions. These devices provide high power and also consume less space. The product mainly helps in optimizing power usage, thereby conserving battery life in a controlled load system like portable battery powered applications. (Please see Fig. 20 for one example of a typical application circuit used in conjunction with voltage regulator as a part of a power management system)

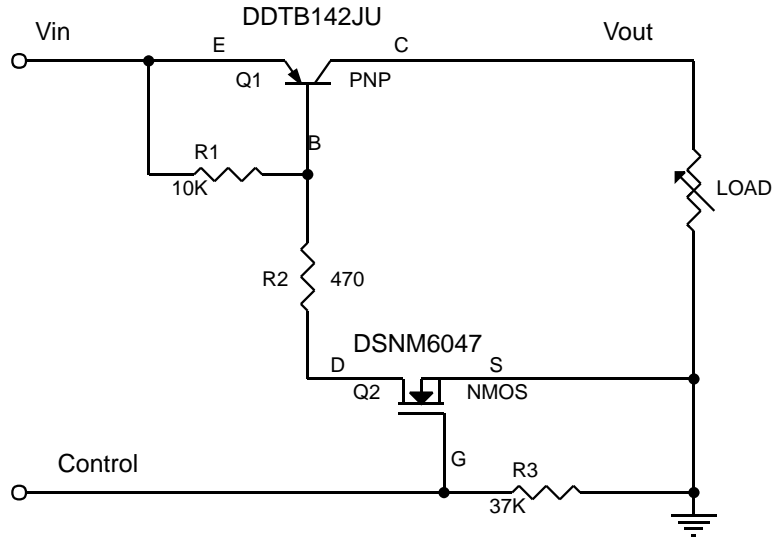

Fig. 19 Circuit Diagram

Typical Application Circuit

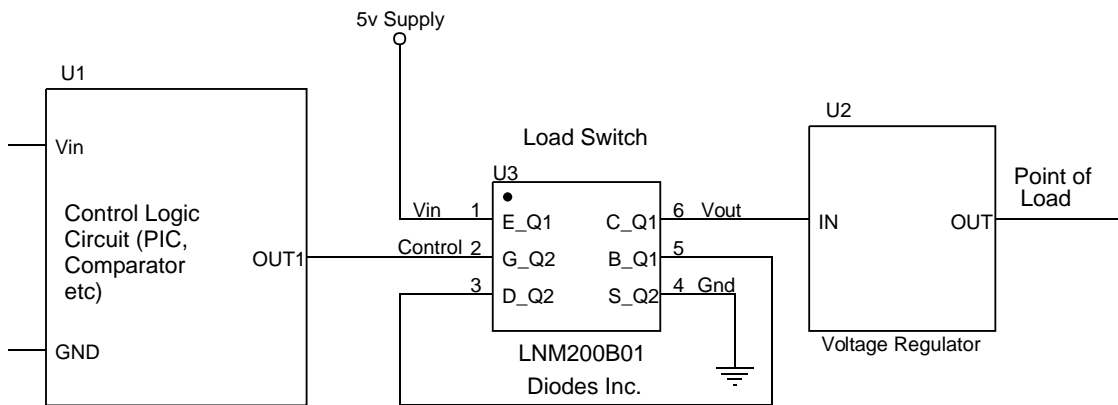

Fig. 20



**Ordering Information** (Note 5)

Device	Marking Code	Packaging	Shipping
LMN200B01-7	PM1	SOT-26	3000/Tape & Reel

Note: 5. For Packaging Details, go to our website at <http://www.diodes.com/datasheets/ap02007.pdf>.

**Marking Information**

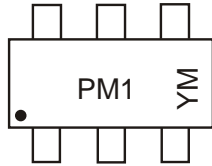

PM1 = Product Type Marking Code,  
 YM = Date Code Marking  
 Y = Year ex: T = 2006  
 M = Month ex: 9 = September

Fig. 21

Date Code Key

Year	2006	2007	2008	2009
Code	T	U	V	W

Month	Jan	Feb	March	Apr	May	Jun	Jul	Aug	Sep	Oct	Nov	Dec
Code	1	2	3	4	5	6	7	8	9	O	N	D

**Mechanical Details**

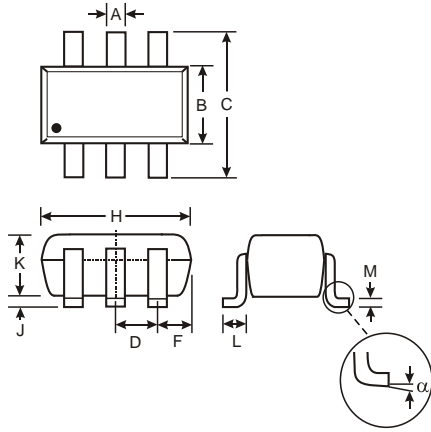

Fig. 22

SOT-26			
Dim	Min	Max	Typ
A	0.35	0.5	0.38
B	1.5	1.7	1.6
C	2.7	3	2.8
D	-	-	0.95
F	-	-	0.55
H	2.9	3.1	3
J	0.013	0.1	0.05
K	1	1.3	1.1
L	0.35	0.55	0.4
M	0.1	0.2	0.15
	0°	8°	-
All Dimensions in mm			

**Suggested Pad Layout: (Based on IPC-SM-782)**

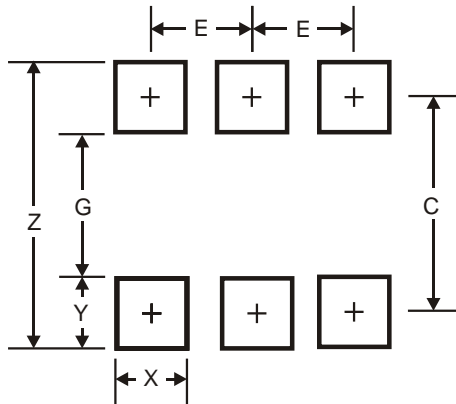

Fig. 23

Figure 23 Dimensions	SOT-26*
Z	3.2
G	1.6
X	0.55
Y	0.8
C	2.4
E	0.95

**IMPORTANT NOTICE**

Diodes, Inc. and its subsidiaries reserve the right to make changes without further notice to any product herein to make corrections, modifications, enhancements, improvements, or other changes. Diodes, Inc. does not assume any liability arising out of the application or use of any product described herein; neither does it convey any license under its patent rights, nor the rights of others. The user of products in such applications shall assume all risks of such use and will agree to hold Diodes Incorporated and all the companies whose products are represented on our website, harmless against all damages.

**LIFE SUPPORT**

The products located on our website at [www.diodes.com](http://www.diodes.com) are not recommended for use in life support systems where a failure or malfunction of the component may directly threaten life or cause injury without the expressed written approval of Diodes Incorporated.



Компания «ЭлектроПласт» предлагает заключение долгосрочных отношений при поставках импортных электронных компонентов на взаимовыгодных условиях!

Наши преимущества:

- Оперативные поставки широкого спектра электронных компонентов отечественного и импортного производства напрямую от производителей и с крупнейших мировых складов;
- Поставка более 17-ти миллионов наименований электронных компонентов;
- Поставка сложных, дефицитных, либо снятых с производства позиций;
- Оперативные сроки поставки под заказ (от 5 рабочих дней);
- Экспресс доставка в любую точку России;
- Техническая поддержка проекта, помощь в подборе аналогов, поставка прототипов;
- Система менеджмента качества сертифицирована по Международному стандарту ISO 9001;
- Лицензия ФСБ на осуществление работ с использованием сведений, составляющих государственную тайну;
- Поставка специализированных компонентов (Xilinx, Altera, Analog Devices, Intersil, Interpoint, Microsemi, Aeroflex, Peregrine, Syfer, Eurofarad, Texas Instrument, Miteq, Cobham, E2V, MA-COM, Hittite, Mini-Circuits, General Dynamics и др.);

Помимо этого, одним из направлений компании «ЭлектроПласт» является направление «Источники питания». Мы предлагаем Вам помощь Конструкторского отдела:

- Подбор оптимального решения, техническое обоснование при выборе компонента;
- Подбор аналогов;
- Консультации по применению компонента;
- Поставка образцов и прототипов;
- Техническая поддержка проекта;
- Защита от снятия компонента с производства.



#### Как с нами связаться

**Телефон:** 8 (812) 309 58 32 (многоканальный)

**Факс:** 8 (812) 320-02-42

**Электронная почта:** [org@eplast1.ru](mailto:org@eplast1.ru)

**Адрес:** 198099, г. Санкт-Петербург, ул. Калинина, дом 2, корпус 4, литера А.