

UFX6000

USB 2.0 Hi-Speed Graphics Controller with VGA, HDMI/DVI, and Digital RGB Interfaces



PRODUCT FEATURES

Data Brief

Highlights

- Single-Chip Hi-Speed USB 2.0 Graphics Adapter
- USB 2.0 Device Controller with Integrated USB 2.0 PHY
- High Efficiency USB Graphics Adapter
- HDMI/DVI Display Connectivity via Integrated HDMI/DVI Controller/PHY
- VGA Display Connectivity via Integrated Video DAC
- Support for External Display Interface IC's via Digital RGB Interface
- High Performance DDR2 SDRAM Controller with Integrated DDR2 PHY

Target Applications

- USB to Video Adapters
- Docking Stations, USB Port Replicators
- Thin Clients
- USB Monitors and Projectors
- Embedded Systems

Features

- USB 2.0 Device Controller
 - Fully compliant with Universal Serial Bus Specification Revision 2.0
 - Operates in HS (480 Mbps) mode
 - Supports Control, Bulk-Out, and Interrupt-In endpoints
 - Supports vendor specific commands
 - Integrated USB 2.0 PHY
 - Integrated USB termination pull-up/pull-down resistors
 - Short circuit protection of USB differential signals

- Graphics Subsystem
 - Integrated HDMI/DVI Controller and PHY
 - Complies with DVI specification v1.0
 - Complies with HDMI specification v1.3
 - S/PDIF and I²S inputs for HDMI audio (2-channel uncompressed PCM)
 - Master I²C interface for DDC connection
 - Integrated Triple 10-bit Video DAC with VGA output
 - Digital RGB Interface
 - 12/15-bit double data rate digital RGB
 - 24-bit single data rate digital RGB
 - Supports up to 2048x1152 (QWXGA) with 32-bit color
 - 8-bit and 16-bit color support
 - Supports display cloning and extending
 - Standard and wide screen aspect ratios
 - Complies with VESA auto display identification
 - Gamma correction
 - Color Look-Up Table (CLUT)
 - Triple-buffered animations
 - Graphics Engine
 - Optimized algorithms for static and dynamic content
 - I²C controller
- DDR2 SDRAM Controller
 - 16-bit data bus, 13-bit address bus
 - JEDEC DDR2 compliant (JESD79-2E)
 - Integrated DDR2 SDRAM PHY
- Power
 - Reduced power operating modes
 - Supports bus-powered and self-powered operation
- Miscellaneous Features
 - Optional EEPROM controller
 - IEEE 1149.1 (JTAG) boundary scan TAP controller
- Software
 - Microsoft Windows® XP/Vista/7 drivers
- Packaging & Environmental
 - 225-ball LFBGA, lead-free RoHS compliant package
 - Commercial temperature range (0°C to +70°C)

Order Number:

UFX6000-VE for 225-Ball LFBGA lead-free RoHS compliant package (0 to +70°C temp range)

This product meets the halogen maximum concentration values per IEC61249-2-21

For RoHS compliance and environmental information, please visit www.smSC.com/rohs

Copyright © 2012 SMSC or its subsidiaries. All rights reserved.

Circuit diagrams and other information relating to SMSC products are included as a means of illustrating typical applications. Consequently, complete information sufficient for construction purposes is not necessarily given. Although the information has been checked and is believed to be accurate, no responsibility is assumed for inaccuracies. SMSC reserves the right to make changes to specifications and product descriptions at any time without notice. Contact your local SMSC sales office to obtain the latest specifications before placing your product order. The provision of this information does not convey to the purchaser of the described semiconductor devices any licenses under any patent rights or other intellectual property rights of SMSC or others. All sales are expressly conditional on your agreement to the terms and conditions of the most recently dated version of SMSC's standard Terms of Sale Agreement dated before the date of your order (the "Terms of Sale Agreement"). The product may contain design defects or errors known as anomalies which may cause the product's functions to deviate from published specifications. Anomaly sheets are available upon request. SMSC products are not designed, intended, authorized or warranted for use in any life support or other application where product failure could cause or contribute to personal injury or severe property damage. Any and all such uses without prior written approval of an Officer of SMSC and further testing and/or modification will be fully at the risk of the customer. Copies of this document or other SMSC literature, as well as the Terms of Sale Agreement, may be obtained by visiting SMSC's website at <http://www.smSC.com>. SMSC is a registered trademark of Standard Microsystems Corporation ("SMSC"). Product names and company names are the trademarks of their respective holders.

The Microchip name and logo, and the Microchip logo are registered trademarks of Microchip Technology Incorporated in the U.S.A. and other countries.

SMSC DISCLAIMS AND EXCLUDES ANY AND ALL WARRANTIES, INCLUDING WITHOUT LIMITATION ANY AND ALL IMPLIED WARRANTIES OF MERCHANTABILITY, FITNESS FOR A PARTICULAR PURPOSE, TITLE, AND AGAINST INFRINGEMENT AND THE LIKE, AND ANY AND ALL WARRANTIES ARISING FROM ANY COURSE OF DEALING OR USAGE OF TRADE. IN NO EVENT SHALL SMSC BE LIABLE FOR ANY DIRECT, INCIDENTAL, INDIRECT, SPECIAL, PUNITIVE, OR CONSEQUENTIAL DAMAGES; OR FOR LOST DATA, PROFITS, SAVINGS OR REVENUES OF ANY KIND; REGARDLESS OF THE FORM OF ACTION, WHETHER BASED ON CONTRACT; TORT; NEGLIGENCE OF SMSC OR OTHERS; STRICT LIABILITY; BREACH OF WARRANTY; OR OTHERWISE; WHETHER OR NOT ANY REMEDY OF BUYER IS HELD TO HAVE FAILED OF ITS ESSENTIAL PURPOSE, AND WHETHER OR NOT SMSC HAS BEEN ADVISED OF THE POSSIBILITY OF SUCH DAMAGES.

General Description

The UFX6000 is a high performance USB 2.0 graphics adapter with multiple graphics interfaces. The UFX6000 is an ideal solution for extending a PC workspace to an additional monitor without the need for an additional internal graphics card. With applications ranging from docking stations, USB port replicators, USB monitors/projectors, and embedded systems, the UFX6000 is targeted as a high performance, low cost USB-to-graphics solution.

The UFX6000 contains an integrated USB 2.0 Device Controller, USB 2.0 PHY, USB Bulk-Out Controller, Control Endpoint, Interrupt-In Endpoint, DDR2 SDRAM Controller/PHY, Graphics Engine, HDMI/DVI Controller/PHY, Video DAC, TAP Controller, EEPROM Controller, and I²C Controller. Figure 1 details an internal block diagram of the UFX6000.

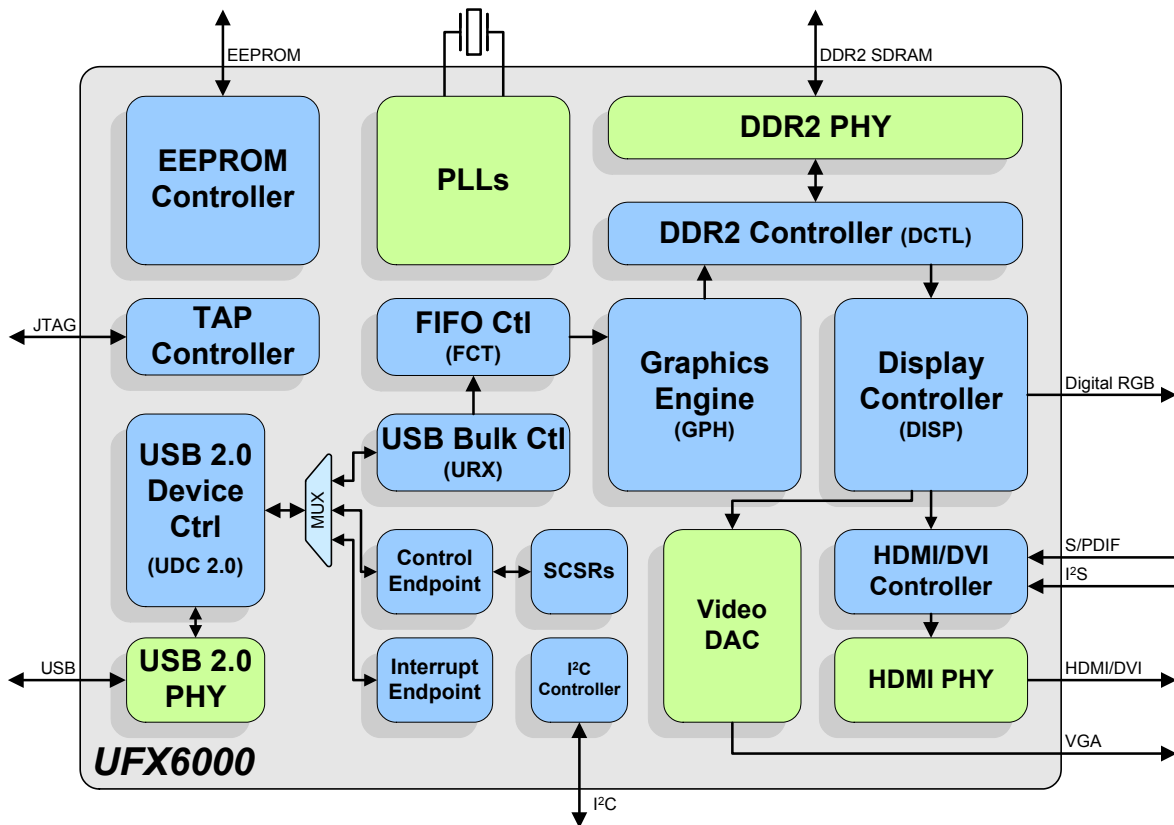

Figure 1 Internal Block Diagram

USB DEVICE CONTROLLER

The USB Device Controller is fully compliant with the USB 2.0 Specification, enabling the device to operate in Hi-Speed (480 Mbps) mode. An integrated USB 2.0 PHY is provided on the USB port.

The controller implements three USB endpoints: Control, Bulk-Out, and Interrupt-In. The Bulk-Out endpoint allows for uncompressed or compressed graphics data reception from the USB port. The USB Bulk-Out Controller collects the graphics information and transfers it to the Graphics Engine. Implementation of vendor-specific commands allows for access to the device System Control and Status Registers (SCSRs).

USB GRAPHICS ADAPTER

The USB Graphics Adapter consists of the following main blocks: the Graphics Engine, Display Controller, HDMI/DVI Controller/PHY, Video DAC, and the Digital RGB Interface. Together, these blocks support high definition resolutions of up to 2048x1152 (QWXGA) with 32-bit true color in both standard and wide screen aspect ratios. The HDMI/DVI interface is compliant with the HDMI v1.3 and DVI v1.0 specifications and supports 2-channel uncompressed PCM audio via a S/PDIF or I²S input. The Display Controller also supports 8-bit and 16-bit color, gamma correction, Color Look-Up Table (CLUT) and triple-buffered animation. The DDC2B/EDID VESA standard is supported, allowing the host OS and device drivers to query the monitor's frequency, resolution, and other features for true plug-and-play and intelligent mode setting capabilities.

Once the graphics data has been received via the USB Bulk-Out Controller, it is sent to the Graphics Engine. If the data is compressed, the Graphics Engine decompresses it via algorithms that have been optimized for speed and quality. The device's decompression algorithms have been designed to work seamlessly with the compression algorithms utilized in the software device drivers.

The graphics data is then transferred to the SDRAM via the DDR2 SDRAM Controller. The Display Controller generates all display and interface timing signals, retrieves the graphics data from the DDR2 SDRAM, and sends it to the HDMI/DVI Controller/PHY, Video DAC, or Digital RGB Interface.

The Digital RGB Interface may be used to connect external display interface IC's (e.g., DisplayPort, etc.) via the provided RGB data channel busses and control signals. The Digital RGB Interface supports two modes of operation: 24-bit single data rate mode and 12/15-bit double data rate mode. 24-bit mode is single edge triggered and utilizes the full 24-bit data bus width. The 12/15-bit mode is triggered on both clock edges and utilizes 12/15-bits of the data bus width.

DDR2 SDRAM INTERFACE

The UFX6000 provides a full JEDEC compliant (JESD79-2E) DDR2 SDRAM Controller and PHY for interfacing to external DDR2 SDRAM. The DDR2 SDRAM interface is comprised of JEDEC standard 1.8V I/O signals grouped into control signals, a 16-bit data bus, and a 13-bit address bus.

The DDR2 SDRAM Controller transfers the graphics data in and out of external SDRAM through the DDR2 SDRAM PHY. External SDRAM is used as storage for the graphics and acts as a buffer between the Graphics Engine and Display Controller.

PERIPHERALS

The UFX6000 also contains an EEPROM Controller, I²C Controller, and TAP Controller.

The EEPROM Controller allows connection to an external EEPROM for automatic loading of static configuration data upon power-on, pin reset, or software reset. The EEPROM can be configured to load USB descriptors and USB device configuration.

The integrated IEEE 1149.1 compliant TAP controller provides boundary scan via JTAG.

Package Outline

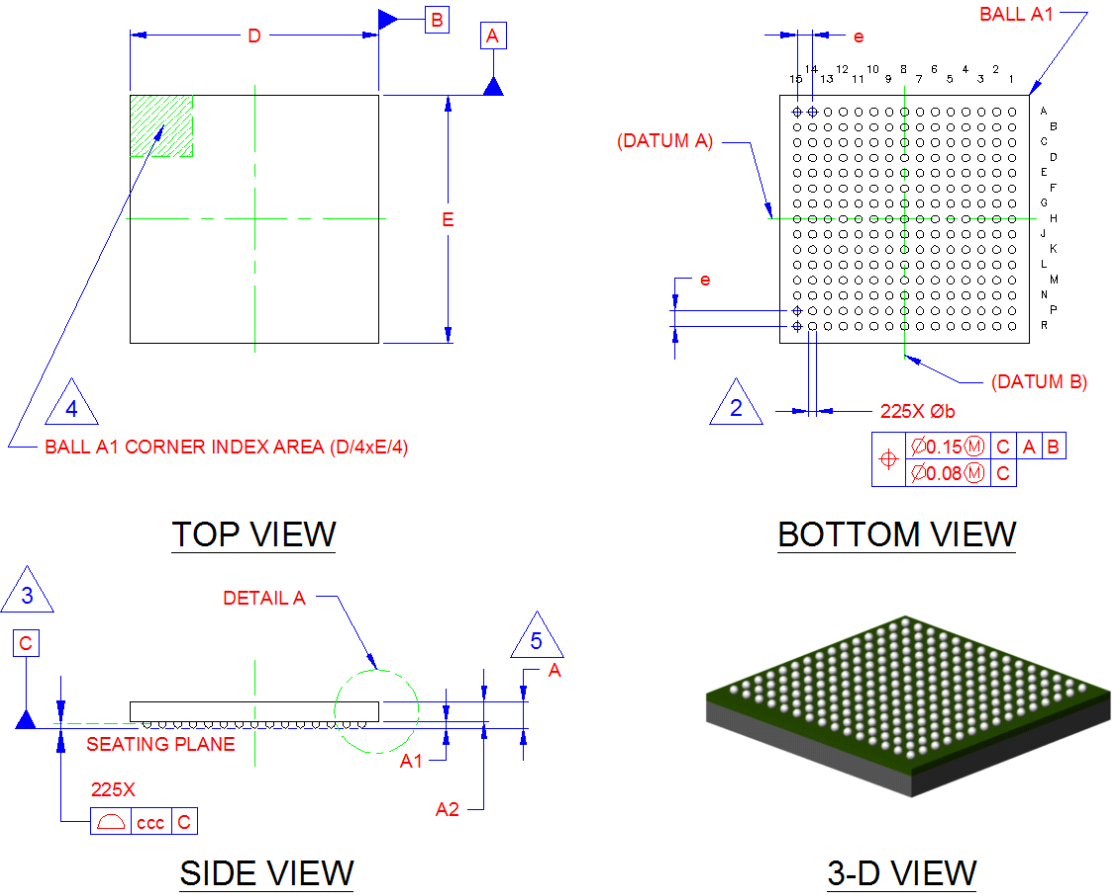

Figure 2 225-Ball LFBGA Package

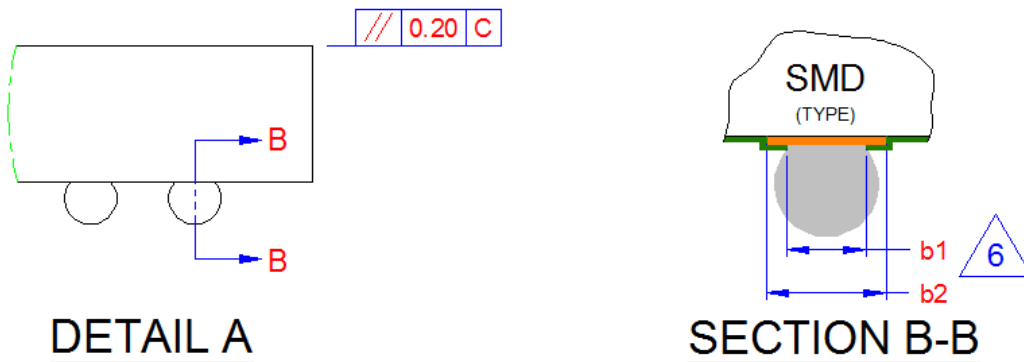

Figure 3 225-Ball LFBGA Package Ball Detail

Table 1 225-LFBGA Package Parameters

	MIN	NOMINAL	MAX	REMARKS
A	-	1.30	1.40	Overall Package Height
A1	0.25	-	0.40	Standoff
A2	0.65	0.96	-	Package Body Thickness
D/E	12.90	13.00	13.10	Overall Package Size
b	0.40	0.45	0.50	Ball Diameter
b1	0.35	0.40	0.45	Finished Solder Mask Opening
b2	0.45	0.50	0.55	Finished Ball Pad Diameter
e	0.80 BSC			Ball Pitch
ccc	-	-	0.20	Coplanarity

Notes:

1. All dimensions are in millimeters.
2. Dimension "b" is measured at the maximum ball diameter, parallel to primary datum "C".
3. Primary datum "C" (seating plane) is defined by the spherical crowns of the contact balls.
4. The ball A1 identifier may vary, but is always located within the zone indicated.
5. Dimension "A" does not include attached external features, such as heat sink or chip capacitors.
6. The package ball solderable surface is Solder-Mask-Defined (SMD) type.

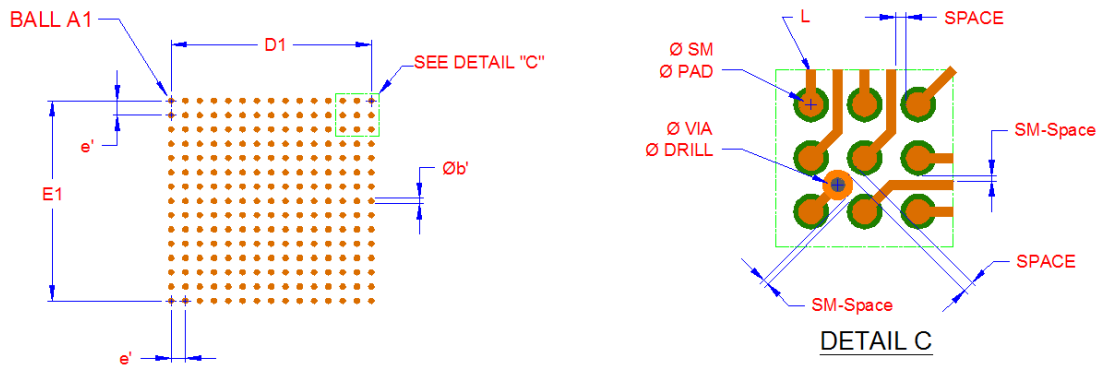

PCB LAND PATTERN DIMENSIONS			
SYMBOL	MIN	NOM	MAX
D1/E1	-	11.20	-
e'	0.80 BSC		

THE USER MAY MODIFY THE PCB LAND PATTERN & ROUTING DIMENSIONS, BASED ON THEIR EXPERIENCE AND/OR PROCESS CAPABILITY

ROUTING DIMENSIONS	
SYMBOL	NOM
Ø PAD	0.40
Ø SM	0.50
L (Trace)	0.125
SPACE	0.135
SM-Space	0.09
Ø VIA PAD	0.45
Ø DRILL	0.25

PCB LAND PATTERN

Figure 4 225-LFGBA Recommended PCB Land Pattern

Mouser Electronics

Authorized Distributor

Click to View Pricing, Inventory, Delivery & Lifecycle Information:

[Microchip:](#)

[UFX6000-VE](#) [UFX6000-VE-TR](#)



Компания «ЭлектроПласт» предлагает заключение долгосрочных отношений при поставках импортных электронных компонентов на взаимовыгодных условиях!

Наши преимущества:

- Оперативные поставки широкого спектра электронных компонентов отечественного и импортного производства напрямую от производителей и с крупнейших мировых складов;
- Поставка более 17-ти миллионов наименований электронных компонентов;
- Поставка сложных, дефицитных, либо снятых с производства позиций;
- Оперативные сроки поставки под заказ (от 5 рабочих дней);
- Экспресс доставка в любую точку России;
- Техническая поддержка проекта, помощь в подборе аналогов, поставка прототипов;
- Система менеджмента качества сертифицирована по Международному стандарту ISO 9001;
- Лицензия ФСБ на осуществление работ с использованием сведений, составляющих государственную тайну;
- Поставка специализированных компонентов (Xilinx, Altera, Analog Devices, Intersil, Interpoint, Microsemi, Aeroflex, Peregrine, Syfer, Eurofarad, Texas Instrument, Miteq, Cobham, E2V, MA-COM, Hittite, Mini-Circuits, General Dynamics и др.);

Помимо этого, одним из направлений компании «ЭлектроПласт» является направление «Источники питания». Мы предлагаем Вам помощь Конструкторского отдела:

- Подбор оптимального решения, техническое обоснование при выборе компонента;
- Подбор аналогов;
- Консультации по применению компонента;
- Поставка образцов и прототипов;
- Техническая поддержка проекта;
- Защита от снятия компонента с производства.



Как с нами связаться

Телефон: 8 (812) 309 58 32 (многоканальный)

Факс: 8 (812) 320-02-42

Электронная почта: org@eplast1.ru

Адрес: 198099, г. Санкт-Петербург, ул. Калинина, дом 2, корпус 4, литера А.