

60 W motor control power board based on STIPNS1M50T-H SLLIMM™-nano SMD IPM MOSFET

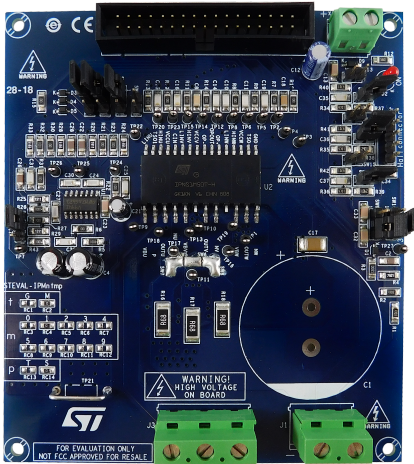

Features

- Input voltage: from 125 to 400 V_{DC}
- Nominal power: up to 60 W
- Nominal current: up to 0.6 A
- Input auxiliary voltage: up to 20 V_{DC}
- Single- or three-shunt resistors for current sensing (with sensing network)
- Three options for current sensing: dedicated external op-amps, internal SLLIMM-nano SMD op-amp (single) or via MCU
- Overcurrent hardware protection
- IPM temperature monitoring and protection
- Hall sensor or encoder input
- MOSFETs intelligent power module:
 - SLLIMM-nano IPM (STIPNS1M50T-H) - SMD package
- Motor control connector (32 pins) interfacing with ST MCU boards
- Universal design for further evaluation with breadboard and testing pins
- Very compact size
- WEEE compliant
- RoHS compliant

Description

The **STEVAL-IPMnM1S** is a compact motor drive power board based on SLLIMM-nano SMD (small low-loss intelligent molded module) product (**STIPNS1M50T-H**). It provides an affordable and easy-to-use solution for driving high power motors in a wide range of applications such as power white goods, air conditioning, compressors, power fans and 3-phase inverters for motor drives in general.

The IPM itself consists of six MOSFETs, three high voltage half-bridge gate driver ICs and a wide range of features like undervoltage lockout, smart shutdown, internal temperature sensor and NTC, overcurrent protection and internal op-amp.

The main characteristics of this evaluation board are small size, minimal BOM and high efficiency. It features an interface circuit (BUS and VCC connectors), bootstrap capacitors, snubber capacitor, hardware short-circuit protection, fault event signal and temperature monitoring. It is designed to work in single- or three-shunt configuration and with triple current sensing options: three dedicated on-board op-amps, op-amps embedded on MCU or single internal IPM op-amp. The Hall/Encoder part completes the circuit.

The system is designed to achieve accurate and fast conditioning of current feedback to satisfy the typical requirements for field oriented control (FOC).

The STEVAL-IPMnM1S is compatible with ST's control board based on STM32, providing a complete platform for motor control.

Product summary	
Motor control power board based on the SLLIMM-nano in SMD package	STEVAL-IPMnM1S
SLLIMM-nano SMD small low-loss intelligent molded module IPM, 3-phase inverter, 1 A, 3.6 Ohm max., 500 V MOSFET	STIPNS1M50T-H

1 Schematic diagrams

Figure 2. STEVAL-IPMnM1S - circuit schematic (1 of 5)

Figure 3. STEVAL-IPMnM1S - circuit schematic (2 of 5)

Figure 4. STEVAL-IPMnM1S - circuit schematic (3 of 5)

Figure 5. STEVAL-IPMnM1S - circuit schematic (4 of 5)

Figure 6. STEVAL-IPMnM1S - circuit schematic (5 of 5)

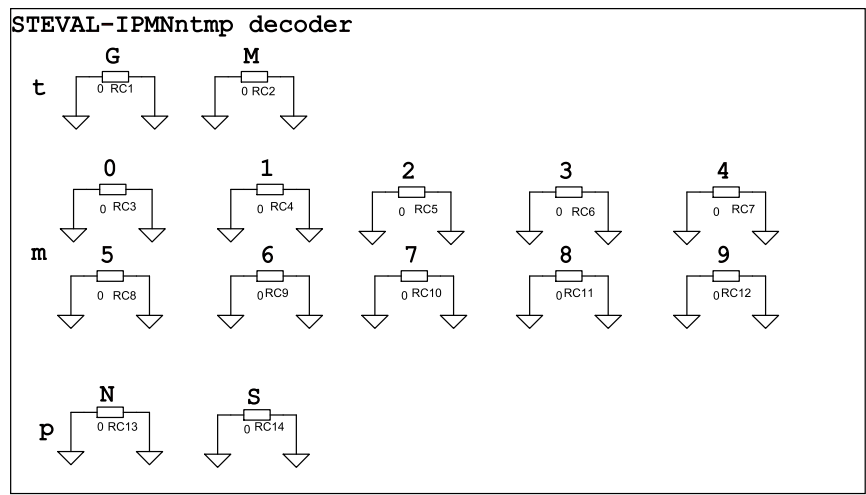
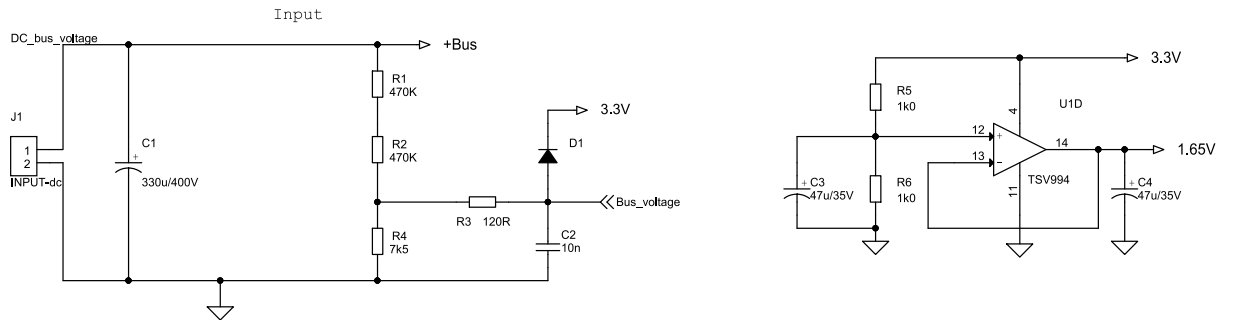
Revision history

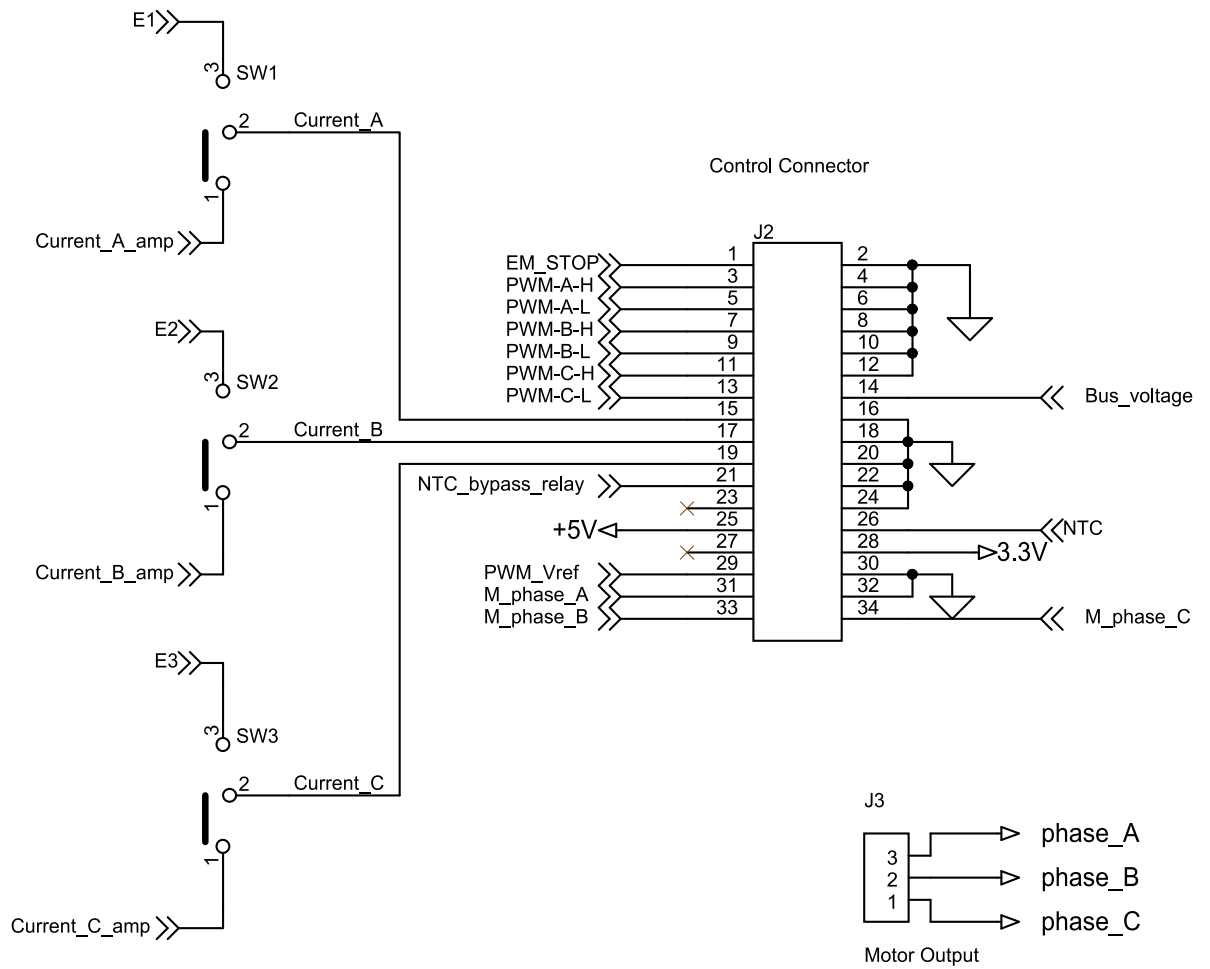
Table 1. Document revision history

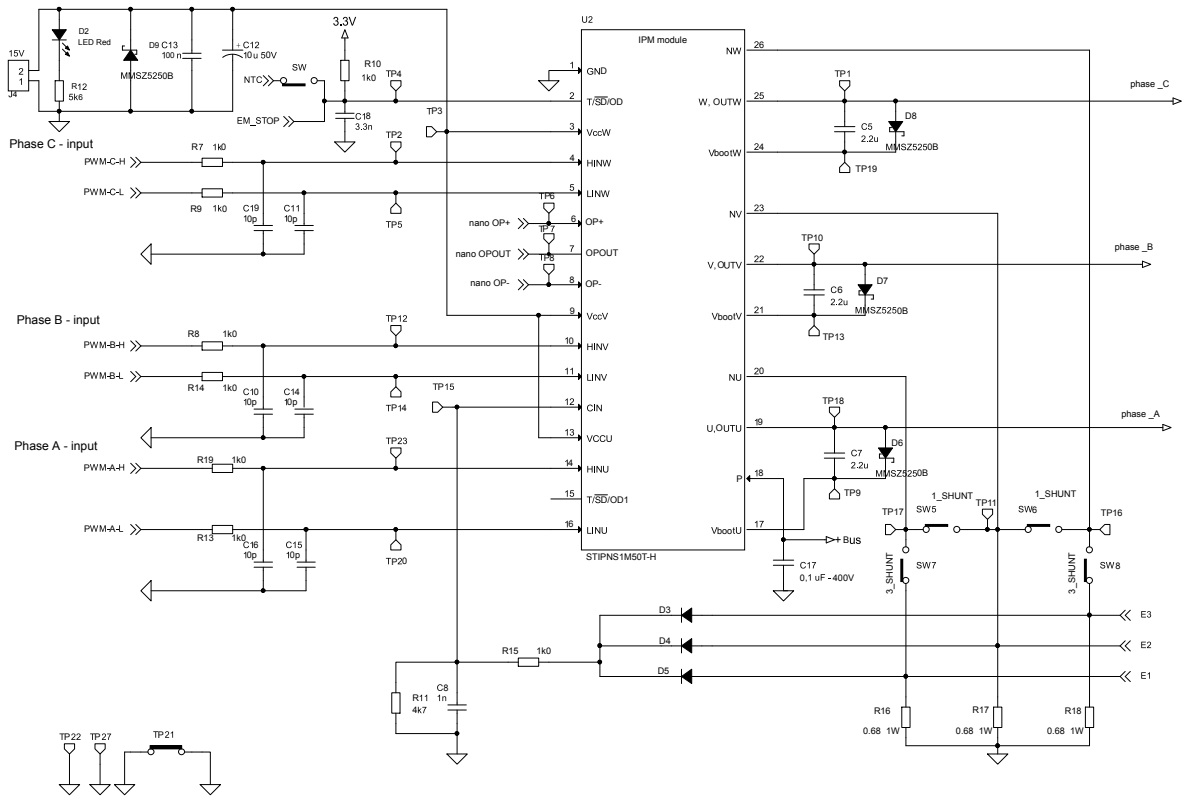
Date	Version	Changes
10-Aug-2018	1	Initial release.
21-Sep-2018	2	Update Section features and Section 1 schematic

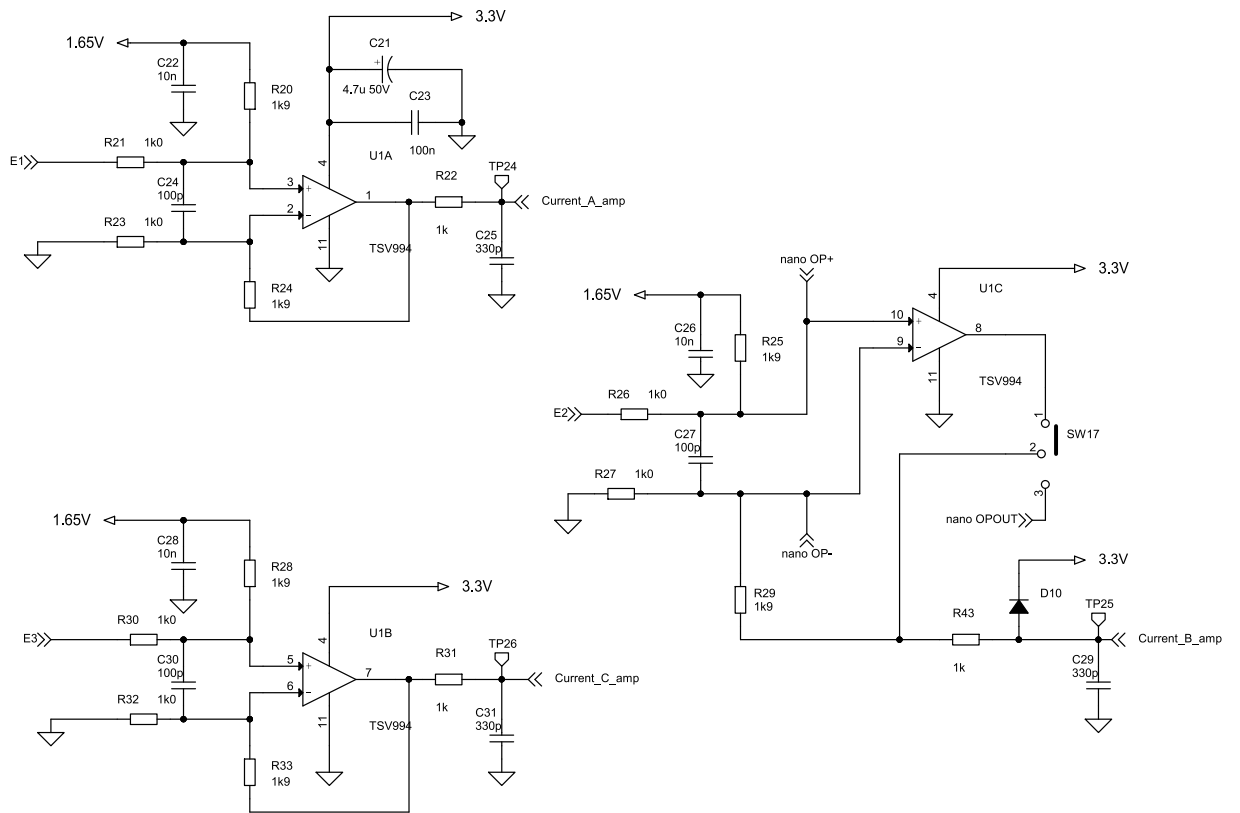
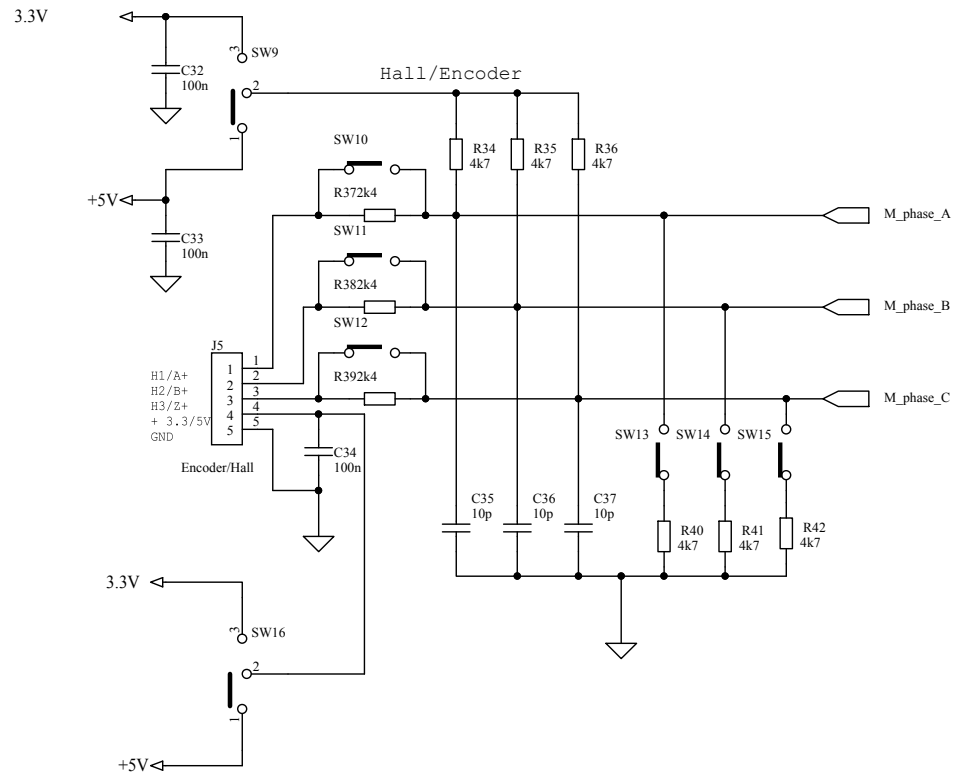
IMPORTANT NOTICE – PLEASE READ CAREFULLY

STMicroelectronics NV and its subsidiaries (“ST”) reserve the right to make changes, corrections, enhancements, modifications, and improvements to ST products and/or to this document at any time without notice. Purchasers should obtain the latest relevant information on ST products before placing orders. ST products are sold pursuant to ST’s terms and conditions of sale in place at the time of order acknowledgement.

Purchasers are solely responsible for the choice, selection, and use of ST products and ST assumes no liability for application assistance or the design of Purchasers’ products.

No license, express or implied, to any intellectual property right is granted by ST herein.

Resale of ST products with provisions different from the information set forth herein shall void any warranty granted by ST for such product.

ST and the ST logo are trademarks of ST. All other product or service names are the property of their respective owners.

Information in this document supersedes and replaces information previously supplied in any prior versions of this document.

© 2018 STMicroelectronics – All rights reserved



Компания «ЭлектроПласт» предлагает заключение долгосрочных отношений при поставках импортных электронных компонентов на взаимовыгодных условиях!

Наши преимущества:

- Оперативные поставки широкого спектра электронных компонентов отечественного и импортного производства напрямую от производителей и с крупнейших мировых складов;
- Поставка более 17-ти миллионов наименований электронных компонентов;
- Поставка сложных, дефицитных, либо снятых с производства позиций;
- Оперативные сроки поставки под заказ (от 5 рабочих дней);
- Экспресс доставка в любую точку России;
- Техническая поддержка проекта, помощь в подборе аналогов, поставка прототипов;
- Система менеджмента качества сертифицирована по Международному стандарту ISO 9001;
- Лицензия ФСБ на осуществление работ с использованием сведений, составляющих государственную тайну;
- Поставка специализированных компонентов (Xilinx, Altera, Analog Devices, Intersil, Interpoint, Microsemi, Aeroflex, Peregrine, Syfer, Eurofarad, Texas Instrument, Miteq, Cobham, E2V, MA-COM, Hittite, Mini-Circuits, General Dynamics и др.);

Помимо этого, одним из направлений компании «ЭлектроПласт» является направление «Источники питания». Мы предлагаем Вам помощь Конструкторского отдела:

- Подбор оптимального решения, техническое обоснование при выборе компонента;
- Подбор аналогов;
- Консультации по применению компонента;
- Поставка образцов и прототипов;
- Техническая поддержка проекта;
- Защита от снятия компонента с производства.



Как с нами связаться

Телефон: 8 (812) 309 58 32 (многоканальный)

Факс: 8 (812) 320-02-42

Электронная почта: org@eplast1.ru

Адрес: 198099, г. Санкт-Петербург, ул. Калинина, дом 2, корпус 4, литера А.