

SMT Power Transformer

For Linear Technology
LT1725 Flyback Controller

The A9967-AL surface mount transformer works with with Linear Technology LT1725 Isolated Flyback Controller. It is ideal for use in telecommunications isolated converters and isolated power supplies, and can be used in PoE applications.

This low-profile transformer is designed for an input voltage of 36 – 72 Volts. It features six 1-to-1 windings and 500 Vrms, one minute isolation between windings.

For the LT1725, 48 V to 15 V converter, three windings are connected in series for the primary and two windings are connected in parallel for the secondary output of 15 V, 2 A. The remaining winding provides power to the chipset.

Coilcraft can also custom engineer a transformer to meet your specific requirements. For free evaluation samples, contact Coilcraft or visit www.coilcraft.com.

Part number ¹	Inductance at 0A ² ±10% (µH)	Inductance at Ipk ³ min (µH)	DCR max ⁴ (Ohms)	Leakage inductance ⁵ max (µH)	Ipk ³ (A)	Output ⁶
A9967-AL_	10.0	9.0	0.045	0.200	2.3	15 V, 2 A

1. When ordering, please specify **packaging** code:

A9967-ALD

Packaging: **D** = 13" machine-ready reel. EIA-481 embossed plastic tape (175 parts per full reel).

B = Less than full reel. In tape, but not machine ready. To have a leader and trailer added (\$25 charge), use code letter D instead.

2. Inductance is per winding of the primary, measured at 100 kHz, 0.1 Vrms, 0 Adc. Inductance of the primary, with three windings connected in series is 90 µH.

3. Peak primary current (with three windings connected in series) drawn at minimum input voltage. Peak current per winding is 7.0 A.

4. DCR is per winding.

5. Leakage inductance is for one winding and is measured with all other windings shorted.

6. Output is with both windings of the secondary connected in parallel.

7. Electrical specifications at 25°C.

Refer to Doc 362 "Soldering Surface Mount Components" before soldering.

Core material Ferrite

Weight: 11.9 g

Terminations RoHS tin-silver over tin over nickel over phos bronze. Other terminations available at additional cost.

Ambient temperature –40°C to +125°C

Storage temperature Component: –40°C to +125°C.

Tape and reel packaging: –40°C to +80°C

Resistance to soldering heat Max three 40 second reflows at +260°C, parts cooled to room temperature between cycles

Moisture Sensitivity Level (MSL) 1 (unlimited floor life at <30°C / 85% relative humidity)

Failures in Time (FIT) / Mean Time Between Failures (MTBF)

38 per billion hours / 26,315,789 hours, calculated per Telcordia SR-332

Packaging 175 per 13" reel Plastic tape: 44 mm wide, 0.4 mm thick, 28 mm pocket spacing, 12.0 mm pocket depth

PCB washing Tested with pure water or alcohol only. For other solvents, see Doc787_PCB_Washing.pdf.

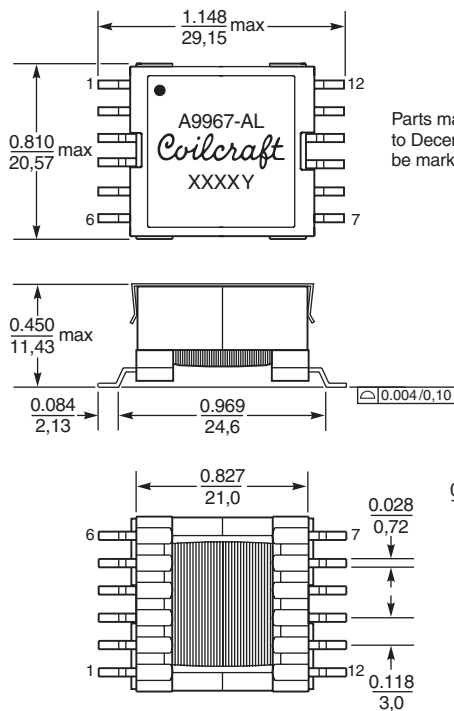

Dimensions are in inches
mm

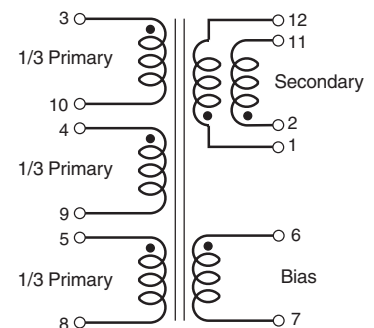

Primary windings to be connected in series on the PC board. Secondary winding to be connected in parallel on the PC board.

Coilcraft
www.coilcraft.com

US +1-847-639-6400 sales@coilcraft.com
UK +44-1236-730595 sales@coilcraft-europe.com
Taiwan +886-2-2264 3646 sales@coilcraft.com.tw
China +86-21-6218 8074 sales@coilcraft.com.cn
Singapore + 65-6484 8412 sales@coilcraft.com.sg

Document 376 Revised 08/06/13

© Coilcraft Inc. 2013

This product may not be used in medical or high risk applications without prior Coilcraft approval. Specification subject to change without notice. Please check web site for latest information.



Компания «ЭлектроПласт» предлагает заключение долгосрочных отношений при поставках импортных электронных компонентов на взаимовыгодных условиях!

Наши преимущества:

- Оперативные поставки широкого спектра электронных компонентов отечественного и импортного производства напрямую от производителей и с крупнейших мировых складов;
- Поставка более 17-ти миллионов наименований электронных компонентов;
- Поставка сложных, дефицитных, либо снятых с производства позиций;
- Оперативные сроки поставки под заказ (от 5 рабочих дней);
- Экспресс доставка в любую точку России;
- Техническая поддержка проекта, помощь в подборе аналогов, поставка прототипов;
- Система менеджмента качества сертифицирована по Международному стандарту ISO 9001;
- Лицензия ФСБ на осуществление работ с использованием сведений, составляющих государственную тайну;
- Поставка специализированных компонентов (Xilinx, Altera, Analog Devices, Intersil, Interpoint, Microsemi, Aeroflex, Peregrine, Syfer, Eurofarad, Texas Instrument, Miteq, Cobham, E2V, MA-COM, Hittite, Mini-Circuits, General Dynamics и др.);

Помимо этого, одним из направлений компании «ЭлектроПласт» является направление «Источники питания». Мы предлагаем Вам помощь Конструкторского отдела:

- Подбор оптимального решения, техническое обоснование при выборе компонента;
- Подбор аналогов;
- Консультации по применению компонента;
- Поставка образцов и прототипов;
- Техническая поддержка проекта;
- Защита от снятия компонента с производства.



Как с нами связаться

Телефон: 8 (812) 309 58 32 (многоканальный)

Факс: 8 (812) 320-02-42

Электронная почта: org@eplast1.ru

Адрес: 198099, г. Санкт-Петербург, ул. Калинина, дом 2, корпус 4, литера А.