

Automotive 5 V low drop voltage regulator

Datasheet - production data

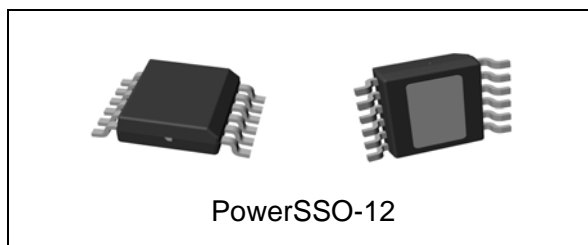

- Programmable reset pulse delay with external capacitor
- Early warning
- Very wide stability range with low value output capacitor
- Thermal shutdown and short circuit protection
- Wide temperature range ($T_j = -40\text{ }^\circ\text{C}$ to $150\text{ }^\circ\text{C}$)
- Enable input for enabling / disabling the voltage regulator

Features

Max DC supply voltage	V_S	40 V
Max output voltage tolerance	ΔV_0	+/-2%
Max dropout voltage	V_{dp}	500 mV
Output current	I_O	300 mA
Quiescent current	I_{qn}	5 $\mu\text{A}^{(1)}$ 55 $\mu\text{A}^{(2)}$

1. Typical value with regulator disabled.
2. Typical value with regulator enabled.

- AEC-Q100 qualified 
- Operating DC supply voltage range
- 5.6 V to 40 V
- Low dropout voltage
- 300 mA current capability
- Low quiescent current
- Very low consumption mode
- Precision output voltage 5 V +/- 2%
- Reset circuit sensing the output voltage

Description

L5300GJ is a low dropout linear regulator with microprocessor control functions such as power on reset, low voltage reset, early warning, ON/OFF control. Typical quiescent current is 55 μA in very low output current mode and enabled regulator. It drops to 5 μA with not enabled regulator.

On-chip trimming results in high output voltage accuracy (2%). Accuracy is kept over wide temperature range, line and load variation. Early warning circuit monitors the input voltage and compares it with an internal voltage reference.

The maximum input voltage is 40 V. The maximum output current is internally limited.

Internal temperature protection disables the voltage regulator output. In addition, only low value ceramic capacitor on output is required for stability (equal or above 220 nF).

Table 1. Device summary

Package	Order codes	
	Tube	Tape and reel
PowerSSO-12	L5300GJ	L5300GJTR

Contents

- 1 Block diagram and pins description 5**

- 2 Electrical specifications 7**
 - 2.1 Absolute maximum ratings 7
 - 2.2 Thermal data 7
 - 2.3 Electrical characteristics 8
 - 2.4 Electrical characteristics curves 10

- 3 Application information 14**
 - 3.1 Voltage regulator 14
 - 3.2 Reset 16
 - 3.3 Early warning 16
 - 3.4 Enable 17

- 4 Package and PCB thermal data 18**

- 5 Package and packing information 21**
 - 5.1 ECOPACK® 21
 - 5.2 PowerSSO-12 mechanical data 21
 - 5.3 PowerSSO-12 packing information 23

- 6 Revision history 24**

List of tables

Table 1.	Device summary	1
Table 2.	Pins description	6
Table 3.	Absolute maximum ratings	7
Table 4.	Thermal data	7
Table 5.	General	8
Table 6.	Reset	9
Table 7.	Early warning	9
Table 8.	Enable.	9
Table 9.	PowerSSO-12 thermal parameter	20
Table 10.	PowerSSO-12 mechanical data	22
Table 11.	Document revision history	24

List of figures

Figure 1.	Block diagram	5
Figure 2.	Configuration diagram (top view)	5
Figure 3.	Output voltage vs T_j	10
Figure 4.	Output voltage vs V_S	10
Figure 5.	Output voltage vs V_{En}	10
Figure 6.	Drop voltage vs. output current	10
Figure 7.	Current consumption vs. output current	10
Figure 8.	Current consumption vs. output current (at light load condition)	10
Figure 9.	Current consumption vs input voltage ($I_o = 0.1$ mA)	11
Figure 10.	Current consumption vs input voltage ($I_o = 100$ mA)	11
Figure 11.	Current limitation vs T_j	11
Figure 12.	Current limitation vs input voltage	11
Figure 13.	Short-circuit current vs T_j	11
Figure 14.	Short-circuit current vs input voltage	11
Figure 15.	V_{En_high} vs T_j	12
Figure 16.	V_{En_low} vs T_j	12
Figure 17.	V_{Rth} vs T_j	12
Figure 18.	V_{Rlth} vs T_j	12
Figure 19.	V_{EWi_thh} vs T_j	12
Figure 20.	V_{EWi_thl} vs T_j	12
Figure 21.	I_{cr} vs T_j	13
Figure 22.	I_{dr} vs T_j	13
Figure 23.	Application schematic	14
Figure 24.	Stability region	15
Figure 25.	Maximum load variation response	15
Figure 26.	Reset time diagram	16
Figure 27.	Early warning time diagram	17
Figure 28.	PowerSSO-12 PC board ⁽¹⁾	18
Figure 29.	$R_{thj-amb}$ Vs. PCB copper area in open box free air condition	18
Figure 30.	PowerSSO-12 thermal impedance junction ambient single pulse	19
Figure 31.	Thermal fitting model of V_{reg} in in PowerSSO-12	19
Figure 32.	PowerSSO-12 package dimensions	21
Figure 33.	PowerSSO-12 tube shipment (no suffix)	23
Figure 34.	PowerSSO-12 tape and reel shipment (suffix "TR")	23

1 Block diagram and pins description

Figure 1. Block diagram

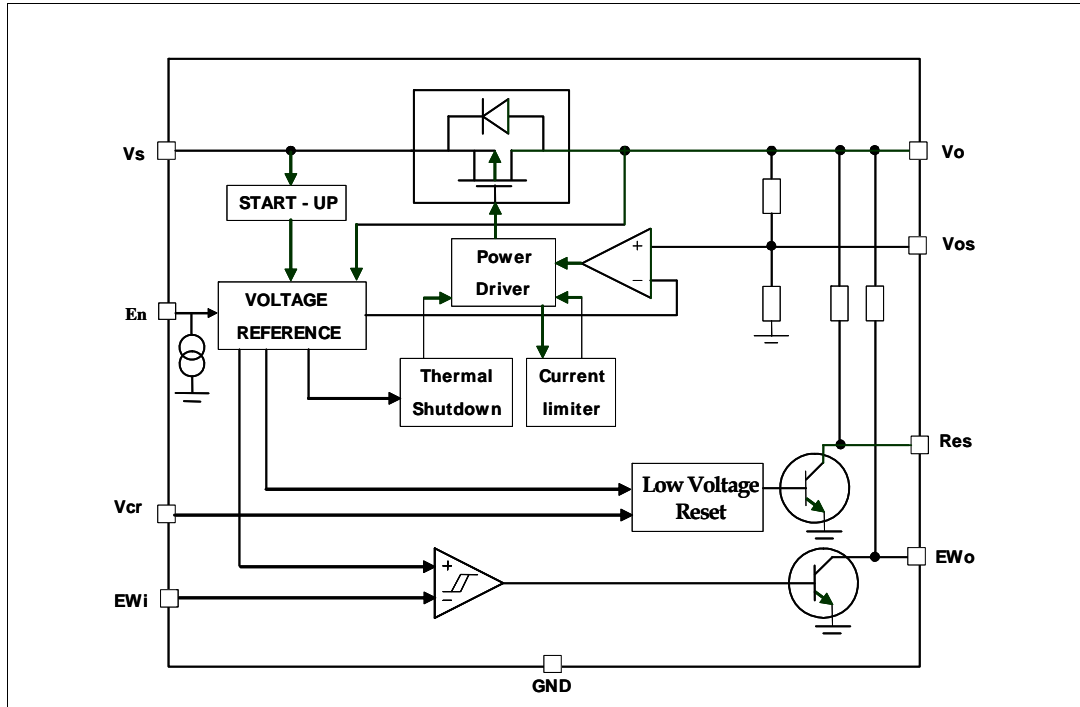

Figure 2. Configuration diagram (top view)

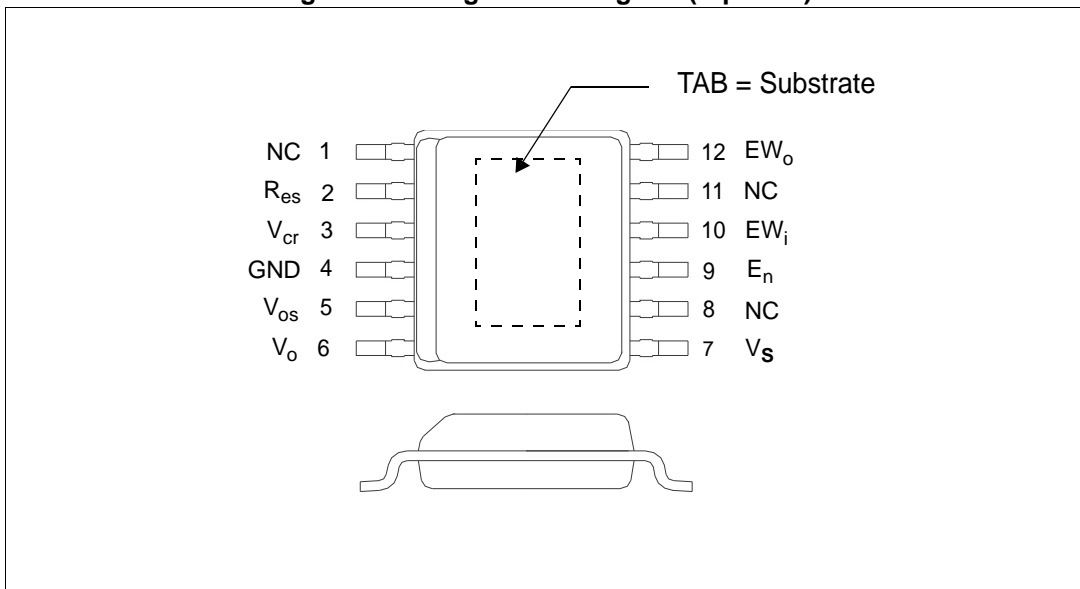

Table 2. Pins description

N°	Name	Function
1	NC	Not connected
2	R _{es}	Reset output. Internally connected to V _o through a 20 KΩ pull up resistor. This pin is pulled low when V _o < V _{o_th} . Keep open if not needed
3	V _{cr}	Reset delay. Connect an external capacitor between V _{cr} pin and ground to adjust the reset delay time. Keep open if not needed
4	GND	Ground reference
5	V _{os}	Regulator output voltage sensing (connect to V _o)
6	V _o	5 V regulated output. Block to GND with a ceramic capacitor (C _o ≥ 220 nF for regulator stability)
7	V _S	Supply voltage, block directly to GND on the IC with a capacitor
8	NC	Not connected
9	E _n	Enable input. A high signal switches the regulator ON. Connect to V _S if not needed
10	EW _i	Early warning input. This pin monitors the V _S voltage level through a resistor divider. Connect to V _S if not needed
11	NC	Not connected
12	EW _o	Early warning output. Internally connected to V _o through 20 KΩ pull up resistor. This pin is pulled low when EW _i is below bandgap reference voltage. Keep open if not needed
-	TAB	TAB is connected to the substrate of the chip: connect to GND or leave open (see Figure 2).

2 Electrical specifications

2.1 Absolute maximum ratings

Stressing the device above the rating listed in the [Table 3: Absolute maximum ratings](#) may cause permanent damage to the device. These are stress ratings only and operation of the device at these or any other conditions above those indicated in the operating sections of this specification is not implied. Exposure to absolute maximum rating conditions for extended periods may affect device reliability.

Table 3. Absolute maximum ratings

Symbol	Parameter	Value	Unit
V_{sdc}	DC supply voltage	-0.3 to 40	V
I_{Vsdc}	Input current	Internally limited	
V_{odc}	DC output voltage	-0.3 to 6	V
I_{Vodc}	DC output current	Internally limited	
$V_{od Res}$	Open drain output voltage R_{es}	-0.3 to $V_{odc} + 0.3$	V
$I_{od Res}$	Open drain output current R_{es}	Internally limited	
$V_{od EW_o}$	Open drain output voltage EW_o	-0.3 to $V_{odc} + 0.3$	V
$I_{od EW_o}$	Open drain output current EW_o	Internally limited	
V_{cr}	V_{cr} voltage	-0.3 to $V_o + 0.3$	V
V_{EWi}	Early warning input voltage	-0.3 to 40	V
V_{En}	Enable input	-0.3 to 40	V
T_j	Junction temperature	-40 to 150	°C
$V_{ESD HBM}$	ESD HBM voltage level (HBM-MIL STD 883C)	+/- 2	kV
$V_{ESD CDM}$	ESD CDM voltage level (CDM AEC-Q100-011)	+/- 750	V

2.2 Thermal data

Table 4. Thermal data

Symbol	Parameter	Value	Unit
$R_{thj-case}$	Thermal resistance junction to case: PowerSSO-12	8	°K/W
$R_{thj-amb}$	Thermal resistance junction to ambient: PowerSSO-12	48	°K/W

Note: The values quoted are for PCB 77mm x 86 mm x 1.6mm, FR4, double layer with thermal vias (one copper heatsink layer, thickness 0.070 mm, area 8 cm²).

2.3 Electrical characteristics

Values specified in this section are for $V_S = 5.6\text{ V to }31\text{ V}$, $T_j = -40^\circ\text{C to }150^\circ\text{C}$ unless otherwise stated.

Table 5. General

Pin	Symbol	Parameter	Test condition	Min.	Typ.	Max.	Unit
V_o	V_{o_ref}	Output voltage	$V_S = 8\text{ V to }18\text{ V}$; $I_o = 8\text{ mA to }300\text{ mA}$	4.9	5.0	5.1	V
V_o	V_{o_ref}	Output voltage	$V_S = 5.6\text{ V to }31\text{ V}$; $I_o = 8\text{ mA to }300\text{ mA}$	4.85	5.0	5.15	V
V_o	V_{o_ref}	Output voltage	$V_S = 5.6\text{ V to }31\text{ V}$; $I_o = 0.1\text{ mA to }8\text{ mA}$	4.75	5.0	5.25	V
V_o	I_{short}	Short circuit current	$V_S = 13.5\text{ V}$	0.8	1.8	2.6	A
V_o	I_{lim}	Output current capability ⁽¹⁾	$V_S = 13.5\text{ V}$	0.6	1.6	2.5	A
V_S, V_o	V_{line}	Line regulation voltage	$V_S = 6\text{ V to }28\text{ V}$; $I_o = 60\text{ mA}$			40	mV
V_o	V_{load}	Load regulation voltage	$V_S = 13.5\text{ V}$; $I_o = 8\text{ mA to }300\text{ mA}$; $T_j = 25^\circ\text{C}$			40	mV
			$V_S = 8\text{ V to }18\text{ V}$; $I_o = 8\text{ mA to }300\text{ mA}$			55	
V_S, V_o	V_{dp}	Drop voltage ⁽²⁾	$I_o = 300\text{ mA}$			500	mV
V_S, V_o	SVR	Ripple rejection	$f_r = 100\text{ Hz}$ ⁽³⁾		60		dB
V_o	I_{oth_H}	Normal consumption mode output current		8			mA
V_o	I_{oth_L}	Very low consumption mode output current				1.1	mA
V_o	I_{oth_Hyst}	Output current switching threshold hysteresis	$V_S = 13.5\text{ V}$; $T_j = 25^\circ\text{C}$		0.8		mA
V_S, V_o	I_{qs}	Current consumption with regulator disabled $I_{qs} = I_{V_S} - I_o$	$V_S = 13.5\text{ V}$; $E_n = \text{low}$		5	10	μA
V_S, V_o	I_{qn_1}	Current consumption with regulator enabled $I_{qn_1} = I_{V_S} - I_o$	$V_S = 13.5\text{ V}$; $I_o = 0.1\text{ mA to }1\text{ mA}$; $E_n = \text{high}$		55	80	μA
V_S, V_o	I_{qn_300}	Current consumption with regulator enabled $I_{qn_300} = I_{V_S} - I_o$	$V_S = 13.5\text{ V}$; $I_o = 300\text{ mA}$; $E_n = \text{high}$		3	4.2	mA
	T_w	Thermal protection temperature		150		190	$^\circ\text{C}$
	T_{w_hy}	Thermal protection temperature hysteresis			10		$^\circ\text{C}$

1. Measured output current when the output voltage has dropped 100 mV from its nominal value obtained at 13.5 V and $I_o = 75\text{ mA}$.

2. $V_S - V_O$ measured dropout when the output voltage has dropped 100 mV from its nominal value obtained at 13.5V and $I_O = 75$ mA.
3. Guaranteed by design.

Table 6. Reset

Pin	Symbol	Parameter	Test condition	Min.	Typ.	Max.	Unit
R _{es}	V _{Res_l}	Reset output low voltage	R _{ext} = 5 kΩ; V _o > 1 V			0.4	V
R _{es}	I _{Res_lkg}	Reset output high leakage current	V _{Res} = V _{out}			1	μA
R _{es}	R _{res}	Pull-up internal resistance	Versus V _o	10	20	40	kΩ
R _{es}	V _{o_th}	V _o out of regulation threshold	V _o decreasing	6	8	10	%below V _{o_ref}
V _{cr}	V _{Rlth}	Reset timing low threshold	V _S = 13.5 V	15	18	22	% V _{o_ref}
V _{cr}	V _{Rhth}	Reset timing high threshold	V _S = 13.5 V	47	50	53	% V _{o_ref}
V _{cr}	I _{cr}	Charge current	V _S = 13.5 V	10	20	30	μA
V _{cr}	I _{dr}	Discharge current	V _S = 13.5 V	10	20	30	μA
R _{es}	T _{rr}	Reset reaction time				2	μs
R _{es}	T _{rd}	Reset delay time	V _S = 13.5 V; C _{tr} = 1 nF	2	4	6	ms

Table 7. Early warning

Pin	Symbol	Parameter	Test condition	Min.	Typ.	Max.	Unit
EW _i	E _{wi_th_low}	EW input low threshold voltage		2.35	2.50	2.65	V
EW _i	E _{wi_th_high}	EW input high threshold voltage		2.42	2.57	2.72	V
EW _i	E _{wi_th_hyst}	EW input threshold hysteresis			70		mV
EW _i	I _{EWi_lkg}	EW input leakage current	V _{EWi} = 0 V; V _S > 3 V	-1		1	μA
EW _o	R _{EWo}	Pull-up internal resistance	Versus V _o	10	20	40	kΩ
EW _o	E _{Wo_lv}	EW output low voltage (with external pull up)	V _{EWi} < 2.35 V; V _S > 4 V; R _{ext} = 5 kΩ			400	mV
EW _o	I _{Wo}	EW output leakage	V _{EWo} = 5 V			1	μA

Table 8. Enable

Pin	Symbol	Parameter	Test condition	Min.	Typ.	Max.	Unit
E _n	V _{En_low}	E _n input low voltage				1	V
E _n	V _{En_high}	E _n input high voltage		3			V
E _n	V _{En_hyst}	E _n input hysteresis			500		mV
E _n	I _{leak}	Pull-down current	V _{En} = 5 V		3	10	μA

2.4 Electrical characteristics curves

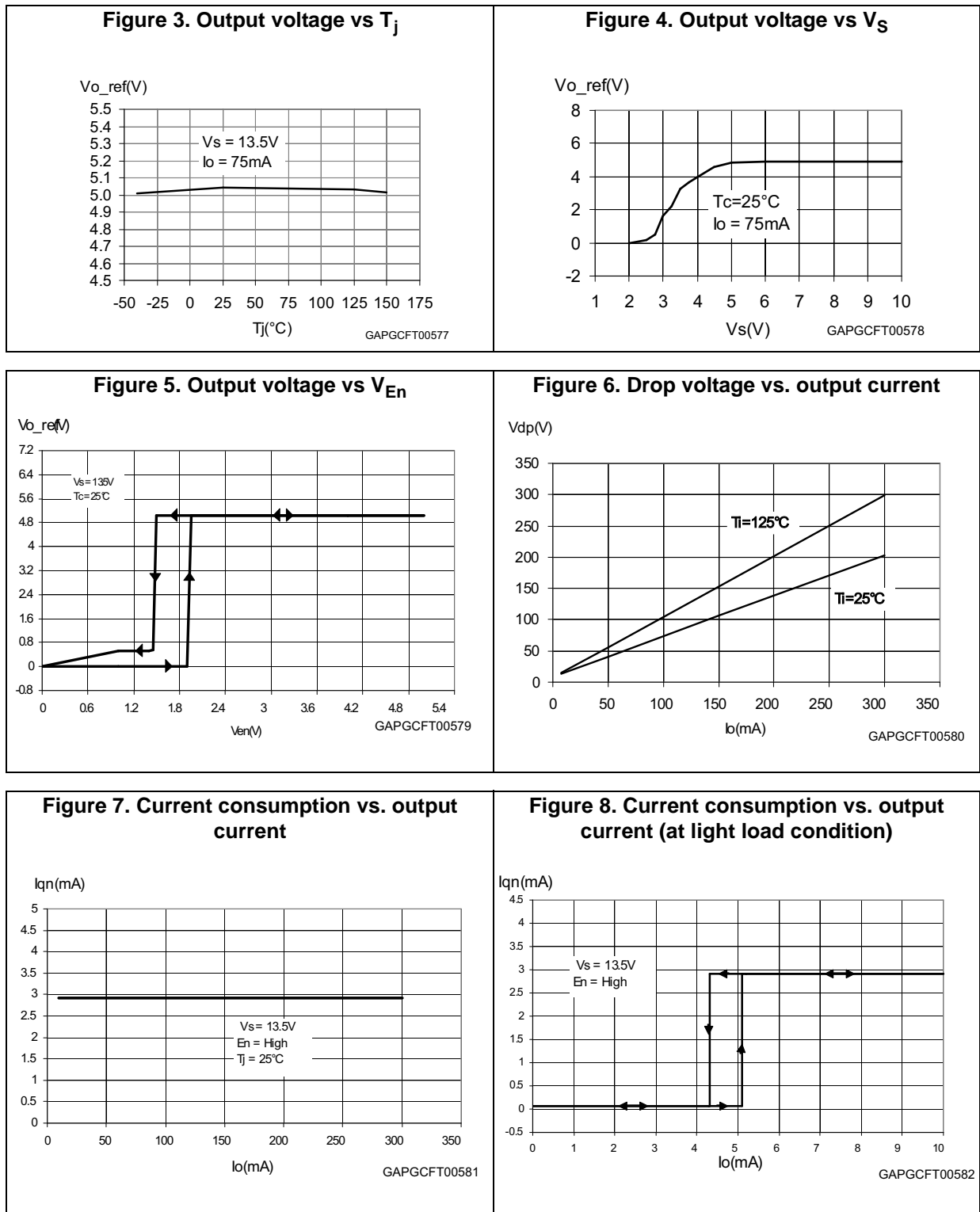

Figure 9. Current consumption vs input voltage
($I_o = 0.1 \text{ mA}$)

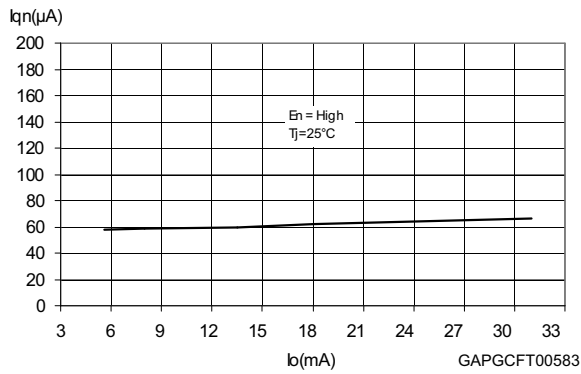

Figure 10. Current consumption vs input voltage
($I_o = 100 \text{ mA}$)

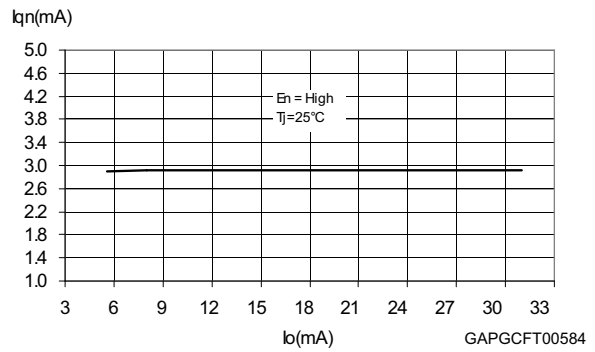

Figure 11. Current limitation vs T_j

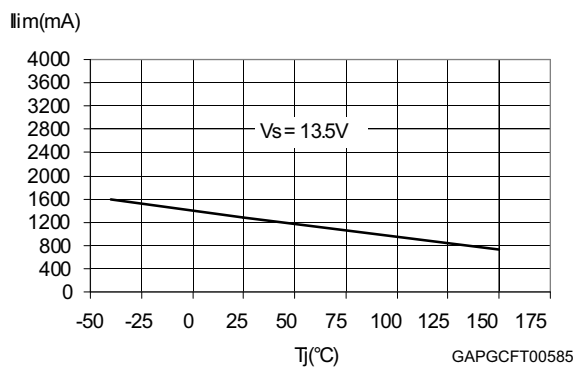

Figure 12. Current limitation vs input voltage

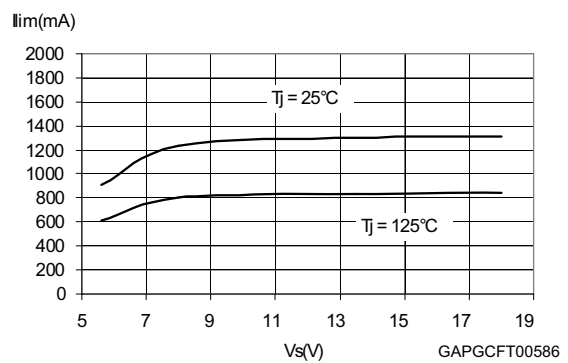

Figure 13. Short-circuit current vs T_j

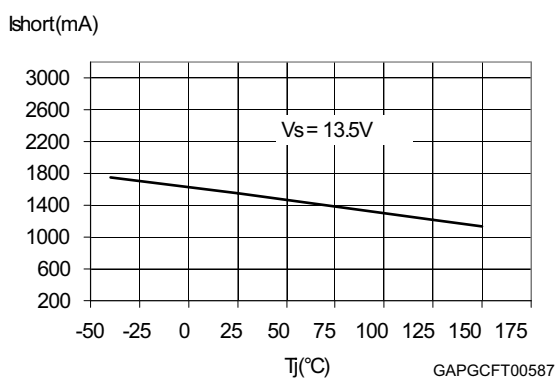
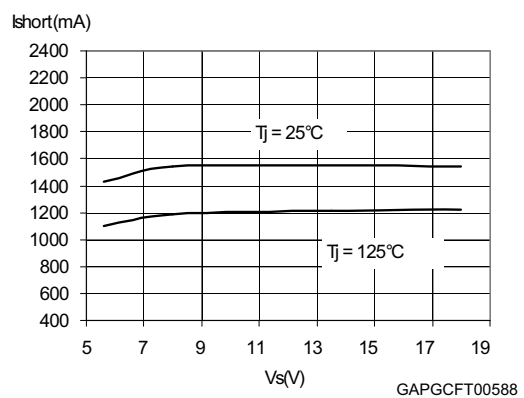
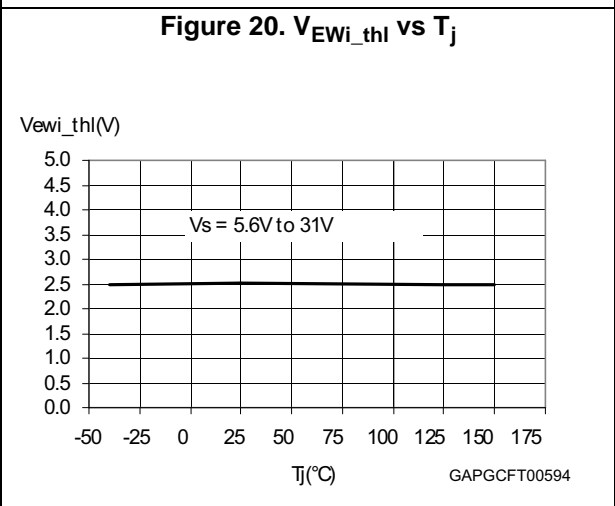
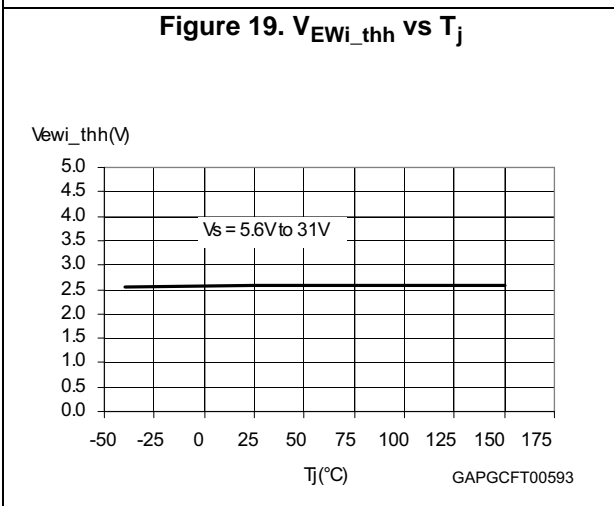
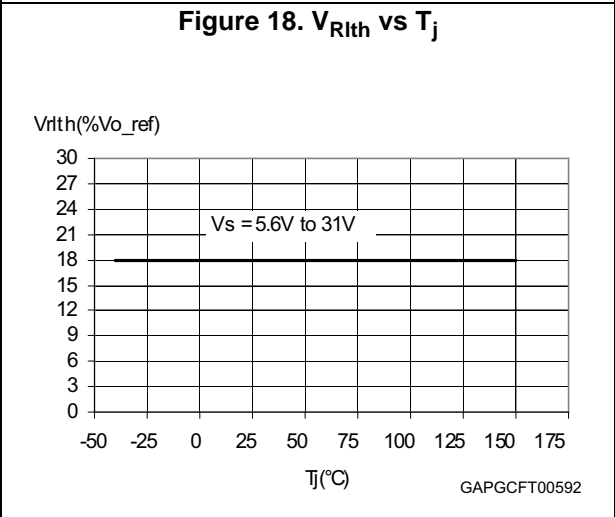
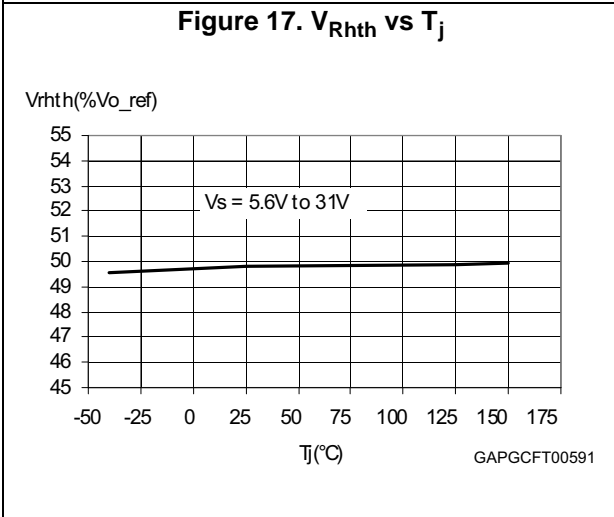
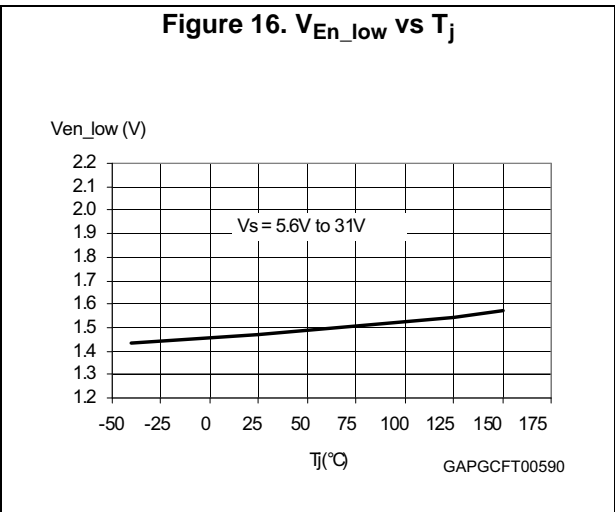
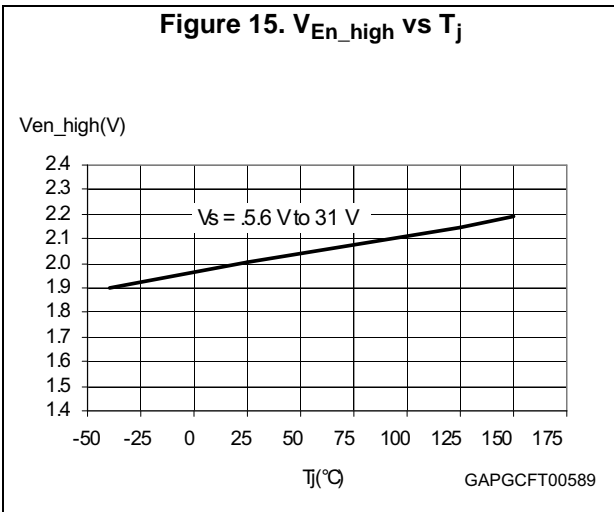
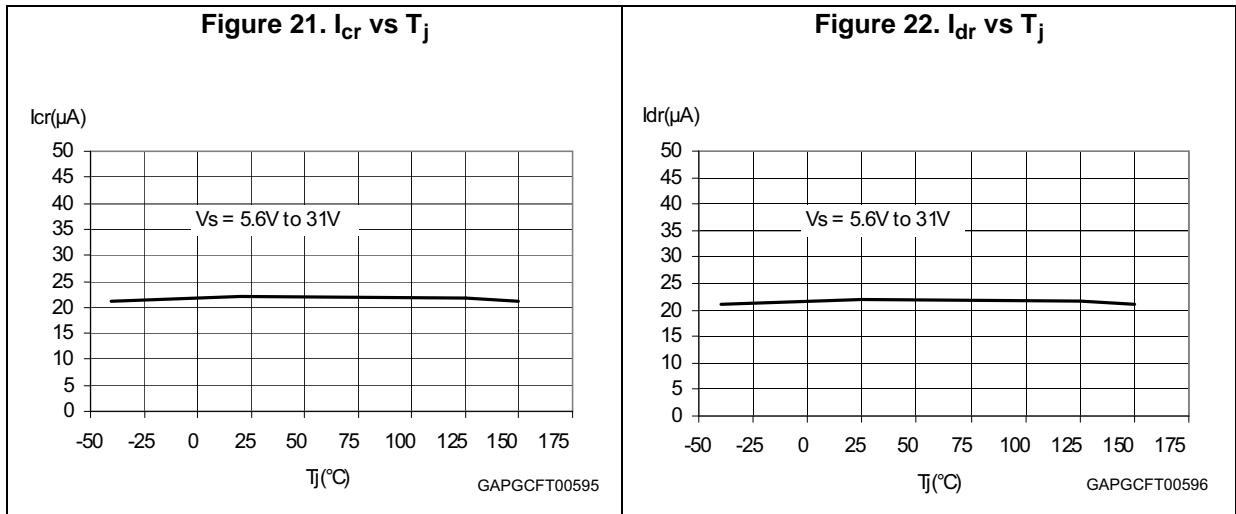

Figure 14. Short-circuit current vs input voltage







3 Application information

3.1 Voltage regulator

The voltage regulator uses a p-channel mos transistor as a regulating element. With this structure a very low dropout voltage at current up to 300 mA is obtained. The output voltage is regulated up to input supply voltage of 40 V. The high-precision of the output voltage (2%) is obtained with a pre-trimmed reference voltage. The voltage regulator automatically adapts its own quiescent current to the output current level. In light load conditions the quiescent current goes down to 55 μ A only (low consumption mode). This procedure features a certain hysteresis on the output current (see [Figure](#)). Short-circuit protection to GND and a thermal shutdown are provided.

Figure 23. Application schematic

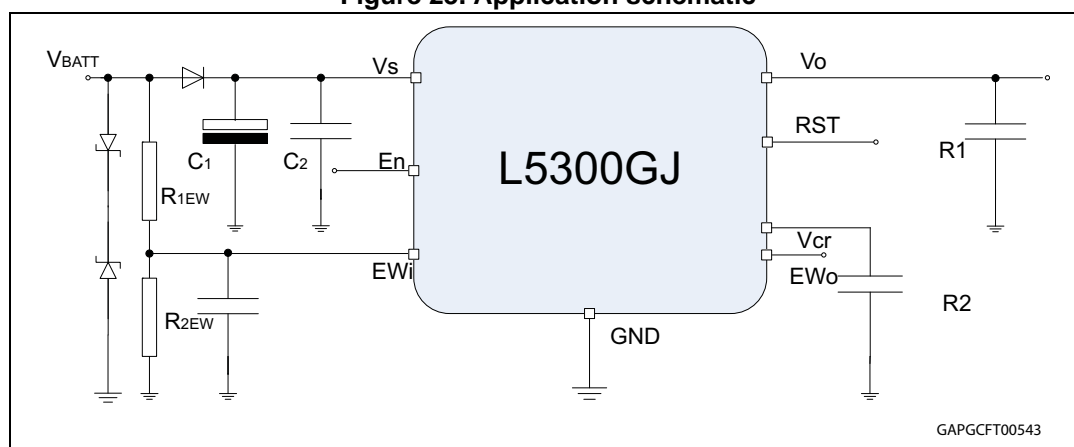

The input capacitor $C_1 \geq 100 \mu\text{F}$ is necessary as backup supply for negative pulses which may occur on the line. The second input capacitor $C_2 \geq 220 \text{ nF}$ is needed when the C_1 is too distant from the V_S pin and it compensates smooth line disturbances. The C_0 ceramic capacitor, connected to the output pin, is for bypassing to GND the high-frequency noise and it guarantees stability even during sudden line and load variations. Suggested value is $C_0 = 220 \text{ nF}$ with $\text{ESR} \geq 100 \text{ m}\Omega$.

Stability region is reported in [Figure 24](#).

Figure 24. Stability region

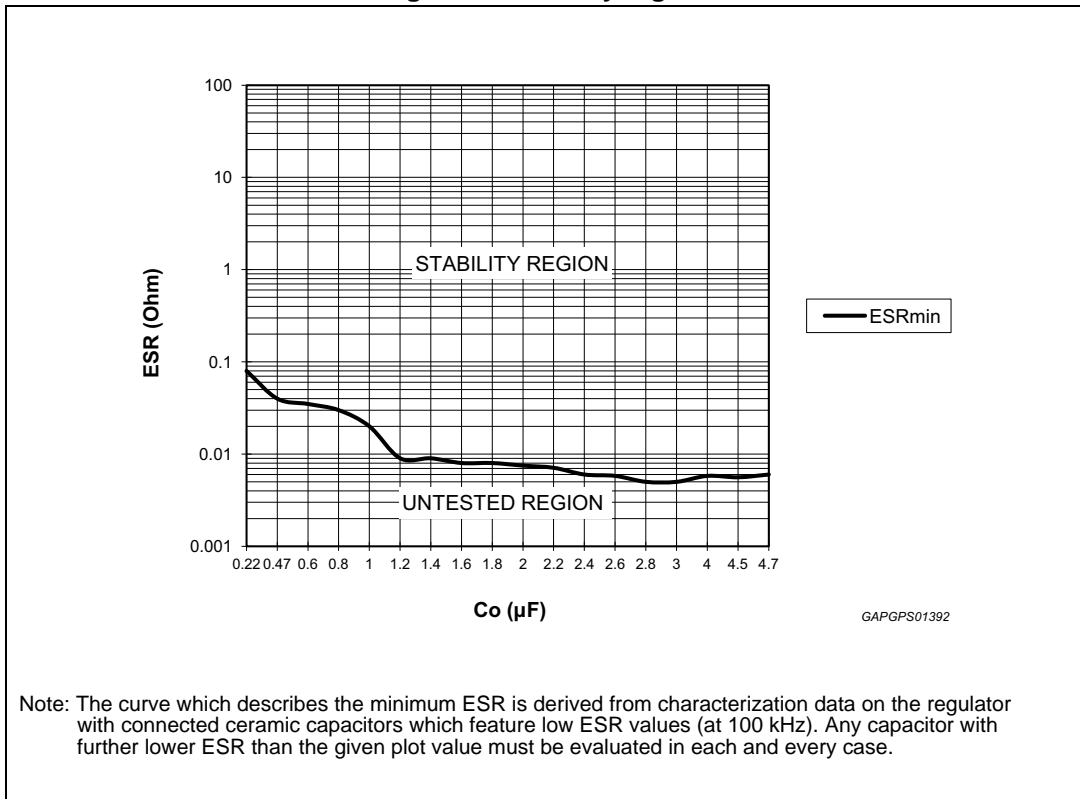
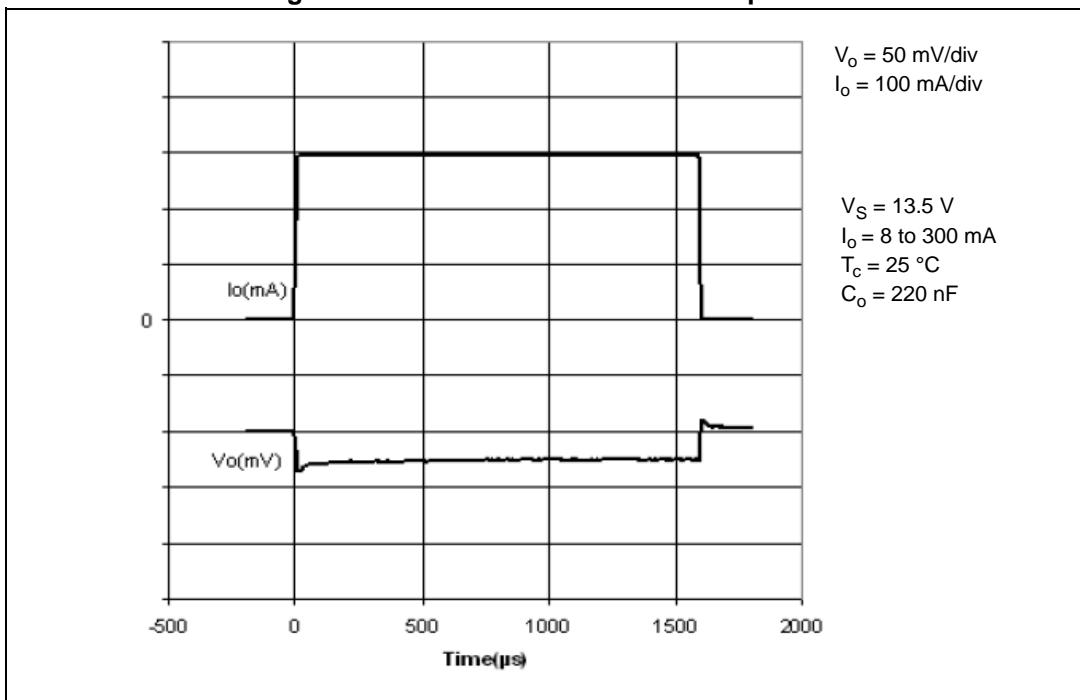

Figure 25. Maximum load variation response



3.2 Reset

The reset circuit monitors the output voltage V_o . If the output voltage becomes lower than V_{o_th} then R_{es} goes low with a delay time (t_{rr}). When the output voltage becomes higher than V_{o_th} then R_{es} goes high with a delay time T_{rd} . This delay is obtained by 32 periods of oscillator.

The oscillator period is given by:

Equation 1

$$T_{osc} = [(V_{Rhth} - V_{Rlth}) \times C_{tr}] / I_{cr} + [(V_{Rhth} - V_{Rlth}) \times C_{tr}] / I_{dr}$$

where:

- $I_{cr} = 20 \mu A$ is an internally generated charge current,
- $I_{dr} = 20 \mu A$ is an internally generated discharge current,
- $V_{Rhth} = 2.5 V$ (typ) and $V_{Rlth} = 0.95 V$ (typ) are two voltage thresholds,
- C_{tr} is an external capacitor to be put between V_{cr} pin and GND.

Reset pulse delay T_{rd} is given by:

Equation 2

$$T_{rd} = 32 \times T_{osc}$$

Figure 26. Reset time diagram

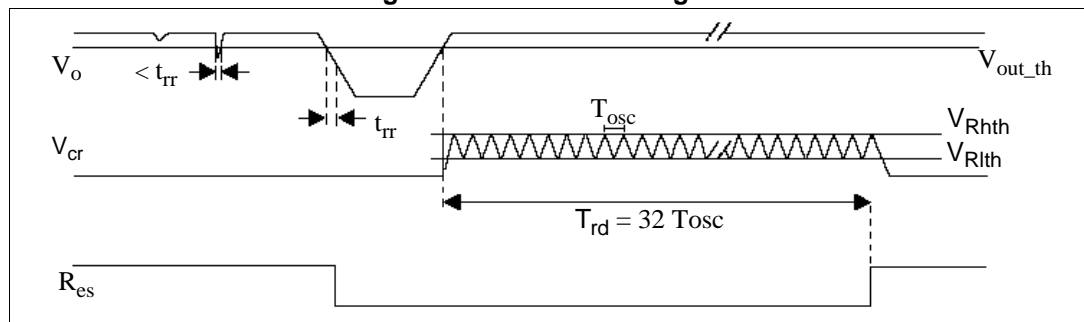

3.3 Early warning

This circuit compares the EW_i input signal with the internal voltage reference (typically 2.5 V). The use of an external voltage divider makes the comparator very flexible in the application. This function can be used to supervise the supply input voltage either before or after the protection diode and to give additional information to the microprocessor such as low voltage warnings.

Figure 27. Early warning time diagram

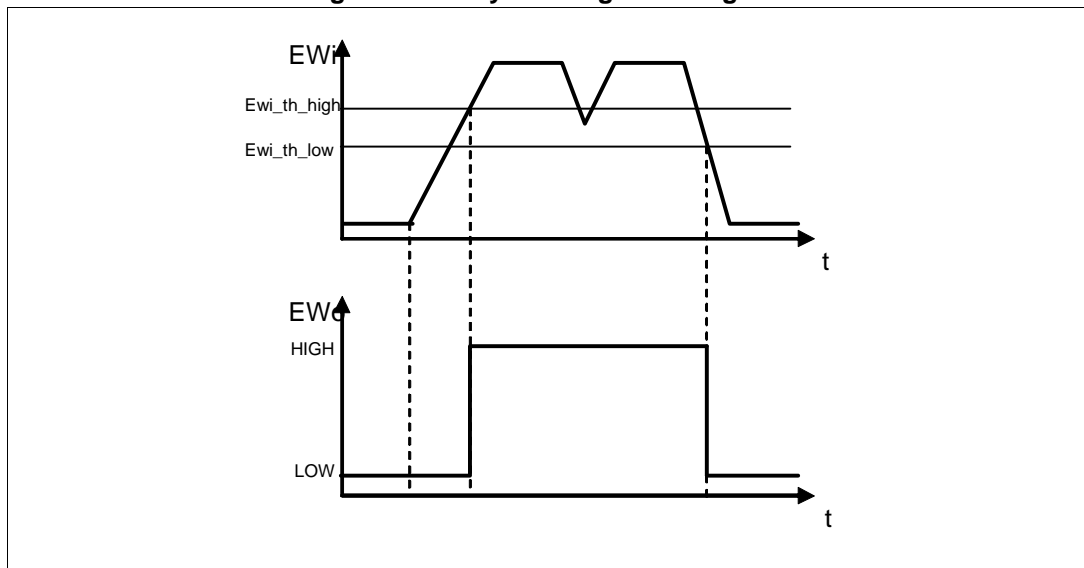

3.4 Enable

L5300GJ is also provided with an enable input, a high signal switches the regulator ON. In standby mode the output is disabled and the current consumption of the device (quiescent current) is less than 10 μA .

4 Package and PCB thermal data

Figure 28. PowerSSO-12 PC board⁽¹⁾

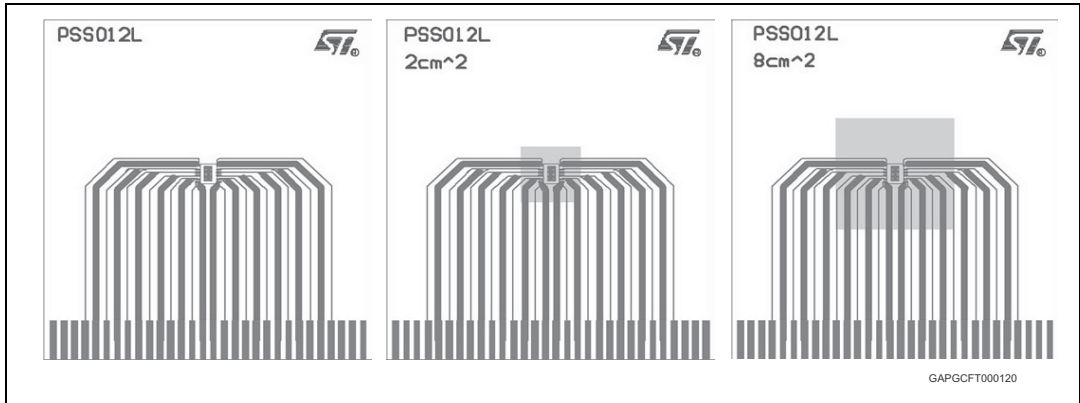

1. Layout condition of R_{th} and Z_{th} measurements (PCB: double layer, thermal vias, FR4 area = 77 mm x 86 mm, PCB thickness = 1.6 mm, Cu thickness = 70 μ m (front and back side), thermal vias separation 1.2 mm, thermal via diameter 0.3 mm +/- 0.08 mm, Cu thickness on vias 0.025 mm, Footprint dimension 4.1 mm x 6.5 mm).

Figure 29. $R_{thj-amb}$ Vs. PCB copper area in open box free air condition

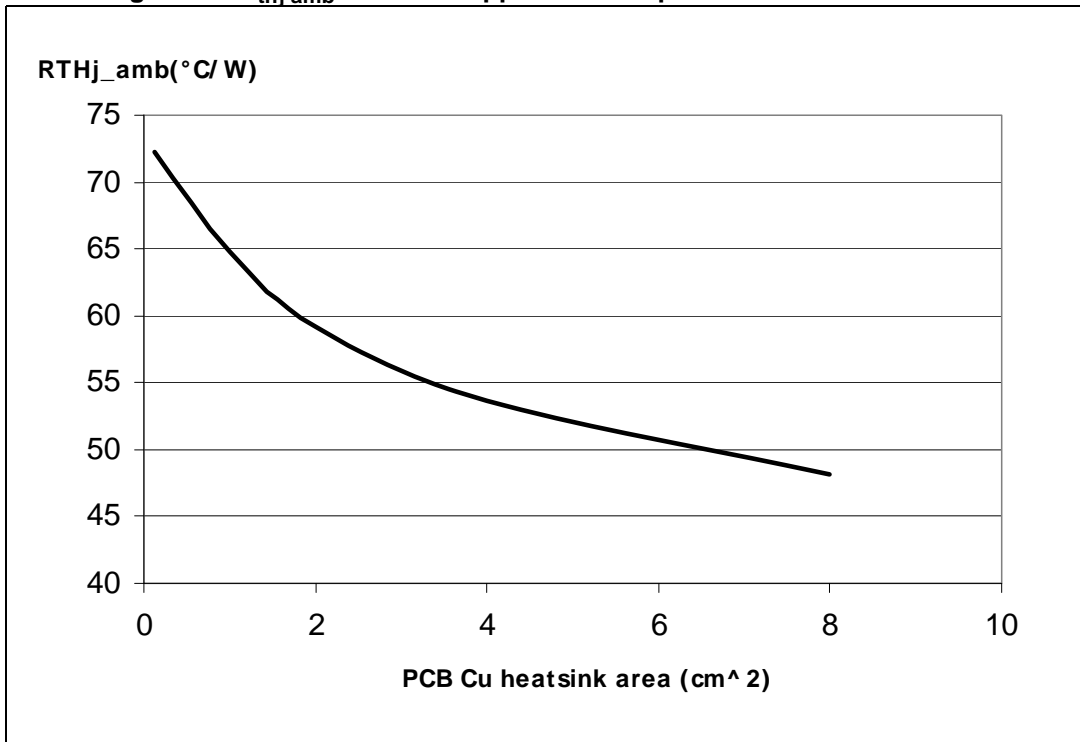
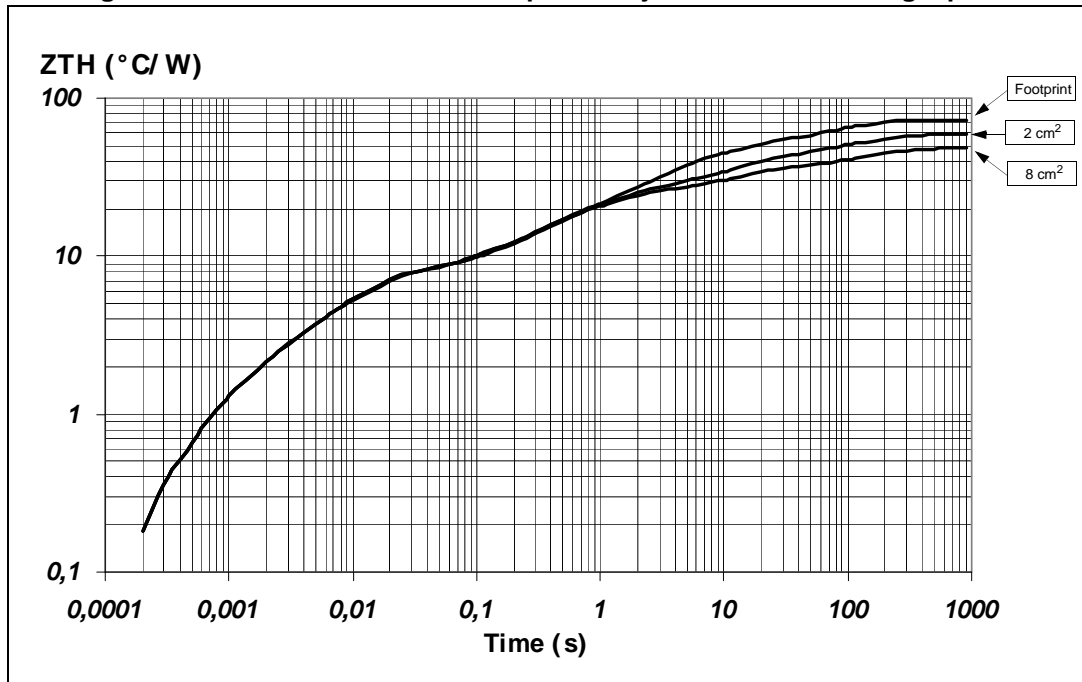

Figure 30. PowerSSO-12 thermal impedance junction ambient single pulse



Equation 3: pulse calculation formula

$$Z_{TH\delta} = R_{TH} \cdot \delta + Z_{THtp}(1 - \delta)$$

where $\delta = t_p/T$

Figure 31. Thermal fitting model of Vreg in in PowerSSO-12

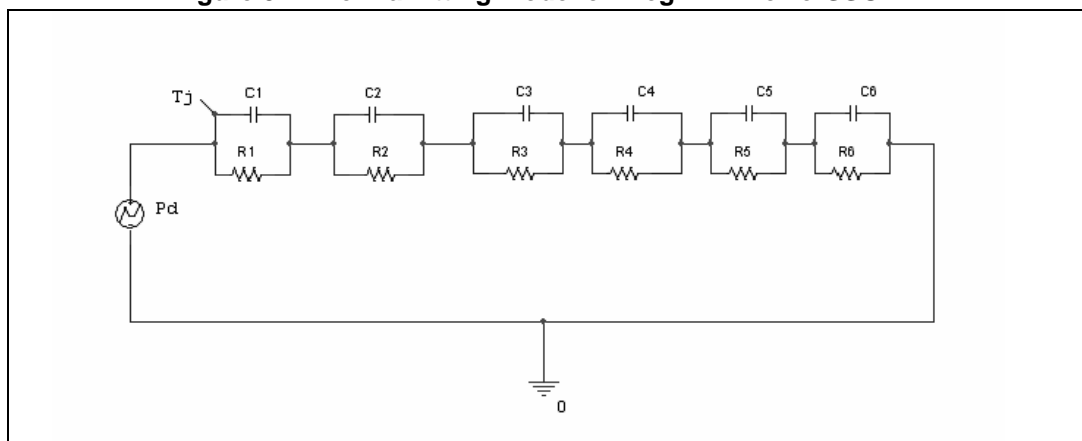

Table 9. PowerSSO-12 thermal parameter

Area (cm ²)	Footprint	2	8
R1 (°C/W)	1.2		
R2 (°C/W)	6		
R3 (°C/W)	7		
R4 (°C/W)	10	10	9
R5 (°C/W)	22	15	10
R6 (°C/W)	26	20	15
C1 (W.s/°C)	0.0008		
C2 (W.s/°C)	0.0016		
C3 (W.s/°C)	0.05		
C4 (W.s/°C)	0.2	0.1	0.1
C5 (W.s/°C)	0.27	0.8	1
C6 (W.s/°C)	3	6	9

5 Package and packing information

5.1 ECOPACK®

In order to meet environmental requirements, ST offers these devices in different grades of ECOPACK® packages, depending on their level of environmental compliance. ECOPACK® specifications, grade definitions and product status are available at: www.st.com. ECOPACK® is an ST trademark.

5.2 PowerSSO-12 mechanical data

Figure 32. PowerSSO-12 package dimensions

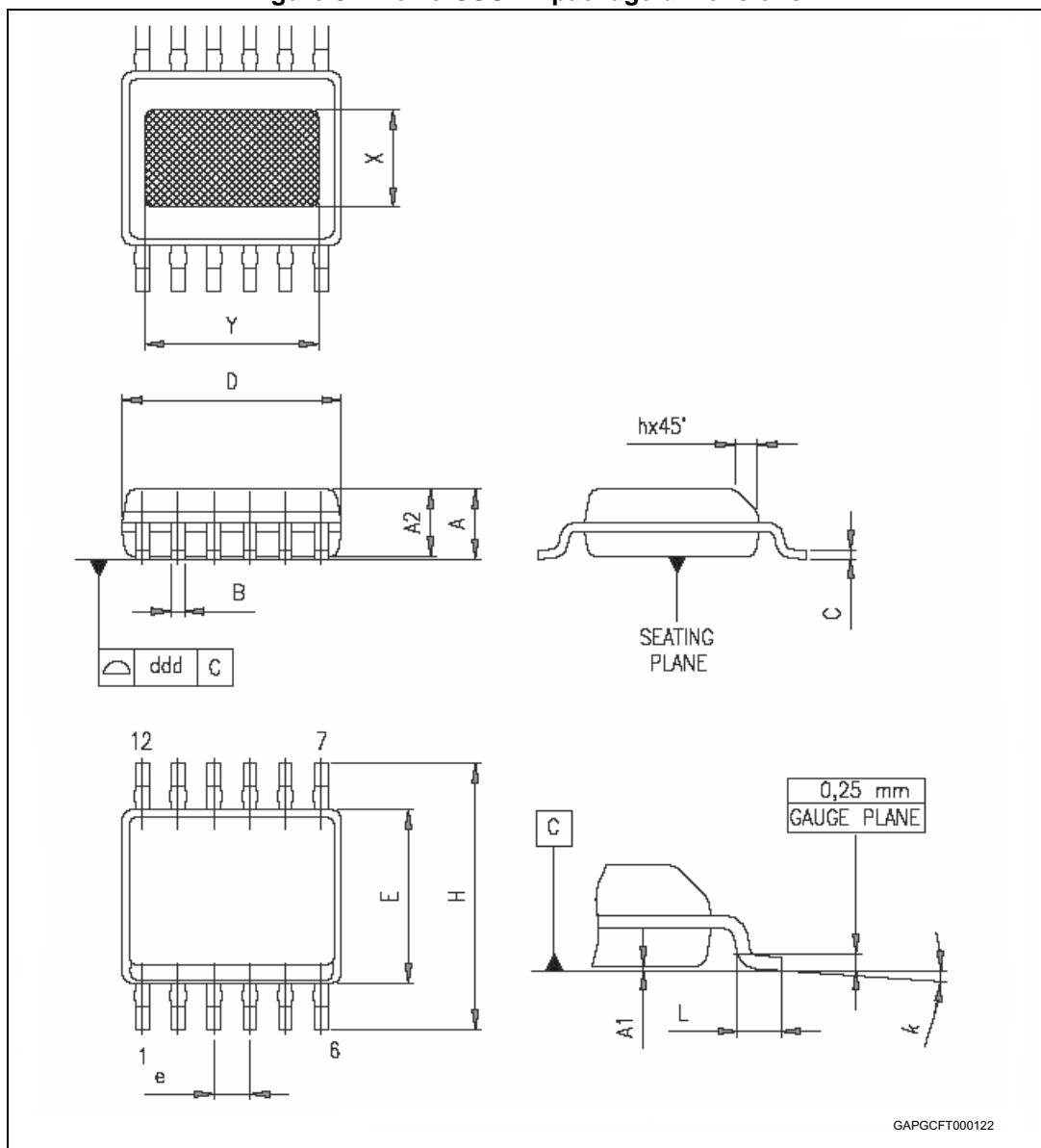

Table 10. PowerSSO-12 mechanical data

Symbol	Millimeters		
	Min.	Typ.	Max.
A	1.250		1.620
A1	0.000		0.100
A2	1.100		1.650
B	0.230		0.410
C	0.190		0.250
D	4.800		5.000
E	3.800		4.000
e		0.800	
H	5.800		6.200
h	0.250		0.500
L	0.400		1.270
k	0°		8°
X	2.200		2.800
Y	2.900		3.500
ddd			0.100

5.3 PowerSSO-12 packing information

Figure 33. PowerSSO-12 tube shipment (no suffix)

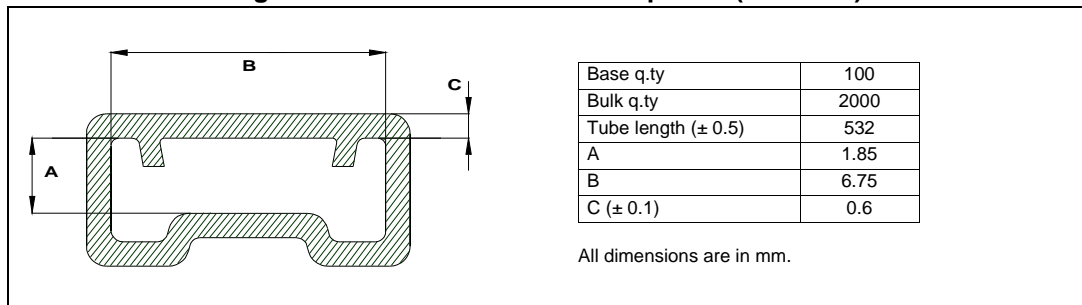
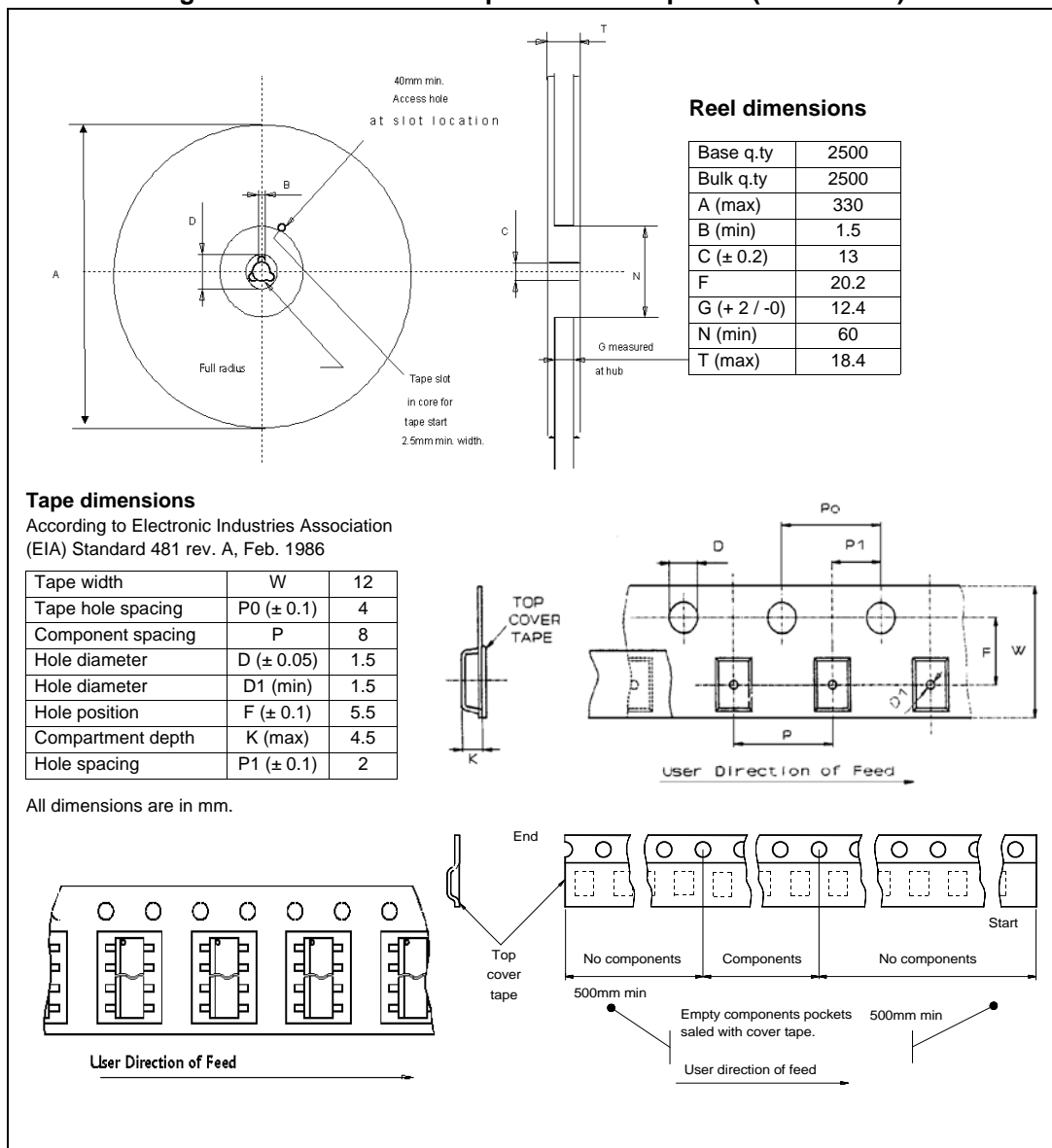

Figure 34. PowerSSO-12 tape and reel shipment (suffix "TR")



6 Revision history

Table 11. Document revision history

Date	Revision	Changes
09-Aug-2007	1	Initial release.
17-Sep-2008	2	<p>Changed rev. numbering according with new "Target" standard. Updated quiescent currents on Features table. Updated Description on cover page. Changed Figure 1: Block diagram. Updated Figure 2: Configuration diagram (top view): – added pin names. Updated Table 2: Pins description: – changed pin 5 from NC to V_{os} Added values to Table 4: Thermal data. Updated Table 5.: General: – updated test condition on V_{o_ref} – changed I_{short} values – changed I_{lim} values – updated test condition on V_{line} – updated test condition on V_{load} – Inserted I_{oth_H} – Inserted I_{oth_L} – Inserted I_{oth_Hyst} Updated Table 6: Reset: – updated test condition on V_{res_l} – updated test condition on V_{o_th} – changed V_{Rlth} values – deleted test condition on T_{rr} – changed T_{rd} values Updated Table 7: Early warning: – updated test condition on E_{Wo_lv} – updated test condition on I_{Wo} Updated Table 8: Enable: – changed typ. value on V_{En_hyst} – updated test condition on I_{leak} Updated Chapter 3: Application information – deleted Figure 3: Behavior of output current versus regulated voltage V_o – updated Section 3.2: Reset – updated Section 3.4: Enable Added Chapter 4: Package and PCB thermal data. Updated Table 10: PowerSSO-12 mechanical data: – changed slug dimensions – $I_o = 1$ to 300 mA</p>

Table 11. Document revision history (continued)

Date	Revision	Changes
13-Mar-2009	3	<p>Table 2: Pins description</p> <ul style="list-style-type: none"> – V_{OS}: changed function <p>Table 6: Reset</p> <ul style="list-style-type: none"> – I_{Res_Ikg}: deleted $V_{Res} = 5$ V from Test condition – V_{O_th}: deleted $I_o = 1$ mA to 300 mA from Test condition – V_{Rlth}: changed min/typ/max values – T_{rd}: changed min/typ/max values <p>Section 3.2: Reset</p> <ul style="list-style-type: none"> – V_{Rlth}: changed coefficient <p>Section 3.4: Enable</p> <ul style="list-style-type: none"> – Replaced 5 μA with 10 μA
07-Dec-2009	4	<p>Updated corporate template (from V2 to V3)</p> <p>Updated features list.</p> <p>Updated Figure 2: Configuration diagram (top view)</p> <p>Table 2: Pins description</p> <ul style="list-style-type: none"> – Added new row <p>Table 5: General</p> <ul style="list-style-type: none"> – I_{short}: changed min/typ/max value – I_{lim}: changed min/typ/max value – V_{line}: changed Test conditions – V_{load}: changed max value for $V_s = 8$ V to 18 V, added new row <p>Table 6: Reset</p> <ul style="list-style-type: none"> – V_{Rlth}: changed min/typ value <p>Table 8: Enable</p> <ul style="list-style-type: none"> – I_{leak}: changed typ value <p>Section 3.3: Early warning</p> <ul style="list-style-type: none"> – changed typical internal voltage reference value (from 1.23 V to 2.5 V) <p>Added Section 2.4: Electrical characteristics curves.</p> <p>Updated Chapter 3.1: Voltage regulator.</p>
27-Jan-2012	5	Updated Figure 23: Application schematic and Figure 24: Stability region .
07-Feb-2012	6	Modified Figure 24: Stability region on page 15 .
19-Sep-2013	7	Updated disclaimer.
26-Sep-2018	8	Updated template. Updated Features and title.

IMPORTANT NOTICE – PLEASE READ CAREFULLY

STMicroelectronics NV and its subsidiaries ("ST") reserve the right to make changes, corrections, enhancements, modifications, and improvements to ST products and/or to this document at any time without notice. Purchasers should obtain the latest relevant information on ST products before placing orders. ST products are sold pursuant to ST's terms and conditions of sale in place at the time of order acknowledgement.

Purchasers are solely responsible for the choice, selection, and use of ST products and ST assumes no liability for application assistance or the design of Purchasers' products.

No license, express or implied, to any intellectual property right is granted by ST herein.

Resale of ST products with provisions different from the information set forth herein shall void any warranty granted by ST for such product.

ST and the ST logo are trademarks of ST. All other product or service names are the property of their respective owners.

Information in this document supersedes and replaces information previously supplied in any prior versions of this document.

© 2018 STMicroelectronics – All rights reserved



Компания «ЭлектроПласт» предлагает заключение долгосрочных отношений при поставках импортных электронных компонентов на взаимовыгодных условиях!

Наши преимущества:

- Оперативные поставки широкого спектра электронных компонентов отечественного и импортного производства напрямую от производителей и с крупнейших мировых складов;
- Поставка более 17-ти миллионов наименований электронных компонентов;
- Поставка сложных, дефицитных, либо снятых с производства позиций;
- Оперативные сроки поставки под заказ (от 5 рабочих дней);
- Экспресс доставка в любую точку России;
- Техническая поддержка проекта, помощь в подборе аналогов, поставка прототипов;
- Система менеджмента качества сертифицирована по Международному стандарту ISO 9001;
- Лицензия ФСБ на осуществление работ с использованием сведений, составляющих государственную тайну;
- Поставка специализированных компонентов (Xilinx, Altera, Analog Devices, Intersil, Interpoint, Microsemi, Aeroflex, Peregrine, Syfer, Eurofarad, Texas Instrument, Miteq, Cobham, E2V, MA-COM, Hittite, Mini-Circuits, General Dynamics и др.);

Помимо этого, одним из направлений компании «ЭлектроПласт» является направление «Источники питания». Мы предлагаем Вам помощь Конструкторского отдела:

- Подбор оптимального решения, техническое обоснование при выборе компонента;
- Подбор аналогов;
- Консультации по применению компонента;
- Поставка образцов и прототипов;
- Техническая поддержка проекта;
- Защита от снятия компонента с производства.



Как с нами связаться

Телефон: 8 (812) 309 58 32 (многоканальный)

Факс: 8 (812) 320-02-42

Электронная почта: org@eplast1.ru

Адрес: 198099, г. Санкт-Петербург, ул. Калинина, дом 2, корпус 4, литера А.