

Wide Input 2A Step Down Converter

FEATURES

- 2A Output Current
- Up to 96% Efficiency
- 4.5V to 24V Input Range
- 10 μ A Shutdown Supply Current
- 400kHz Switching Frequency
- Adjustable Output Voltage
- Cycle-by-Cycle Current Limit Protection
- Thermal Shutdown Protection
- Frequency FoldBack at Short Circuit
- Stability with Wide Range of Capacitors, Including Low ESR Ceramic Capacitors
- SOP-8 Package

APPLICATIONS

- TFT LCD Monitors
- Portable DVDs
- Car-Powered or Battery-Powered Equipments
- Set-Top Boxes
- Telecom Power Supplies
- DSL and Cable Modems and Routers
- Termination Supplies

GENERAL DESCRIPTION

The ACT4060A is a current-mode step-down DC/DC converter that provides up to 2A of output current at 400kHz switching frequency. The device utilizes Active-Semi's proprietary high voltage process for operation with input voltages up to 24V.

The ACT4060A provides fast transient response and eases loop stabilization while providing excellent line and load regulation. This device features a very low ON-resistance power MOSFET which provides peak operating efficiency up to 96%. In shutdown mode, the ACT4060A consumes only 10 μ A of supply current.

This device also integrates protection features including cycle-by-cycle current limit, thermal shutdown and frequency fold-back at short circuit.

The ACT4060A is available in a SOP-8 package and requires very few external devices for operation.

TYPICAL APPLICATION CIRCUIT

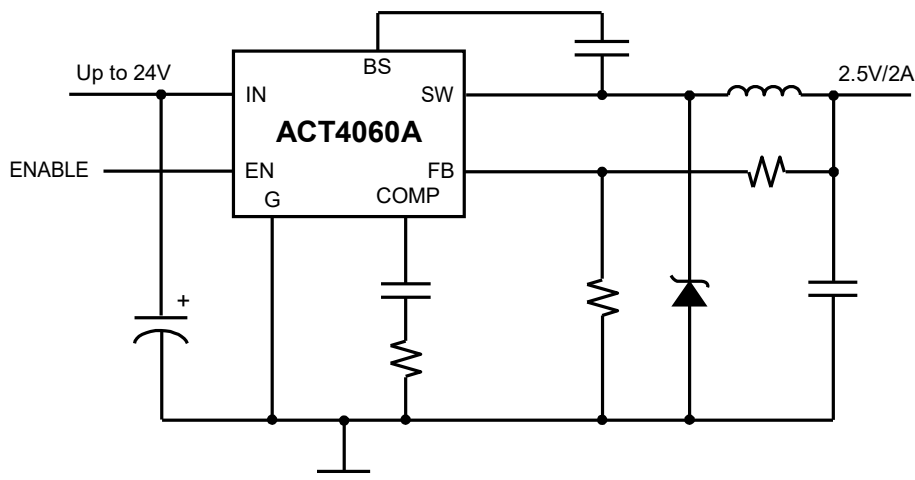

ORDERING INFORMATION

PART NUMBER	TEMPERATURE RANGE	PACKAGE	PINS	PACKING
ACT4060ASH	-40°C to 85°C	SOP-8	8	TUBE
ACT4060ASH-T	-40°C to 85°C	SOP-8	8	TAPE & REEL

PIN CONFIGURATION

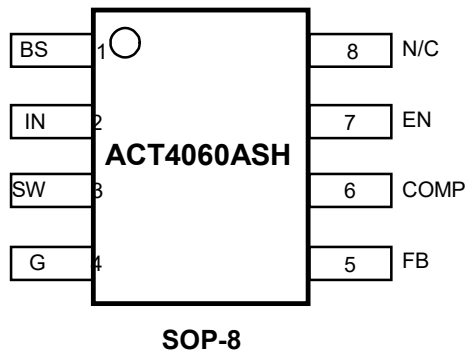

PIN DESCRIPTIONS

PIN	NAME	DESCRIPTION
1	BS	Bootstrap. This pin acts as the positive rail for the high-side switch's gate driver. Connect a 10nF capacitor between BS and SW.
2	IN	Input Supply. Bypass this pin to G with a low ESR capacitor. See <i>Input Capacitor</i> in the <i>Application Information</i> section.
3	SW	Switch Output. Connect this pin to the switching end of the inductor.
4	G	Ground.
5	FB	Feedback Input. The voltage at this pin is regulated to 1.293V. Connect to the resistor divider between output and ground to set output voltage.
6	COMP	Compensation Pin. See <i>Stability Compensation</i> in the <i>Application Information</i> section.
7	EN	Enable Input. When higher than 1.3V, this pin turns the IC on. When lower than 0.7V, this pin turns the IC off. Output voltage is discharged when the IC is off. When left unconnected, EN is pulled up to 4.5V with a 2μA pull-up current.
8	N/C	Not Connected.

ABSOLUTE MAXIMUM RATINGS^①

PARAMETER	VALUE	UNIT
IN Supply Voltage	-0.3 to 28	V
SW Voltage	-1 to $V_{IN} + 1$	V
BS Voltage	$V_{SW} - 0.3$ to $V_{SW} + 8$	V
EN, FB, COMP Voltage	-0.3 to 6	V
Continuous SW Current	Internally Limited	A
Junction to Ambient Thermal Resistance (θ_{JA})	105	°C/W
Maximum Power Dissipation	0.76	W
Operating Junction Temperature	-40 to 150	°C
Storage Temperature	-55 to 150	°C
Lead Temperature (Soldering, 10 sec)	300	°C

①: Do not exceed these limits to prevent damage to the device. Exposure to absolute maximum rating conditions for long periods may affect device reliability.

ELECTRICAL CHARACTERISTICS

($V_{IN} = 12V$, $T_A = 25^\circ C$, unless otherwise specified.)

PARAMETER	SYMBOL	TEST CONDITIONS	MIN	TYP	MAX	UNIT
Input Voltage	V_{IN}	$V_{OUT} = 3.3V$, $I_{LOAD} = 0A$ to $1A$	4.5		24	V
Feedback Voltage	V_{FB}	$4.5V \leq V_{IN} \leq 24V$, $V_{COMP} = 1.5V$	1.267	1.293	1.319	V
High-Side Switch On Resistance	R_{ONH}			0.18		Ω
Low-Side Switch On Resistance	R_{ONL}			4.5		Ω
SW Leakage		$V_{EN} = 0$		0	10	μA
Current Limit	I_{LIM}		2.4	2.85		A
COMP to Current Limit Transconductance	G_{COMP}	$V_{IN} = 12V$, $V_{OUT} = 5V$		1.8		A/V
Error Amplifier Transconductance	G_{EA}	$\Delta I_{COMP} = \pm 10\mu A$		650		$\mu A/V$
Error Amplifier DC Gain	A_{VEA}			4000		V/V
Switching Frequency	f_{SW}		350	400	450	kHz
Short Circuit Switching Frequency		$V_{FB} = 0$		60		kHz
Maximum Duty Cycle	D_{MAX}	$V_{FB} = 1.1V$		95		%
Minimum Duty Cycle		$V_{FB} = 1.4V$			0	%
Enable Threshold Voltage		Hysteresis = $0.1V$	0.7	1	1.3	V
Enable Pull-Up Current		Pin pulled up to $4.5V$ typically when left unconnected		2		μA
Supply Current in Shutdown		$V_{EN} = 0$		10	20	μA
IC Supply Current in Operation		$V_{EN} = 3V$, $V_{FB} = 1.4V$		0.55		mA
Thermal Shutdown Temperature		Hysteresis = $10^\circ C$		160		°C

FUNCTIONAL BLOCK DIAGRAM

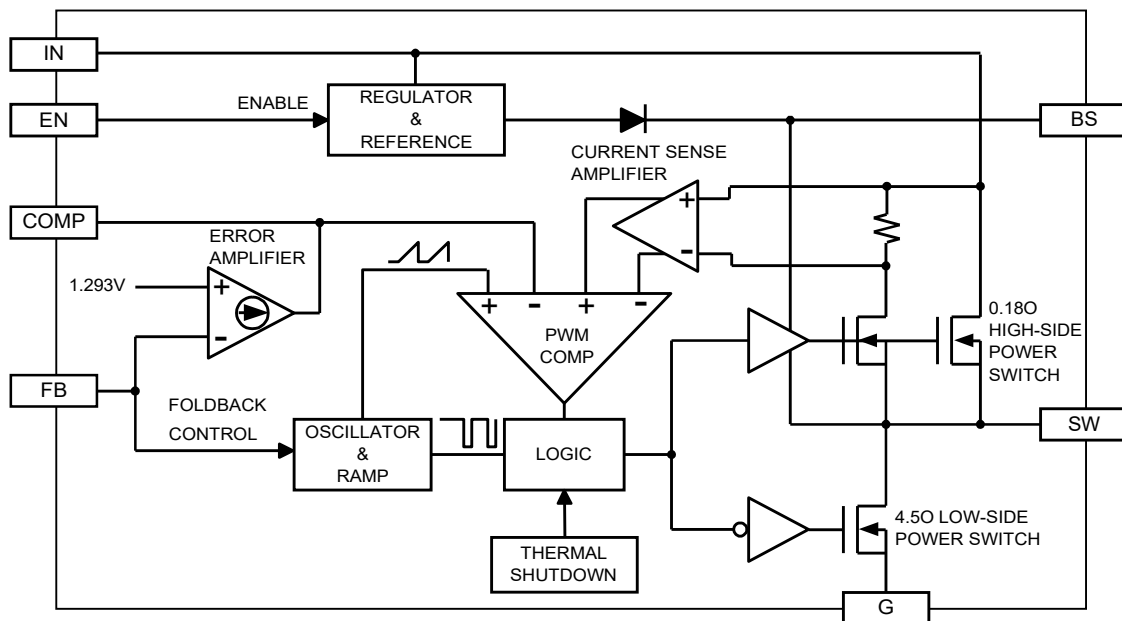

FUNCTIONAL DESCRIPTION

As seen in *Functional Block Diagram*, the ACT4060A is a current mode pulse width modulation (PWM) converter. The converter operates as follows:

A switching cycle starts when the rising edge of the Oscillator clock output causes the High-Side Power Switch to turn on and the Low-Side Power Switch to turn off. With the SW side of the inductor now connected to IN, the inductor current ramps up to store energy in the magnetic field. The inductor current level is measured by the Current Sense Amplifier and added to the Oscillator ramp signal. If the resulting summation is higher than the COMP voltage, the output of the PWM Comparator goes high. When this happens or when Oscillator clock output goes low, the High-Side Power Switch turns off and the Low-Side Power Switch turns on. At this point, the SW side of the inductor swings to a diode voltage below ground, causing the inductor current to decrease and magnetic energy to be transferred to output. This state continues until the cycle starts again.

The High-Side Power Switch is driven by logic using BS as the positive rail. This pin is charged to $V_{SW} + 6V$ when the Low-Side Power Switch turns on.

The COMP voltage is the integration of the error between FB input and the internal 1.293V

reference. If FB is lower than the reference voltage, COMP tends to go higher to increase current to the output. Current limit happens when COMP reaches its maximum clamp value of 2.55V.

The Oscillator normally switches at 400kHz. However, if FB voltage is less than 0.7V, then the switching frequency decreases until it reaches a typical value of 60kHz at $V_{FB} = 0.5V$.

Shutdown Control

The ACT4060A has an enable input EN for turning the IC on or off. When EN is less than 0.7V, the IC is in 10 μ A low current shutdown mode and output is discharged through the Low-Side Power Switch. When EN is higher than 1.3V, the IC is in normal operation mode. EN is internally pulled up with a 2 μ A current source and can be left unconnected for always-on operation. Note that EN is a low voltage input with a maximum voltage of 6V, it should never be directly connected to IN.

Thermal Shutdown

The ACT4060A automatically turns off when its junction temperature exceeds 160°C.

APPLICATIONS INFORMATION

Output Voltage Setting

Figure 1:

Output Voltage Setting

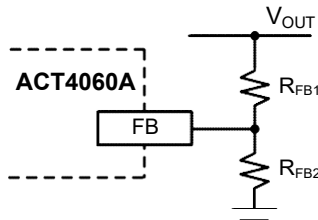

Figure 1 shows the connections for setting the output voltage. Select the proper ratio of the two feedback resistors R_{FB1} and R_{FB2} based on the output voltage. Typically, use $R_{FB2} \approx 10\text{k}\Omega$ and determine R_{FB1} from the following equation:

$$R_{FB1} = R_{FB2} \left(\frac{V_{OUT}}{1.293V} - 1 \right) \quad (1)$$

Inductor Selection

The inductor maintains a continuous current to the output load. This inductor current has a ripple that is dependent on the inductance value: higher inductance reduces the peak-to-peak ripple current. The trade off for high inductance value is the increase in inductor core size and series resistance,

and the reduction in current handling capability. In general, select an inductance value L based on ripple current requirement:

$$L = \frac{V_{OUT} \times (V_{IN} - V_{OUT})}{V_{IN} f_{SW} I_{OUTMAX} K_{RIPPLE}} \quad (2)$$

where V_{IN} is the input voltage, V_{OUT} is the output voltage, f_{SW} is the switching frequency, I_{OUTMAX} is the maximum output current, and K_{RIPPLE} is the ripple factor. Typically, choose $K_{RIPPLE} = 30\%$ to correspond to the peak-to-peak ripple current being 30% of the maximum output current.

With this inductor value, the peak inductor current is $I_{OUT} \times (1 + K_{RIPPLE}/2)$. Make sure that this peak inductor current is less than the 3A current limit. Finally, select the inductor core size so that it does not saturate at 3A. Typical inductor values for various output voltages are shown in Table 1.

Table 1:

Typical Inductor Values

V_{OUT}	1.5V	1.8V	2.5V	3.3V	5V
L	6.8 μH	6.8 μH	10 μH	15 μH	22 μH

Input Capacitor

The input capacitor needs to be carefully selected to maintain sufficiently low ripple at the supply input of the converter. A low ESR capacitor is highly recommended. Since large current flows in and out of this capacitor during switching, its ESR also affects efficiency.

The input capacitance needs to be higher than 10 μF . The best choice is the ceramic type, however, low ESR tantalum or electrolytic types may also be used provided that the RMS ripple current rating is higher than 50% of the output current. The input capacitor should be placed close to the IN and G pins of the IC, with the shortest traces possible. In the case of tantalum or electrolytic types, they can be further away if a small parallel 0.1 μF ceramic capacitor is placed right next to the IC.

Output Capacitor

The output capacitor also needs to have low ESR to keep low output voltage ripple. The output ripple voltage is:

$$V_{RIPPLE} = I_{OUTMAX} K_{RIPPLE} R_{ESR} + \frac{V_{IN}}{28 \times f_{SW}^2 LC_{OUT}} \quad (3)$$

where I_{OUTMAX} is the maximum output current, K_{RIPPLE} is the ripple factor, R_{ESR} is the ESR of the output capacitor, f_{SW} is the switching frequency, L is the inductor value, and C_{OUT} is the output capacitance. In the case of ceramic output capacitors, R_{ESR} is very small and does not contribute to the ripple. Therefore, a lower capacitance value can be used for ceramic type. In the case of tantalum or electrolytic capacitors, the ripple is dominated by R_{ESR} multiplied by the ripple current. In that case, the output capacitor is chosen to have sufficiently low ESR.

For ceramic output capacitor, typically choose a capacitance of about 22 μF . For tantalum or electrolytic capacitors, choose a capacitor with less than 50m Ω ESR.

Rectifier Diode

Use a Schottky diode as the rectifier to conduct current when the High-Side Power Switch is off. The Schottky diode must have current rating higher than the maximum output current and a reverse voltage rating higher than the maximum input voltage.

STABILITY COMPENSATION

Figure 2:

Stability Compensation

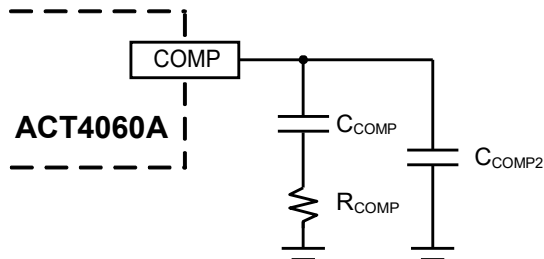

①: C_{COMP2} is needed only for high ESR output capacitor

The feedback loop of the IC is stabilized by the components at the COMP pin, as shown in Figure 2. The DC loop gain of the system is determined by the following equation:

$$A_{VDC} = \frac{1.3V}{I_{OUT}} A_{VEA} G_{COMP} \quad (4)$$

The dominant pole P1 is due to C_{COMP}:

$$f_{P1} = \frac{G_{EA}}{2\pi A_{VEA} C_{COMP}} \quad (5)$$

The second pole P2 is the output pole:

$$f_{P2} = \frac{I_{OUT}}{2\pi V_{OUT} C_{OUT}} \quad (6)$$

The first zero Z1 is due to R_{COMP} and C_{COMP}:

$$f_{Z1} = \frac{1}{2\pi R_{COMP} C_{COMP}} \quad (7)$$

And finally, the third pole is due to R_{COMP} and C_{COMP2} (if C_{COMP2} is used):

$$f_{P3} = \frac{1}{2\pi R_{COMP} C_{COMP2}} \quad (8)$$

The following steps should be used to compensate the IC:

STEP 1. Set the cross over frequency at 1/10 of the switching frequency via R_{COMP}:

$$R_{COMP} = \frac{2\pi V_{OUT} C_{OUT} f_{SW}}{10 G_{EA} G_{COMP} 1.3V} = 1.7 \times 10^8 V_{OUT} C_{OUT} \quad (\Omega) \quad (9)$$

but limit R_{COMP} to 15kΩ maximum.

STEP 2. Set the zero f_{Z1} at 1/4 of the cross over frequency. If R_{COMP} is less than 15kΩ, the equation for C_{COMP} is:

$$C_{COMP} = \frac{1.8 \times 10^{-5}}{R_{COMP}} \quad (F) \quad (10)$$

If R_{COMP} is limited to 15kΩ, then the actual cross over frequency is 3.4 / (V_{OUT}C_{OUT}). Therefore:

$$C_{COMP} = 1.2 \times 10^{-5} V_{OUT} C_{OUT} \quad (F) \quad (11)$$

STEP 3. If the output capacitor's ESR is high enough to cause a zero at lower than 4 times the cross over frequency, an additional compensation capacitor C_{COMP2} is required. The condition for using C_{COMP2} is:

$$R_{ESRCOUT} \geq \text{Min} \left(\frac{1.1 \times 10^{-6}}{C_{OUT}}, 0.012 \times V_{OUT} \right) \quad (\Omega) \quad (12)$$

And the proper value for C_{COMP2} is:

$$C_{COMP2} = \frac{C_{OUT} R_{ESRCOUT}}{R_{COMP}} \quad (13)$$

Though C_{COMP2} is unnecessary when the output capacitor has sufficiently low ESR, a small value C_{COMP2} such as 100pF may improve stability against PCB layout parasitic effects.

Table 2 shows some calculated results based on the compensation method above.

Table 2:

Typical Compensation for Different Output Voltages and Output Capacitors

V _{OUT}	C _{OUT}	R _{COMP}	C _{COMP}
2.5V	22μF Ceramic	8.2kΩ	2.2nF
3.3V	22μF Ceramic	12kΩ	1.5nF
5V	22μF Ceramic	15kΩ	1.5nF
2.5V	47μF SP CAP	15kΩ	1.5nF
3.3V	47μF SP CAP	15kΩ	1.8nF
5V	47μF SP CAP	15kΩ	2.7nF
2.5V	470μF/6.3V/30mΩ	15kΩ	15nF
3.3V	470μF/6.3V/30mΩ	15kΩ	22nF
5V	470μF/6.3V/30mΩ	15kΩ	27nF

Figure 4 shows an example ACT4060A application circuit generating a 3.3V/2A output.

ACT4060A PCB Layout Guidelines.

Place all the power components (Diode, Inductor, filter Capacitors) as close as possible. Use short and wide trace between them.

If double layer PCB is used, it is good if the bottom layer is almost fill as ground. Use ground planes for power ground and signal ground, connect signal ground and power ground at single point close to the IC GND.

Arrange the power components so that the switching current loop curl in the same direction.

Separate noise sensitive traces, such as the voltage feedback path, compensation from noisy sources such as inductor, diode, input capacitor.

Place components, such as compensation, feedback network and boost-trap capacitors, as close to the IC as possible.

Ceramic cap C1 is closely placed across V_{IN} and GND of the IC, as close as possible.

Figure 3:
ACT4060A PCB Layout Reference

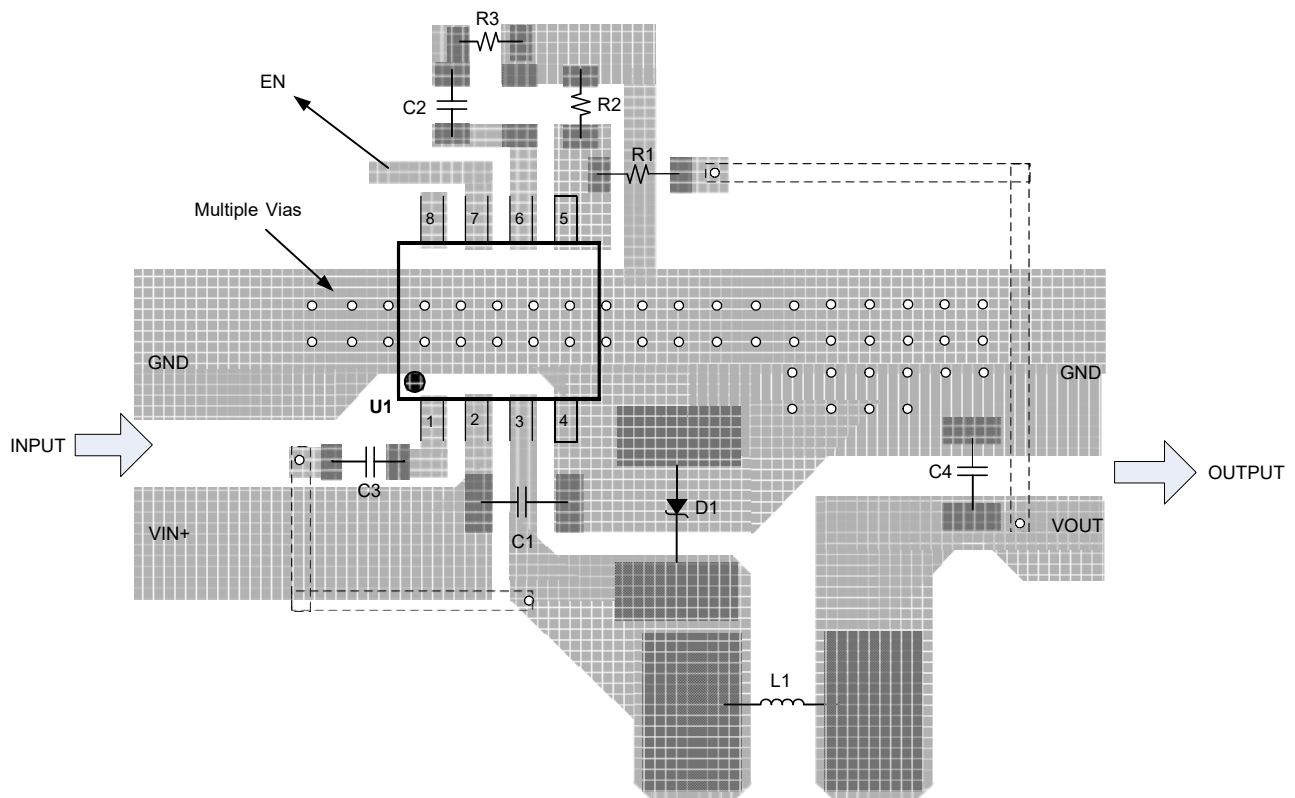
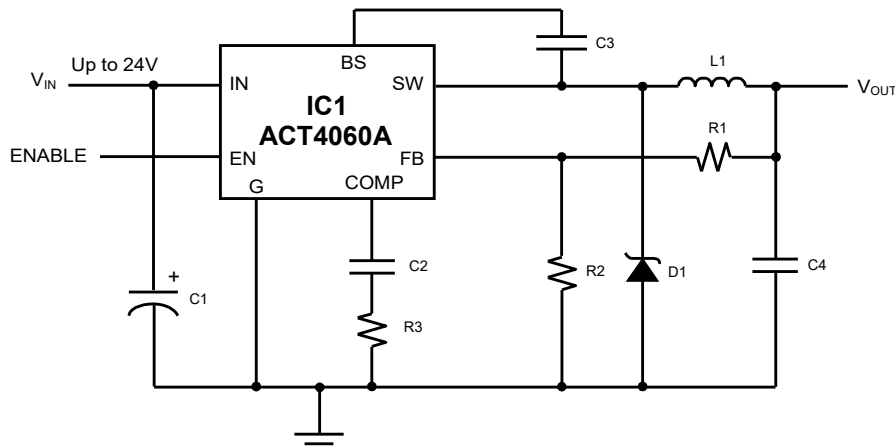

Figure 4:
ACT4060A 3.3V/2A Output Application^①



①: D1 is a 40V, 3A Schottky diode with low forward voltage, an IR 30BQ040 or SK34 equivalent. C4 can be either a ceramic capacitor (Panasonic ECJ-3YB1C226M) or SP-CAP (Specialty Polymer) Aluminum Electrolytic Capacitor such as Panasonic EEFC0J470XR. The SP-Cap is based on aluminum electrolytic capacitor technology, but uses a solid polymer electrolyte and has very stable capacitance characteristics in both operating temperature and frequency compared to ceramic, polymer, and low ESR tantalum capacitors.

Table 3:
ACT4060A Bill of Materials (Apply for 3.3V Output Application)

ITEM	DESCRIPTION	MANUFACTURER	QTY	REFERENCE
1	IC, ACT4060A	Active-Semi	1	U1
2	15 μ H \pm 20%, I _{SAT} = 2.7A, I _{DC} = 2.4A@ Δ T = 40°C	Taiyo Yuden NR 8040T 150M	1	L1
	15 μ H \pm 10%, I _{SAT} = 2.88A, I _{DC} = 2.47A@ Δ T = 40°C	Würth Elektronik 744776115		
	10 μ H \pm 20%, I _{SAT} = 3.4A, I _{DC} = 2.5A@ Δ T = 40°C	Taiyo Yuden NR 6045T 100M		
	10 μ H \pm 10%, I _{SAT} = 2.95A, I _{DC} = 2.3A@ Δ T = 40°C	Würth Elektronik 74477510		
3	Schottky Diode SK34/40V, 3A, SMB	Transys electronics	1	D1
	Schottky Diode B340C/40V, 3A, SMB	Diodes Inc	1	
4	Ceramic cap 10 μ F/35V, X7R, 1210	Murata, TDK, Taiyo Yuden	1	C1
5	Ceramic cap 2.2nF/6.3V, X7R, 0603	Murata, TDK, Taiyo Yuden	1	C2
6	Ceramic cap 10nF/50V, X7R, 0603	Murata, TDK, Taiyo Yuden	1	C3
7	Ceramic cap 22 μ F/10V, X7R, 1210	Murata, TDK, Taiyo Yuden	1	C4
	SP cap 47 μ F/6.3V, 50m Ω	Kemet, Panasonic		
8	Resistor, 15.5k Ω , 1/16W, 1%, 0603	FengHua, Neohm, Yageo	1	R1
9	Resistor, 10k Ω , 1/16W, 1%, 0603			R2
10	Resistor, 12k Ω , 1/16W, 5%, 0603			R3

Figure 5:
ACT4060A 5V/2A Output Application[Ⓞ]

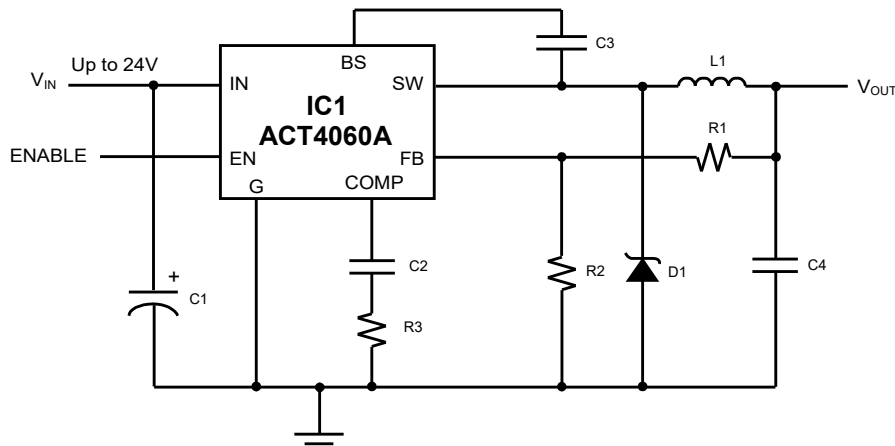

Ⓞ: D1 is a 40V, 3A Schottky diode with low forward voltage, an IR 30BQ040 or SK34 equivalent. C4 can be either a ceramic capacitor (Panasonic ECJ-3YB1C226M) or SP-CAP (Specialty Polymer) Aluminum Electrolytic Capacitor such as Panasonic EEFC0J470XR. The SP-Cap is based on aluminum electrolytic capacitor technology, but uses a solid polymer electrolyte and has very stable capacitance characteristics in both operating temperature and frequency compared to ceramic, polymer, and low ESR tantalum capacitors.

Table 4:
ACT4060A Bill of Materials (Apply for 5V Output Application)

ITEM	DESCRIPTION	MANUFACTURER	QTY	REFERENCE
1	IC, ACT4060A	Active-Semi	1	U1
2	15 μ H \pm 20%, I _{SAT} = 2.7A, I _{DC} = 2.4A@ Δ T = 40°C	Taiyo Yuden NR 8040T 150M	1	L1
	15 μ H \pm 10%, I _{SAT} = 2.88A, I _{DC} = 2.47A@ Δ T = 40°C	Würth Elektronik 744776115		
3	Schottky Diode SK34/40V, 3A, SMB	Transys electronics	1	D1
	Schottky Diode B340C/40V, 3A, SMB	Diodes Inc		
4	Ceramic cap 10 μ F/35V, X7R, 1210	Murata, TDK, Taiyo Yuden	1	C1
5	Ceramic cap 2.2nF/6.3V, X7R, 0603	Murata, TDK, Taiyo Yuden	1	C2
6	Ceramic cap 10nF/50V, X7R, 0603	Murata, TDK, Taiyo Yuden	1	C3
7	Ceramic cap 22 μ F/10V, X7R, 1210	Murata, TDK, Taiyo Yuden	1	C4
	SP cap 47 μ F/6.3V, 50m Ω	Kemet, Panasonic		
8	Resistor, 28.7k Ω , 1/16W, 1%, 0603	FengHua, Neohm, Yageo	1	R1
9	Resistor, 10k Ω , 1/16W, 1%, 0603			R2
10	Resistor, 15k Ω , 1/16W, 5%, 0603			R3

TYPICAL PERFORMANCE CHARACTERISTICS

(Circuit of Figure 4, unless otherwise specified.)

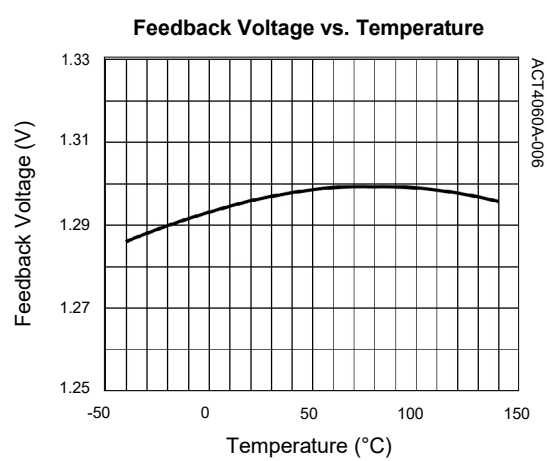
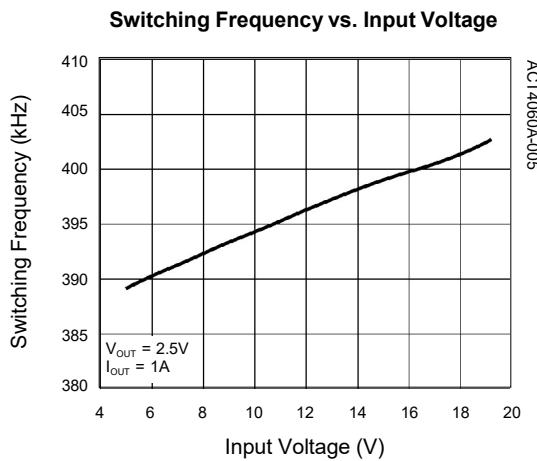
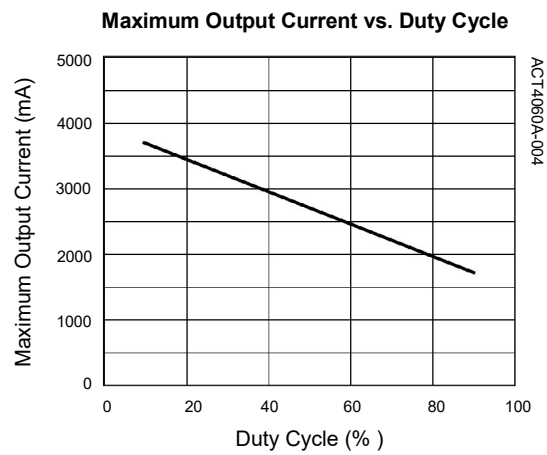
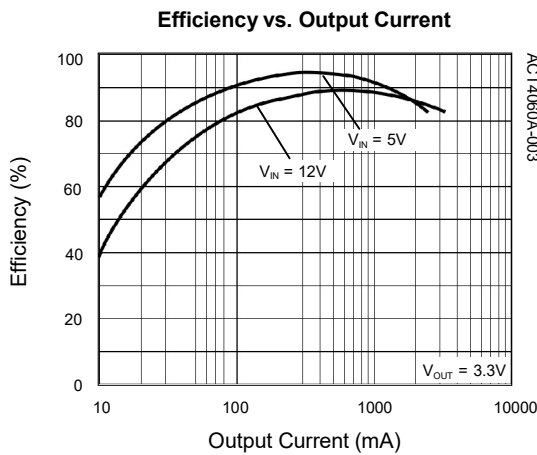
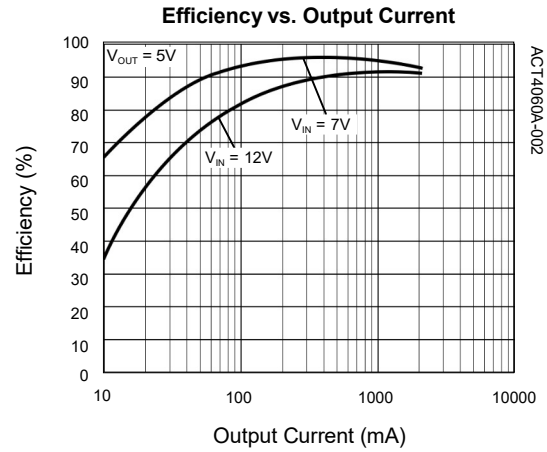
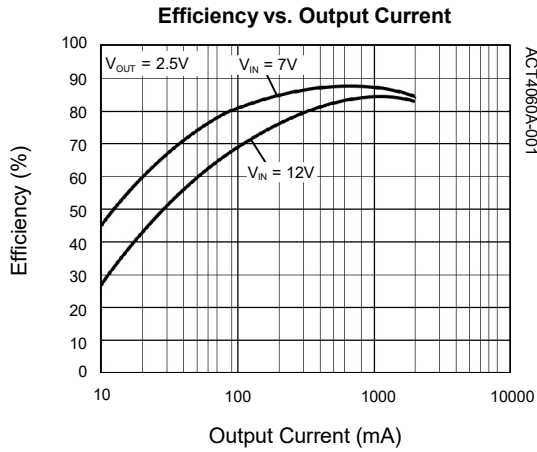

TYPICAL PERFORMANCE CHARACTERISTICS CONT'D

(Circuit of Figure 4, unless otherwise specified.)

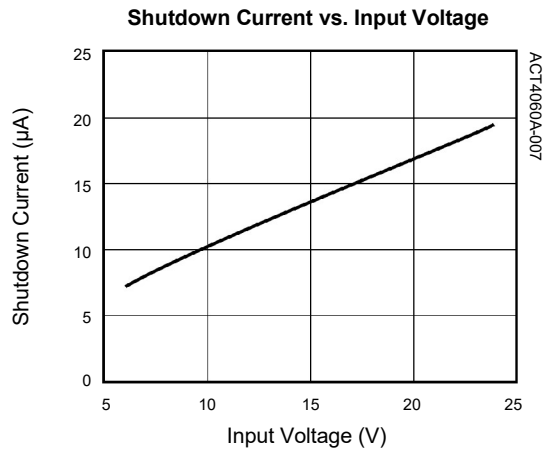

PACKAGE OUTLINE

SOP-8 PACKAGE OUTLINE AND DIMENSIONS

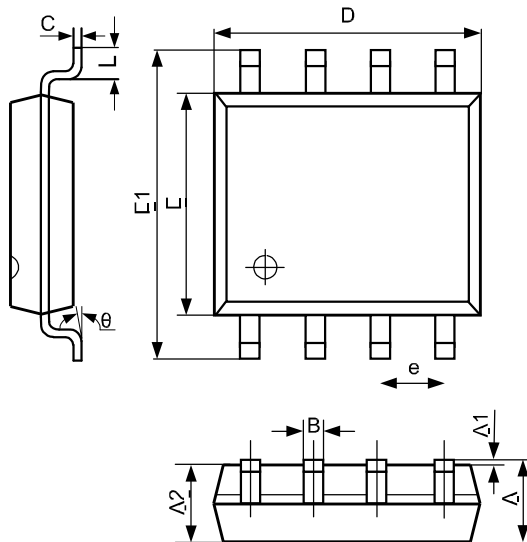

SYMBOL	DIMENSION IN MILLIMETERS		DIMENSION IN INCHES	
	MIN	MAX	MIN	MAX
A	1.350	1.750	0.053	0.069
A1	0.100	0.250	0.004	0.010
A2	1.350	1.550	0.053	0.061
B	0.330	0.510	0.013	0.020
C	0.190	0.250	0.007	0.010
D	4.700	5.100	0.185	0.201
E	3.800	4.000	0.150	0.157
E1	5.800	6.300	0.228	0.248
e	1.270 TYP		0.050 TYP	
L	0.400	1.270	0.016	0.050
theta	0°	8°	0°	8°

Active-Semi, Inc. reserves the right to modify the circuitry or specifications without notice. Users should evaluate each product to make sure that it is suitable for their applications. Active-Semi products are not intended or authorized for use as critical components in life-support devices or systems. Active-Semi, Inc. does not assume any liability arising out of the use of any product or circuit described in this datasheet, nor does it convey any patent license.

Active-Semi and its logo are trademarks of Active-Semi, Inc. For more information on this and other products, contact sales@active-semi.com or visit <http://www.active-semi.com>. For other inquiries, please send to:

2728 Orchard Parkway, San Jose, CA 95134-2012, USA



Компания «ЭлектроПласт» предлагает заключение долгосрочных отношений при поставках импортных электронных компонентов на взаимовыгодных условиях!

Наши преимущества:

- Оперативные поставки широкого спектра электронных компонентов отечественного и импортного производства напрямую от производителей и с крупнейших мировых складов;
- Поставка более 17-ти миллионов наименований электронных компонентов;
- Поставка сложных, дефицитных, либо снятых с производства позиций;
- Оперативные сроки поставки под заказ (от 5 рабочих дней);
- Экспресс доставка в любую точку России;
- Техническая поддержка проекта, помощь в подборе аналогов, поставка прототипов;
- Система менеджмента качества сертифицирована по Международному стандарту ISO 9001;
- Лицензия ФСБ на осуществление работ с использованием сведений, составляющих государственную тайну;
- Поставка специализированных компонентов (Xilinx, Altera, Analog Devices, Intersil, Interpoint, Microsemi, Aeroflex, Peregrine, Syfer, Eurofarad, Texas Instrument, Miteq, Cobham, E2V, MA-COM, Hittite, Mini-Circuits, General Dynamics и др.);

Помимо этого, одним из направлений компании «ЭлектроПласт» является направление «Источники питания». Мы предлагаем Вам помощь Конструкторского отдела:

- Подбор оптимального решения, техническое обоснование при выборе компонента;
- Подбор аналогов;
- Консультации по применению компонента;
- Поставка образцов и прототипов;
- Техническая поддержка проекта;
- Защита от снятия компонента с производства.



Как с нами связаться

Телефон: 8 (812) 309 58 32 (многоканальный)

Факс: 8 (812) 320-02-42

Электронная почта: org@eplast1.ru

Адрес: 198099, г. Санкт-Петербург, ул. Калинина, дом 2, корпус 4, литера А.