

## Preliminary Product Specification

### 100GHz Ultra-High Speed Balanced Photodetector

#### BPDV412xRy-WF-zz

#### PRODUCT FEATURES

- Ultra-high bandwidth of >100GHz
- Based on a waveguide-integrated photodetector chip
- Excellent uniformity of photodiodes
- Integrated termination
- C-band performance
- SMF-28 optical input
- Temperature: 0°C to +75°C
- Supply voltage: +3.5/-3.5 V
- F16 package with W1-connector®
- Available as dual-pair or quad-set
- Offered also as 90GHz version



#### APPLICATIONS

- Coherent Test & Measurement Systems
- Next Generation DWDM Networks
- Transmission Systems with >1Tb/s data-rate
- Research and Development
- Detection of up to 160 Gbaud x-QAM signals

The BPDV412x balanced photodetector is a compact module consisting of two optimized 100 GHz waveguide-integrated photodiodes on a single chip. As a single device, this configuration ensures excellent uniformity of the paired photodiodes performance; biasing is achieved via an integrated biasing network. Due to the optimized design of waveguide and Photodiode, even at high optical power, a linear frequency response can be guaranteed. The integrated termination allows an excellent match of the electrical output signal. Custom configurations are available, such as BPDV matched pairs, and quad sets, including connector customization and fiber matching to enable coherent detection. A 90 GHz version of this module is also available upon request.

### I Ordering Information

**BPDV412xRy-WF-zz**

- x:     0: f3dB > 90 GHz  
       1: f3dB > 100 GHz
  
- Ry:    R = single balanced detector  
       RM = matched pair of balanced detectors  
       RQ = matched quad-set of balanced detectors
  
- zz:    SA = SC/APC  
       other options upon request

### II Block Diagram

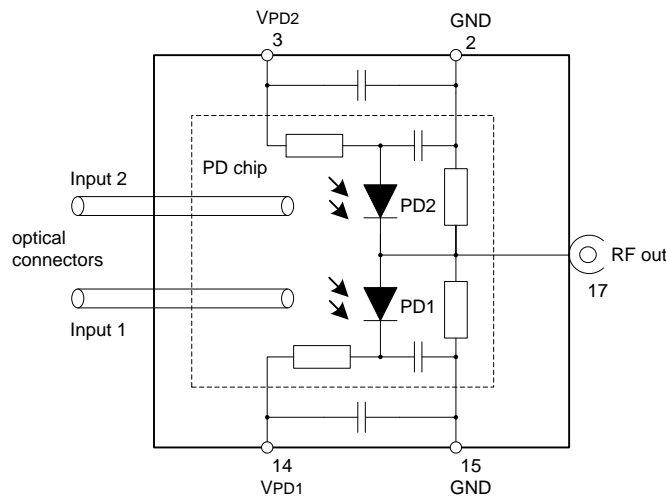

Figure 1 Block Diagram of BPDV412xRy-WF-zz

### III Absolute Maximum Ratings

Parameter	Symbol	Condition	Min.	Typ.	Max.	Unit
Photodiode bias voltage	$V_{PD1}$		0		4	V
	$V_{PD2}$		-4		0	
Maximum average optical input power	$P_{OPT}$	continuous wave (CW)			16	dBm
Electro static discharge	$V_{ESD}$	C=100 pF, R= 1.5 kΩ HBM	-250		250	V

## IV Environmental Conditions

Parameter	Symbol	Condition	Min.	Typ.	Max.	Unit
Storage temperature	T <sub>storage</sub>	non condensing	-40		+85	°C
Operating case temperature range	T <sub>CASE</sub>		0		+75	°C
Relative humidity range	RH	non condensing	5		85	%

## V Operating Conditions

Parameter	Symbol	Condition	Min.	Typ.	Max.	Unit
Operating wavelength range	$\lambda$		1525		1570	nm
Average optical input power range	P <sub>OPT</sub>				13	dBm
Photodiode bias voltage	V <sub>PD1</sub> V <sub>PD2</sub>		2.5 -3.8	3.3 -3.3	3.8 -2.5	V

## VI Electro-Optical Specifications<sup>1</sup>

Parameter	Symbol	Condition	Min.	Typ.	Max.	Unit
Photodiode DC responsivity	R	optimum polarization	0.23	0.27		A/W
Imbalance of responsivity	Imb	$Imb =  10 \cdot \log_{10}(R_{PD1}/R_{PD2}) $		0.15	0.5	
Polarization dependent loss	PDL			0.75	0.95	dB
Optical return loss	ORL		27			dB
3dB cut-off frequency (BPDV4121)	f <sub>3dB</sub>		100	105		GHz
3dB cut-off frequency (BPDV4120)	f <sub>3dB</sub>		90	95		GHz
Output Reflection Coefficient	S <sub>22</sub>	0...35 GHz		-10	-9	dB
		35...50 GHz		-8	-7	
		50...67 GHz		-5	-4.0	
CMRR		$CMRR = 20 \cdot \log_{10}  (S_{21} - S_{31}) / (S_{21} + S_{31}) $ 0...67 GHz		14		dB
Photodiode dark current	I <sub>dark</sub>			10	200	nA
Skew				1.0		ps
Skew (inter module)				4		ps
Notes:						
1 $\lambda = 1550$ nm, V <sub>PD</sub> = ± 3.3 V, T = 25°C, P <sub>OPT</sub> = +3 dBm						

## VII Typical Performance

Frequency response

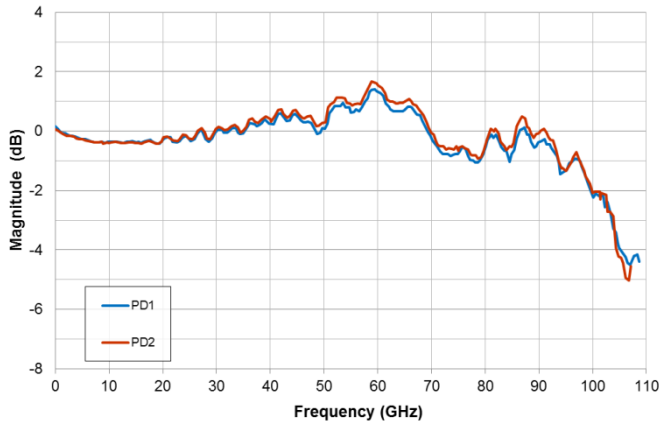

Figure 2 Frequency response of the BPDV4121R measured with Heterodyne measurement setup

## VIII Mechanical Specifications

All dimensions are in mm.

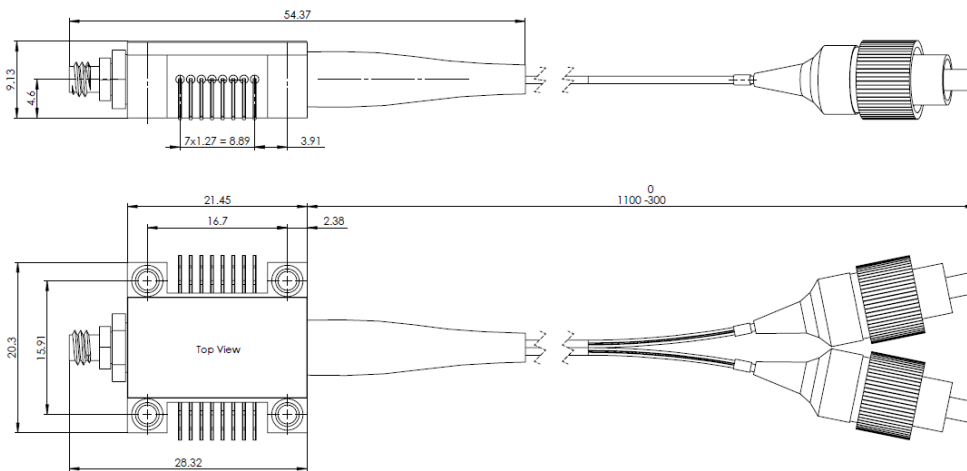

Figure 3. Mechanical dimensions of BPDV412xRy-WF-zz

## IX General Notices



### Notice

Stresses greater than those listed under “Absolute Maximum Ratings” may cause permanent damage to the device. This is a stress rating only and functional operation of the device at these or any other conditions above those indicated in the operations section for extended periods of time may affect reliability.

The inherent design of this component causes it to be sensitive to electrostatic discharge (ESD). To prevent ESD-induced damage and/or degradation to equipment, take normal ESD precautions when handling this product

## X Notes

Any trademarks used in this document are properties of their respective owners. Finisar Corporation reserves the right to make changes without notice.

## XI Revision History

Document Number: **TBD**

Revision	Date	Description
A1	2017-03-10	Initial Release.
A2	2017-03-17	Updated specifications

## XII For More Information

Finisar Corporation  
 1389 Moffett Park Drive  
 Sunnyvale, CA 94089-1133  
 Tel: +1-408-548-1000  
 Fax: +1-408-541-6138  
[high-speed-detectors@finisar.com](mailto:high-speed-detectors@finisar.com)  
[sales@finisar.com](mailto:sales@finisar.com)  
[www.finisar.com](http://www.finisar.com)



Компания «ЭлектроПласт» предлагает заключение долгосрочных отношений при поставках импортных электронных компонентов на взаимовыгодных условиях!

Наши преимущества:

- Оперативные поставки широкого спектра электронных компонентов отечественного и импортного производства напрямую от производителей и с крупнейших мировых складов;
- Поставка более 17-ти миллионов наименований электронных компонентов;
- Поставка сложных, дефицитных, либо снятых с производства позиций;
- Оперативные сроки поставки под заказ (от 5 рабочих дней);
- Экспресс доставка в любую точку России;
- Техническая поддержка проекта, помощь в подборе аналогов, поставка прототипов;
- Система менеджмента качества сертифицирована по Международному стандарту ISO 9001;
- Лицензия ФСБ на осуществление работ с использованием сведений, составляющих государственную тайну;
- Поставка специализированных компонентов (Xilinx, Altera, Analog Devices, Intersil, Interpoint, Microsemi, Aeroflex, Peregrine, Syfer, Eurofarad, Texas Instrument, Miteq, Cobham, E2V, MA-COM, Hittite, Mini-Circuits, General Dynamics и др.);

Помимо этого, одним из направлений компании «ЭлектроПласт» является направление «Источники питания». Мы предлагаем Вам помощь Конструкторского отдела:

- Подбор оптимального решения, техническое обоснование при выборе компонента;
- Подбор аналогов;
- Консультации по применению компонента;
- Поставка образцов и прототипов;
- Техническая поддержка проекта;
- Защита от снятия компонента с производства.



#### Как с нами связаться

**Телефон:** 8 (812) 309 58 32 (многоканальный)

**Факс:** 8 (812) 320-02-42

**Электронная почта:** [org@eplast1.ru](mailto:org@eplast1.ru)

**Адрес:** 198099, г. Санкт-Петербург, ул. Калинина, дом 2, корпус 4, литера А.