

TPC-1282T

12.1" XGA TFT LED LCD Touch Panel Computer with 5th Gen. Intel® Core™ i3 Processor



Features

- Industrial-grade 12.1" XGA TFT LCD with 50K lifetime and LED backlight
- 5th Gen Intel® Core™ i3-5010U with 4 GB DDR3L SDRAM
- Compact, fanless embedded system with aluminum alloy front bezel
- True-flat, IP65-rated front panel
- Durable touchscreen with 5-wire resistive touch control
- Supports expansion via PCIe 1x and mini PCIe
- Diverse system I/O and isolated digital I/O via iDoor technology
- Supports fieldbus protocols via iDoor technology
- 3G/GPS/GPRS/Wi-Fi capabilities via iDoor technology
- Supports MRAM via iDoor technology
- Chassis grounding protection
- Supports HDMI and multimedia audio
- Supports Advantech's SNMP Subagent software
- Supports Advantech's WISE-PaaS/RMM remote management software

Introduction

The TPC-1282H touch panel computer is equipped with a 12.1" XGA TFT LCD, low-power 5th Gen Intel® Core™ i3-5010U 2.10 GHz processor, and 4 GB DDR3L SDRAM to deliver high-performance computing in a compact, fanless system. To enhance the system's durability, TPC-1282H features an IP66-rated front panel that protects against dust and water ingress, a die-cast aluminum alloy front bezel, and 5-wire resistive touch control. TPC-1282H also includes PCIe and mini PCIe slots to extend the system functionalities and satisfy diverse automation application needs. Moreover, Advantech's iDoor technology can be integrated via the mini PCIe slot in order to provide additional I/O connectors, isolated digital I/O, fieldbus protocols, 3G/GPS/GPRS/Wi-Fi communication, and MRAM. The integrated HDMI and audio ports allow a secondary monitor and speakers to be attached for increased functionality.

Specifications

General

- BIOS** AMI UEFI
- Certification** BSMI, CCC, CE, FCC Class A, UL
- Cooling System** Fanless design
- Dimensions (W x H x D)** 311.8 x 238 x 77.2 mm (12.28 x 9.38 x 3.04 in)
- Enclosure** Front bezel: Die cast aluminum alloy
Back housing: PC/ABS resin
- Mounting** Desktop, Wall or Panel Mount
- OS Support** Microsoft® WES7 (32/64-bit), Windows 7 (32/64-bit), Windows Embedded 8.1 Industry Pro (64-bit), Windows 10 IoT Enterprise LTSC
- Power Consumption** 19W typical, 60W max. (without add-on card)
- Power Input** 24V_{DC} ± 20%
- Watchdog Timer** 1 ~ 255 sec (system)
- Weight (Net)** 3.2 kg (7.02 lbs)

System Hardware

- CPU** 5th Generation Intel Core i3-5010U 2.10 GHz
- Chipset** WildcatPoint-LP
- Memory** 4 GB DDR3L 1600 MHz SODIMM SDRAM
- LAN** 10/100/1000BASE-T x 2
- Expansion Slots** Half-size PCIe and full-size mini PCIe
- Storage** 1 x CFast
1 x 2.5" SATA SSD
1 x mSATA (via mini PCIe)
- I/O** 1 x RS-232, 1 x RS-232/422/485
2 x USB 3.0, 1 x HDMI 1.4
1 x Audio line out, 1 x USB 2.0 (optional)
1 x Audio mic in (optional)

LCD Display

- Display Type** XGA TFT LED LCD
- Display Size** 12.1"
- Max. Resolution** 1024 x 768
- Max. Colors** 16.2M

- Luminance cd/m²** 600
- Viewing Angle (H/V°)** 160/140
- Backlight Life** 50,000 hr
- Contrast Ratio** 700:1

Touchscreen

- Lifespan** 36 million touches at single point
- Light Transmission** 81 ± 3%
- Resolution** Linearity
- Type** 5-wire analog resistive

Environment

- Humidity** 10 ~ 95% RH @ 40°C, non-condensing
- Ingress Protection** Front panel: IP66
- Operating Temperature** 0 ~ 50 °C (32 ~ 122 °F)
- Storage Temperature** -20 ~ 60 °C (-4 ~ 140 °F)
- Vibration Protection** With HDD: 1 Grms (5 ~ 500 Hz)
(Operating, random vibration)

Rear View

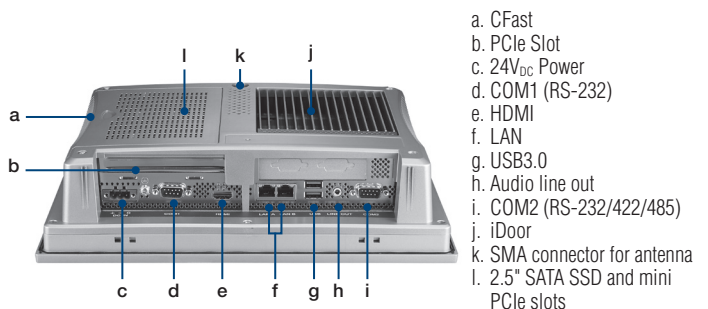

- a. CFast
- b. PCIe Slot
- c. 24V_{DC} Power
- d. COM1 (RS-232)
- e. HDMI
- f. LAN
- g. USB3.0
- h. Audio line out
- i. COM2 (RS-232/422/485)
- j. iDoor
- k. SMA connector for antenna
- l. 2.5" SATA SSD and mini PCIe slots

Dimensions

Unit: mm

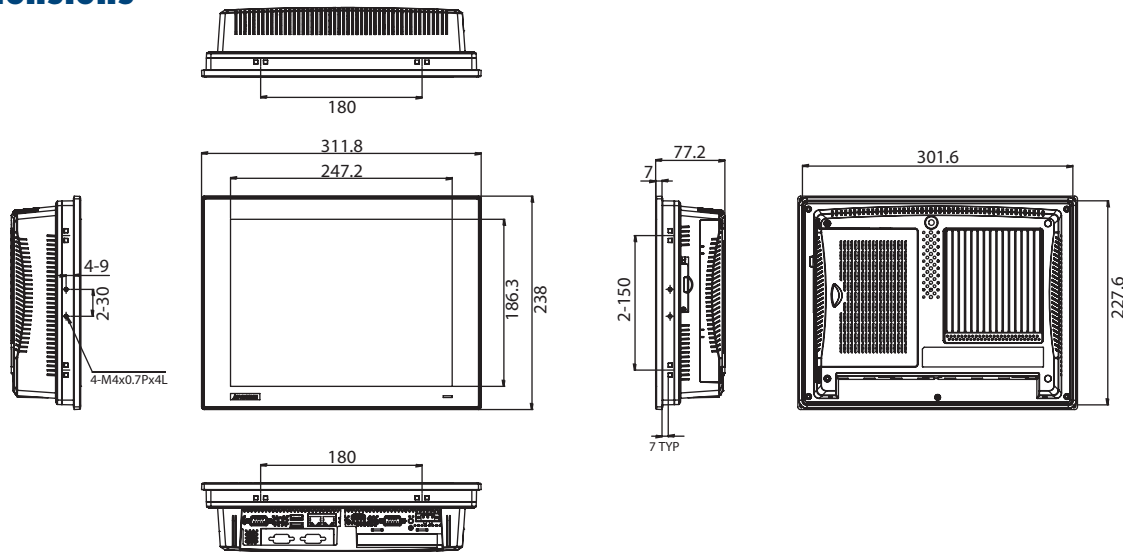

Panel Cutout Dimensions: 303 x 229 mm (11.93 x 9.02 in)

Ordering Information

- TPC-1282T-533AE 12.1" XGA Panel PC, Intel i3-50101U, 4GB, iDoor, PCIe

Optional Accessories

- 96PSA-A150W24T2 Adapter 100-240V 150W 24V
- 1702002600 Power Cable US Plug 1.8 M
- 1702002605 Power Cable EU Plug 1.8 M
- 1702031801 Power Cable UK Plug 1.8 M
- 1700000596-11 Power Cable China/Australia Plug 1.8 M
- TPC-1000H-WMKE TPC VESA Mounting Kit from 10" to 17" TPC
- TPC-1000H-SMKE TPC Stand kit from 10" to 17" TPC
- EWM-W151H01E 802.11bgn RTL8188EE 1T1R, Half-size Mini-PCIe (also need 9656EWMG00E)
- 9656EWMG00E Half-size miniPCIe to Full-size miniPCIe bracket set
- 1750000318 EMI Antenna 2DBI 2.4GHz SMA CONN for ARK-3384
- 1750003222 802.11b/g 5dBi Dipole Antenna
- 1750003418 Wireless Antenna AN2400-5901RS R/P SMA.M9dB

Embedded OS

- 2070013700 WS7P x86 V4.12 B001 MUI for TPC-1282T
- 2070015290 WS7P x64 V4.17 B001 MUI for TPC-1282T

iDoor Modules

- PCM-24D2R4-AE 2-Port Isolated RS-422/485 mPCIe, DB9
- PCM-27D24DI-AE 24-Channel Isolated Digital I/O w/ counter mPCIe, DB37
- PCM-26D2CA-AE 2-Port Isolated CANBus mPCIe, CANOpen, DB9
- PCM-24R1TP-AE 1-Port Gigabit Ethernet, Intel® 82574L, mPCIe, RJ45
- PCM-24S2WF-AE WiFi 802.11 a/b/g/n 2T2R w/ Bluetooth4.0, Half-size mPCIe, 2-port SMAPCM-26R2PN-MAE 2-Port Hilscher netX100 FieldBus mPCIe, PROFINET, RJ45, Master

- PCM-26R2EC-MAE 2-Port Hilscher netX100 FieldBus mPCIe, EtherCAT, RJ45, Master
- PCM-26R2EI-MAE 2-Port Hilscher netX100 FieldBus mPCIe, EtherNet/IP, RJ45, Master
- PCM-26R2S3-MAE 2-Port Hilscher netX100 FieldBus mPCIe, Sercos III, RJ45, Master

Application Software

<p>WebAccess/SCADA</p>	<p>Advantech WebAccess/SCADA is a 100% browser-based IIoT software platform aimed at supervisory control and data acquisition (SCADA) operations. WebAccess/SCADA provides open interfaces that allow our customers and partners to develop unique IIoT applications for different vertical markets. In addition to supporting traditional SCADA functions, the platform features an HTML5-based user interface and intelligent dashboard to facilitate cross-platform, cross-browser data analysis. Moreover, WebAccess/SCADA not only offers built-in widgets, but is also equipped with an innovative Widget Builder that enables customers to build their own widgets.</p>
<p>WebAccess/HMI</p>	<p>Advantech WebAccess/HMI is human-machine interface (HMI) software based on Microsoft's Windows operating system. This software features excellent communication and monitoring capabilities, supports more than 350 PLC communication protocols, and offers a wide choice of screen design objects to satisfy diverse integrations of factory automation and HMI operation and monitoring requirements.</p>
<p> CODESYS</p>	<p>The CODESYS application-ready-package offering includes a PC-based panel controller with multi-touch control, high-performance Intel Core i multi-core processor, SSD, 2 MB MRAM, Microsoft Windows Embedded 7 Pro OS, and CODESYS Control Runtime & Visualization software. This package allows users to easily develop a PC-based real-time control system, enables real-time PLC or PLC/SoftMotion control with flexible fieldbus options such as PROFINET, EtherCAT, EtherNet/IP, CANOpen, and Modbus TCP/RTU, and facilitates on-site visualized HMI operation. The software/hardware flexibility and the stability of a PC-based cabinet controller are suitable for various control applications in vertical industries.</p>



Компания «ЭлектроПласт» предлагает заключение долгосрочных отношений при поставках импортных электронных компонентов на взаимовыгодных условиях!

Наши преимущества:

- Оперативные поставки широкого спектра электронных компонентов отечественного и импортного производства напрямую от производителей и с крупнейших мировых складов;
- Поставка более 17-ти миллионов наименований электронных компонентов;
- Поставка сложных, дефицитных, либо снятых с производства позиций;
- Оперативные сроки поставки под заказ (от 5 рабочих дней);
- Экспресс доставка в любую точку России;
- Техническая поддержка проекта, помощь в подборе аналогов, поставка прототипов;
- Система менеджмента качества сертифицирована по Международному стандарту ISO 9001;
- Лицензия ФСБ на осуществление работ с использованием сведений, составляющих государственную тайну;
- Поставка специализированных компонентов (Xilinx, Altera, Analog Devices, Intersil, Interpoint, Microsemi, Aeroflex, Peregrine, Syfer, Eurofarad, Texas Instrument, Miteq, Cobham, E2V, MA-COM, Hittite, Mini-Circuits, General Dynamics и др.);

Помимо этого, одним из направлений компании «ЭлектроПласт» является направление «Источники питания». Мы предлагаем Вам помощь Конструкторского отдела:

- Подбор оптимального решения, техническое обоснование при выборе компонента;
- Подбор аналогов;
- Консультации по применению компонента;
- Поставка образцов и прототипов;
- Техническая поддержка проекта;
- Защита от снятия компонента с производства.



Как с нами связаться

Телефон: 8 (812) 309 58 32 (многоканальный)

Факс: 8 (812) 320-02-42

Электронная почта: org@eplast1.ru

Адрес: 198099, г. Санкт-Петербург, ул. Калинина, дом 2, корпус 4, литера А.