



MICROCHIP

MCP3912
ADC Evaluation Board
for 16-Bit MCUs
User's Guide

Note the following details of the code protection feature on Microchip devices:

- Microchip products meet the specification contained in their particular Microchip Data Sheet.
- Microchip believes that its family of products is one of the most secure families of its kind on the market today, when used in the intended manner and under normal conditions.
- There are dishonest and possibly illegal methods used to breach the code protection feature. All of these methods, to our knowledge, require using the Microchip products in a manner outside the operating specifications contained in Microchip's Data Sheets. Most likely, the person doing so is engaged in theft of intellectual property.
- Microchip is willing to work with the customer who is concerned about the integrity of their code.
- Neither Microchip nor any other semiconductor manufacturer can guarantee the security of their code. Code protection does not mean that we are guaranteeing the product as "unbreakable."

Code protection is constantly evolving. We at Microchip are committed to continuously improving the code protection features of our products. Attempts to break Microchip's code protection feature may be a violation of the Digital Millennium Copyright Act. If such acts allow unauthorized access to your software or other copyrighted work, you may have a right to sue for relief under that Act.

Information contained in this publication regarding device applications and the like is provided only for your convenience and may be superseded by updates. It is your responsibility to ensure that your application meets with your specifications. MICROCHIP MAKES NO REPRESENTATIONS OR WARRANTIES OF ANY KIND WHETHER EXPRESS OR IMPLIED, WRITTEN OR ORAL, STATUTORY OR OTHERWISE, RELATED TO THE INFORMATION, INCLUDING BUT NOT LIMITED TO ITS CONDITION, QUALITY, PERFORMANCE, MERCHANTABILITY OR FITNESS FOR PURPOSE. Microchip disclaims all liability arising from this information and its use. Use of Microchip devices in life support and/or safety applications is entirely at the buyer's risk, and the buyer agrees to defend, indemnify and hold harmless Microchip from any and all damages, claims, suits, or expenses resulting from such use. No licenses are conveyed, implicitly or otherwise, under any Microchip intellectual property rights.

Trademarks

The Microchip name and logo, the Microchip logo, dsPIC, FlashFlex, flexPWR, JukeBlox, KEELOQ, KEELOQ logo, Kleer, LANCheck, MediaLB, MOST, MOST logo, MPLAB, OptoLyzer, PIC, PICSTART, PIC³² logo, RightTouch, SpyNIC, SST, SST Logo, SuperFlash and UNI/O are registered trademarks of Microchip Technology Incorporated in the U.S.A. and other countries.

The Embedded Control Solutions Company and mTouch are registered trademarks of Microchip Technology Incorporated in the U.S.A.

Analog-for-the-Digital Age, BodyCom, chipKIT, chipKIT logo, CodeGuard, dsPICDEM, dsPICDEM.net, ECAN, In-Circuit Serial Programming, ICSP, Inter-Chip Connectivity, KleerNet, KleerNet logo, MiWi, MPASM, MPF, MPLAB Certified logo, MPLIB, MPLINK, MultiTRAK, NetDetach, Omniscient Code Generation, PICDEM, PICDEM.net, PICkit, PICtail, RightTouch logo, REAL ICE, SQI, Serial Quad I/O, Total Endurance, TSHARC, USBCheck, VariSense, ViewSpan, WiperLock, Wireless DNA, and ZENA are trademarks of Microchip Technology Incorporated in the U.S.A. and other countries.

SQTP is a service mark of Microchip Technology Incorporated in the U.S.A.

Silicon Storage Technology is a registered trademark of Microchip Technology Inc. in other countries.

GestIC is a registered trademarks of Microchip Technology Germany II GmbH & Co. KG, a subsidiary of Microchip Technology Inc., in other countries.

All other trademarks mentioned herein are property of their respective companies.

© 2014, Microchip Technology Incorporated, Printed in the U.S.A., All Rights Reserved.

ISBN: 978-1-63276-637-3

**QUALITY MANAGEMENT SYSTEM
CERTIFIED BY DNV
= ISO/TS 16949 =**

Microchip received ISO/TS-16949:2009 certification for its worldwide headquarters, design and wafer fabrication facilities in Chandler and Tempe, Arizona; Gresham, Oregon and design centers in California and India. The Company's quality system processes and procedures are for its PIC[®] MCUs and dsPIC[®] DSCs, KEELOQ[®] code hopping devices, Serial EEPROMs, microperipherals, nonvolatile memory and analog products. In addition, Microchip's quality system for the design and manufacture of development systems is ISO 9001:2000 certified.

Object of Declaration: MCP3912 ADC Evaluation Board for 16-Bit MCUs

EU Declaration of Conformity

Manufacturer: Microchip Technology Inc.
2355 W. Chandler Blvd.
Chandler, Arizona, 85224-6199
USA

This declaration of conformity is issued by the manufacturer.

The development/evaluation tool is designed to be used for research and development in a laboratory environment. This development/evaluation tool is not intended to be a finished appliance, nor is it intended for incorporation into finished appliances that are made commercially available as single functional units to end users. This development/evaluation tool complies with EU EMC Directive 2004/108/EC and as supported by the European Commission's Guide for the EMC Directive 2004/108/EC (8th February 2010).

This development/evaluation tool complies with EU RoHS2 Directive 2011/65/EU.

This development/evaluation tool, when incorporating wireless and radio-telecom functionality, is in compliance with the essential requirement and other relevant provisions of the R&TTE Directive 1999/5/EC and the FCC rules as stated in the declaration of conformity provided in the module datasheet and the module product page available at www.microchip.com.

For information regarding the exclusive, limited warranties applicable to Microchip products, please see Microchip's standard terms and conditions of sale, which are printed on our sales documentation and available at www.microchip.com.

Signed for and on behalf of Microchip Technology Inc. at Chandler, Arizona, USA

Derek Carlson
VP Development Tools

12-Sep-14
Date



MCP3912 ADC EVALUATION BOARD FOR 16-BIT MCUs USER'S GUIDE

Table of Contents

Preface	5
Introduction.....	5
Document Layout	5
Conventions Used in this Guide	6
Recommended Reading.....	7
The Microchip Web Site	7
Customer Support	7
Document Revision History	7
Chapter 1. Product Overview	
1.1 Overview	8
1.2 What the MCP3912 ADC Evaluation Board for 16-Bit MCUs Contains	9
Chapter 2. Hardware Description	
2.1 PIM Module/MCP3912 Connection and Peripheral Usage Overview	10
2.2 Analog Input Structure	11
2.3 Universal Serial Bus (USB)	12
Chapter 3. Firmware	
3.1 PIC24FJ256GA110 Firmware Description	13
3.2 Data Acquisition	13
3.3 UART Communication Protocol	14
Appendix A. Schematics and Layouts	
A.1 Introduction	15
A.2 Board – Power Schematic	16
A.3 Board – ADC Schematic	17
A.4 Board – Microcontroller (MCU) Schematic	18
A.5 Board – PIM Module Schematic	19
A.6 Board – Top Silk	20
A.7 Board – Top Copper and Silk	20
A.8 Board – Top Copper	21
A.9 Board – Internal Plane 1 and Assembly Top	22
A.10 Board – Internal Plane 2 and Assembly Top	22
A.11 Board – Bottom Copper	23
A.12 Board – Bottom Copper and SILK	23
A.13 Board – Bottom Silk	24
Appendix B. Bill of Materials (BOM)	
Worldwide Sales and Service	28



MCP3912 ADC EVALUATION BOARD FOR 16-BIT MCUs USER'S GUIDE

Preface

NOTICE TO CUSTOMERS

All documentation becomes dated, and this manual is no exception. Microchip tools and documentation are constantly evolving to meet customer needs, so some actual dialogs and/or tool descriptions may differ from those in this document. Please refer to our web site (www.microchip.com) to obtain the latest documentation available.

Documents are identified with a “DS” number. This number is located on the bottom of each page, in front of the page number. The numbering convention for the DS number is “DSXXXXXXXXA”, where “XXXXXXXX” is the document number and “A” is the revision level of the document.

For the most up-to-date information on development tools, see the MPLAB® IDE online help. Select the Help menu, and then Topics to open a list of available online help files.

INTRODUCTION

This chapter contains general information that will be useful to know before using the MCP3912 ADC Evaluation Board for 16-Bit MCUs. Items discussed in this chapter include:

- Document Layout
- Conventions Used in this Guide
- Recommended Reading
- The Microchip Web Site
- Customer Support
- Document Revision History

DOCUMENT LAYOUT

This document describes how to use the MCP3912 ADC Evaluation Board for 16-Bit MCUs as a development tool to emulate and debug firmware on a target board. The manual layout is as follows:

- **Chapter 1. “Product Overview”** – Provides important information about the MCP3912 ADC Evaluation Board for 16-Bit MCUs hardware.
- **Chapter 2. “Hardware Description”** – Provides information about the evaluation board software.
- **Chapter 3. “Firmware”** – Describes the MCP3912 ADC Evaluation Board for 16-Bit MCUs firmware.
- **Appendix A. “Schematics and Layouts”** – Shows the schematic and board layouts for the MCP3912 ADC Evaluation Board for 16-Bit MCUs.
- **Appendix B. “Bill of Materials (BOM)”** – Lists the parts used to build the MCP3912 ADC Evaluation Board for 16-Bit MCUs.

MCP3912 ADC Evaluation Board for 16-Bit MCUs User's Guide

CONVENTIONS USED IN THIS GUIDE

This manual uses the following documentation conventions:

DOCUMENTATION CONVENTIONS

Description	Represents	Examples
Arial font:		
Italic characters	Referenced books	<i>MPLAB[®] IDE User's Guide</i>
	Emphasized text	...is the <i>only</i> compiler...
Initial caps	A window	the Output window
	A dialog	the Settings dialog
	A menu selection	select Enable Programmer
Quotes	A field name in a window or dialog	"Save project before build"
Underlined, italic text with right angle bracket	A menu path	<u><i>File>Save</i></u>
Bold characters	A dialog button	Click OK
	A tab	Click the Power tab
N'Rnnnn	A number in verilog format, where N is the total number of digits, R is the radix and n is a digit.	4'b0010, 2'hF1
Text in angle brackets < >	A key on the keyboard	Press <Enter>, <F1>
Courier New font:		
Plain Courier New	Sample source code	#define START
	Filenames	autoexec.bat
	File paths	c:\mcc18\h
	Keywords	_asm, _endasm, static
	Command-line options	-Opa+, -Opa-
	Bit values	0, 1
	Constants	0xFF, 'A'
Italic Courier New	A variable argument	<i>file.o</i> , where <i>file</i> can be any valid filename
Square brackets []	Optional arguments	mcc18 [options] <i>file</i> [options]
Curly brackets and pipe character: { }	Choice of mutually exclusive arguments; an OR selection	errorlevel {0 1}
Ellipses...	Replaces repeated text	var_name [, var_name...]
	Represents code supplied by user	void main (void) { ... }

RECOMMENDED READING

This user's guide describes how to use MCP3912 ADC Evaluation Board for 16-Bit MCUs. Another useful document is listed below. The following Microchip document is available and recommended as a supplemental reference resource:

- **MCP3912 Data Sheet – “3V Four-Channel Analog Front End” (DS20005348A)**

THE MICROCHIP WEB SITE

Microchip provides online support via our web site at www.microchip.com. This web site is used as a means to make files and information easily available to customers. Accessible by using your favorite Internet browser, the web site contains the following information:

- **Product Support** – Data sheets and errata, application notes and sample programs, design resources, user's guides and hardware support documents, latest software releases and archived software
- **General Technical Support** – Frequently Asked Questions (FAQs), technical support requests, online discussion groups, Microchip consultant program member listing
- **Business of Microchip** – Product selector and ordering guides, latest Microchip press releases, listing of seminars and events, listings of Microchip sales offices, distributors and factory representatives

CUSTOMER SUPPORT

Users of Microchip products can receive assistance through several channels:

- Distributor or Representative
- Local Sales Office
- Field Application Engineer (FAE)
- Technical Support

Customers should contact their distributor, representative or field application engineer (FAE) for support. Local sales offices are also available to help customers. A listing of sales offices and locations is included in the back of this document.

Technical support is available through the web site at: <http://support.microchip.com>.

DOCUMENT REVISION HISTORY

Revision A (September 2014)

- Initial release of this document.



MCP3912 ADC EVALUATION BOARD FOR 16-BIT MCUs USER'S GUIDE

Chapter 1. Product Overview

1.1 OVERVIEW

The MCP3912 ADC Evaluation Board for 16-Bit MCUs system provides the opportunity to evaluate the performance of the MCP3912 four-channel Analog Front End (AFE). It also provides a development platform for 16-bit microcontroller-based applications, using the existing 100-pin PIC[®] microcontroller Plug-in Module (PIM) systems that are compatible with Explorer 16 Evaluation Board (DM240001) and other high pin count PIC device based demo boards. The system comes with a programmed PIC24FJ256GA110 PIM module that communicates with the Energy Management Utility software for data exchange and ADC setup.

The MCP3912 ADC Evaluation Board for 16-Bit MCUs uses the Energy Management Utility software for evaluation of the MCP3912 via a USB connection to the board. A download link for this software can be found on the evaluation board's web page. For instructions on the use of this software, refer to the supporting documentation included within the application install package.

1.1.1 Feature Highlights

- Four-channel ADC MCP3912 output display using serial communication to the PC software interface.
- Simultaneous 57 ksp/s at OSR32 address loop ALL or 95 dB SINAD at OSR512 performance on MCP3912.
- System and ADC performance analysis through graphical PC tools showing noise histogram, frequency domain (FFT), time domain scope plot and statistical numerical analysis.
- Robust hardware design with analog grounding and analog/digital separation, allowing low noise evaluation of the MCP3912 device; includes separate power supplies and power planes on a four-layer board.
- PICtail™ Plus connectors for Explorer 16 daughter board compatibility.

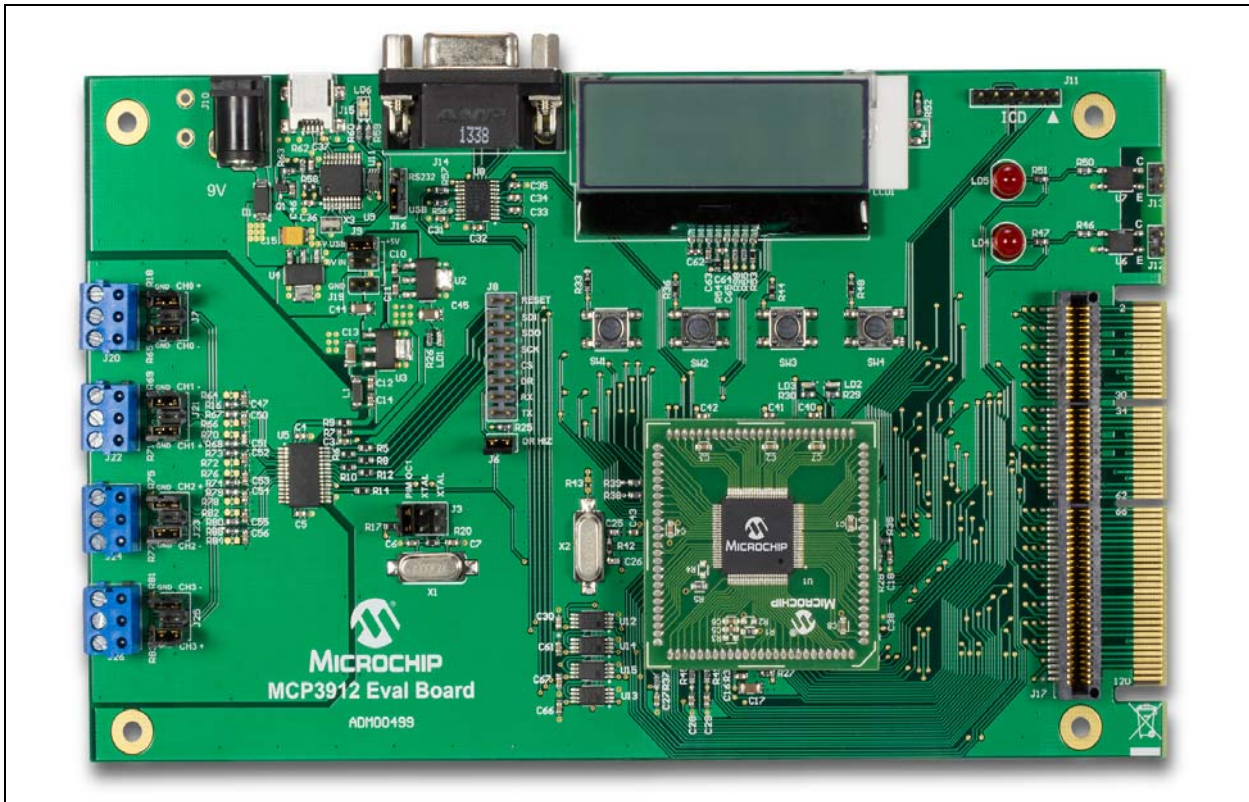

FIGURE 1-1: MCP3912 Evaluation Board.

1.2 WHAT THE MCP3912 ADC EVALUATION BOARD FOR 16-BIT MCUS CONTAINS

This MCP3912 ADC Evaluation Board for 16-Bit MCUs kit includes:

- MCP3912 ADC Evaluation Board for 16-Bit MCUs (Part number ADM00499)
- PIC24FJ256GA110 PIM
- USB Cable
- Important Information Sheet

Chapter 2. Hardware Description

2.1 PIM MODULE/MCP3912 CONNECTION AND PERIPHERAL USAGE OVERVIEW

The MCP3912 ADC Evaluation Board for 16-Bit MCUs contains a 100-pin PIM socket compatible with Microchip's PIM modules. The system comes with one PIM module, the PIC24FJ256GA110.

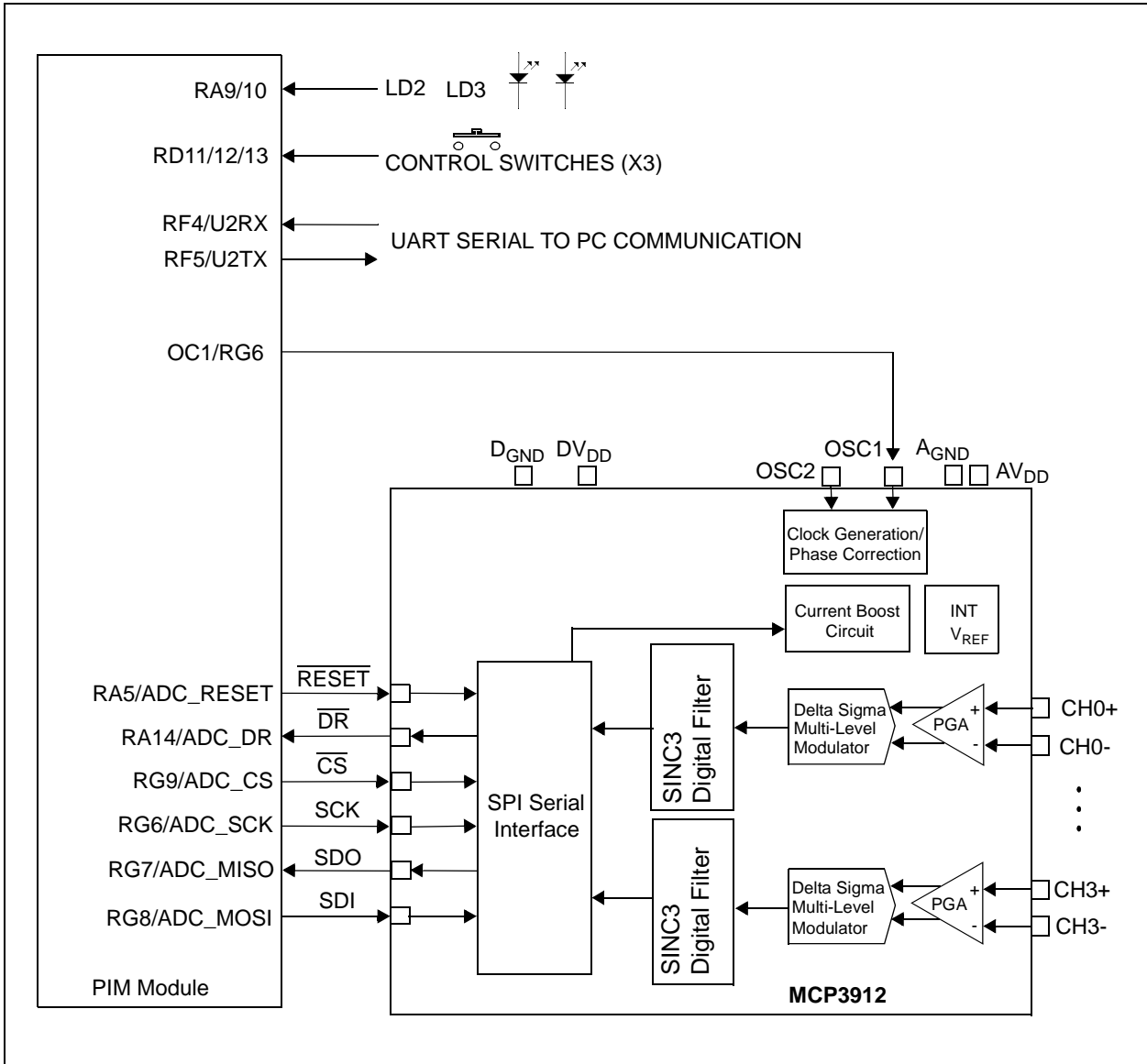

FIGURE 2-1: Digital Connection Overview PIM/MCP3912 Connections.

Ports A, D and G are used for signals such as push buttons, output LEDs, \overline{CS} and \overline{MCLR} (for the MCP3912 data mode setting). Output Compare 1 is used for clock generation in the MCP3912. Serial communication is achieved through the MSSP module 1.

The MCP3912 device is an Analog Front End (AFE) with four ADCs featuring a second order modulator and a third order sinc filter, plus a first order sinc filter used for higher OSR values. The delta-sigma A/D converters have an adjustable oversampling ratio. The CLKIN pin of the MCP3912 is the oversampling clock (MCLK) input. The MCP3912 ADC Evaluation Board for 16-Bit MCUs offers two different options for the MCP3912 master clock (MCLK). The default setting for the ADC internal clock is an external clock driven by the MCU.

2.1.1 Using the Crystal X1

The MCP3912 ADC Evaluation Board for 16-Bit MCUs is populated with a 10 MHz crystal, used as a clock source by placing jumpers in the following position on the MCP3912 Digital I/O header block:

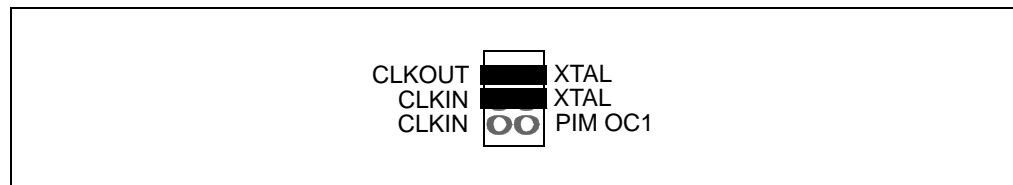

FIGURE 2-2: ADC Clock Selection Jumpers – External Crystal.

2.1.2 Driving the Clock with the PIM Module

The PIC MCU can be used to generate the CLKIN (MCLK) signal for the MCP3912, setting the ADC sample rate through the use of the output compare module OC1. To use this feature, make the following jumper change to the MCP3912 Digital I/O header block:

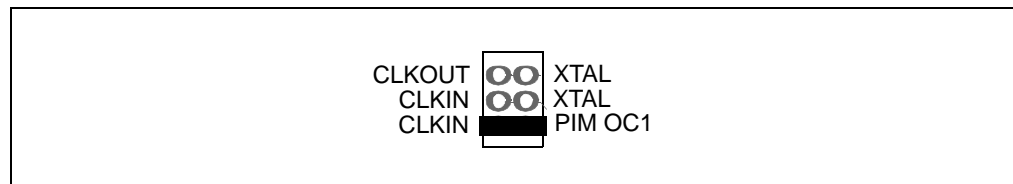

FIGURE 2-3: ADC Clock Selection Jumpers – Clock from MCU.

The frequency of the OC1 output is based on the PR1 bit settings in the firmware.

2.2 ANALOG INPUT STRUCTURE

Four differential input paths allow external signal sources to be easily connected to the MCP3912 inputs. Screw-terminal connectors J1, J4, J7, J21, J23, J25, J27 and J29 are 3-pin connectors that act as both screw-type and clip-on post connectors.

Note: To use a screw-terminal connector as a post connector, pull up the blue plastic top to access the posts.

The connectors J1, J4, J7, J21, J23 and J25 can be used to force either channel from a differential to single-ended configuration. R4 and R11 (on CH0), R19 and R21 (on CH1) R18 and R65 (on CH2), R69 and R71 (on CH3), R75 and R77 (on CH4) and R81 and RR83 (on CH5) act as locations for burden resistor connectors for any current transformer inputs.

MCP3912 ADC Evaluation Board for 16-Bit MCUs User's Guide

2.3 UNIVERSAL SERIAL BUS (USB)

The MCP3912 ADC Evaluation Board for 16-Bit MCUs also contains a USB connection for connecting the evaluation board to a PC. There is an MCP2200 USB to UART converter on the board that creates a virtual COMM port on the PC. The MCP3912 ADC Evaluation Board for 16-Bit MCUs also features an RS-232 connector, just in case it is required. The RS-232 line driver is connected to the same UART pins of the MCU. For this reason, a 3-pin jumper (J16) is present on the evaluation board to select which serial communication will be used: USB or RS-232. The following figure summarizes the connections between the ADC, MCU, USB to serial converter and the RS-232 line driver.

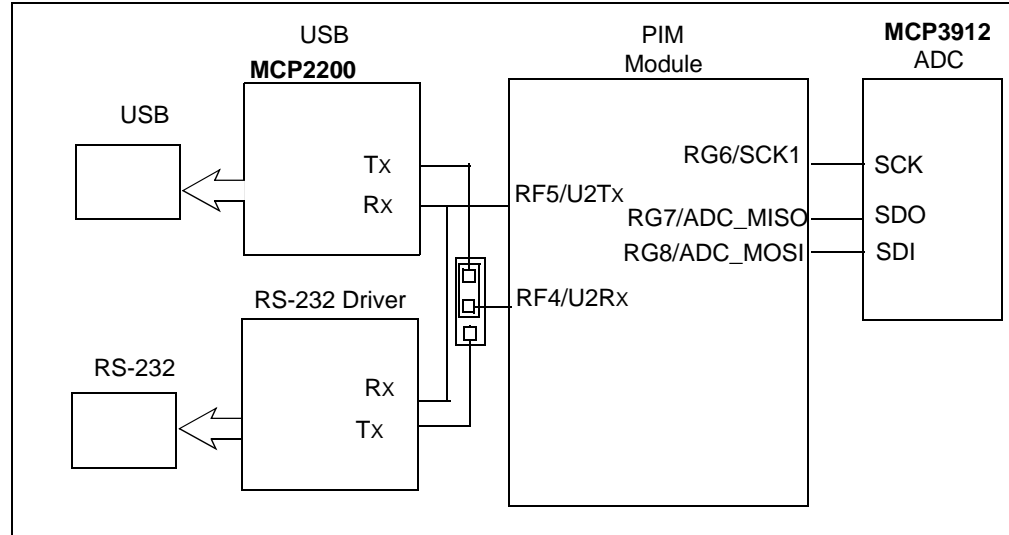

FIGURE 2-4: USB Block Diagram.

The MCP2200 is powered from the USB with 5V. The Q1 transistor (see [Appendix A. "Schematics and Layouts"](#)) is used to disconnect the board from the PC when it is powered-down to avoid power consumption. By changing the jumper J9 setting, the user can select the source of the power supply for the board to be either +5V derived from the USB or an external +9V power supply.

Since the PIC24F runs at 3.3V, a level shifter was used to modify the signal level to 5V as required by the MCP2200; this is done with U11 (see [Appendix A. "Schematics and Layouts"](#)).

The 7.3728 MHz value of the crystal is required to achieve the correct baud rate values for higher speed. This design uses a baud rate of 921.6 kbaud and for this baud rate, the register (U1BRG) value is 3 (decimal).

Chapter 3. Firmware

3.1 PIC24FJ256GA110 FIRMWARE DESCRIPTION

3.1.1 MCU Initialization

The microcontroller used for the code example is the 16-bit XLP with 16 MIPS PIC24FJ256GA110. The MCU has remappable pins and output compare with a dedicated time base.

The MCU uses a 7.3278 MHz crystal for the clock and the internal PLL to increase the frequency by four times. The uncommon crystal value was chosen to obtain the correct baud rate, even for high baud rates. The remappable pins are configured to make the PIM compatible with the Explorer 16 development board. The MCP3912 is linked with the MCU through the SPI1 port. The ADC clock is given by OC1. The DR pin of the MCP3912 is tied to external Interrupt 2.

Serial data transmission is carried out through the UART2 module. For transmission, OC2 interrupt is used; for receiving, the _U1RX Interrupt is used. The UART communication speed is 921.6 kbaud. OC2 is used for the serial transmission to create short bursts of data that can be processed by the MCP2200. Sending too many characters, with no time between them at the current baud rate, will cause the MCP2200 to lose data.

<p>Note: The PIC24FJ256GA110 must be Rev. A5 or newer in order for this code example to work.</p>
--

3.2 DATA ACQUISITION

External Interrupt 2 is used for detecting the end of conversion on the MCP3912. In the INT2 Interrupt, the data samples are read from the ADC using SPI.

When a new buffer begins to be read, Timer 4 is started. This is set as a 32-bit timer together with Timer 5. Timer 4 will be stopped when the buffer is full, and is used to measure the sampling speed.

Before reading the data samples, the MCU investigates the address loop setting (READ <1:0> bits) in the STATUSCOM register and adjusts the read sequence accordingly (when the address is not incremented automatically in hardware, the MCU has to do that in firmware, leading to a longer read sequence). The acquired samples are written in four long vectors created in the RAM of the MCU. The four vectors hold the first, second and third byte from both channels.

The vectors have a length of 2048. The value of Timer 4 and the values of the other registers inside the ADC are stored in a vector called "internal_registers[26]".

3.3 UART COMMUNICATION PROTOCOL

The serial connection is used to send the acquired data to the PC at a speed of 921.6 kbaud, and the MCP2200 is used for the UART-to-USB conversion.

The communication uses handshaking, meaning that the board will not send data to the PC unless the board receives a command from the PC.

The UART transmission is triggered by the output compare module OC2. This allows the data to be transmitted to the PC in short bursts that are separated by a dead time. This method of sending data allows the MCP2200 to handle the high throughput. If the entire amount of data is sent continuously to the PC at the current baud rate, the MCP2200 will not be able to process the data for correct USB transfer.

After a complete transmission, the UART RX interrupt is enabled by increasing its priority relative to all other interrupts. In this interrupt, the MCU needs to receive the values of the internal registers as the user is setting them in the PC GUI.



MCP3912 ADC EVALUATION BOARD FOR 16-BIT MCUs USER'S GUIDE

Appendix A. Schematics and Layouts

A.1 INTRODUCTION

This appendix contains the following schematics of the MCP3912 ADC Evaluation Board for 16-Bit MCUs:

- Board – Power Schematic
- Board – ADC Schematic
- Board – Microcontroller (MCU) Schematic
- Board – PIM Module Schematic
- Board – Top Silk
- Board – Top Copper and Silk
- Board – Top Copper
- Board – Internal Plane 1 and Assembly Top
- Board – Internal Plane 2 and Assembly Top
- Board – Bottom Copper
- Board – Bottom Copper and SILK
- Board – Bottom Silk

A.2 BOARD – POWER SCHEMATIC

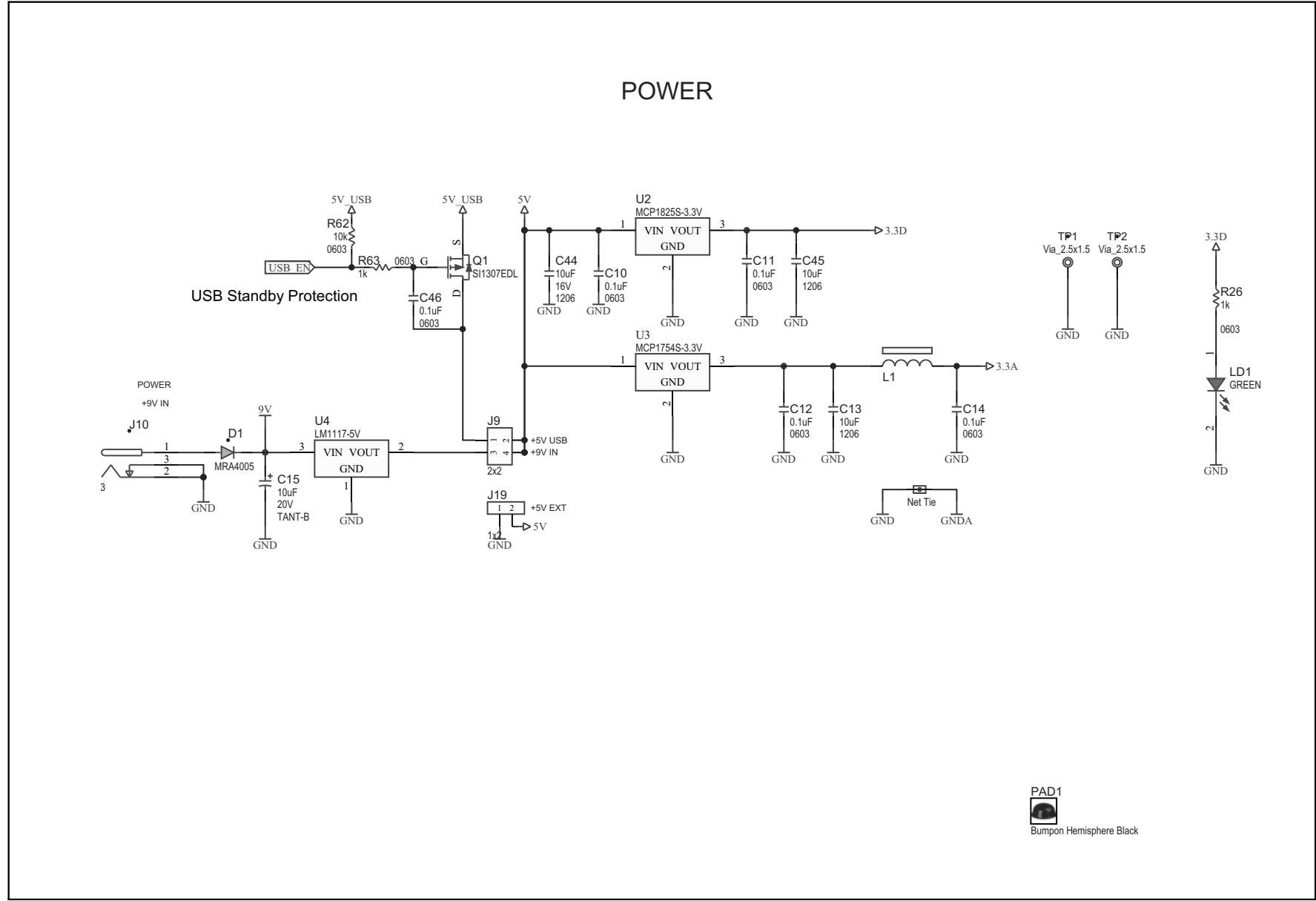

A.3 BOARD – ADC SCHEMATIC

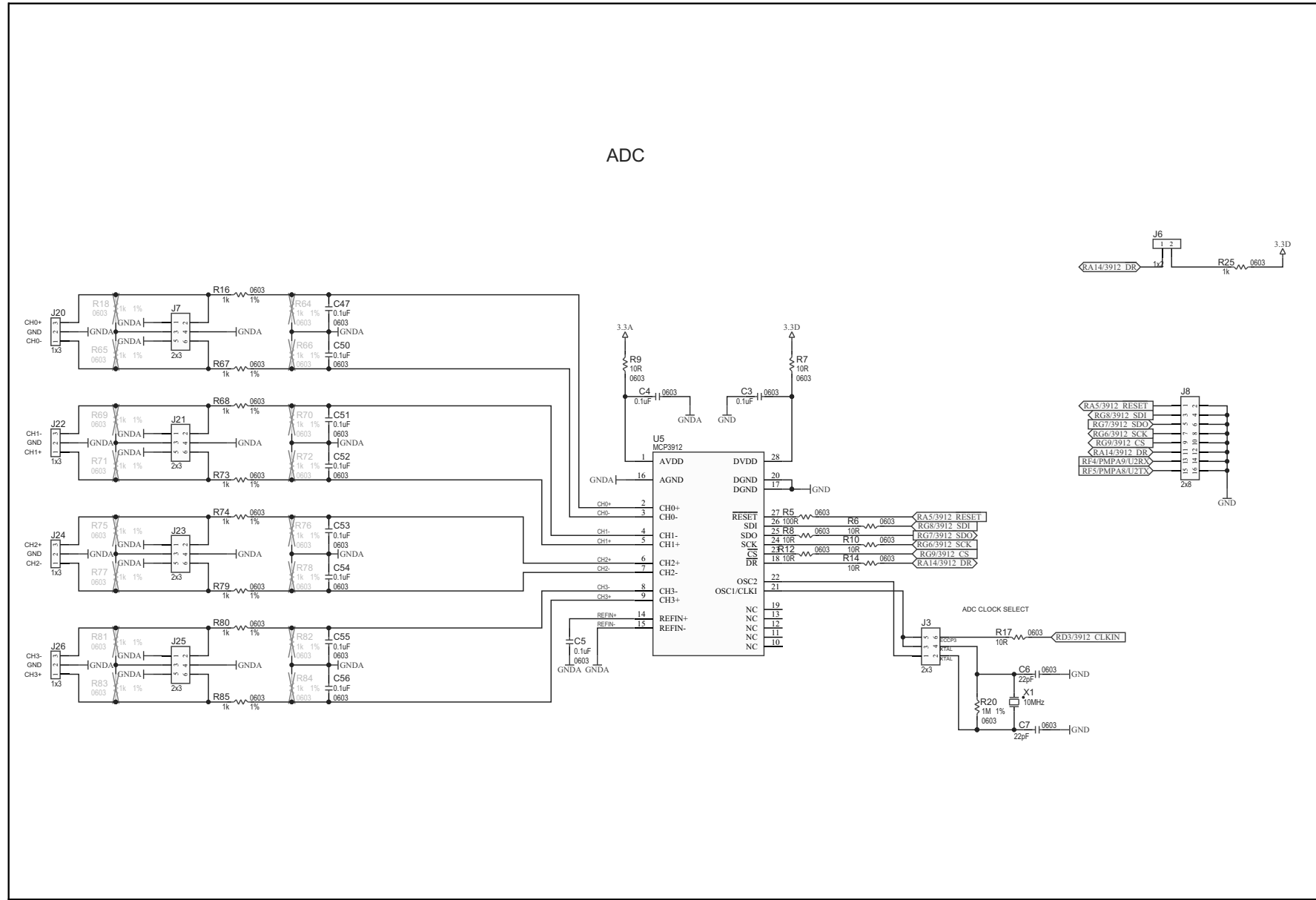

A.4 BOARD – MICROCONTROLLER (MCU) SCHEMATIC

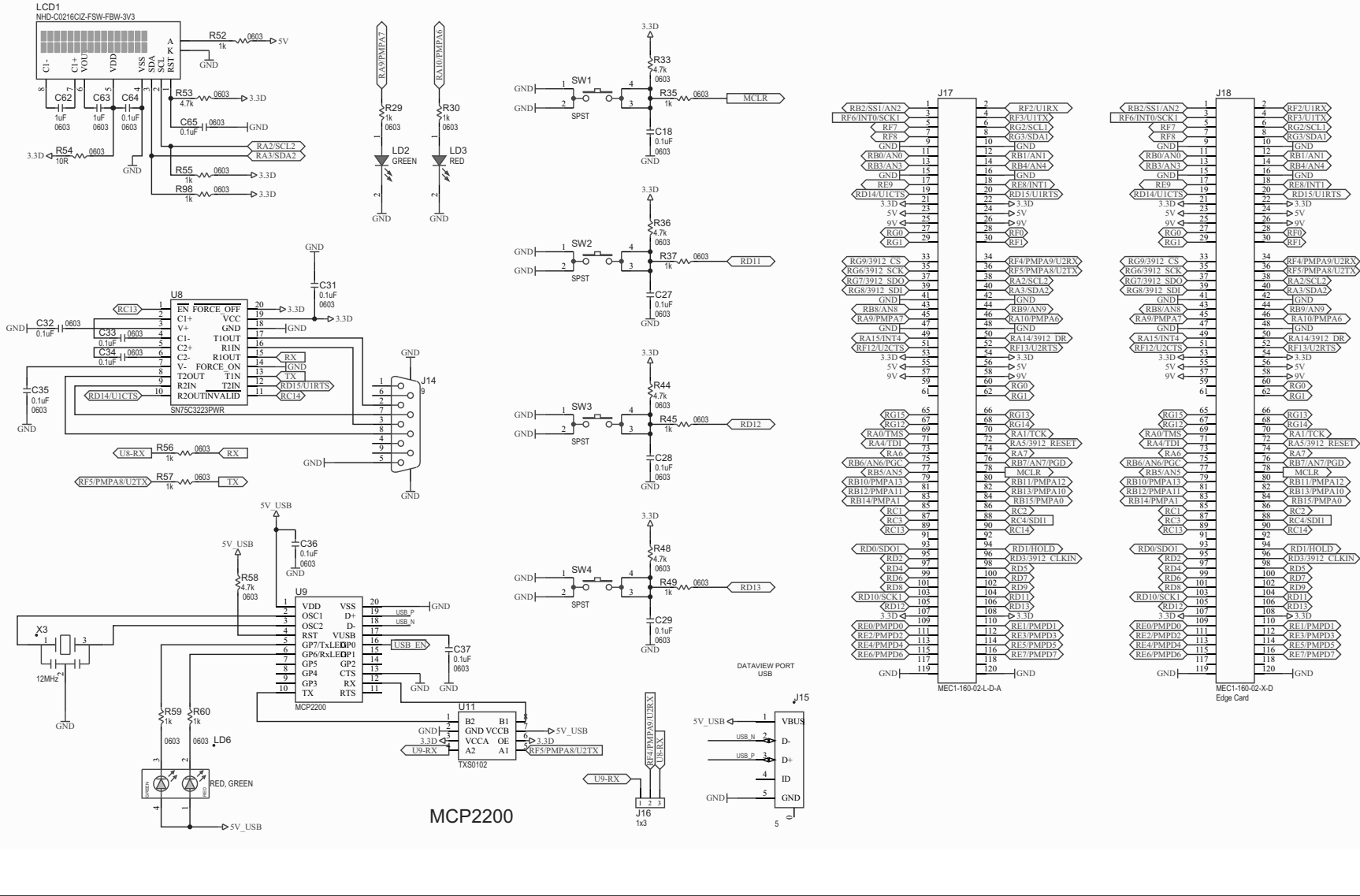

A.5 BOARD – PIM MODULE SCHEMATIC

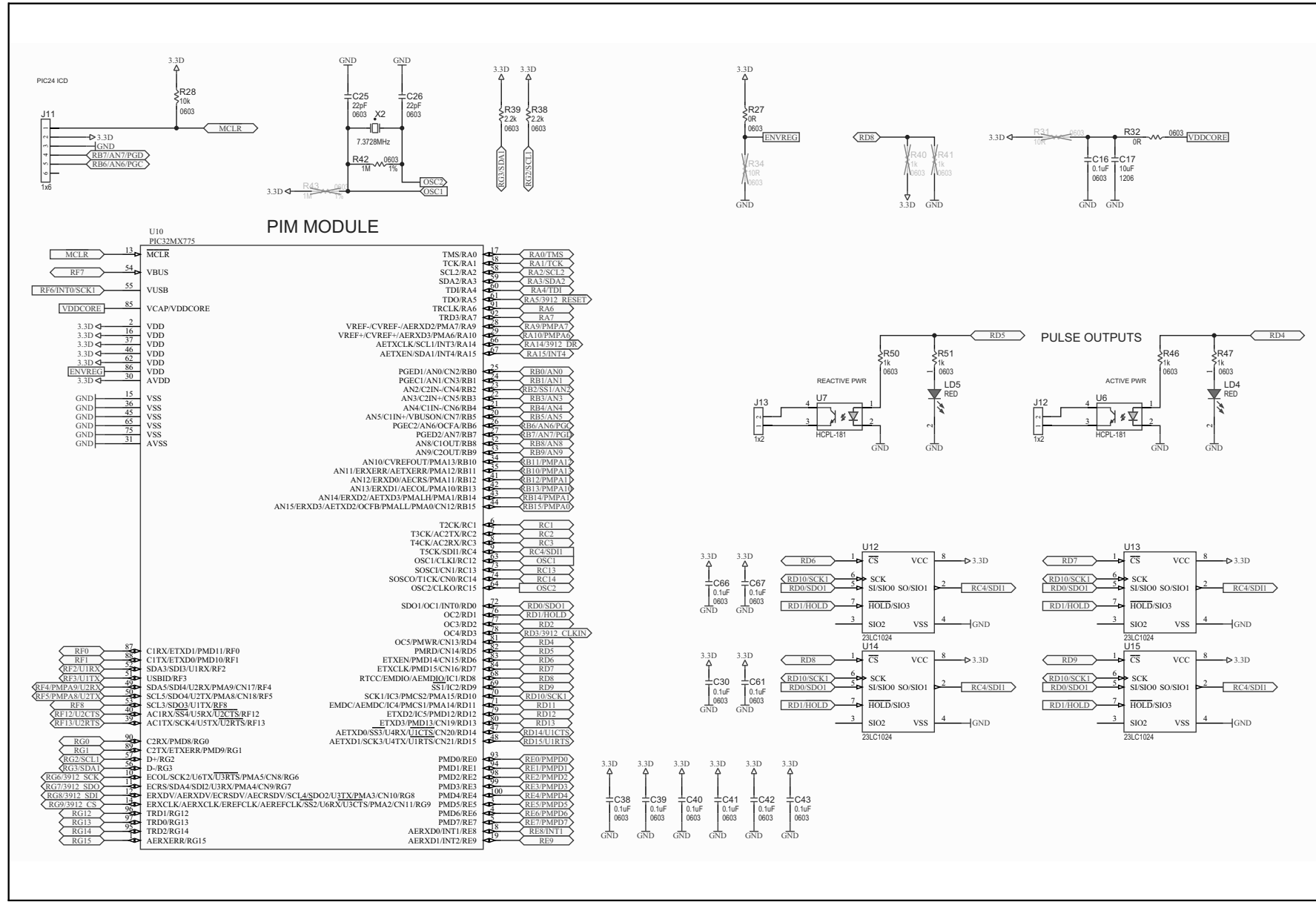

A.6 BOARD – TOP SILK

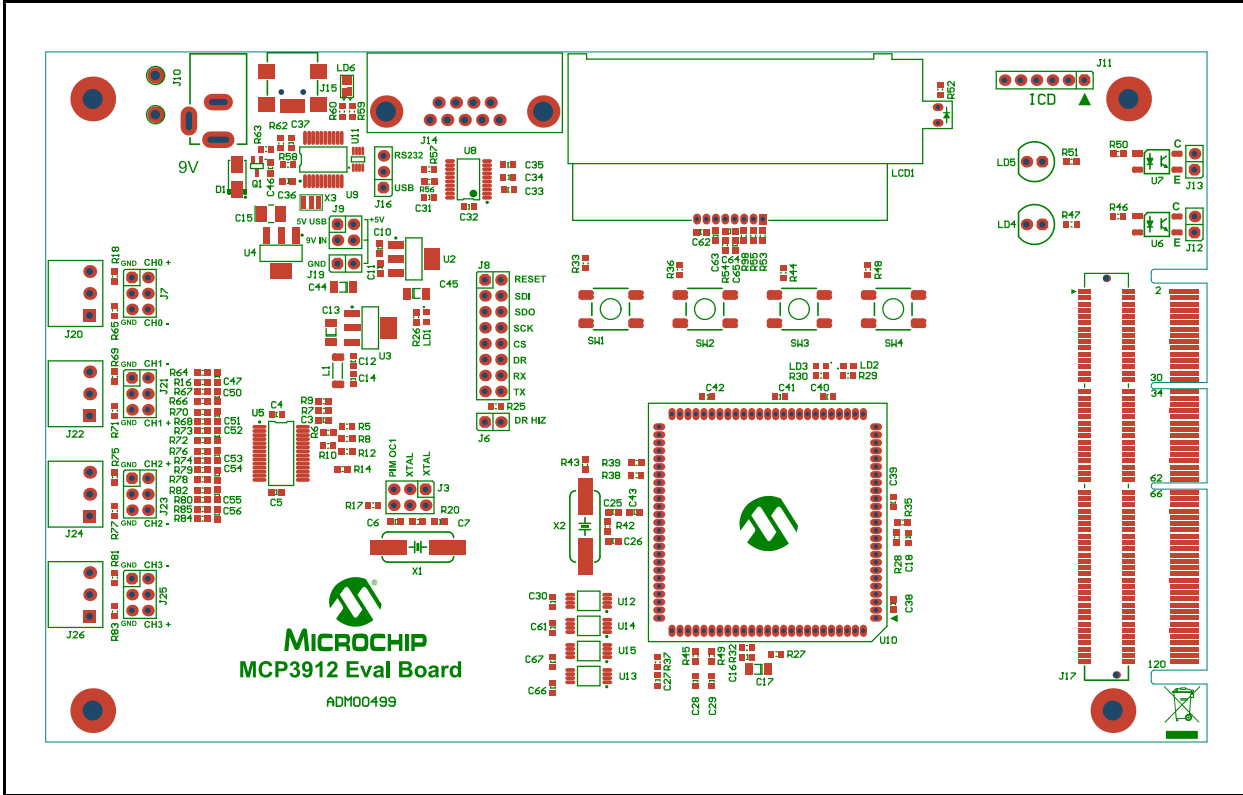

A.7 BOARD – TOP COPPER AND SILK

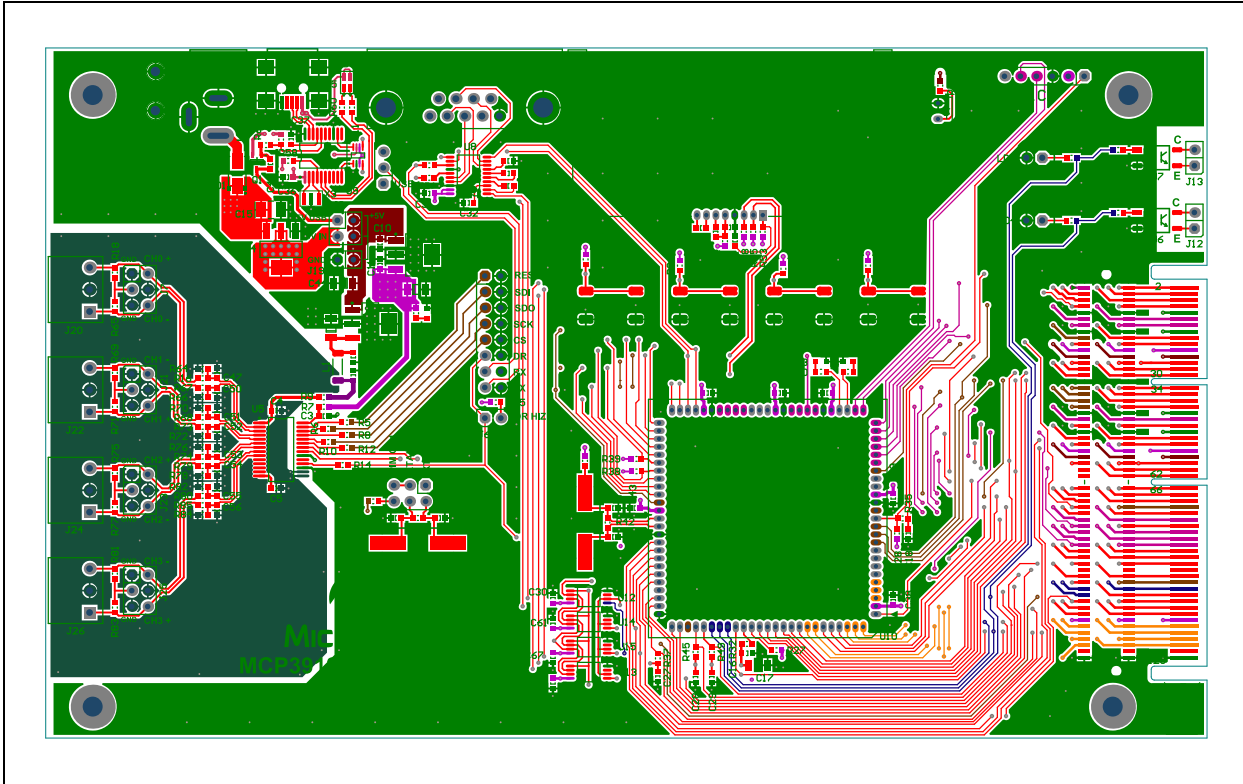

A.8 BOARD – TOP COPPER

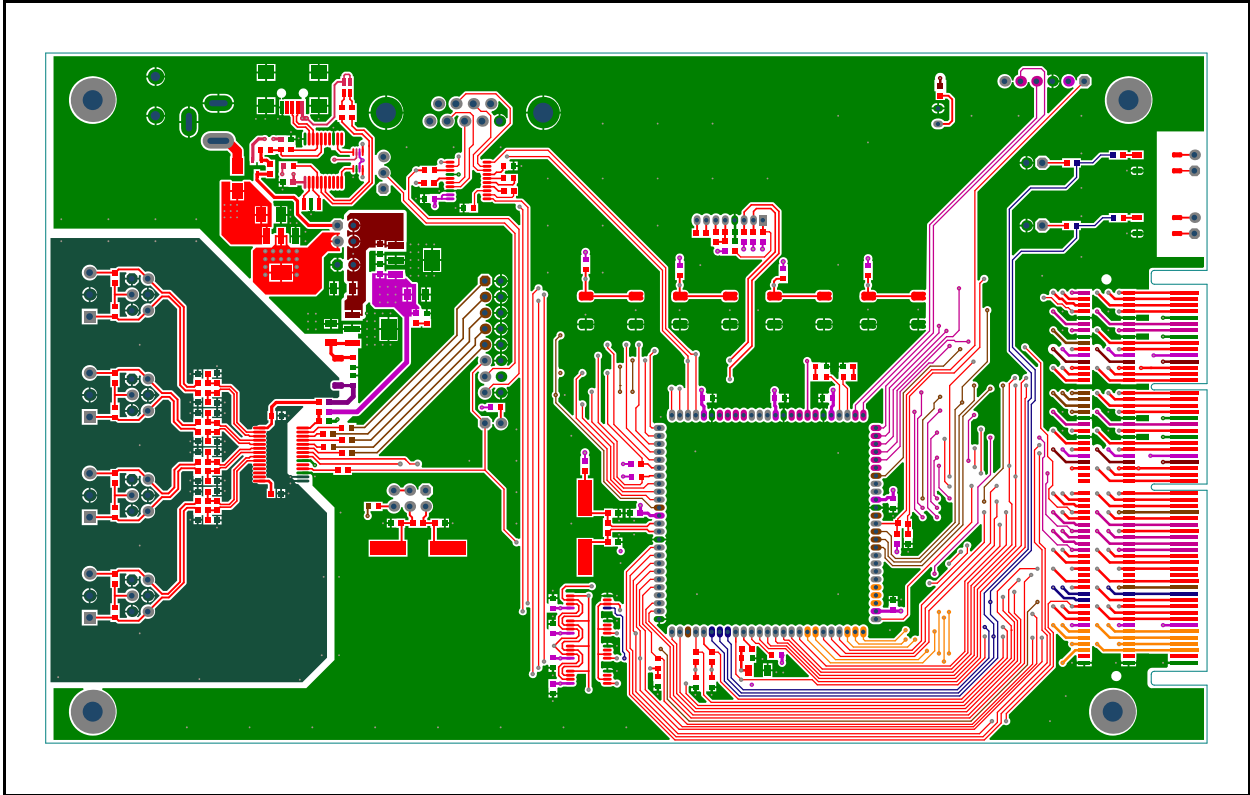

A.9 BOARD – INTERNAL PLANE 1 AND ASSEMBLY TOP

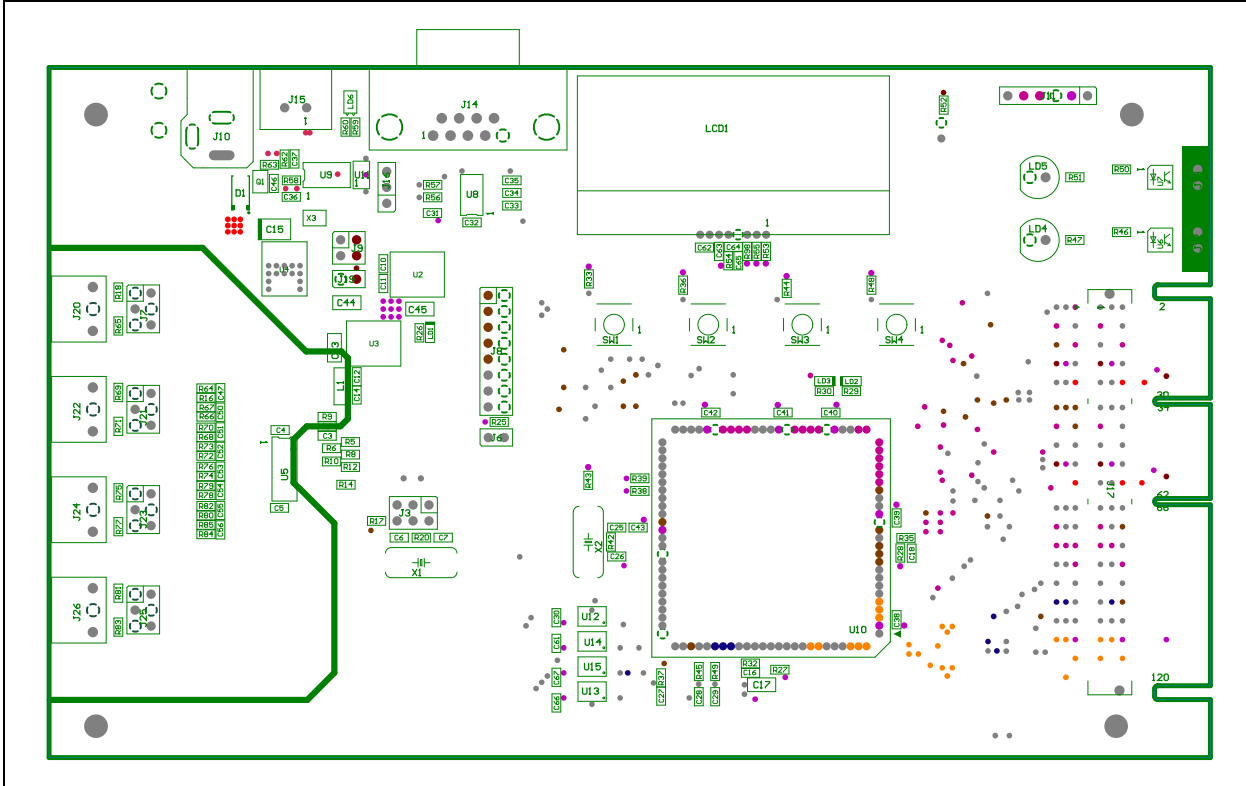

A.10 BOARD – INTERNAL PLANE 2 AND ASSEMBLY TOP

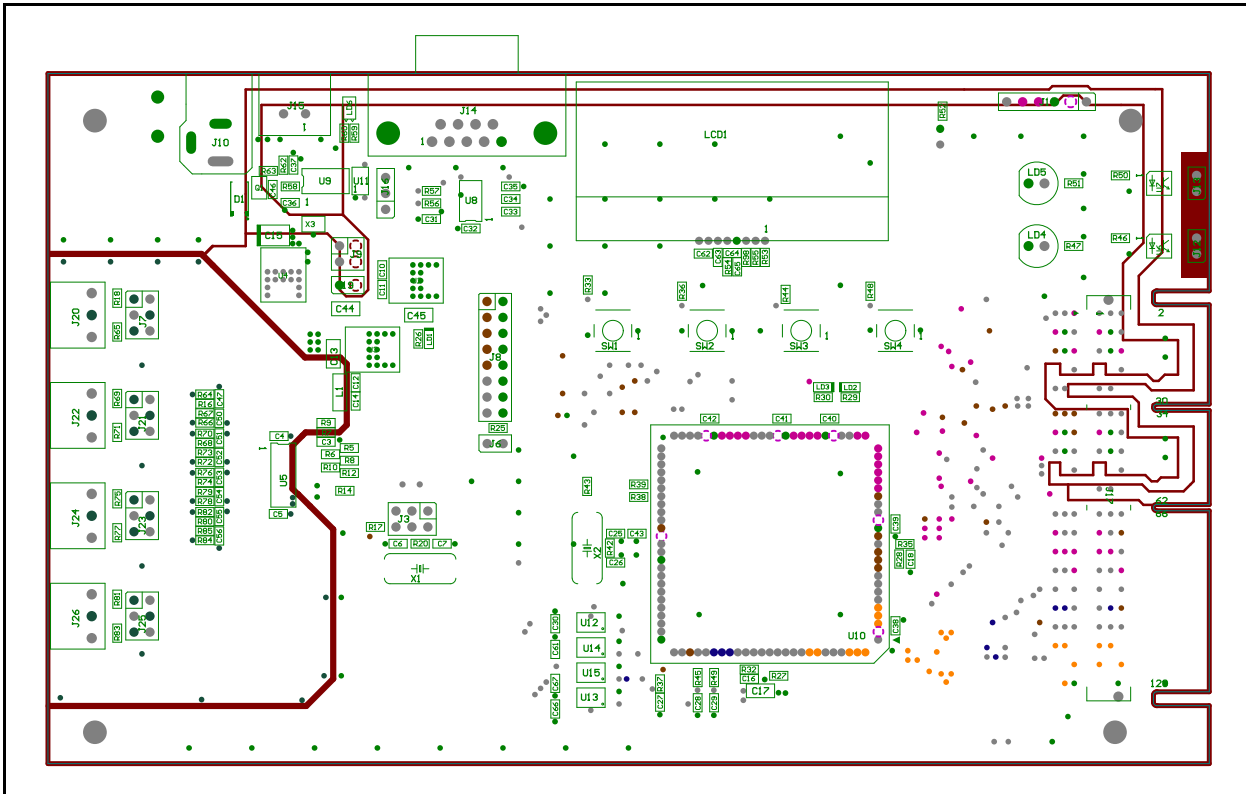

A.11 BOARD – BOTTOM COPPER

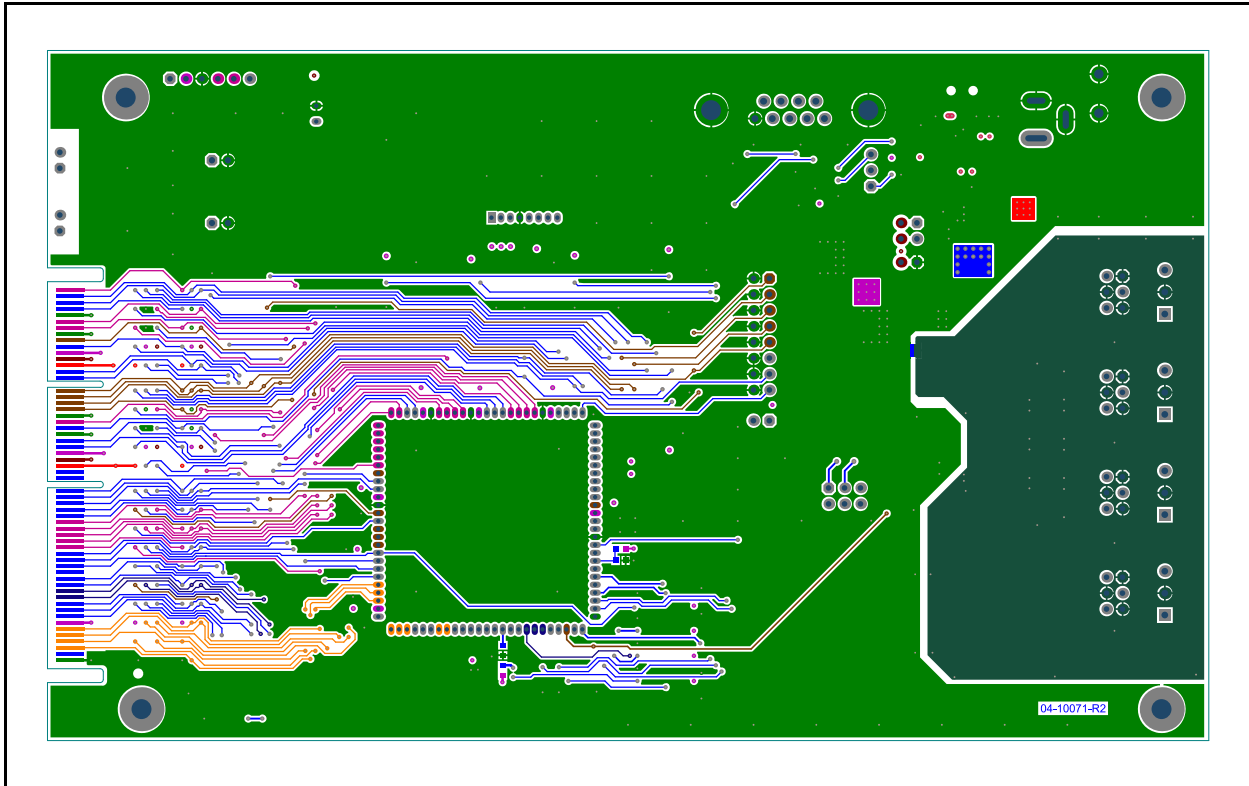

A.12 BOARD – BOTTOM COPPER AND SILK

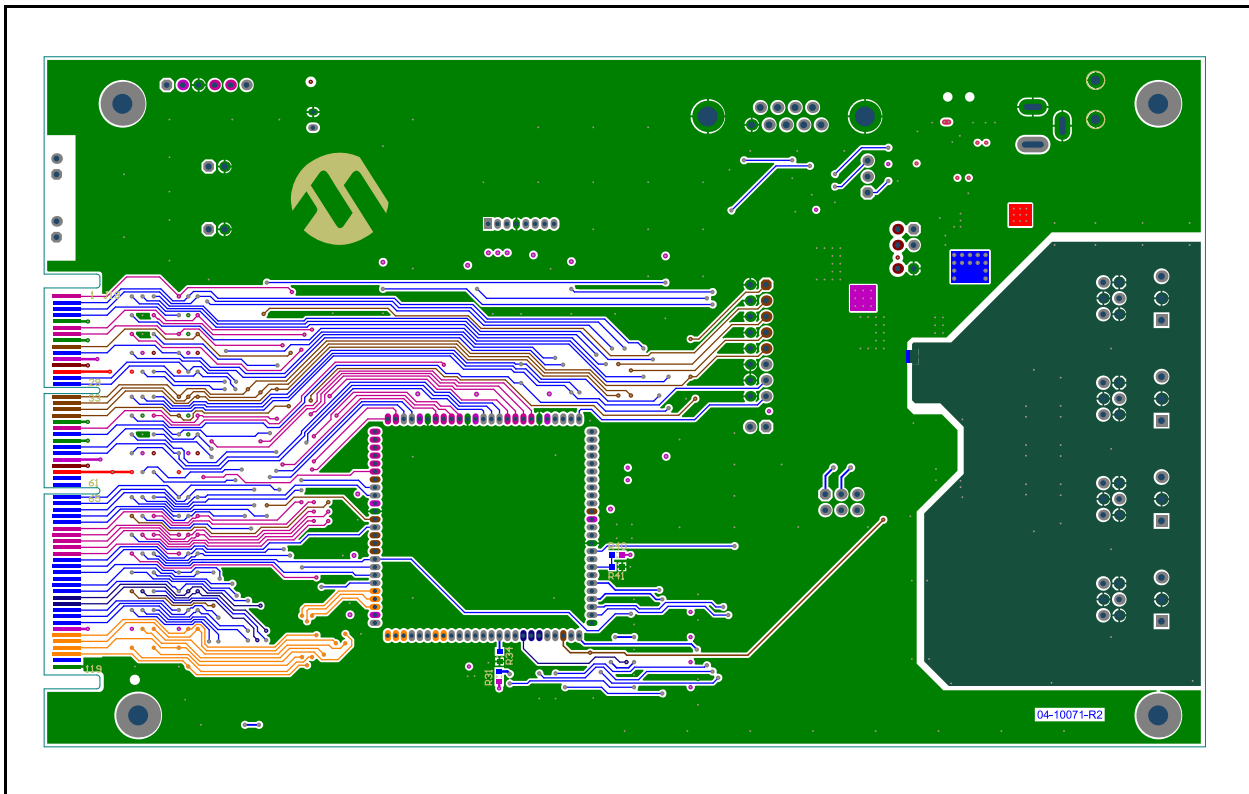

A.13 BOARD – BOTTOM SILK

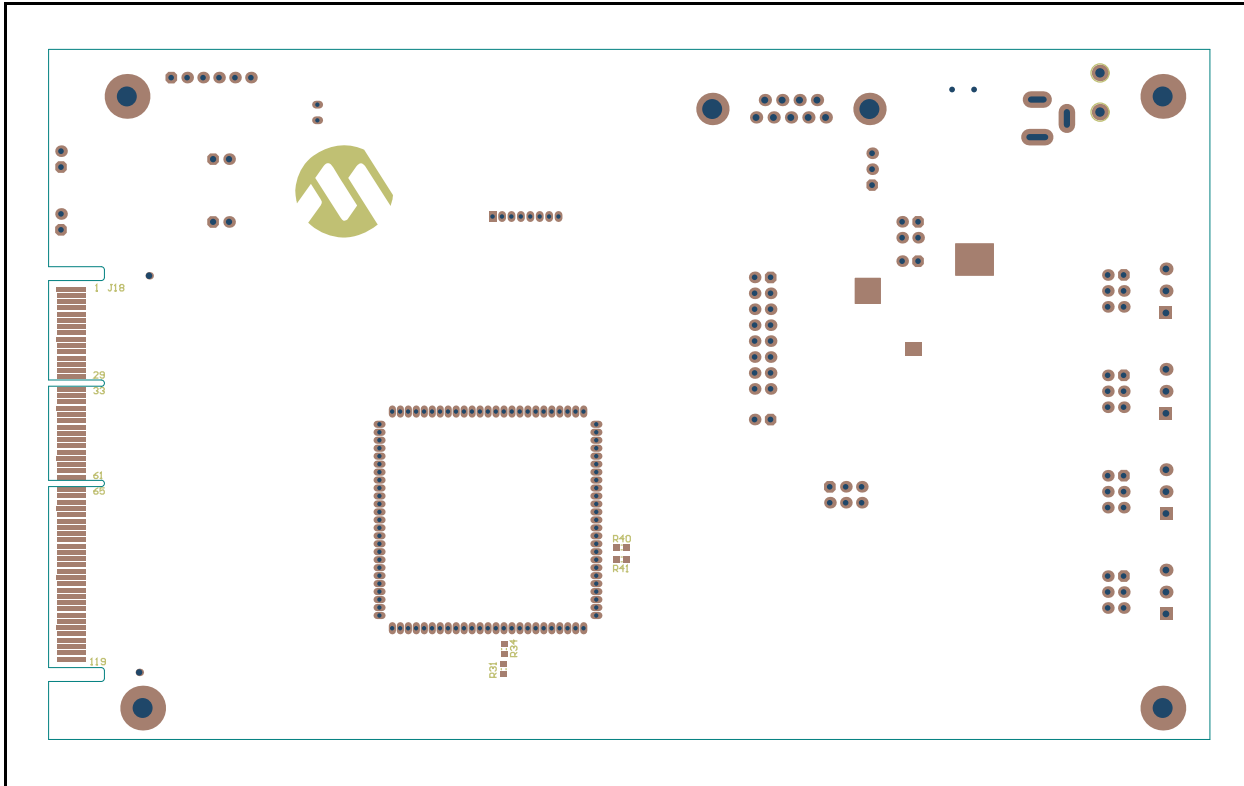

Appendix B. Bill of Materials (BOM)

TABLE B-1: BILL OF MATERIALS (BOM)

Qty	Reference	Description	Manufacturer	Part Number
40	C3, C4, C5, C10, C11, C12, C14, C16, C18, C27, C28, C29, C30, C31, C32, C33, C34, C35, C36, C37, C38, C39, C40, C41, C42, C43, C46, C47, C50, C51, C52, C53, C54, C55, C56, C61, C64, C65, C66, C67	Cap. ceramic 0.1 μ F 16V 10% X7R 0603	TDK Corporation	C1608X7R1C104K
3	C13, C44, C45	Cap. ceramic 10 μ F 16V 10% X5R SMD 1206	TDK Corporation	C3216X5R1C106K
1	C15	Cap. Tant. 10 μ F 20V 10% 2.1Ohm SMD B	AVX Corporation	TAJB106K020RNJ
1	C17	Cap. ceramic 10 μ F 10V 20% X7R SMD 1206	TDK Corporation	C3216X7R1A106M
4	C6, C7, C25, C26	Cap. ceramic 22 pF 50V 10% C0G SMD 0603	TDK Corporation	C1608C0G1H220J
2	C62, C63	Cap. ceramic 1 μ F 10V 20% X7R SMD 0603	TDK Corporation	C1608X7R1A105M
1	D1	Diode Rect. MRA4005 1.1V 1A 600V DO-214AC_SMA	ON Semiconductor®	MRA4005T3G
5	J3, J7, J21, J23, J25	Conn. header-2.54 Male 2x3 TH vert.	Samtec, Inc.	TSW-103-08-L-D
4	J6, J12, J13, J19	Conn. header-2.54 Male 1x2 TH vert.	FCI	77311-118-02LF
1	J8	Conn. header-2.54 Male 2x8 TH vert.	FCI	68602-116HLF
1	J9	Conn. header-2.54 100V 2A Male 2x2 TH vert.	3M	961204-6404-AR
1	J10	Conn. power jack 2.5mm	CUI Inc	PJ-002B
1	J11	Conn. header-2.54 Male 1x6 TH vert.	FCI	68001-106HLF
1	J14	Conn. DSUB 250V 2A DB-9-RA_F	TE Connectivity	1734354-2
1	J15	Conn. USB Mini USB-B Female SMD R/A	Hirose Electric Co., Ltd.	UX60-MB-5ST
1	J16	Conn. header-2.54 Male 1x3 TH vert.	Molex®	90120-0763
1	J17	Conn. Mini Edge Card MEC1 1mm Female 2x60 SMD vert.	Samtec, Inc.	MEC1-160-02-L-D-A

Note 1: The components listed in this Bill of Materials are representative of the PCB assembly. The released BOM used in manufacturing uses all RoHS-compliant components.

MCP3912 ADC Evaluation Board for 16-Bit MCUs User's Guide

TABLE B-1: BILL OF MATERIALS (BOM)

Qty	Reference	Description	Manufacturer	Part Number
4	J20, J22, J24, J26	Conn. terminal female 1x3 TH R/A	Keystone Electronics Corp.	8723
1	J20, J22, J24, J26	Pluggable terminal blocks 24 pin break-away header	Keystone Electronics Corp.	8724
1	L1	Ferrite 300mA 0.5R SMD 1806	Laird Technologies®	LI1806C151R-10
1	LCD1	Display LCD NHD-C0216-CIZ-FSW-FBW-3V3 16x2 Alpha 3.3V TH	Newhaven Display	NHD-C0216-CIZ-FSW-FBW-3V3
2	LD1, LD2	Diode LED green 1.7V 20 mA 0603	OSRAM Opto Semiconductors GmbH.	LG L29K-G2J1-24-Z
1	LD3	Diode LED red 2V 25 mA 0603	OSRAM Opto Semiconductors GmbH.	LS Q976-NR-1-0-20-R18
2	LD4, LD5	Diode LED red 1.65V 30 mA RAD T-1_3/4	Kingbright Corp	WP7113LSRD
1	LD6	Diode LED bi red, green 1.95V, 2.1V 30mA 0805	Kingbright Corp	APHBM2012SURKCGKC
1	Q1	Trans. Fet. P-CH SI1307EDL -12V -850 mA 290mW SOT-323-3	Vishay Siliconix	SI1307EDL-T1-GE3
1	R5	Res. 100 OHM 1/10W 1% 0603 SMD	Panasonic®	ERJ-3EKF1000V
9	R6, R7, R8, R9, R10, R12, R14, R17, R54	Res. TKF 10R 5% 1/10W SMD 0603	Yageo Corporation	RC0603JR-0710RL
8	R16, R67, R68, R73, R74, R79, R80, R85	Res. TKF 1k 1% 1/10W SMD 0603	Panasonic	ERJ-3EKF1001V
2	R20, R42	Res. TKF 1M 1% 1/10W SMD 0603	Panasonic	ERJ-3EKF1004V
20	R25, R26, R29, R30, R35, R37, R45, R46, R47, R49, R50, R51, R52, R55, R56, R57, R59, R60, R63, R98	Res. TKF 1k 5% 1/10W SMD 0603	Panasonic	ERJ-3GEYJ102V
2	R28, R62	Res. TKF 10k 5% 1/10W SMD 0603	Panasonic	ERJ-3GEYJ103V
2	R27, R32	Res. TKF 0R 1/10W SMD 0603	Panasonic	ERJ-3GEY0R00V
6	R33, R36, R44, R48, R53, R58	Res. TKF 4.7k 5% 1/10W SMD 0603	Yageo Corporation	RC0603JR-074K7L
2	R38, R39	Res. TKF 2.2k 5% 1/10W SMD 0603	Panasonic	ERJ-3GEYJ222V
4	SW1, SW2, SW3, SW4	Switch SPST 12V 50 mA TL3301NF160QG/TR SMD	E-Switch®, Inc.	TL3301NF160QG/TR
1	U4	IC Power LM1117-5V SOT-223-3	National Semiconductor	LM1117MPX-5.0/NOPB
2	U6, U7	IC Photo HCPL-181 4-SMD	Avago Technologies	HCPL-181-00CE
1	U8	IC Transceiver SN75C3223PWR TSSOP-20	Texas Instruments	SN75C3223PWR
4	U10	Socket PIM 100 pin female TH	Oupiin	2246-1X25G00SU
1	U11	IC Transceiver TXS0102 US-8	Texas Instruments	TXS0102DCUR
1	X1	Crystal 10 MHz 18pF SMD HC49/US	Abracon® Corporation	ABLS-10.000MHZ-B4-T

Note 1: The components listed in this Bill of Materials are representative of the PCB assembly. The released BOM used in manufacturing uses all RoHS-compliant components.

Bill of Materials (BOM)

TABLE B-1: BILL OF MATERIALS (BOM)

Qty	Reference	Description	Manufacturer	Part Number
1	X2	Crystal 7.3728 MHz 18 pF SMD HC49/US	Abracon Corporation	ABLS-7.3728MHZ-B4-T
1	X3	Resonator 12 MHz 0.1% SMD CSTCE-G	Murata Electronics®	CSTCE12M0G15L99-R0
1	U2	MCHP Ana. LDO MCP1825S-3.3V SOT-223-3	Microchip Technology Inc.	MCP1825S-3302E/DB
1	U3	MCHP Ana. LDO MCP1754ST-3302E/DB SOT-223-3	Microchip Technology Inc.	MCP1754ST-3302E/DB
1	U5	IC ADC 8 Ch Delta Sigma SSOP-28	Microchip Technology Inc.	MCP3912
1	U9	MCHP Int. USB MCP2200 SSOP-20	Microchip Technology Inc.	MCP2200-I/SS
4	U12, U13, U14, U15	MCHP Mem. SRAM 23LC1024 TSSOP-8	Microchip Technology Inc.	23LC1024-I/ST
5	PAD1	Mech. HW Rubber Pad Bumpon Hemisphere 0.44" x 0.20" Black	3M	SJ-5003 (BLACK)
0	R18, R64, R65, R66, R69, R70, R71, R72, R75, R76, R77, R78, R81, R82, R83, R84	DO NOT POPULATE – Res. TKF 1k 1% 1/10W SMD 0603	Panasonic	ERJ-3EKF1001V
0	R31, R34	DO NOT POPULATE – Res. TKF 10R 5% 1/10W SMD 0603	Yageo	RC0603JR-0710RL
0	R40, R41	DO NOT POPULATE – Res. TKF 1k 5% 1/10W SMD 0603	Panasonic	ERJ-3GEYJ102V
0	R43	DO NOT POPULATE – Res. TKF 1M 1% 1/10W SMD 0603	Panasonic	ERJ-3EKF1004V

Note 1: The components listed in this Bill of Materials are representative of the PCB assembly. The released BOM used in manufacturing uses all RoHS-compliant components.



MICROCHIP

Worldwide Sales and Service

AMERICAS

Corporate Office
2355 West Chandler Blvd.
Chandler, AZ 85224-6199
Tel: 480-792-7200
Fax: 480-792-7277
Technical Support:
<http://www.microchip.com/support>
Web Address:
www.microchip.com

Atlanta
Duluth, GA
Tel: 678-957-9614
Fax: 678-957-1455

Austin, TX
Tel: 512-257-3370

Boston
Westborough, MA
Tel: 774-760-0087
Fax: 774-760-0088

Chicago
Itasca, IL
Tel: 630-285-0071
Fax: 630-285-0075

Cleveland
Independence, OH
Tel: 216-447-0464
Fax: 216-447-0643

Dallas
Addison, TX
Tel: 972-818-7423
Fax: 972-818-2924

Detroit
Novi, MI
Tel: 248-848-4000

Houston, TX
Tel: 281-894-5983

Indianapolis
Noblesville, IN
Tel: 317-773-8323
Fax: 317-773-5453

Los Angeles
Mission Viejo, CA
Tel: 949-462-9523
Fax: 949-462-9608

New York, NY
Tel: 631-435-6000

San Jose, CA
Tel: 408-735-9110

Canada - Toronto
Tel: 905-673-0699
Fax: 905-673-6509

ASIA/PACIFIC

Asia Pacific Office
Suites 3707-14, 37th Floor
Tower 6, The Gateway
Harbour City, Kowloon
Hong Kong
Tel: 852-2943-5100
Fax: 852-2401-3431

Australia - Sydney
Tel: 61-2-9868-6733
Fax: 61-2-9868-6755

China - Beijing
Tel: 86-10-8569-7000
Fax: 86-10-8528-2104

China - Chengdu
Tel: 86-28-8665-5511
Fax: 86-28-8665-7889

China - Chongqing
Tel: 86-23-8980-9588
Fax: 86-23-8980-9500

China - Hangzhou
Tel: 86-571-8792-8115
Fax: 86-571-8792-8116

China - Hong Kong SAR
Tel: 852-2943-5100
Fax: 852-2401-3431

China - Nanjing
Tel: 86-25-8473-2460
Fax: 86-25-8473-2470

China - Qingdao
Tel: 86-532-8502-7355
Fax: 86-532-8502-7205

China - Shanghai
Tel: 86-21-5407-5533
Fax: 86-21-5407-5066

China - Shenyang
Tel: 86-24-2334-2829
Fax: 86-24-2334-2393

China - Shenzhen
Tel: 86-755-8864-2200
Fax: 86-755-8203-1760

China - Wuhan
Tel: 86-27-5980-5300
Fax: 86-27-5980-5118

China - Xian
Tel: 86-29-8833-7252
Fax: 86-29-8833-7256

China - Xiamen
Tel: 86-592-2388138
Fax: 86-592-2388130

China - Zhuhai
Tel: 86-756-3210040
Fax: 86-756-3210049

ASIA/PACIFIC

India - Bangalore
Tel: 91-80-3090-4444
Fax: 91-80-3090-4123

India - New Delhi
Tel: 91-11-4160-8631
Fax: 91-11-4160-8632

India - Pune
Tel: 91-20-3019-1500

Japan - Osaka
Tel: 81-6-6152-7160
Fax: 81-6-6152-9310

Japan - Tokyo
Tel: 81-3-6880-3770
Fax: 81-3-6880-3771

Korea - Daegu
Tel: 82-53-744-4301
Fax: 82-53-744-4302

Korea - Seoul
Tel: 82-2-554-7200
Fax: 82-2-558-5932 or
82-2-558-5934

Malaysia - Kuala Lumpur
Tel: 60-3-6201-9857
Fax: 60-3-6201-9859

Malaysia - Penang
Tel: 60-4-227-8870
Fax: 60-4-227-4068

Philippines - Manila
Tel: 63-2-634-9065
Fax: 63-2-634-9069

Singapore
Tel: 65-6334-8870
Fax: 65-6334-8850

Taiwan - Hsin Chu
Tel: 886-3-5778-366
Fax: 886-3-5770-955

Taiwan - Kaohsiung
Tel: 886-7-213-7830

Taiwan - Taipei
Tel: 886-2-2508-8600
Fax: 886-2-2508-0102

Thailand - Bangkok
Tel: 66-2-694-1351
Fax: 66-2-694-1350

EUROPE

Austria - Wels
Tel: 43-7242-2244-39
Fax: 43-7242-2244-393

Denmark - Copenhagen
Tel: 45-4450-2828
Fax: 45-4485-2829

France - Paris
Tel: 33-1-69-53-63-20
Fax: 33-1-69-30-90-79

Germany - Dusseldorf
Tel: 49-2129-3766400

Germany - Munich
Tel: 49-89-627-144-0
Fax: 49-89-627-144-44

Germany - Pforzheim
Tel: 49-7231-424750

Italy - Milan
Tel: 39-0331-742611
Fax: 39-0331-466781

Italy - Venice
Tel: 39-049-7625286

Netherlands - Drunen
Tel: 31-416-690399
Fax: 31-416-690340

Poland - Warsaw
Tel: 48-22-3325737

Spain - Madrid
Tel: 34-91-708-08-90
Fax: 34-91-708-08-91

Sweden - Stockholm
Tel: 46-8-5090-4654

UK - Wokingham
Tel: 44-118-921-5800
Fax: 44-118-921-5820

03/25/14



Компания «ЭлектроПласт» предлагает заключение долгосрочных отношений при поставках импортных электронных компонентов на взаимовыгодных условиях!

Наши преимущества:

- Оперативные поставки широкого спектра электронных компонентов отечественного и импортного производства напрямую от производителей и с крупнейших мировых складов;
- Поставка более 17-ти миллионов наименований электронных компонентов;
- Поставка сложных, дефицитных, либо снятых с производства позиций;
- Оперативные сроки поставки под заказ (от 5 рабочих дней);
- Экспресс доставка в любую точку России;
- Техническая поддержка проекта, помощь в подборе аналогов, поставка прототипов;
- Система менеджмента качества сертифицирована по Международному стандарту ISO 9001;
- Лицензия ФСБ на осуществление работ с использованием сведений, составляющих государственную тайну;
- Поставка специализированных компонентов (Xilinx, Altera, Analog Devices, Intersil, Interpoint, Microsemi, Aeroflex, Peregrine, Syfer, Eurofarad, Texas Instrument, Miteq, Cobham, E2V, MA-COM, Hittite, Mini-Circuits, General Dynamics и др.);

Помимо этого, одним из направлений компании «ЭлектроПласт» является направление «Источники питания». Мы предлагаем Вам помощь Конструкторского отдела:

- Подбор оптимального решения, техническое обоснование при выборе компонента;
- Подбор аналогов;
- Консультации по применению компонента;
- Поставка образцов и прототипов;
- Техническая поддержка проекта;
- Защита от снятия компонента с производства.



Как с нами связаться

Телефон: 8 (812) 309 58 32 (многоканальный)

Факс: 8 (812) 320-02-42

Электронная почта: org@eplast1.ru

Адрес: 198099, г. Санкт-Петербург, ул. Калинина, дом 2, корпус 4, литера А.