

Description

Single pole thermal circuit breaker with press-to-reset, tease-free, trip-free, snap action mechanism. Type 2-5000 is available with optional manual release (-H), type 2-5700 can be supplied as a push-push switch/circuit breaker (R-type TO CBE to EN 60934 in press-to-reset configuration; M-type when fitted with manual release -H; S-type with push-push operation). Fitted with flange or threadneck for panel mounting. Options include an additional unprotected circuit tap (-A3). Approved to CBE standard EN 60934 (IEC 60934).

Typical applications

Motors, transformers, solenoids, battery chargers, power supplies, appliances, machinery, extra low voltage systems.

Ordering information

Type No.	
2-5000	flange mounting
2-5700	threadneck panel mounting (hardware bulk shipped)
Threadneck design – type 2-5700 only	
iG1	moulded threadneck 3/8"-27UNS-2A
iG2	moulded threadneck M12x1
Terminal design	
P10	blade terminals 6.3-0.8 mm (QC .250)
K10	screw terminals M4x6
Manual release (optional)	
H	manual release facility (type 2-5000 only)
DD	push to release/push to reset (type 2-5700 only)
Current ratings	
0.05...25 A	
2-5700 -iG1 - P10 - DD - 8 A ordering example	

The exact part number required can be built up from the table of choices shown above. Ordering references for optional features should be omitted if not required.

Preferred types



Preferred types	Standard current ratings (A)												
	1	2	3	4	5	6	8	10	12	15	16	20	25
2-5700-IG1-P10-	x	x	x	x	x	x	x	x	x	x	x	x	x
2-5700-IG1-P10-DD			x	x	x	x	x	x	x	x	x	x	x
2-5700-IG2-P10-			x	x	x	x	x	x	x	x	x	x	x
2-5700-IG2-P10-DD			x	x	x	x	x	x	x	x	x	x	x

Approvals

Authority	Voltage ratings	Current ratings
VDE (EN 60934)	AC 250 V; DC 28 V	0.05...25 A
CSA/ UL	AC 250 V; DC 50 V	0.05...20 A
SEV	AC 250 V; DC 28 V	0.05...25 A
CCC	AC 250 V; DC 28 V	0.05...25 A

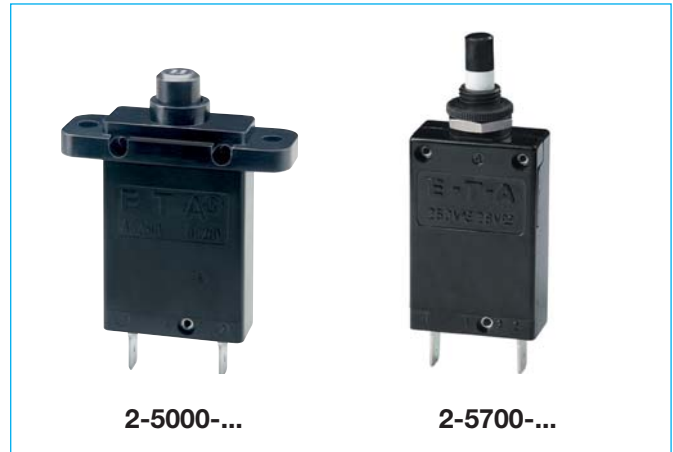

Technical data

For further details please see chapter: Technical Information

Voltage rating	AC 250 V; DC 28 V (UL: AC 250 V; DC 50 V)	
Current rating range	0.05...25 A	
Typical life	AC 250 V / DC 28 V: 0.05...16 A 5,000 operations at 2 x I _N , inductive 17...25 A 5,000 operations at 2 x I _N , resistive	
Ambient temperature	-20...+60 °C (-4...+140 °F)	
Insulation co-ordination (IEC 60664 and 60664 A)	rated impulse withstand voltage 2.5 kV reinforced insulation in operating area	pollution degree 2
Dielectric strength (IEC 60664 and 60664 A) operating area	test voltage AC 3,000 V	
Insulation resistance	> 100 MΩ (DC 500 V)	
Interrupting capacity I _{cn}	0.05...2.5 A 3...5 A 6...12 A 13...25 A	8 x I _N 20 x I _N 200 A 300 A (higher interrupting capacity available to special order)
Interrupting capacity (UL 1077)	I _N 0.05...20 A 0.05...25 A	U _N AC 250 V 2,000 A DC 50 V 2,500 A (higher values upon request)
Degree of protection (IEC 60529/DIN 40050)	operating area IP40 terminal area IP00	
Vibration	8 g (57-500 Hz) ± 0.61 mm (10-57 Hz), to IEC 60068-2-6, test Fc, 10 frequency cycles/axis	
Shock	25 g (11 ms) to IEC 60068-2-27, test Ea	
Corrosion	96 hours at 5 % salt mist, to IEC 60068-2-11, test Ka	
Humidity	240 hours at 95 % RH to IEC 60068-2-78, test Cab	
Mass	approx. 29 g	

Dimensions

2-5000-P10

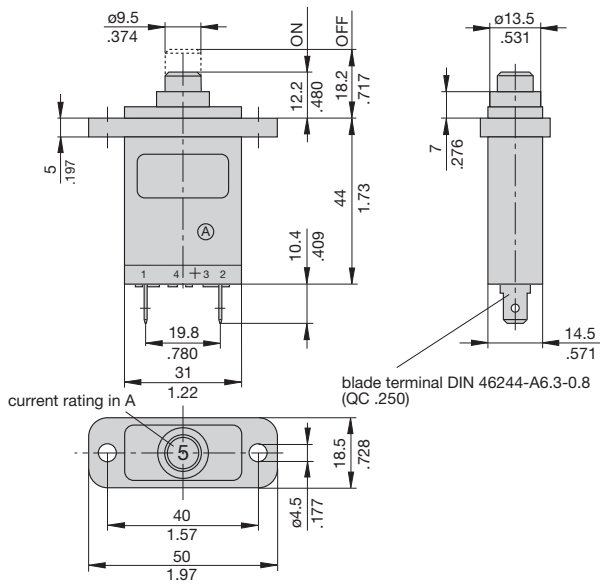

2-5700-P10

3/8

iG1=3/8-27UNS-2A tightening torque max. 1 Nm
iG2=M12x1 tightening torque max. 1.5 Nm

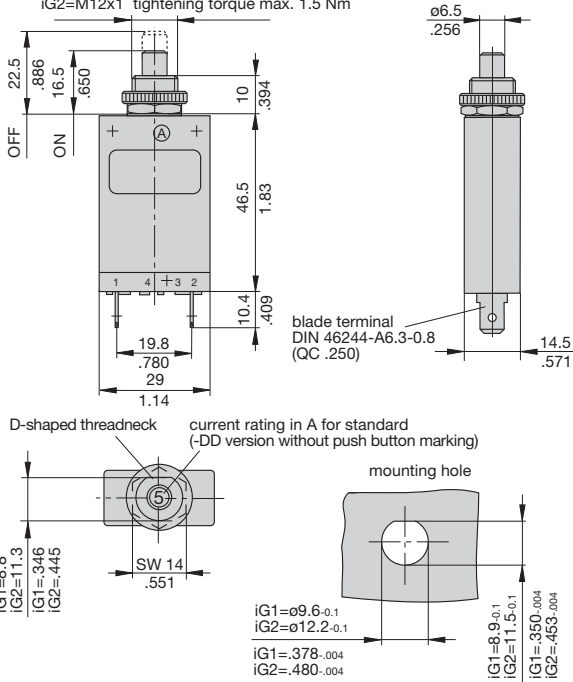

Terminal design

-K10

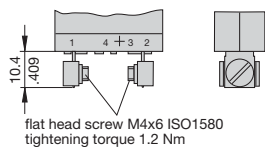

Installation drawings

2-5000-P10

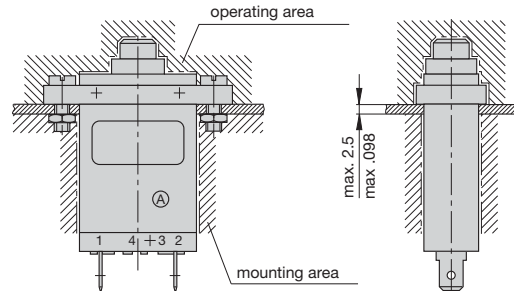

2-5700-P10

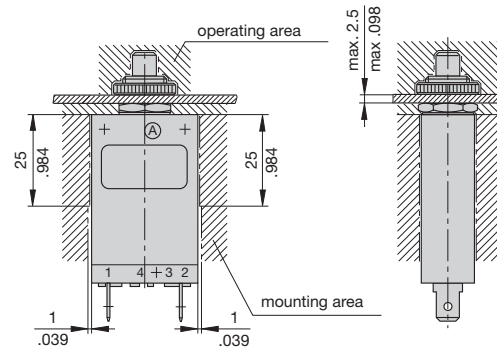

Standard current ratings and typical internal resistance values

Current rating (A)	Internal resistance (Ω)	Current rating (A)	Internal resistance (Ω)
0.05	280	3	0.1
0.08	100	3.5	0.06
0.1	110	4	0.06
0.2	29	4.5	0.05
0.3	14	5	0.05
0.4	7	6	0.02
0.5	4.9	7	0.02
0.6	3.4	8	0.02
0.7	2.5	10	< 0.02
0.8	1.8	12	< 0.02
1	1.2	13	< 0.02
1.2	0.8	15	< 0.02
1.5	0.6	16	< 0.02
1.8	0.4	20	< 0.02
2	0.3	22	< 0.02
2.5	0.2	25	< 0.02

This is a metric design and millimeter dimensions take precedence (mm/inch)

Typical time/current characteristics at +23 °C/+73.4 °F

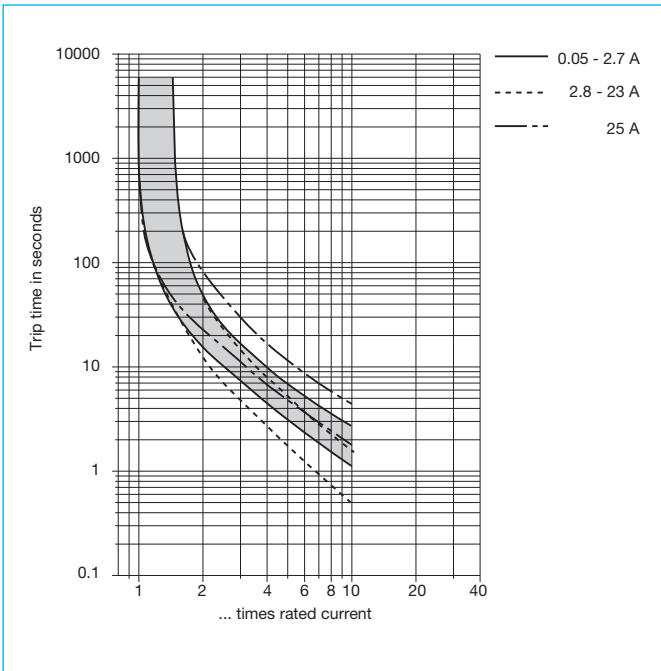

The time/current characteristic curve depends on the ambient temperature prevailing. In order to eliminate nuisance tripping, please multiply the circuit breaker current ratings by the derating factor shown below. See also section Technical information.

Ambient temperature °F	-4	+14	+32	+73.4	+104	+122	+140
°C	-20	-10	0	+23	+40	+50	+60
Derating factor	0.76	0.84	0.92	1	1.08	1.16	1.24

Internal connection diagrams

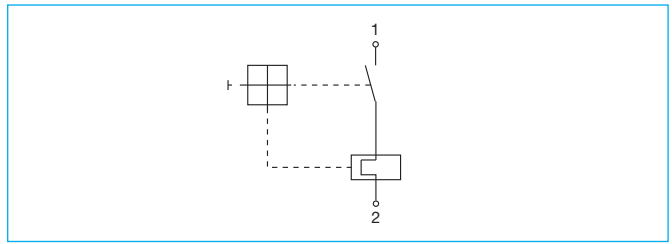

This is a metric design and millimeter dimensions take precedence ($\frac{\text{mm}}{\text{inch}}$)

Accessories for types 2-5000 and 2-5700 with screw terminals -K10

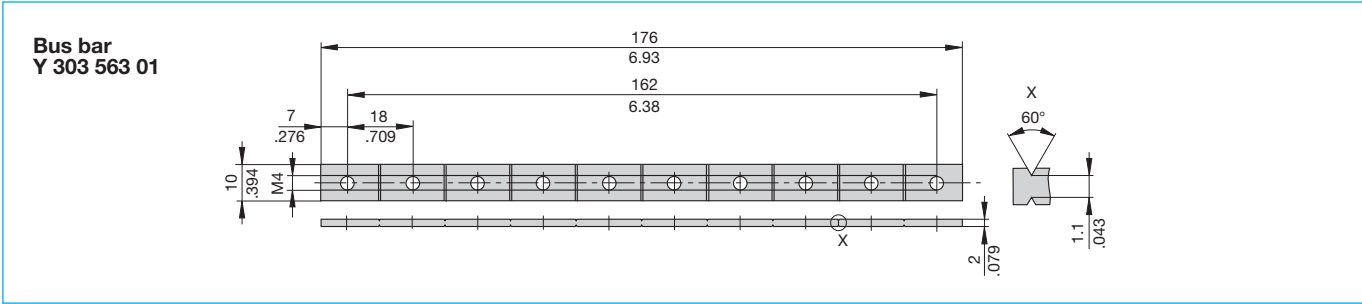

Accessories for type 2-5000-...

**Water splash cover, transparent for push button (IP64)
Y 300 728 01**

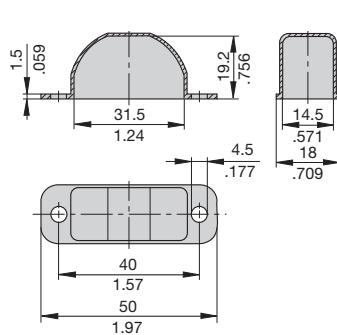

**Fixing plate
Y 301 056 02**

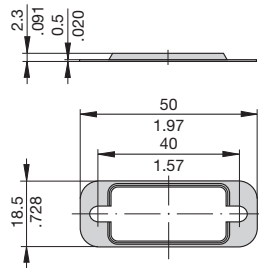

**Rear terminal shroud, transparent (IP64)
Y 300 476 01**

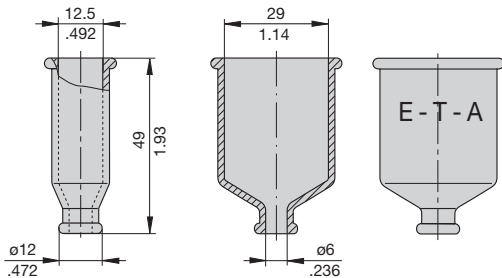

Accessories for type 2-5700-...

With 3/8" threadneck (-iG1)

Water splash cover, transparent Y 300 538 01 and knurled nut Y 300 628 01 X 200 799 01 (IP64)

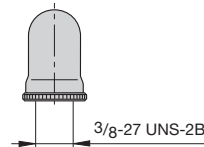

Water splash cover, transparent with special knurled nut X 200 798 02 (IP64)

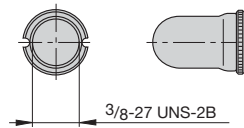

Hex nut with splash cover black without O ring X 210 739 01 (IP64) transparent splash cover X 201 296 03 (IP64)

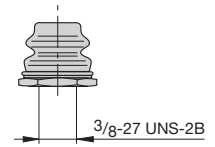

**Separate hardware
Hex nut
Y 300 192 01**

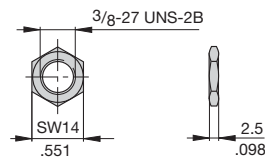

**Knurled nut
Y 307 117 02**

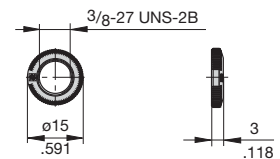

With M12 threadneck (-iG2)

Hex nut with splash cover, black X 201 296 01 without O ring (IP64) X 200 801 03 with O ring (IP66 and IP67)

Hex nut with splash cover, transparent X 200 801 08 with O ring (IP66 and IP67)



Water splash cover, transparent with knurled nut and O ring X 210 663 01 (IP64)

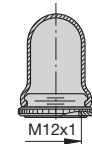

**Hex nut
Y 300 116 02**

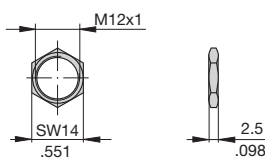

**Knurled nut
Y 302 065 01**

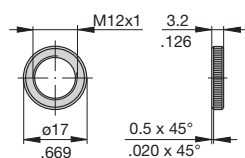

This is a metric design and millimeter dimensions take precedence (mm/inch)

All dimensions without tolerances are for reference only. In the interest of improved design, performance and cost effectiveness the right to make changes in these specifications without notice is reserved. Product markings may not be exactly as the ordering codes. Errors and omissions excepted.



Компания «ЭлектроПласт» предлагает заключение долгосрочных отношений при поставках импортных электронных компонентов на взаимовыгодных условиях!

Наши преимущества:

- Оперативные поставки широкого спектра электронных компонентов отечественного и импортного производства напрямую от производителей и с крупнейших мировых складов;
- Поставка более 17-ти миллионов наименований электронных компонентов;
- Поставка сложных, дефицитных, либо снятых с производства позиций;
- Оперативные сроки поставки под заказ (от 5 рабочих дней);
- Экспресс доставка в любую точку России;
- Техническая поддержка проекта, помощь в подборе аналогов, поставка прототипов;
- Система менеджмента качества сертифицирована по Международному стандарту ISO 9001;
- Лицензия ФСБ на осуществление работ с использованием сведений, составляющих государственную тайну;
- Поставка специализированных компонентов (Xilinx, Altera, Analog Devices, Intersil, Interpoint, Microsemi, Aeroflex, Peregrine, Syfer, Eurofarad, Texas Instrument, Miteq, Cobham, E2V, MA-COM, Hittite, Mini-Circuits, General Dynamics и др.);

Помимо этого, одним из направлений компании «ЭлектроПласт» является направление «Источники питания». Мы предлагаем Вам помощь Конструкторского отдела:

- Подбор оптимального решения, техническое обоснование при выборе компонента;
- Подбор аналогов;
- Консультации по применению компонента;
- Поставка образцов и прототипов;
- Техническая поддержка проекта;
- Защита от снятия компонента с производства.



Как с нами связаться

Телефон: 8 (812) 309 58 32 (многоканальный)

Факс: 8 (812) 320-02-42

Электронная почта: org@eplast1.ru

Адрес: 198099, г. Санкт-Петербург, ул. Калинина, дом 2, корпус 4, литера А.