

Features

- Low Insertion Loss and Noise Figure
- High Peak and Average Operating Power
- Various P1dB Compression Powers
- Au Doped Devices for Lower Recovery Time
- Non-Au doped devices for Lower Flat Leakage Power
- Proven Reliable, Silicon Nitride Passivation
- RoHS Compliant

Description

The MA4L and MADL Series are silicon PIN limiter diodes with small and medium I-region lengths which are specifically designed for high signal applications. The devices are designed to provide low insertion loss, at zero bias, as well as low flat leakage power with fast signal response/recovery times. Parts are available as discrete die or assembled into a variety of surface mount or ceramic pill packages. See the Available Case Style table for the specific ceramic package styles and their availability for individual part numbers.

Applications

The MA4L and MADL Series of PIN limiter diodes are designed for use in passive limiter control circuits to protect sensitive receiver components such as low noise amplifiers (LNA), detectors, and mixers covering the 10 MHz to 18 GHz frequency range.

Available Packages¹

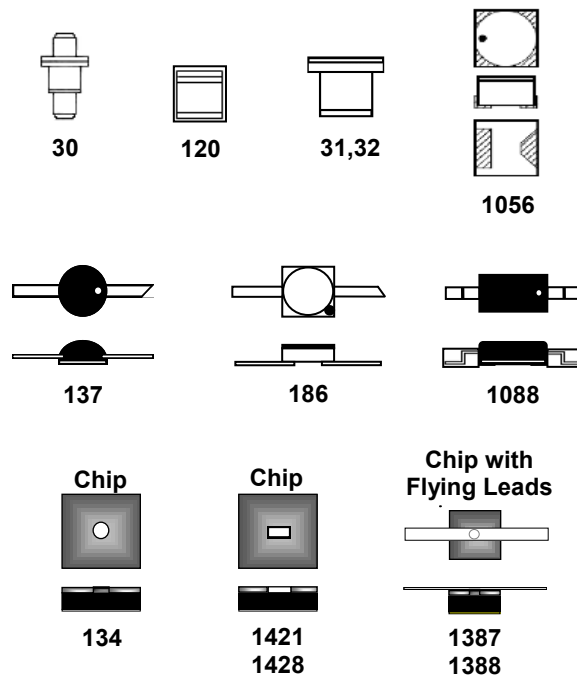

1. Packages not to size, dimensions can be found on the MACOM website.

Chip Outlines²



ODS	Dimension	mils	mm
134, 1421, 1428	A (squared)	15 ±2	0.381 ±0.51
	B	7 ±1 ²	0.178 ±0.025

2. For the MADL-000301-01340W, MADL-000301-13870G, MA4L401-134 and MADL-000401-13870G, "B" dimension, is 10 ±1 mils.

Electrical Specifications: $T_A = 25^\circ\text{C}$

Gold Doped Die

Part Number	V_B^3 (10 μA)	C_J @ 10 V ⁴ (1 MHz)		C_J @ 0 V (1 MHz)	R_S @ 10 mA ⁵ (500 MHz)	Carrier Lifetime ⁵ $I_F = +10 \text{ mA}$ $I_R = -6 \text{ mA}$	I-Region Thickness	Contact Diameter	CW Thermal Resistance ⁵
	Min./Max.	Typ.	Max.	Typ.	Max.	Nominal Characteristics			
	V	pF	pF	pF	Ohms	ns	μm	mils	$^\circ\text{C/W}$
MA4L011-134	15/35	0.13	0.18	0.18	2.10	10	2	1.2	35
MA4L021-134	20/35	0.11	0.16	0.20	2.10	10	2	1.2	35
MA4L022-134	20/35	0.12	0.17	0.19	2.00	10	2	1.2	35
MA4L031-134	30/50	0.14	0.20	0.21	2.00	20	3	1.4	34
MA4L032-134	30/50	0.12	0.18	0.20	2.50	15	3	1.5	34
MA4L062-134	60/75	0.08	0.11	0.15	2.50	10	4	1.5	33
MADL-011009-01340W	20/35	0.15	0.20	0.23	1.50	10	2	3.0	35
MADL-011010-01340W	30/50	0.15	0.21	0.24	1.50	15	3	3.0	34
MADL-011011-01340W	60/75	0.10	0.13	0.17	2.30	10	4	3.0	33
MADL-011021-14210G	20/35	0.18	0.23	0.24	2.00	10	2	2.6 x 5.8	35

Non Gold Doped Die

Part Number	V_B^3 (10 μA)	C_J @ 10 V ⁴ (1 MHz)		C_J @ 0 V (1 MHz)	R_S @ 10 mA ⁵ (500 MHz)	Carrier Lifetime ⁵ $I_F = +10 \text{ mA}$ $I_R = -6 \text{ mA}$	I-Region Thickness	Contact Diameter	CW Thermal Resistance ⁵
	Min./Max.	Typ.	Max.	Typ.	Max.	Nominal Characteristics			
	V	pF	pF	pF	Ohms	ns	μm	mils	$^\circ\text{C/W}$
MA4L101-134	100/175	0.07	0.11	0.15	2.00	90	13	3.5	25
MA4L401-134	250/300	0.19	0.22	0.25	1.20	800	25	4.5	16
MADL-000301-01340W	200/300	0.11	0.16	0.20	1.50	200	20	3.0	39
MADL-011052-14280W	20/40	0.16	0.19	0.21	2.0	23	2	2.6 x 5.8	36
MADL-011054-01340W	60/80	0.11	0.15	0.16	1.6	74	4	1.1	38

- Maximum breakdown voltage is sample tested and guaranteed by design. Exceeding this maximum V_B value may damage the device.
- Junction capacitance is measured at 1 MHz @ -10 V reverse voltage. C_{J10} @ 1 MHz represents the microwave C_J @ frequency >50 MHz at 0 V.
- Test performed with the chip bonded into a ceramic pill package. For thermal resistance package is mounted to an infinite heatsink. Chip only CW value is approximately 2°C/W lower.

Nominal High Signal Performance⁶:

Freq. = 9.4 GHz, T_A = 25°C, Pulse Width = 1 μs, Duty Cycle = 0.1%

Gold Doped Die

Part Number	Incident Peak Power			Recovery Time	Incident Peak Power	CW Input Power
	1 dB Limiting	10 dB Limiting	15 dB Limiting	3 dB Peak Power = 50 W	Maximum	Maximum
	dBm			ns	Watts	Watts
MA4L011-134	7	30	40	10	80	2
MA4L021-134	8	31	41	15	90	3
MA4L022-134	8	31	41	15	90	3
MA4L031-134	10	33	43	25	125	4
MA4L032-134	11	34	44	25	125	4
MA4L062-134	15	38	50	75	200	5
MADL-011009-01340W	8	31	41	10	90	3
MADL-011010-01340W	11	34	44	25	125	4
MADL-011011-01340W	15	38	50	75	200	5
MADL-011021-14210G	8	31	41	10	90	3

Non Gold Doped Die

Part Number	Incident Peak Power			Recovery Time	Incident Peak Power	CW Input Power
	1 dB Limiting	10 dB Limiting	15 dB Limiting	3 dB Peak Power = 50 W	Maximum	Maximum
	dBm			ns	dBm	dBm
MA4L101-134	20	45	53	100	54	38.0
MA4L401-134	30	52	60	250	60	40.0
MADL-000301-01340W	23	46	57	50	57	38.5
MADL-011052-14280W	7	28	39	50	50	36.0
MADL-011054-01340W	13	37	48	100	53	38.0

6. Measured in a single shunt diode (die) configuration attached directly to the gold plated RF ground of a 50 Ω, SMA connectorized, test fixture using 1 mil thick conductive silver epoxy. Chip anode contact is thermo-compression wire bonded using a 1 mil. diameter gold wire onto a 7.2 mil thick Rogers 5880 Duroid microstrip trace. A shunt coil provides the DC return.

Absolute Maximum Ratings⁷ T_A = +25°C

Parameter	Absolute Maximum
Forward Current	100 mA
RF Peak & CW Incident Power	Per Performance Table
Junction Temperature ⁸	+175°C
Operating Temperature	-55°C to +125°C
Storage Temperature	-55°C to +150°C
Mounting Temperature	+320°C for 10 sec.

7. Exceeding any one or combination of these limits may cause permanent damage to this device.

8. Maintaining diode junction $\leq +175^\circ\text{C}$ will ensure MTBF $>1 \text{ E}+6$ hrs for silicon devices.

Typical High Signal Peak Power Performance for a Single Shunt in a 50 Ω Circuit Frequency = 9.4 GHz, Pulse Width = 1 μs , Duty Cycle = 0.1%



Application Circuits

Typical 60 dBm Peak Power, 1 μ s P.W., 0.1% Duty Cycle, 20 dBm Flat Leakage Limiter Circuit



Typical 50 dBm Peak Power, 1 μ s P.W., 0.1% Duty Cycle, 20 dBm Flat Leakage Limiter Circuit



Notes for Specification and Nominal High Signal Performance Tables:

Maximum Series Resistance: R_S is measured at 500 MHz in the ODS-30 package and is equivalent to the total diode resistance: $R_S = R_J$ (Chip Junction Resistance) + R_O (Package Ohmic Resistance).

Maximum High Signal Performance: Test freq.= 9.4 GHz, RF pulse width = 1 μ s, Duty Cycle = 0.1%. Measured with a single shunt diode (die) attached directly to the gold plated RF housing ground with 1 mil thick conductive silver epoxy in a 50 Ω , SMA, connectorized test fixture. Chip anode contact is thermo-compression wire bonded using a 1 mil. diameter gold wire onto a 7.2 mil thick Rogers 5880 Duroid microstrip trace. A shunt coil provides the DC return and DC blocks are on the RF Input and Output.

Maximum CW Incident Power: Measured in a 50 Ω , SMA, connectorized housing @ 4 GHz utilizing a TWT amplifier and the same single diode assembly configuration as stated above.

Die Handling and Mounting Information

Handling: All semiconductor chips should be handled with care in order to avoid damage or contamination from particulates, salts, and skin oils. For individual die, the use of plastic tipped tweezers or vacuum pick up tools is strongly recommended. Bulk handling should ensure that abrasion and mechanical shock are minimized.

Die Attach: The die have Ti-Pt-Au back and anode metal, with a final gold thickness of 1 μ m. Die can be mounted with a gold-tin, eutectic solder perform or conductive silver epoxy. The metal RF and DC ground plane mounting surface must be free of contamination and should have a surface flatness of $< \pm 2$ mils.

- **Eutectic Die Attachment Using Hot Gas Die Bonder:** An 80/20, gold/tin eutectic solder perform is recommended with a work surface temperature of 255°C and a tool tip temperature of 220°C. When the hot gas is applied, the temperature at the tool tip should be approximately 290°C. The chip should not be exposed to a temperatures in excess of 320°C for more than 10 seconds.
- **Eutectic Die Attachment Using Reflow Oven:** Refer to [Application Note M538](#), "Surface Mounting Instructions".
- **Epoxy Die Attachment:** A thin, controlled amount of electrically conductive silver epoxy should be applied, approximately 1-2 mils thick to minimize ohmic and thermal resistances. A small epoxy fillet should be visible around the outer perimeter of the chip after placement to ensure full area coverage. Cure the conductive silver epoxy per the manufacturer's schedule, typically 150°C for 1 hour.

Wire Bonding: The chip's top contact (anode) metallization layer is comprised of Ti/Pt/Au with a final gold thickness of 1 μ m. Thermo-compression wedge bonding using a 0.7 or 1 mil diameter gold wire is recommended. The heat stage temperature should be set to approximately 200°C with a tool tip temperature of 125°C and a force of 18 to 40 grams. Use of ultrasonic energy is not advised but if necessary should be adjusted to the minimum setting required to achieve a good bond. Excessive energy or force applied to the top contact will cause the metallization to dislodge and lift off. Automatic ball bonding may also be used.

See [Application Note M541](#), "Bonding and Handling Procedures for Chip Diode Devices" for more detailed handling and assembly information.

Part Numbering and Ordering Information

When ordering : Use the base part number followed by a dash plus the desired package style suffix or base part only as defined in Table I “Available Case Styles” below.

For example: The MA4L011 in the 186 style package becomes MA4L011-186 or for just the chip MA4L011-134.

Table I Available Case Styles

Base Part	Available Package Styles ⁹
MA4L011	30, 31, 32, 134 (chip), 137,186, 1056, 1088
MA4L021	31, 120, 134 (chip), 1056
MA4L022	30, 32, 120, 134 (chip), 137, 186, 1056
MA4L031	31, 134 (chip), 186, 1056
MA4L032	31, 32, 134 (chip), 186, 1056
MA4L062-134	Base part (134 chip)
MA4L101	30, 134 (chip), 186
MA4L301	Base Part (MADL-000301-01340W) 31, 1056
MA4L401	30, 31, 120,134 (chip), 1056, MADL-000401-01320G for die in Gel-pack
MADL-000011-13880G	Base part (MA4L011-134 chip with flying leads)
MADL-000031-13880G	Base part (MA4L031-134 chip with flying leads)
MADL-000032-003000	Base part (MA4L032 chip in 30 package)
MADL-000062-105600	Base part (MA4L062 chip in 1056 package)
MADL-000062-13880G	Base part (MA4L062-134 chip with flying leads)
MADL-000101-13880G	Base part (MA4L101-134 chip with flying leads)
MADL-000301-01340W	Base part (134 chip)
MADL-000301-13870G	Base part (MADL-000301-01340W chip with flying leads)
MADL-000401-13870G	Base part (MA4L401-134 chip with flying leads)
MADL-011009-01340W	Base part (134 chip)
MADL-011010-01340W	Base part (134 chip), In Waffle pack, MADL-011010-01340G for Gel pack
MADL-011011-01340W	Base part (134 chip) In Waffle pack, MADL-011011-01340G for Gel pack
MADL-011021-14210G	Chip with rectangular contact (MADL-011021-1421WR wafer on ring frame)
MADL-011052-14280W	Chip with rectangular contact
MADL-011054-01340W	Base part (134 chip)

9. See Table 2 Associated Package Parasitics.

Table 2 Associated Package Parasitics

Package Style	Package Description	Nominal	
		C _{PKG} pF	L _S nH
30	Ceramic Pill	0.18	0.60
31	Ceramic Pill	0.18	0.60
32	Ceramic Pill	0.30	0.40
120	Ceramic Pill	0.13	0.40
134	Chip	—	—
137	Epoxy Encapsulated Ceramic Surface Mount with Leads	0.14	0.70
186	Ceramic Surface Mount with Leads	0.15	0.70
1056	Ceramic Surface Mount with Wrap Around Contacts	0.20	0.70
1088	Epoxy Encapsulated Ceramic Surface Mount with Leads	0.12	0.70
1387	Chip with Flying Leads	—	—
1388	Chip with Flying Leads	—	—
1421	Chip with Rectangular Contact	—	—
1428	Chip with Rectangular Contact and BCB overlay	—	—



MACOM Technology Solutions Inc. All rights reserved.

Information in this document is provided in connection with MACOM Technology Solutions Inc ("MACOM") products. These materials are provided by MACOM as a service to its customers and may be used for informational purposes only. Except as provided in MACOM's Terms and Conditions of Sale for such products or in any separate agreement related to this document, MACOM assumes no liability whatsoever. MACOM assumes no responsibility for errors or omissions in these materials. MACOM may make changes to specifications and product descriptions at any time, without notice. MACOM makes no commitment to update the information and shall have no responsibility whatsoever for conflicts or incompatibilities arising from future changes to its specifications and product descriptions. No license, express or implied, by estoppel or otherwise, to any intellectual property rights is granted by this document.

THESE MATERIALS ARE PROVIDED "AS IS" WITHOUT WARRANTY OF ANY KIND, EITHER EXPRESS OR IMPLIED, RELATING TO SALE AND/OR USE OF MACOM PRODUCTS INCLUDING LIABILITY OR WARRANTIES RELATING TO FITNESS FOR A PARTICULAR PURPOSE, CONSEQUENTIAL OR INCIDENTAL DAMAGES, MERCHANTABILITY, OR INFRINGEMENT OF ANY PATENT, COPYRIGHT OR OTHER INTELLECTUAL PROPERTY RIGHT. MACOM FURTHER DOES NOT WARRANT THE ACCURACY OR COMPLETENESS OF THE INFORMATION, TEXT, GRAPHICS OR OTHER ITEMS CONTAINED WITHIN THESE MATERIALS. MACOM SHALL NOT BE LIABLE FOR ANY SPECIAL, INDIRECT, INCIDENTAL, OR CONSEQUENTIAL DAMAGES, INCLUDING WITHOUT LIMITATION, LOST REVENUES OR LOST PROFITS, WHICH MAY RESULT FROM THE USE OF THESE MATERIALS.

MACOM products are not intended for use in medical, lifesaving or life sustaining applications. MACOM customers using or selling MACOM products for use in such applications do so at their own risk and agree to fully indemnify MACOM for any damages resulting from such improper use or sale.



Компания «ЭлектроПласт» предлагает заключение долгосрочных отношений при поставках импортных электронных компонентов на взаимовыгодных условиях!

Наши преимущества:

- Оперативные поставки широкого спектра электронных компонентов отечественного и импортного производства напрямую от производителей и с крупнейших мировых складов;
- Поставка более 17-ти миллионов наименований электронных компонентов;
- Поставка сложных, дефицитных, либо снятых с производства позиций;
- Оперативные сроки поставки под заказ (от 5 рабочих дней);
- Экспресс доставка в любую точку России;
- Техническая поддержка проекта, помощь в подборе аналогов, поставка прототипов;
- Система менеджмента качества сертифицирована по Международному стандарту ISO 9001;
- Лицензия ФСБ на осуществление работ с использованием сведений, составляющих государственную тайну;
- Поставка специализированных компонентов (Xilinx, Altera, Analog Devices, Intersil, Interpoint, Microsemi, Aeroflex, Peregrine, Syfer, Eurofarad, Texas Instrument, Miteq, Cobham, E2V, MA-COM, Hittite, Mini-Circuits, General Dynamics и др.);

Помимо этого, одним из направлений компании «ЭлектроПласт» является направление «Источники питания». Мы предлагаем Вам помощь Конструкторского отдела:

- Подбор оптимального решения, техническое обоснование при выборе компонента;
- Подбор аналогов;
- Консультации по применению компонента;
- Поставка образцов и прототипов;
- Техническая поддержка проекта;
- Защита от снятия компонента с производства.



Как с нами связаться

Телефон: 8 (812) 309 58 32 (многоканальный)

Факс: 8 (812) 320-02-42

Электронная почта: org@eplast1.ru

Адрес: 198099, г. Санкт-Петербург, ул. Калинина, дом 2, корпус 4, литера А.