

MAX3636

Low-Jitter, Wide Frequency Range, Programmable Clock Generator with 10 Outputs

General Description

The MAX3636 is a highly flexible, precision phase-locked loop (PLL) clock generator optimized for the next generation of network equipment that demands low-jitter clock generation and distribution for robust high-speed data transmission. The device features subpicosecond jitter generation, excellent power-supply noise rejection, and pin-programmable LVDS/LVPECL output interfaces. The MAX3636 provides nine differential outputs and one LVCMOS output, divided into three banks. The frequency and output interface of each output bank can be individually programmed, making this device an ideal replacement for multiple crystal oscillators and clock distribution ICs on a system board, saving cost and space.

This 3.3V IC is available in a 7mm x 7mm, 48-pin TQFN package and operates from -40°C to +85°C.

Applications

Ethernet Switches/
Routers

PCIe®, Network
Processors

Wireless Base Stations

Fibre Channel SAN

SONET/SDH Line Cards

Features

- ◆ **Inputs**
 - ◇ **Crystal Interface: 18MHz to 33.5MHz**
 - ◇ **LVCMOS Input: 15MHz to 160MHz**
 - ◇ **Differential Input: 15MHz to 350MHz**
- ◆ **Outputs**
 - ◇ **LVCMOS Output: Up to 160MHz**
 - ◇ **LVPECL/LVDS Outputs: Up to 800MHz**
- ◆ **Three Individual Output Banks**
 - ◇ **Pin-Programmable Dividers**
 - ◇ **Pin-Programmable Output Interface**
- ◆ **Wide VCO Tuning Range (3.60GHz to 4.025GHz)**
- ◆ **Low Phase Jitter**
 - ◇ **0.34ps_{RMS} (12kHz to 20MHz)**
 - ◇ **0.14ps_{RMS} (1.875MHz to 20MHz)**
- ◆ **Excellent Power-Supply Noise Rejection**
- ◆ **-40°C to +85°C Operating Temperature Range**
- ◆ **3.3V Supply**

[Ordering Information](#) appears at end of data sheet.

Functional Diagram

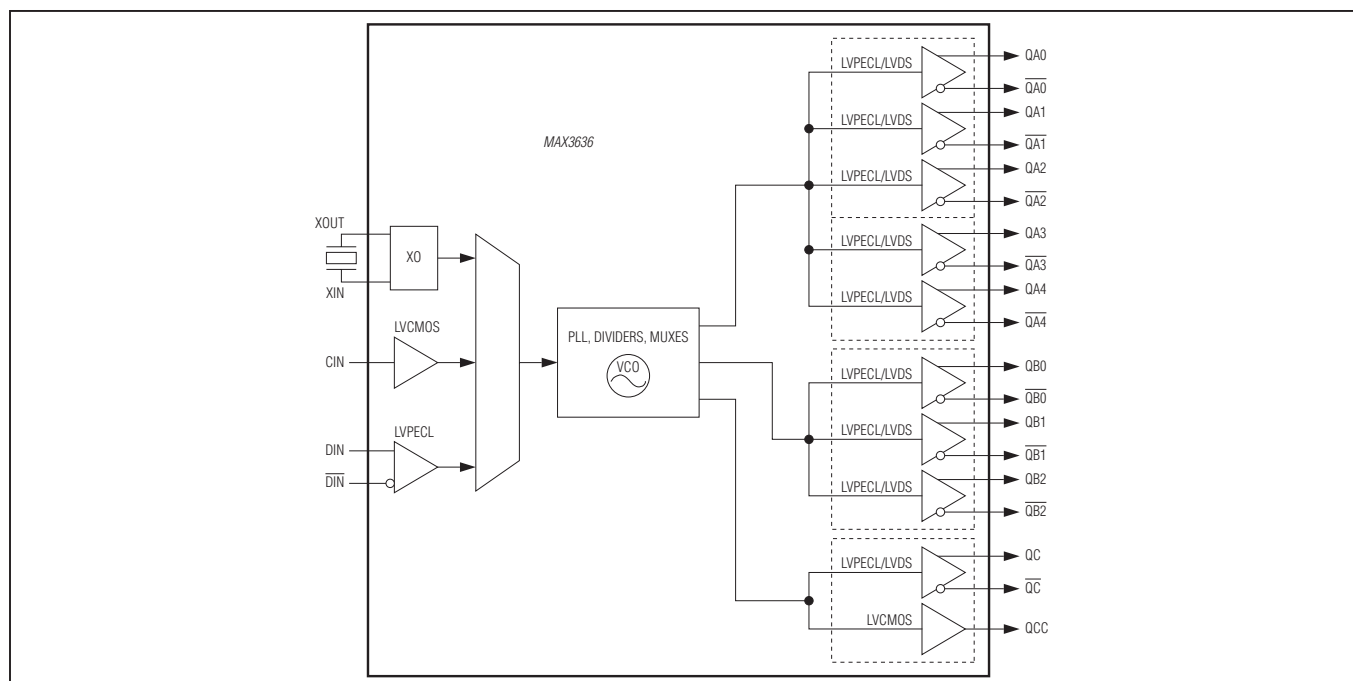

PCIe is a registered trademark of PCI-SIG Corp.

Low-Jitter, Wide Frequency Range, Programmable Clock Generator with 10 Outputs

ABSOLUTE MAXIMUM RATINGS

Supply Voltage Range (V_{CC} , V_{CCA} , V_{CCQA} , V_{CCQB} , V_{CCQC} , V_{CCQCC}).....	-0.3V to +4.0V	Current into QA[4:0], \overline{QA} [4:0], QB[2:0], \overline{QB} [2:0], QC, \overline{QC} when LVPECL Output.....	-56mA
Voltage Range at CIN, IN_SEL, DM, DF[1:0], DP[1:0], PLL_BP, DA[1:0], DB[1:0], DC[1:0], QA_CTRL1, QA_CTRL2, QB_CTRL, QC_CTRL, QCC	-0.3V to ($V_{CC} + 0.3V$)	Current into QCC.....	$\pm 50mA$
Voltage Range at DIN, \overline{DIN}	($V_{CC} - 2.35V$) to ($V_{CC} - 0.35V$)	Voltage Range at XIN.....	-0.3V to +1.2V
Voltage Range at QA[4:0], \overline{QA} [4:0], QB[2:0], \overline{QB} [2:0], QC, \overline{QC} when LVDS Output ..	-0.3V to ($V_{CC} + 0.3V$)	Voltage Range at XOUT.....	-0.3V to ($V_{CC} - 0.6V$)
		Continuous Power Dissipation ($T_A = +70^\circ C$)	
		TQFN (derate 40mW/ $^\circ C$ above +70 $^\circ C$).....	3200mW
		Operating Junction Temperature Range	-55 $^\circ C$ to +150 $^\circ C$
		Storage Temperature Range.....	-65 $^\circ C$ to +160 $^\circ C$

Stresses beyond those listed under "Absolute Maximum Ratings" may cause permanent damage to the device. These are stress ratings only, and functional operation of the device at these or any other conditions beyond those indicated in the operational sections of the specifications is not implied. Exposure to absolute maximum rating conditions for extended periods may affect device reliability.

ELECTRICAL CHARACTERISTICS

($V_{CC} = 3.0V$ to $3.6V$, $T_A = -40^\circ C$ to $+85^\circ C$. Typical values are at $V_{CC} = 3.3V$, $T_A = +25^\circ C$, unless otherwise noted. Signal applied to CIN or DIN/ \overline{DIN} only when selected as the reference clock.) (Notes 1, 2)

PARAMETER	SYMBOL	CONDITIONS	MIN	TYP	MAX	UNITS
Supply Current with PLL Enabled (Note 3)	I_{CC}	Configured with LVPECL outputs		170	215	mA
		Configured with LVDS outputs		290	365	
Supply Current with PLL Bypassed (Note 3)		Configured with LVPECL outputs		110		mA
		Configured with LVDS outputs		230		
LVCMOS/LVTTL CONTROL INPUTS (IN_SEL, DM, DF[1:0], DA[1:0], DB[1:0], DC[1:0], PLL_BP, DP[1:0], QA_CTRL1, QA_CTRL2, QB_CTRL, QC_CTRL)						
Input High Voltage	V_{IH}		2.0			V
Input Low Voltage	V_{IL}				0.8	V
Input High Current	I_{IH}	$V_{IN} = V_{CC}$			80	μA
Input Low Current	I_{IL}	$V_{IN} = 0V$	-80			μA
LVCMOS/LVTTL CLOCK INPUT (CIN)						
Reference Clock Input Frequency	f_{REF}		15		160	MHz
Input Amplitude Range		Internally AC-coupled (Note 4)	1.2		3.6	V_{P-P}
Input High Current	I_{IH}	$V_{IN} = V_{CC}$			80	μA
Input Low Current	I_{IL}	$V_{IN} = 0V$	-80			μA
Reference Clock Input Duty Cycle			40		60	%
Input Capacitance				1.5		pF
DIFFERENTIAL CLOCK INPUT (DIN, \overline{DIN}) (Note 5)						
Differential Input Frequency	f_{REF}		15		350	MHz
Input Bias Voltage	V_{CMI}		$V_{CC} - 1.8$	$V_{CC} - 1.3$		V
Input Differential Voltage Swing			150		1800	mV $_{P-P}$

Low-Jitter, Wide Frequency Range, Programmable Clock Generator with 10 Outputs

ELECTRICAL CHARACTERISTICS (continued)

($V_{CC} = 3.0V$ to $3.6V$, $T_A = -40^{\circ}C$ to $+85^{\circ}C$. Typical values are at $V_{CC} = 3.3V$, $T_A = +25^{\circ}C$, unless otherwise noted. Signal applied to CIN or DIN/ \overline{DIN} only when selected as the reference clock.) (Notes 1, 2)

PARAMETER	SYMBOL	CONDITIONS	MIN	TYP	MAX	UNITS
Single-Ended Voltage Range			$V_{CC} - 2.0$		$V_{CC} - 0.7$	V
Input Differential Impedance			80	100	120	Ω
Differential Input Capacitance				1.5		pF
LVDS OUTPUTS (QA[4:0], \overline{QA}[4:0], QB[2:0], \overline{QB}[2:0], QC, \overline{QC}) (Note 6)						
Output Frequency					800	MHz
Output High Voltage	V_{OH}				1.475	V
Output Low Voltage	V_{OL}		0.925			V
Differential Output Voltage	$ V_{OD} $		250		400	mV
Change in Magnitude of Differential Output for Complementary States	$\Delta V_{OD} $				25	mV
Output Offset Voltage	V_{OS}		1.125		1.3	V
Change in Magnitude of Output Offset Voltage for Complementary States	$\Delta V_{OS} $				25	mV
Differential Output Impedance			78	100	140	Ω
Output Current		Short together		3		mA
		Short to ground		6		
Output Current When Disabled		$V_{Q_} = \overline{V_{Q_}} = 0V$ to V_{CC}		10		μA
Output Rise/Fall Time		20% to 80%		160	240	ps
Output Duty-Cycle Distortion		PLL enabled	48	50	52	%
		PLL bypassed (Note 7)		50		
LVPECL OUTPUTS (QA[4:0], \overline{QA}[4:0], QB[2:0], \overline{QB}[2:0], QC, \overline{QC}) (Note 8)						
Output Frequency					800	MHz
Output High Voltage	V_{OH}		$V_{CC} - 1.13$	$V_{CC} - 0.98$	$V_{CC} - 0.83$	V
Output Low Voltage	V_{OL}		$V_{CC} - 1.85$	$V_{CC} - 1.70$	$V_{CC} - 1.55$	V
Output-Voltage Swing (Single-Ended)			0.5	0.7	0.9	V_{P-P}
Output Current When Disabled		$V_{Q_} = \overline{V_{Q_}} = 0V$ to V_{CC}		10		μA
Output Rise/Fall Time		20% to 80%		140	240	ps
Output Duty-Cycle Distortion		PLL enabled	48	50	52.1	%
		PLL bypassed (Note 7)		50		

Low-Jitter, Wide Frequency Range, Programmable Clock Generator with 10 Outputs

ELECTRICAL CHARACTERISTICS (continued)

($V_{CC} = 3.0V$ to $3.6V$, $T_A = -40^{\circ}C$ to $+85^{\circ}C$. Typical values are at $V_{CC} = 3.3V$, $T_A = +25^{\circ}C$, unless otherwise noted. Signal applied to CIN or DIN/ \overline{DIN} only when selected as the reference clock.) (Notes 1, 2)

PARAMETER	SYMBOL	CONDITIONS	MIN	TYP	MAX	UNITS
LVCOS/LVTTL OUTPUT (QCC)						
Output Frequency					160	MHz
Output High Voltage		$I_{OH} = -12mA$	2.6		V_{CC}	V
Output Low Voltage		$I_{OL} = 12mA$			0.4	V
Output Rise/Fall Time		20% to 80% (Note 9)	150	400	850	ps
Output Duty-Cycle Distortion		PLL enabled	42	50	58	%
		PLL bypassed (Note 7)		50		
Output Impedance				15		Ω
PLL SPECIFICATIONS						
VCO Frequency Range	f_{VCO}	Low VCO (DP1 = 0 or NC)	3600	3750	3830	MHz
		High VCO (DP1 = 1)	3830	3932	4025	
Phase-Frequency Detector Compare Frequency	f_{PFD}		15		42	MHz
PLL Jitter Transfer Bandwidth				130		kHz
Integrated Phase Jitter	RJ	25MHz crystal input (Note 9)	12kHz to 20MHz	0.34	1.0	pSRMS
			1.875MHz to 20MHz	0.14		
		25MHz LVCOS or differential input (Notes 10, 11)	0.34			
Supply-Noise Induced Phase Spur at LVPECL/LVDS Output		(Note 12)		-56		dBc
Supply-Noise Induced Phase Spur at LVCOS Output		(Note 12)		-45		dBc
Deterministic Jitter Induced by Power-Supply Noise		LVPECL or LVDS (Note 12)		6		pSP-P
Nonharmonic and Subharmonic Spurs		(Note 13)		-70		dBc
SSB Phase Noise at 491.52MHz		$f_{OFFSET} = 1kHz$		-111		dBc/Hz
		$f_{OFFSET} = 10kHz$		-113		
		$f_{OFFSET} = 100kHz$		-119		
		$f_{OFFSET} = 1MHz$		-136		
		$f_{OFFSET} \geq 10MHz$		-147		
SSB Phase Noise at 312.5MHz		$f_{OFFSET} = 1kHz$		-115		dBc/Hz
		$f_{OFFSET} = 10kHz$		-116		
		$f_{OFFSET} = 100kHz$		-122		
		$f_{OFFSET} = 1MHz$		-139		
		$f_{OFFSET} \geq 10MHz$		-149		

Low-Jitter, Wide Frequency Range, Programmable Clock Generator with 10 Outputs

ELECTRICAL CHARACTERISTICS (continued)

($V_{CC} = 3.0V$ to $3.6V$, $T_A = -40^{\circ}C$ to $+85^{\circ}C$. Typical values are at $V_{CC} = 3.3V$, $T_A = +25^{\circ}C$, unless otherwise noted. Signal applied to CIN or DIN/DIN only when selected as the reference clock.) (Notes 1, 2)

PARAMETER	SYMBOL	CONDITIONS	MIN	TYP	MAX	UNITS
SSB Phase Noise at 245.76MHz		$f_{\text{OFFSET}} = 1\text{kHz}$		-117		dBc/ Hz
		$f_{\text{OFFSET}} = 10\text{kHz}$		-119		
		$f_{\text{OFFSET}} = 100\text{kHz}$		-125		
		$f_{\text{OFFSET}} = 1\text{MHz}$		-142		
		$f_{\text{OFFSET}} \geq 10\text{MHz}$		-151		
SSB Phase Noise at 156.25MHz		$f_{\text{OFFSET}} = 1\text{kHz}$		-122		dBc/ Hz
		$f_{\text{OFFSET}} = 10\text{kHz}$		-123		
		$f_{\text{OFFSET}} = 100\text{kHz}$		-129		
		$f_{\text{OFFSET}} = 1\text{MHz}$		-145		
		$f_{\text{OFFSET}} \geq 10\text{MHz}$		-152		
SSB Phase Noise at 125MHz		$f_{\text{OFFSET}} = 1\text{kHz}$		-123		dBc/ Hz
		$f_{\text{OFFSET}} = 10\text{kHz}$		-124		
		$f_{\text{OFFSET}} = 100\text{kHz}$		-130		
		$f_{\text{OFFSET}} = 1\text{MHz}$		-147		
		$f_{\text{OFFSET}} \geq 10\text{MHz}$		-153		
SSB Phase Noise at 100MHz		$f_{\text{OFFSET}} = 1\text{kHz}$		-126		dBc/ Hz
		$f_{\text{OFFSET}} = 10\text{kHz}$		-127		
		$f_{\text{OFFSET}} = 100\text{kHz}$		-133		
		$f_{\text{OFFSET}} = 1\text{MHz}$		-148		
		$f_{\text{OFFSET}} \geq 10\text{MHz}$		-152		

Note 1: A series resistor of up to 10.5Ω is allowed between V_{CC} and V_{CCA} for filtering supply noise when system power-supply tolerance is $V_{CC} = 3.3V \pm 5\%$. See [Figure 3](#).

Note 2: Unless otherwise noted, specifications at $T_A = +25^{\circ}C$ and $T_A = +85^{\circ}C$ are guaranteed by production testing. Specifications at $T_A = -40^{\circ}C$ are guaranteed by design.

Note 3: Measured with all outputs enabled and unloaded.

Note 4: CIN can be AC- or DC-coupled. See [Figure 8](#). Input high voltage must be $\leq V_{CC} + 0.3V$.

Note 5: DIN can be AC- or DC-coupled. See [Figure 10](#).

Note 6: Measured with 100Ω differential load.

Note 7: Measured with crystal input, or with 50% duty cycle LVCMOS or differential input.

Note 8: Measured with output termination of 50Ω to $V_{CC} - 2V$ or Thevenin equivalent.

Note 9: Measured with a series resistor of 33Ω to a load capacitance of 3.0pF . See [Figure 1](#).

Note 10: Measured at 156.25MHz .

Note 11: Measured using LVCMOS/LVTTL input with slew rate $\geq 1.0\text{V/ns}$, or differential input with slew rate $\geq 0.5\text{V/ns}$.

Note 12: Measured at 156.25MHz output with 200kHz , $50\text{mV}_{\text{P-P}}$ sinusoidal signal on the supply using the crystal input and the power-supply filter shown in [Figure 3](#). See the [Typical Operating Characteristics](#) for other supply noise frequencies. Deterministic jitter is calculated from the measured power-supply-induced spurs. For more information, refer to [Application Note 4461: HFAN-04.5.5: Characterizing Power-Supply Noise Rejection in PLL Clock Synthesizers](#).

Note 13: Measured with all outputs enabled and all three banks at different frequencies.

Low-Jitter, Wide Frequency Range, Programmable Clock Generator with 10 Outputs

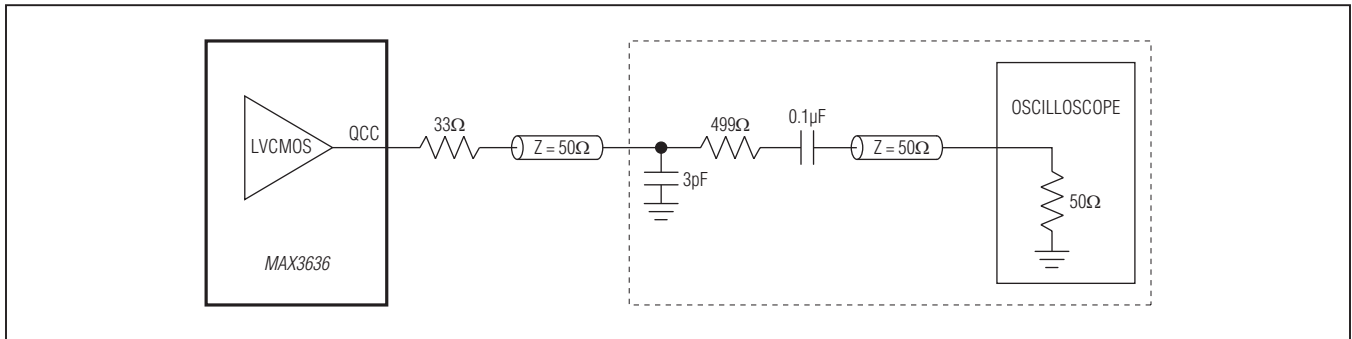
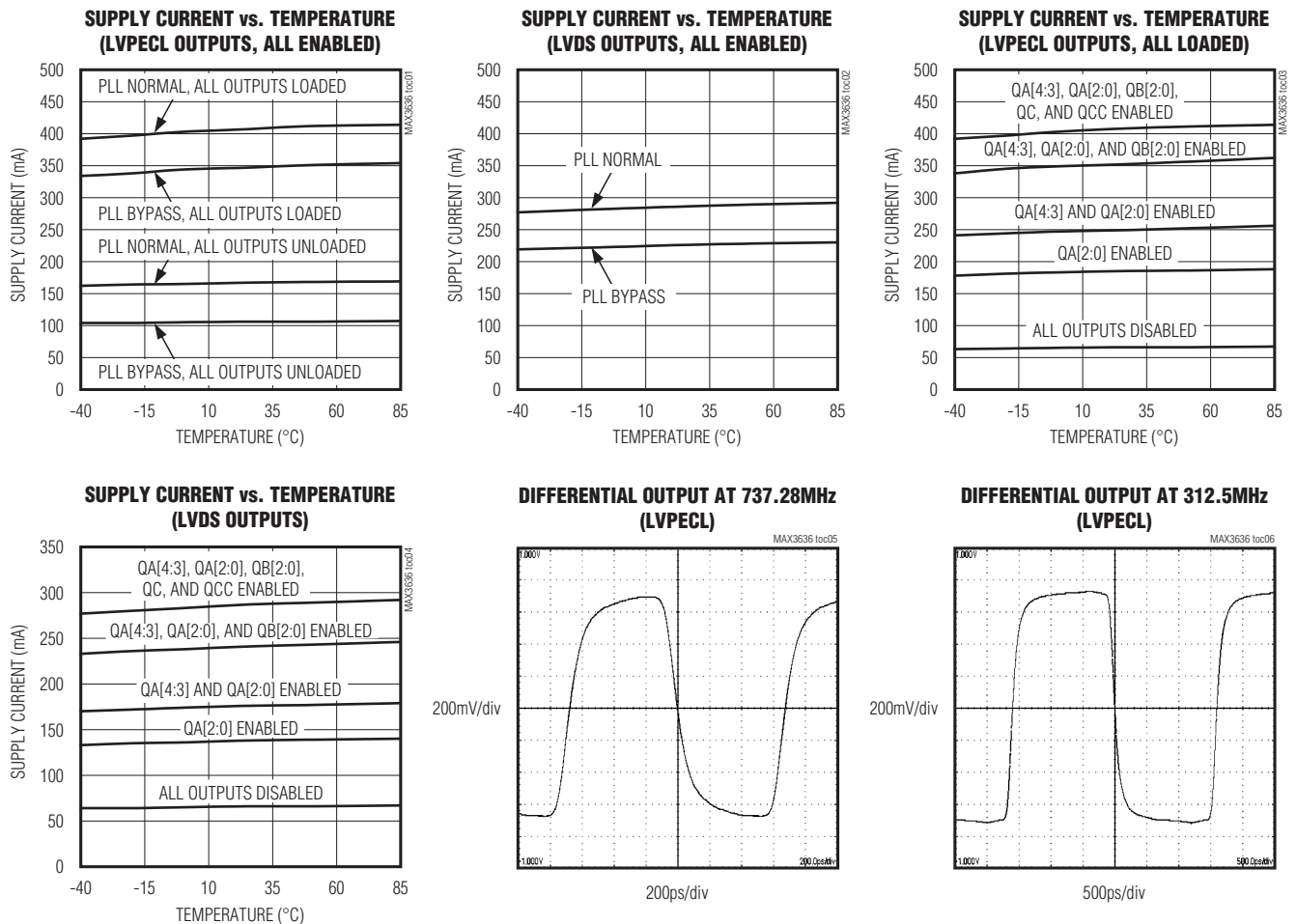

Figure 1. LVCMOS Output Measurement Setup

Typical Operating Characteristics

($V_{CC} = 3.3V$, $T_A = +25^\circ C$, unless otherwise noted.)



MAX3636

Low-Jitter, Wide Frequency Range, Programmable Clock Generator with 10 Outputs

Typical Operating Characteristics (continued)

($V_{CC} = 3.3V$, $T_A = +25^\circ C$, unless otherwise noted.)

DIFFERENTIAL OUTPUT AT 156.25MHz (LVPECL)

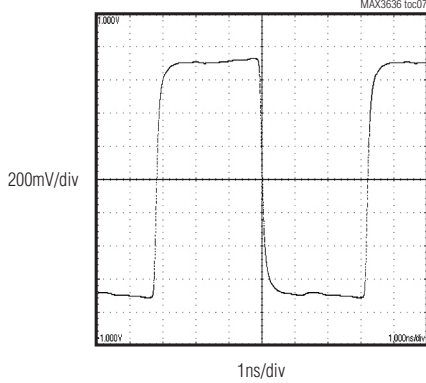

DIFFERENTIAL OUTPUT AT 156.25MHz (LVDS)

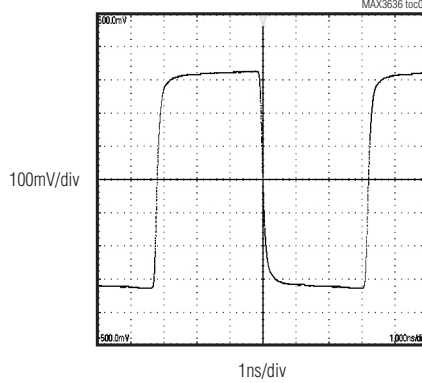

QCC OUTPUT AT 125MHz (LVCMOS)

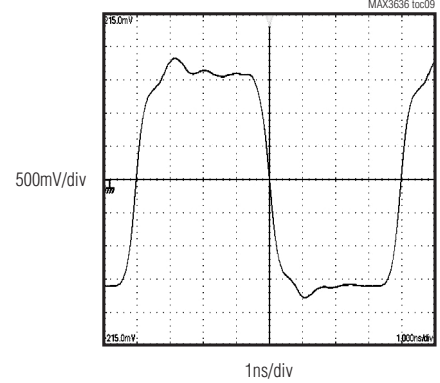

OUTPUT SWING vs. OUTPUT FREQUENCY

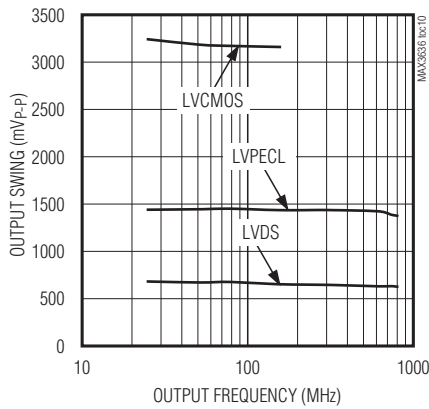

OUTPUT SWING vs. TEMPERATURE

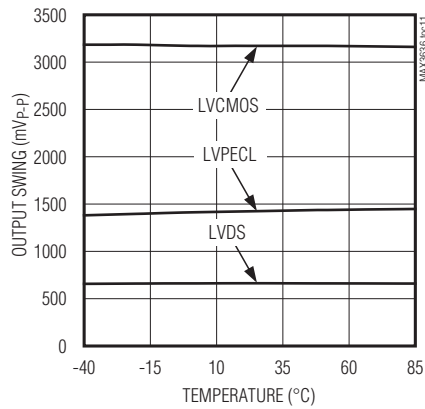

RISE/FALL TIME vs. TEMPERATURE (20% TO 80%)

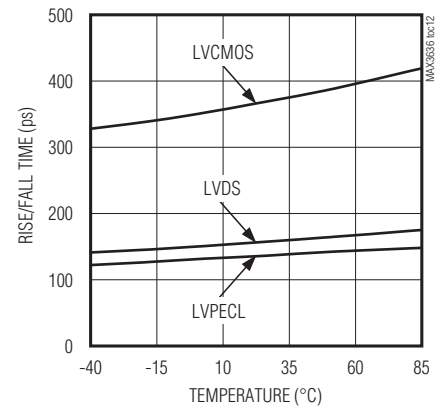

DUTY-CYCLE DISTORTION vs. TEMPERATURE

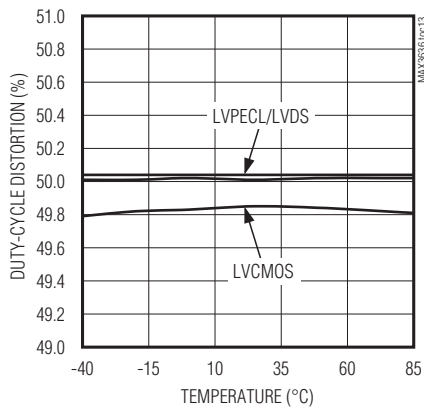

PHASE NOISE AT 622.08MHz

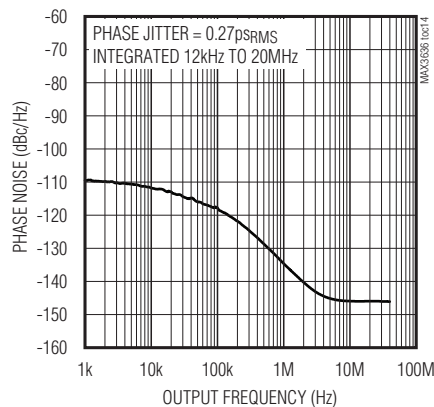

PHASE NOISE AT 491.52MHz

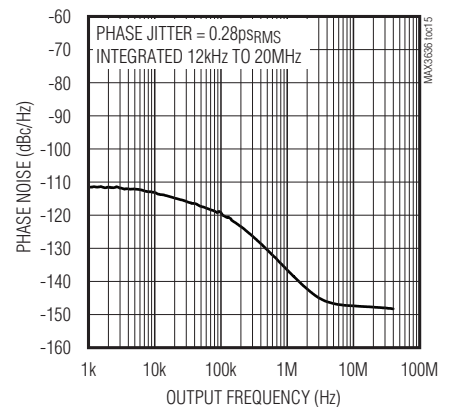

Low-Jitter, Wide Frequency Range, Programmable Clock Generator with 10 Outputs

Typical Operating Characteristics (continued)

($V_{CC} = 3.3V$, $T_A = +25^\circ C$, unless otherwise noted.)

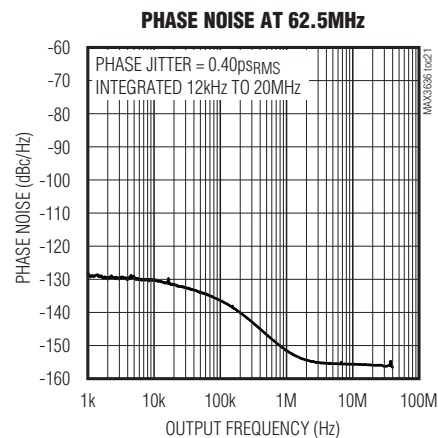
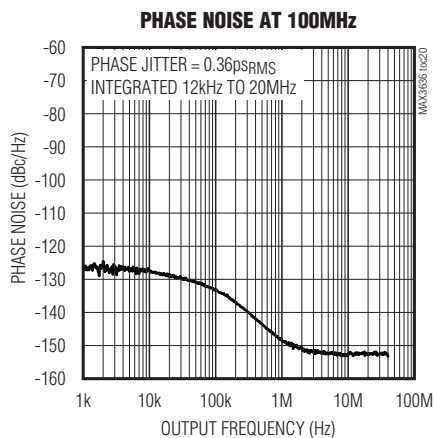
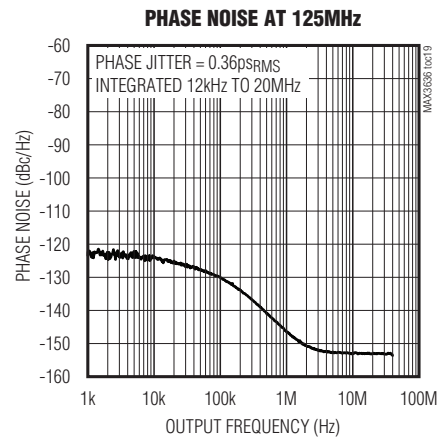
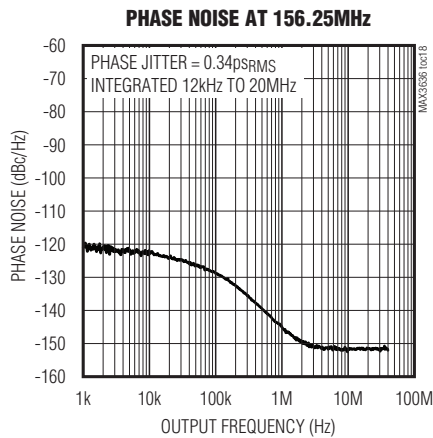
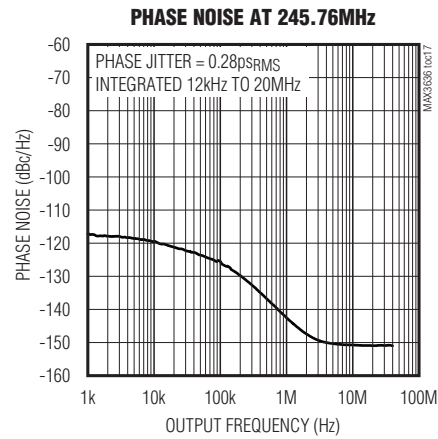
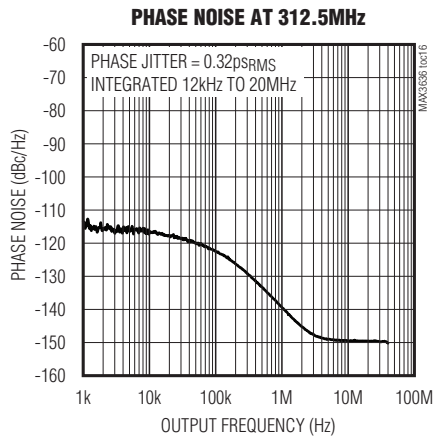

Low-Jitter, Wide Frequency Range, Programmable Clock Generator with 10 Outputs

Typical Operating Characteristics (continued)

($V_{CC} = 3.3V$, $T_A = +25^\circ C$, unless otherwise noted.)

**INTEGRATED PHASE JITTER (12kHz TO 20MHz)
vs. TEMPERATURE**

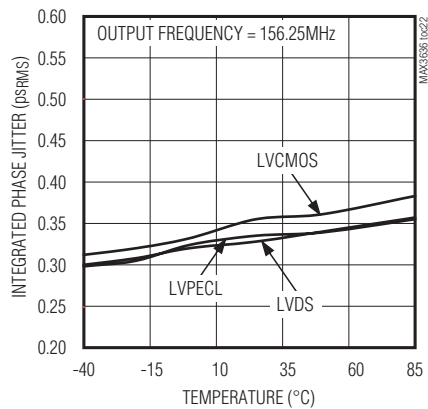

JITTER TRANSFER

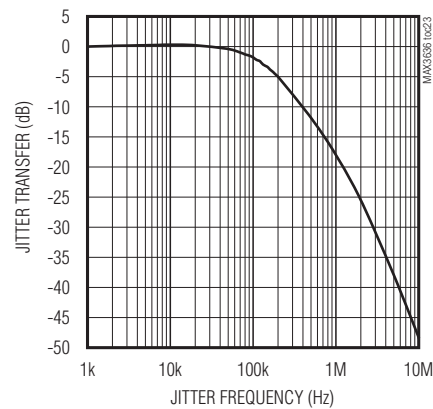

**SPURS INDUCED BY POWER-SUPPLY NOISE
vs. NOISE FREQUENCY**

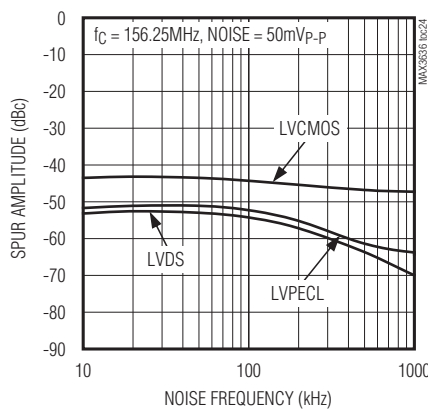

**DETERMINISTIC JITTER INDUCED BY POWER
SUPPLY NOISE vs. NOISE FREQUENCY**

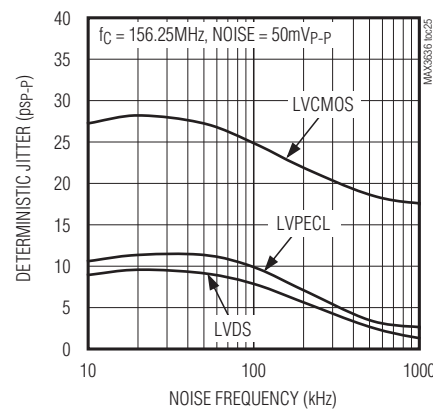

MAX3636

Low-Jitter, Wide Frequency Range, Programmable Clock Generator with 10 Outputs

Pin Configuration

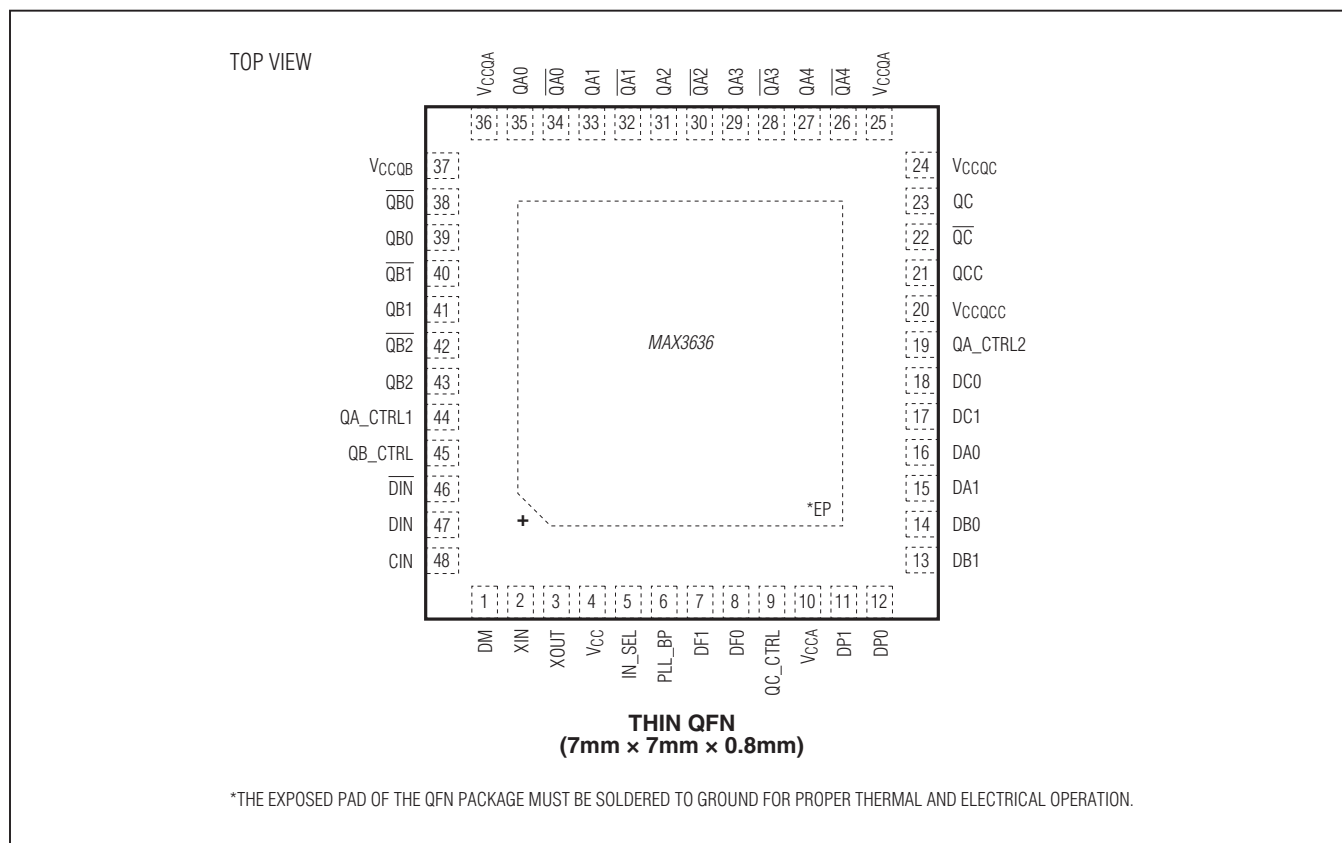

Pin Description

PIN	NAME	FUNCTION
1	DM	LVC MOS/LVTTL Input. Three-level control for input divider M. See Table 3.
2	XIN	Crystal Oscillator Input
3	XOUT	Crystal Oscillator Output
4	V _{CC}	Core Power Supply. Connect to 3.3V.
5	IN_SEL	LVC MOS/LVTTL Input. Three-level control for input mux. See Table 1.
6	PLL_BP	LVC MOS/LVTTL Input. Three-level control for PLL bypass mode. See Table 2.
7, 8	DF1, DF0	LVC MOS/LVTTL Inputs. Three-level controls for feedback divider F. See Table 4.
9	QC_CTRL	LVC MOS/LVTTL Input. Three-level control input for C-bank output interface. See Table 10.
10	V _{CCA}	Power Supply for Internal Voltage-Controlled Oscillators (VCOs). See Figure 3.
11, 12	DP1, DP0	LVC MOS/LVTTL Inputs. Three-level controls for VCO select and prescale divider P. See Table 7.
13, 14	DB1, DB0	LVC MOS/LVTTL Inputs. Three-level controls for output divider B. See Table 5.

Low-Jitter, Wide Frequency Range, Programmable Clock Generator with 10 Outputs

Pin Description (continued)

PIN	NAME	FUNCTION
15, 16	DA1, DA0	LVC MOS/LVTTL Inputs. Three-level controls for output divider A. See Table 5.
17, 18	DC1, DC0	LVC MOS/LVTTL Inputs. Three-level controls for output divider C. See Table 6.
19	QA_CTRL2	LVC MOS/LVTTL Input. Three-level control for QA[4:3] output interface. See Table 8.
20	V _{CCQCC}	Power Supply for QCC Output. Connect to 3.3V.
21	QCC	C-Bank LVC MOS Clock Output
22, 23	\overline{QC} , QC	C-Bank Differential Output. Configured as LVPECL or LVDS with the QC_CTRL pin.
24	V _{CCQC}	Power Supply for C-Bank Differential Output. Connect to 3.3V.
25, 36	V _{CCQA}	Power Supply for A-Bank Differential Outputs. Connect to 3.3V.
26, 27	$\overline{QA4}$, QA4	A-Bank Differential Output. Configured as LVPECL or LVDS with the QA_CTRL2 pin.
28, 29	$\overline{QA3}$, QA3	A-Bank Differential Output. Configured as LVPECL or LVDS with the QA_CTRL2 pin.
30, 31	$\overline{QA2}$, QA2	A-Bank Differential Output. Configured as LVPECL or LVDS with the QA_CTRL1 pin.
32, 33	$\overline{QA1}$, QA1	A-Bank Differential Output. Configured as LVPECL or LVDS with the QA_CTRL1 pin.
34, 35	$\overline{QA0}$, QA0	A-Bank Differential Output. Configured as LVPECL or LVDS with the QA_CTRL1 pin.
37	V _{CCQB}	Power Supply for B-Bank Differential Outputs. Connect to 3.3V.
38, 39	$\overline{QB0}$, QB0	B-Bank Differential Output. Configured as LVPECL or LVDS with the QB_CTRL pin.
40, 41	$\overline{QB1}$, QB1	B-Bank Differential Output. Configured as LVPECL or LVDS with the QB_CTRL pin.
42, 43	$\overline{QB2}$, QB2	B-Bank Differential Output. Configured as LVPECL or LVDS with the QB_CTRL pin.
44	QA_CTRL1	LVC MOS/LVTTL Input. Three-level control for QA[2:0] output interface. See Table 8.
45	QB_CTRL	LVC MOS/LVTTL Input. Three-level control for B-bank output interface. See Table 9.
46, 47	\overline{DIN} , DIN	Differential Clock Input. Operates up to 350MHz. This input can accept DC-coupled LVPECL signals, and is internally biased to accept AC-coupled LVDS, CML, and LVPECL signals.
48	CIN	LVC MOS Clock Input. Operates up to 160MHz.
—	EP	Exposed Pad. Connect to supply ground for proper electrical and thermal performance.

Low-Jitter, Wide Frequency Range, Programmable Clock Generator with 10 Outputs

Detailed Description

The MAX3636 is a low-jitter clock generator designed to operate over a wide range of frequencies. It consists of a selectable reference clock (on-chip crystal oscillator,

LVC MOS input, or differential input), PLL with on-chip VCO, pin-programmable dividers and muxes, and three banks of clock outputs. See Figure 2. The output banks include nine pin-programmable LVDS/LVPECL output buffers and one LVC MOS output buffer. The frequency,

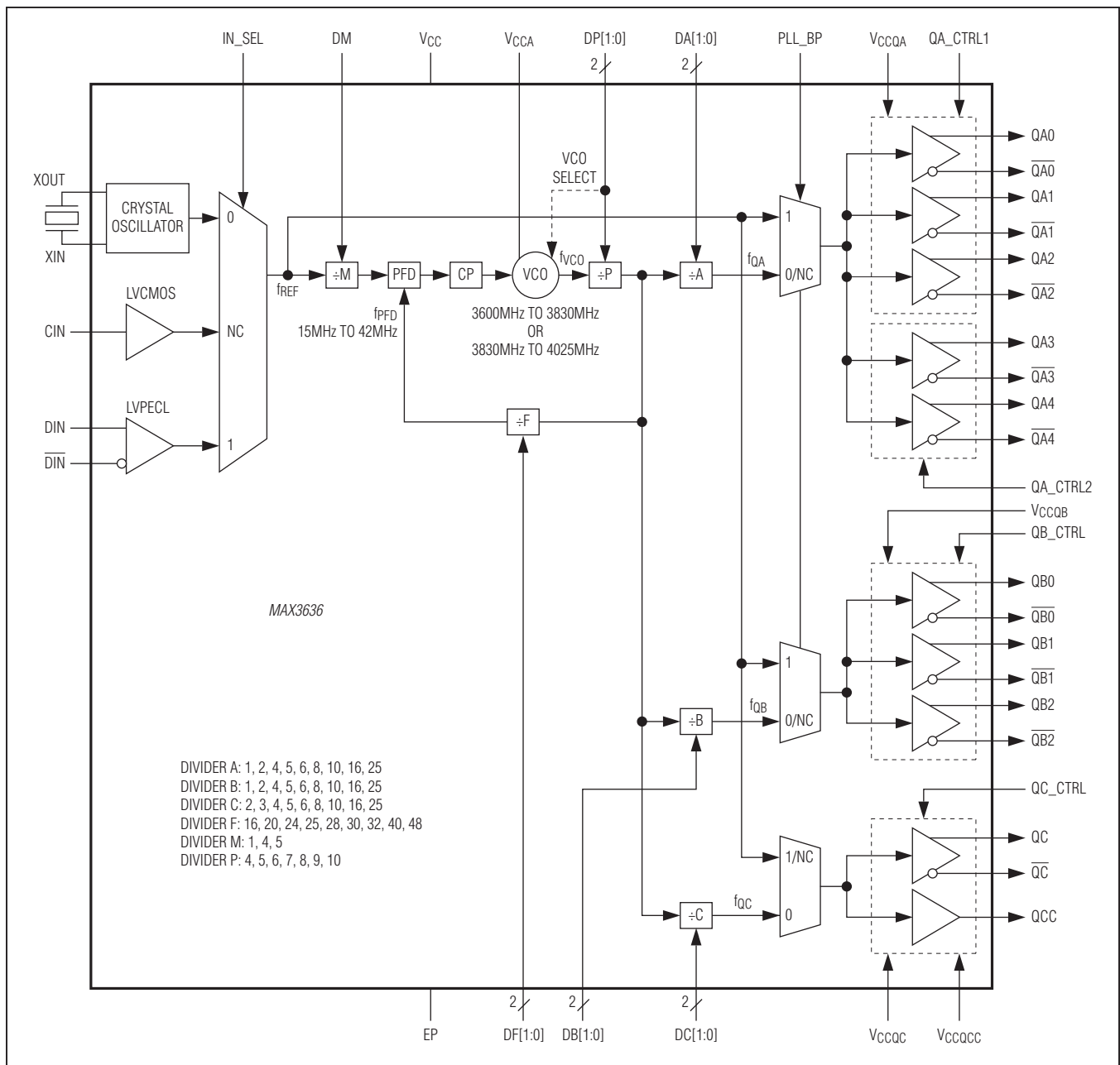

Figure 2. Detailed Functional Diagram

Low-Jitter, Wide Frequency Range, Programmable Clock Generator with 10 Outputs

enabling, and output interface of each output bank can be individually programmed. In addition the A-bank is split into two banks with programmable enabling and output interface. A PLL bypass mode is also available for system testing or clock distribution.

Crystal Oscillator

The on-chip crystal oscillator provides the low-frequency reference clock for the PLL. This oscillator requires an external crystal connected between XIN and XOUT. See the [Crystal Selection and Layout](#) section for more information. The XIN and XOUT pins can be left open if not used.

LVC MOS Clock Input

An LVC MOS-compatible clock source can be connected to CIN to serve as the PLL reference clock. The input is internally biased to allow AC- or DC-coupling (see the [Applications Information](#) section). It is designed to operate from 15MHz to 160MHz. No signal should be applied to CIN if not used.

Differential Clock Input

A differential clock source can be connected to DIN to serve as the PLL reference clock. This input operates from 15MHz to 350MHz and contains an internal 100Ω differential termination. This input can accept

DC-coupled LVPECL signals, and is internally biased to accept AC-coupled LVDS, CML, and LVPECL signals (see the [Applications Information](#) section). No signal should be applied to DIN if not used.

Phase-Locked Loop (PLL)

The PLL takes the signal from the crystal oscillator, LVC MOS clock input, or differential clock input and synthesizes a low-jitter, high-frequency clock. The PLL contains a phase-frequency detector (PFD), a charge pump (CP), and two low phase noise VCOs that combined give a wide 3.60GHz to 4.025GHz frequency range. The high-frequency VCO output is divided by prescale divider P and then is connected to the PFD input through a feedback divider F. The PFD compares the reference frequency to the divided-down VCO output and generates a control signal that keeps the VCO locked to the reference clock. The high-frequency VCO/P output clock is sent to the output dividers. To minimize noise-induced jitter, the VCO supply (V_{CCA}) is isolated from the core logic and output buffer supplies.

Dividers and Muxes

The dividers and muxes are set with three-level control inputs. Divider settings and routing information are given in [Table 1](#) to [Table 7](#). See [Table 11](#) for example divider configurations used in various applications.

Table 1. PLL Input

IN_SEL	INPUT
0	Crystal Input. XO circuit is disabled when not selected.
1	Differential Input. No signal should be applied to DIN if not selected.
NC	LVC MOS Input. No signal should be applied to CIN if not selected.

Table 2. PLL Bypass

PLL_BP	PLL OPERATION
0	PLL Enabled for Normal Operation. All outputs from the A, B, and C banks are derived from the VCO.
1	PLL Bypassed. Selected input passes directly to the outputs. Both VCOs are disabled to minimize power consumption and intermodulation spurs. Used for system testing or clock distribution.
NC	The outputs from A-bank and B-bank are derived from the VCO, but the C-bank outputs are directly driven from the input signal for purposes of daisy chaining.

Low-Jitter, Wide Frequency Range, Programmable Clock Generator with 10 Outputs

Table 3. Input Divider M

DM	M DIVIDER RATIO
0	÷1
1	÷5
NC	÷4

Note: When the on-chip XO is selected ($IN_SEL = 0$), the setting $DM = 0$ is required.

Table 4. PLL Feedback Divider F

DF1	DF0	F DIVIDER RATIO
0	0	÷25
0	1	÷20
1	0	÷16
1	1	÷32
1	NC	÷24
NC	1	÷30
0	NC	÷40
NC	0	÷48
NC	NC	÷28

Table 5. Output Divider A, B

DA1/DB1	DA0/DB0	A, B DIVIDER RATIO
0	0	÷2
0	1	÷4
1	0	÷5
1	1	÷6
1	NC	÷8
NC	1	÷10
0	NC	÷16
NC	0	÷25
NC	NC	÷1

Table 6. Output Divider C

DC1	DC0	C DIVIDER RATIO
0	0	÷2
0	1	÷3
1	0	÷4
1	1	÷5
1	NC	÷6
NC	1	÷8
0	NC	÷10
NC	0	÷16
NC	NC	÷25

Table 7. VCO Select and Prescale Divider P

DP1	DP0	VCO FREQUENCY RANGE (MHz)	P DIVIDER RATIO	(VCO/P) FREQUENCY RANGE (MHz)
0	0	Low (3600 to 3830)	÷5	720 to 766
	1		÷6	600 to 638.33
	NC		÷9	400 to 425.50
NC	0	High (3830 to 4025)	÷7	547.14 to 575
	1		÷10	383 to 402.50
	NC		÷8	478.75 to 503.12
1	0		÷4	957.50 to 1006.25
	1		÷5	766 to 805
	NC		÷6	638.33 to 670.83

Table 8. A-Bank Output Interface

QA_CTRL1	QA[2:0] OUTPUT
0	QA[2:0] = LVDS
1	QA[2:0] = LVPECL
NC	QA[2:0] disabled to high impedance
QA_CTRL2	QA[4:3] OUTPUT
0	QA[4:3] = LVDS
1	QA[4:3] = LVPECL
NC	QA[4:3] disabled to high impedance

Table 9. B-Bank Output Interface

QB_CTRL	QB[2:0] OUTPUT
0	QB[2:0] = LVDS
1	QB[2:0] = LVPECL
NC	QB[2:0] disabled to high impedance

Table 10. C-Bank Output Interface

QC_CTRL	QC AND QCC OUTPUT
0	QC = LVDS, QCC = LVCMOS
1	QC = LVPECL, QCC = LVCMOS
NC	QC and QCC disabled to high impedance

LVDS/LVPECL Clock Outputs

The differential clock outputs (QA[4:0], QB[2:0], QC) operate up to 800MHz and have a pin-programmable LVDS/LVPECL output interface. See [Table 8](#) to [Table 10](#).

Low-Jitter, Wide Frequency Range, Programmable Clock Generator with 10 Outputs

When configured as LVDS, the buffers are designed to drive transmission lines with a 100Ω differential termination. When configured as LVPECL, the buffers are designed to drive transmission lines terminated with 50Ω to V_{CC} - 2V. Unused output banks can be disabled to high impedance and unused outputs can be left open.

LVC MOS Clock Output

The LVC MOS clock output operates up to 160MHz and is designed to drive a single-ended high-impedance load. If unused, this output can be left open or the C-bank can be disabled to high impedance.

Internal Reset

During power-on, a power-on reset (POR) signal is generated to synchronize all dividers. A reset signal is also generated if any control pin is changed. Outputs within a bank are phase aligned, but outputs bank-to-bank may not be phase aligned.

Applications Information

Output Frequency Configuration

The MAX3636 output frequencies (f_{QA}, f_{QB}, f_{QC}) are functions of the reference frequency (f_{REF}) and the pin-programmable dividers (A, B, C, F, M). The relationships can be expressed as:

$$f_{QA} = \frac{f_{REF}}{M} \times \frac{F}{A} \quad (1)$$

$$f_{QB} = \frac{f_{REF}}{M} \times \frac{F}{B} \quad (2)$$

$$f_{QC} = \frac{f_{REF}}{M} \times \frac{F}{C} \quad (3)$$

The frequency ranges for the selected reference clocks are 18MHz to 33.5MHz for the crystal oscillator input, 15MHz to 160MHz for the LVC MOS input, and 15MHz to 350MHz for the differential input. The available dividers are given in [Table 3](#) to [Table 6](#).

For a given reference frequency f_{REF}, the input divider M, the PLL feedback divider F, and VCO prescale divider P must be configured so the VCO frequency (f_{VCO}) falls within the specified ranges. Invalid PLL configuration leads to VCO frequencies beyond the specified ranges and can result in loss of lock. An expression for the VCO frequency along with the specified ranges is given by:

$$f_{VCO} = \frac{f_{REF}}{M} \times F \times P \quad (4)$$

$$3600\text{MHz} \leq f_{VCO} \leq 3830\text{MHz} \quad (\text{when DP1} = 0) \quad (5)$$

$$3830\text{MHz} \leq f_{VCO} \leq 4025\text{MHz} \quad (\text{when DP1} = 1 \text{ or NC}) \quad (6)$$

The prescale divider P is set by pins DP1 and DP0 as given in [Table 7](#).

In addition, the reference clock frequency and input divider M must also be selected so the PFD compare frequency (f_{PFD}) falls within the specified range of 15MHz to 42MHz. If applicable, the higher f_{PFD} should be selected for optimal jitter performance.

$$f_{PFD} = \frac{f_{REF}}{M} = \frac{f_{VCO}}{P \times F} \quad (7)$$

$$15\text{MHz} \leq f_{PFD} \leq 42\text{MHz} \quad (8)$$

Note that the reference clock frequency is not limited by the f_{PFD} range when the PLL is in bypass mode.

Example Frequency Configuration

The following is an example of how to find divider ratios for a valid PLL configuration, given a requirement of input and output frequencies.

- 1) Select input and output frequencies for an Ethernet application.

$$f_{REF} = 25\text{MHz}$$

$$f_{QA} = 312.5\text{MHz}$$

$$f_{QB} = 156.25\text{MHz}$$

$$f_{QC} = 125\text{MHz}$$

- 2) Find the input divider M for a valid PFD compare frequency. Using [Table 3](#) and equations (7) and (8), it is determined that M = ÷1 is the only valid option.
- 3) Find the feedback divider F and prescale divider P for a valid f_{VCO}. Using [Table 4](#) and [Table 7](#) along with equations (4), (5), and (6), it is determined that F = ÷25 and P = ÷6 results in f_{VCO} = 3750MHz, which is within the valid range of the low VCO.
- 4) Find the output dividers A, B, C for the required output frequencies. Using [Table 5](#) and [Table 6](#) and equations (1), (2), and (3), it is determined that A = ÷2 gives f_{QA} = 312.5MHz, B = ÷4 gives f_{QB} = 156.25MHz, and C = ÷5 gives f_{QC} = 125MHz.

[Table 11](#) provides input and output frequencies along with valid divider ratios for a variety of applications.

Low-Jitter, Wide Frequency Range, Programmable Clock Generator with 10 Outputs

Table 11. Reference Frequencies and Divider Ratios for Various Applications

f _{REF} (MHz)	INPUT DIVIDER (M)	PLL FEEDBACK DIVIDER (F)	VCO FREQUENCY (MHz)	VCO PRESCALE DIVIDER (P)	OUTPUT DIVIDER (A, B, C)	OUTPUT FREQUENCY (MHz)	APPLICATIONS
19.44	1	32	3732.48	6	1	622.08	SONET/SDH, STM-N
38.88	1	16		6	2	311.04	
155.52	4	16		6	4	155.52	
				6	8	77.76	
				6	16	38.88	
25	1	25	3750	6	1	625	Ethernet
31.25	1	20		6	2	312.5	
62.5	4	40		6	4	156.25	
125	5	25		6	5	125	
156.25	5	20		6	10	62.5	
26.04166	1	24		6	25	25	
25	1	30	3750	5	1	750	Various
31.25	1	24		5	2	375	
62.5	4	48		5	4	187.5	
125	4	24		5	5	150	
				5	6	125	
156.25	5	24		5	10	75	
			5	25	30		
15.36	1	48	3686.4	5	1	737.28	Wireless Base Station: WCDMA, cdma2000®, LTE, TD_SCDMA, WiMAX™, GSM
30.72	1	24		5	2	368.64	
61.44	4	48		5	4	184.32	
122.88	4	24		5	6	122.88	
				5	8	92.16	
15.36	1	40	3686.4	6	1	614.4	
19.2	1	32		6	2	307.2	
30.72	1	20		6	4	153.6	
38.4	1	16		6	5	122.88	
61.44	4	40		6	6	102.4	
76.8	4	32		6	8	76.8	
122.88	4	20	6	10	61.44		
30.72	1	16	3932.16	8	1	491.52	
61.44	2	32		8	2	245.76	
				8	4	122.88	
122.88	4	16		8	8	61.44	
			8	16	30.72		

cdma2000 is a registered trademark of the Telecommunications Industry Association.

WiMAX is a trademark of WiMAX Forum.

Low-Jitter, Wide Frequency Range, Programmable Clock Generator with 10 Outputs

Table 11. Reference Frequencies and Divider Ratios for Various Applications (continued)

f_{REF} (MHz)	INPUT DIVIDER (M)	PLL FEEDBACK DIVIDER (F)	VCO FREQUENCY (MHz)	VCO PRESCALE DIVIDER (P)	OUTPUT DIVIDER (A, B, C)	OUTPUT FREQUENCY (MHz)	APPLICATIONS
26	1	16	3744	9	1	416	GSM
				9	4	104	
52	4	32		9	8	52	
				9	16	26	
26.5625	1	24	3825	6	2	318.75	FC-SAN
				6	4	159.375	
				6	6	106.25	
26.5625	1	16	3825	9	2	212.5	FC-SAN
				9	4	106.25	
				9	8	53.125	
33.3	1	24	4000	5	2	400	Server, FB-DIMM, Network Processor, DDR/QDR Memory, PCIe, SATA
133.33	4			5	4	200	
166.67	5			5	6	133.333	
25	1	32		5	8	100	
100	4			5	16	50	
125	5			4	2	500	
133.33	4	30	4	4	250		
166.67	5	40	4	5	200		
25	1		4	6	166.67		
100	4		4	8	125		
125	5	32	4	10	100		
31.25	1		4	25	40		
125	4		4000	8	2	250	
156.25	5	8		4	125		
78.125	5	8		5	100		
66.67	4	30		8	8	62.5	
				8	10	50	
66.67	4	30	8	25	20		
33.3	1		20	4000	6	2	333.33
133.33	4	6			4	166.67	
		6			5	133.33	
166.67	5	6			8	83.33	
		6			10	66.67	
32.76	1	20	3931.2	6	5	131.04	Microwave Radio Link
				6	10	65.52	

Low-Jitter, Wide Frequency Range, Programmable Clock Generator with 10 Outputs

Power-Supply Filtering

The MAX3636 is a mixed analog/digital IC. The PLL contains analog circuitry susceptible to random noise. To take full advantage of on-board filtering and noise attenuation, in addition to excellent on-chip power-supply rejection, this part provides a separate power-supply pin, V_{CCA} , for the VCO circuitry. [Figure 3](#) illustrates the recommended power-supply filter network for V_{CCA} . The purpose of this design technique is to ensure clean input power supply to the VCO circuitry and to improve the overall immunity to power-supply noise. This network requires that the power supply is $+3.3V \pm 5\%$. Decoupling capacitors should be used on all other supply pins for best performance. All supply connections should be driven from the same source.

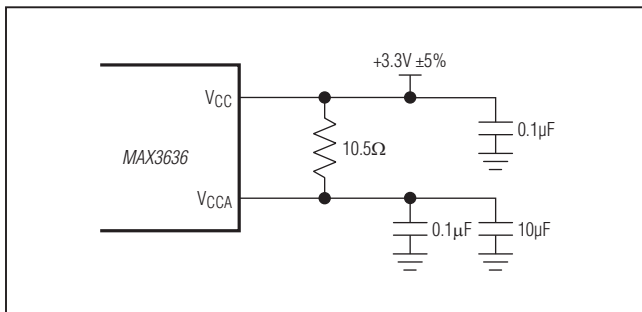

Figure 3. Power-Supply Filter

Ground Connection

The 48-pin TQFN package features an exposed pad (EP), which provides a low resistance thermal path for heat removal from the IC and also the electrical ground. For proper operation, the EP must be connected to the circuit board ground plane with multiple vias.

Crystal Selection and Layout

The IC features an integrated on-chip crystal oscillator to minimize system implementation cost. The crystal oscillator is designed to drive a fundamental mode, AT-cut crystal resonator. See [Table 12](#) for recommended crystal specifications. See [Figure 4](#) for the crystal equivalent circuit and [Figure 5](#) for the recommended external capacitor connections. The crystal, trace, and two external capacitors should be placed on the board as close as possible to the XIN and XOUT pins to reduce crosstalk of active signals into the oscillator.

The total load capacitance for the crystal is a combination of external and on-chip capacitance. The layout shown in [Figure 6](#) gives approximately 1.7pF of trace plus footprint capacitance per side of the crystal. Note the ground plane is removed under the crystal to minimize capacitance. There is approximately 2.5pF of on-chip capacitance between XIN and XOUT. With an external 27pF capacitor connected to XIN and a 33pF capacitor connected to XOUT, the total load capacitance for the crystal is approximately 18pF. The XIN and XOUT pins can be left open if not used.

Table 12. Crystal Selection Parameters

PARAMETER	SYMBOL	MIN	TYP	MAX	UNITS
Crystal Oscillation Frequency	f_{OSC}	18	25	33.5	MHz
Shunt Capacitance	C_0		2.0	7.0	pF
Load Capacitance	C_L		18		pF
Equivalent Series Resistance (ESR)	R_S		10	50	Ω
Maximum Crystal Drive Level				200	μW

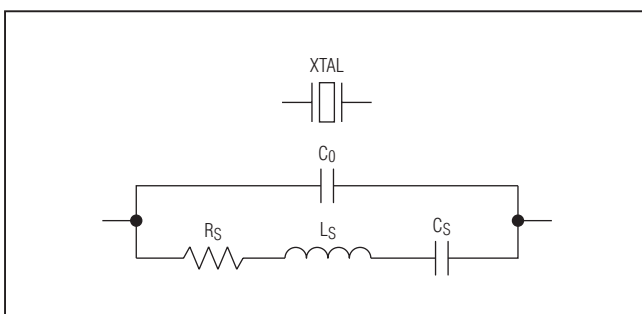

Figure 4. Crystal Equivalent Circuit

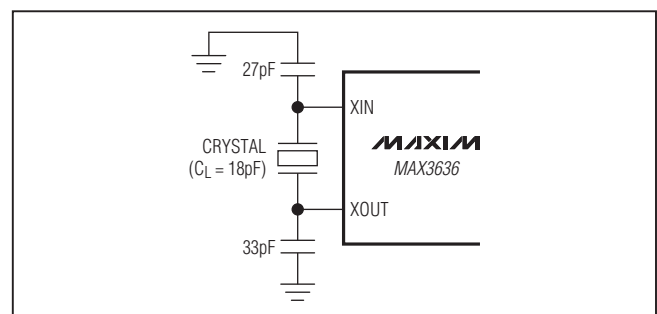

Figure 5. Crystal, Capacitor Connections

Low-Jitter, Wide Frequency Range, Programmable Clock Generator with 10 Outputs

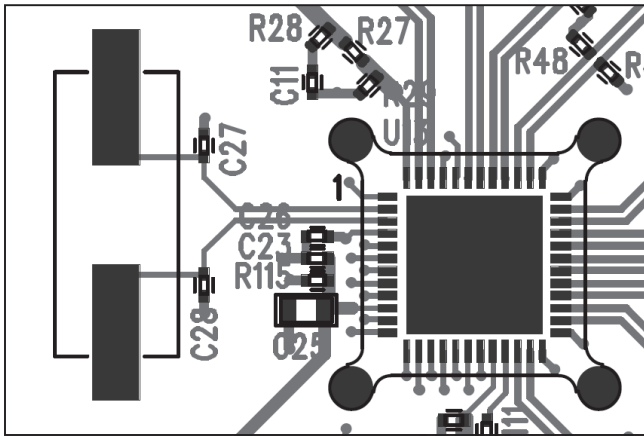

Figure 6. Crystal Layout

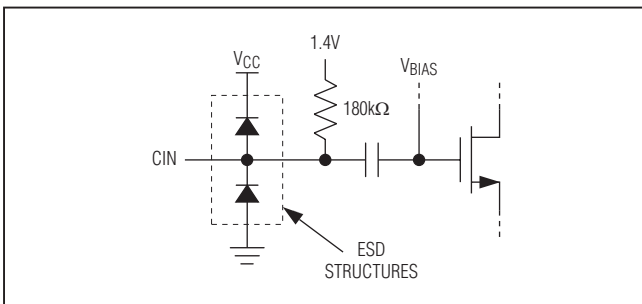

Figure 7. Equivalent CIN Circuit

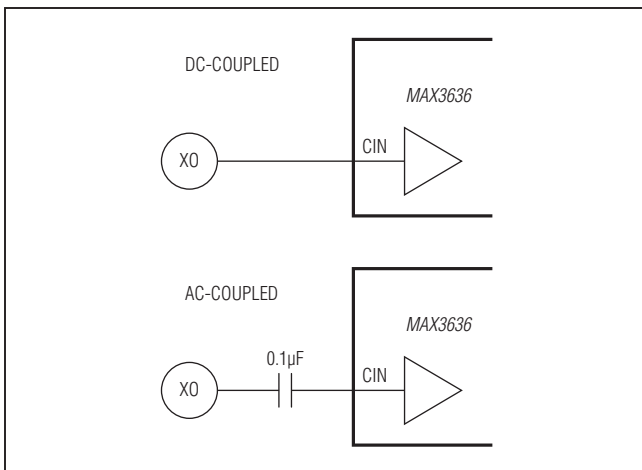

Figure 8. Interface to CIN

Interfacing with LVCMOS Input

The equivalent LVCMOS input circuit for CIN is given in [Figure 7](#). This input is internally biased to allow AC- or DC-coupling, and has 180kΩ input impedance. See [Figure 8](#) for the interface circuit. No signal should be applied to CIN if not used.

Interfacing with Differential Input

The equivalent input circuit for DIN is given in [Figure 9](#). This input operates up to 350MHz and contains an internal 100Ω differential termination as well as a 35Ω common-mode termination. The common-mode termination ensures good signal integrity when connected to a source with large common-mode signals. The input can accept DC-coupled LVPECL signals, and is internally biased to accept AC-coupled LVDS, CML, and LVPECL signals ([Figure 10](#)). No signal should be applied to DIN if not used.

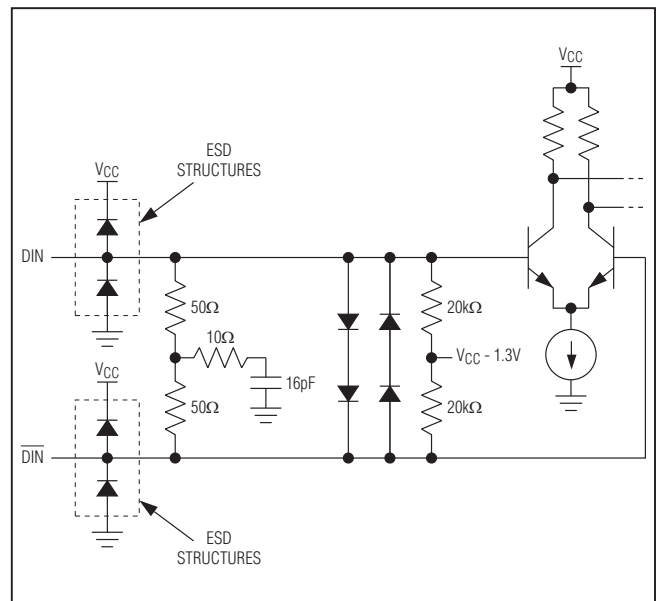

Figure 9. Equivalent DIN Circuit

Low-Jitter, Wide Frequency Range, Programmable Clock Generator with 10 Outputs

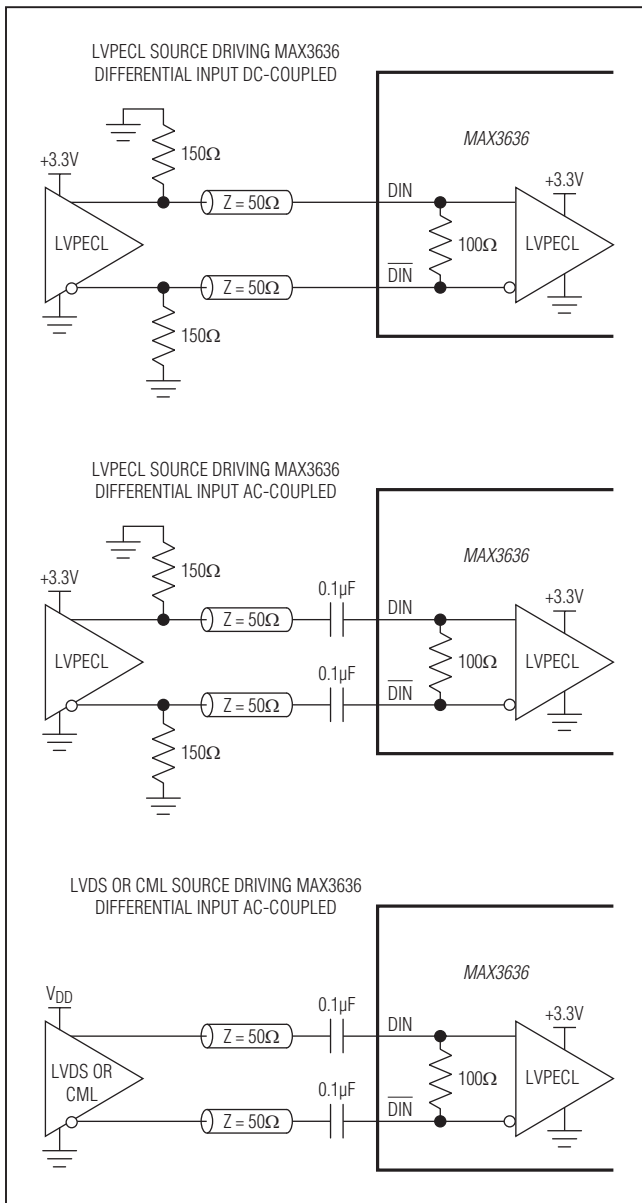

Figure 10. Interfacing to DIN

Interfacing with LVPECL Outputs

The equivalent LVPECL output circuit is given in [Figure 11](#). These outputs are designed to drive a pair of 50Ω transmission lines terminated with 50Ω to $V_{TT} = V_{CC} - 2V$. If a separate termination voltage (V_{TT}) is not available, other terminations methods can be used, as shown in [Figure 12](#). For more information on LVPECL terminations and how to interface with other logic families, refer to [Application Note 291: HFAN-01.0: Introduction to LVDS, PECL, and CML](#).

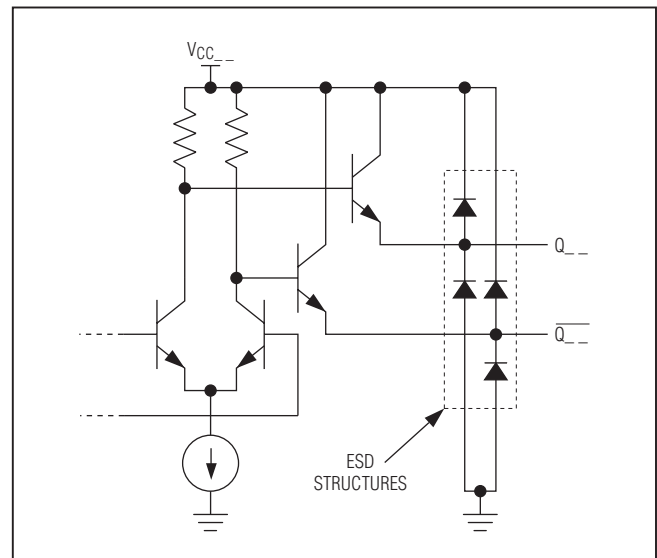

Figure 11. Equivalent LVPECL Output Circuit

Low-Jitter, Wide Frequency Range, Programmable Clock Generator with 10 Outputs

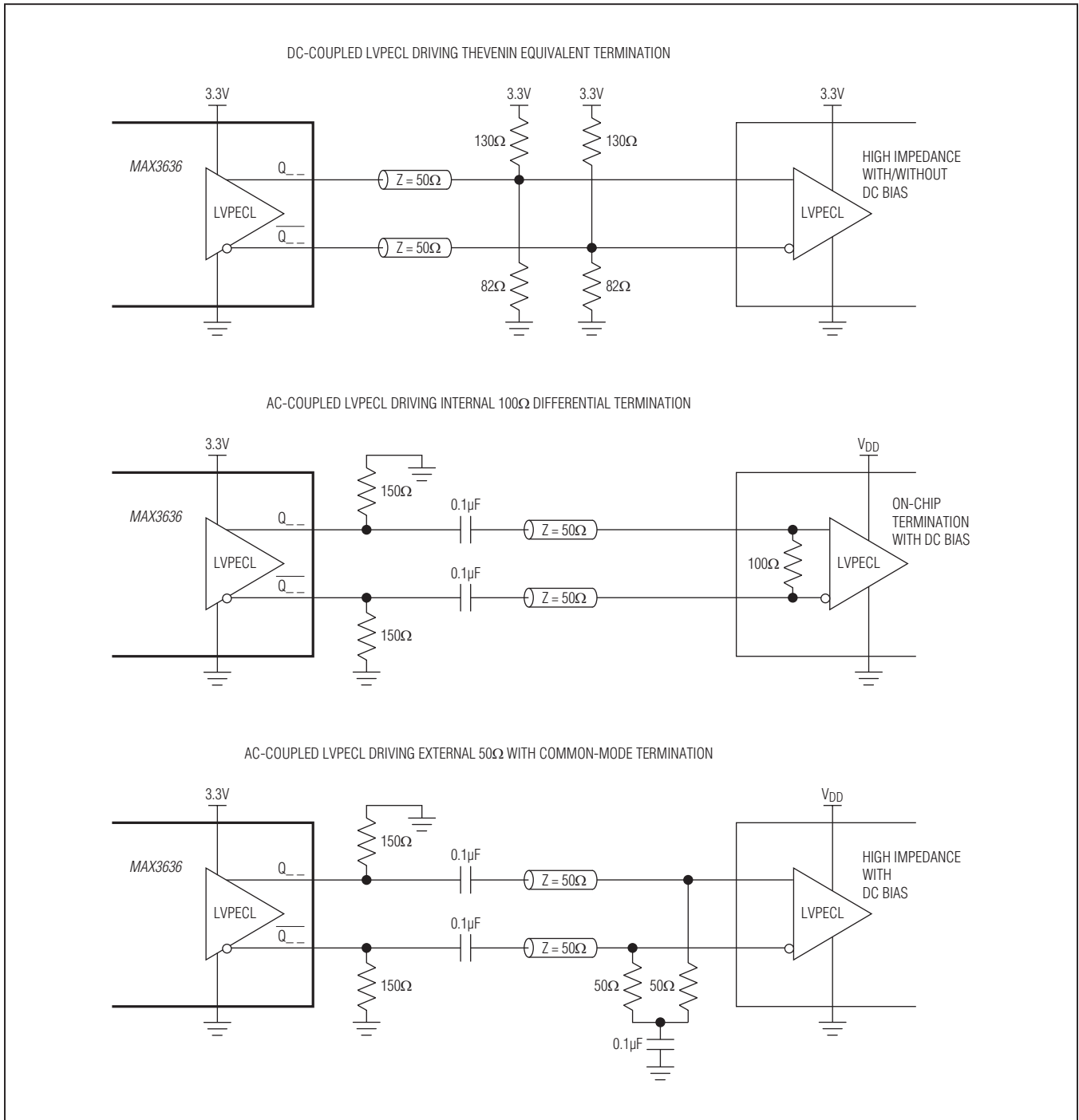

Figure 12. Interface to LVPECL Outputs

Low-Jitter, Wide Frequency Range, Programmable Clock Generator with 10 Outputs

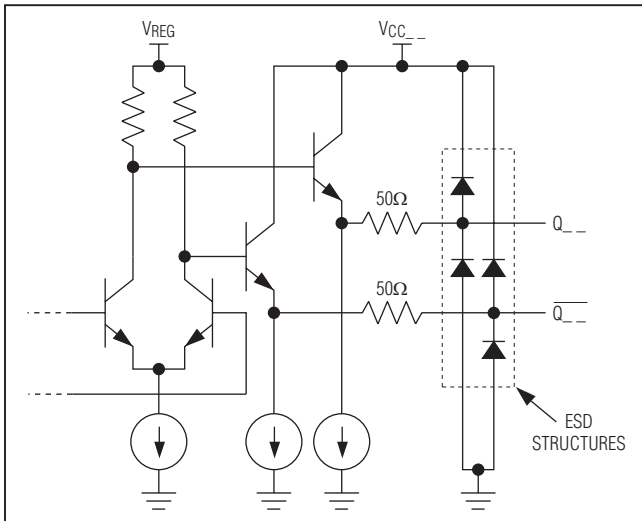

Figure 13. Equivalent LVDS Output Circuit

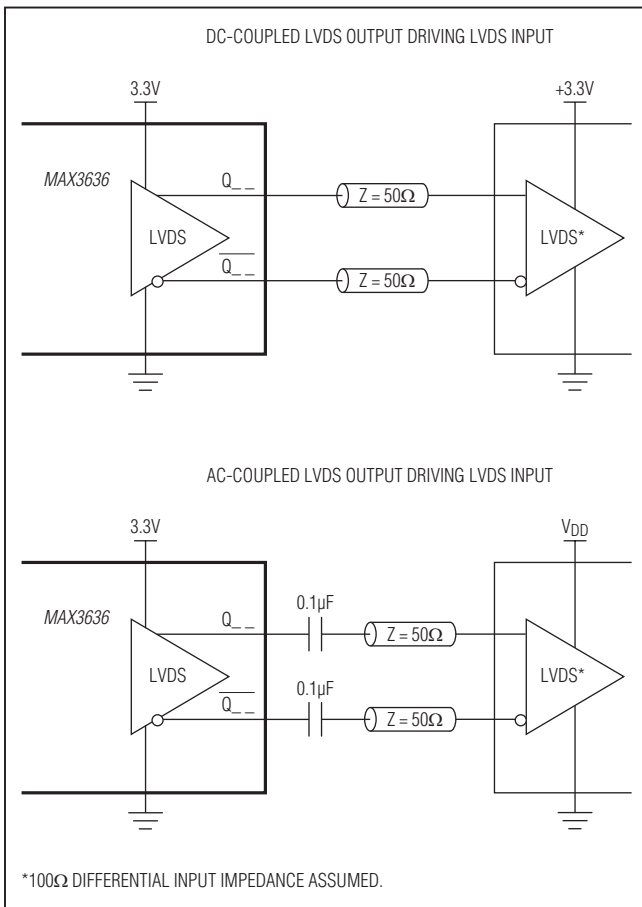

Figure 14. Interface to LVDS Outputs

Interfacing with LVDS Outputs

The equivalent LVDS output circuit is given in [Figure 13](#). These outputs provide 100Ω differential output impedance designed to drive a 100Ω differential transmission line terminated with a 100Ω differential load. Example interface circuits are shown in [Figure 14](#). For more information on LVDS terminations and how to interface with other logic families, refer to [Application Note 291: HFAN-01.0: Introduction to LVDS, PECL, and CML](#).

Interfacing with LVCMOS Output

The equivalent LVCMOS output circuit is given in [Figure 15](#). This output provides 15Ω output impedance and is designed to drive a high-impedance load. A series resistor of 33Ω is recommended at the LVCMOS output before the transmission line. An example interface circuit is shown in [Figure 16](#).

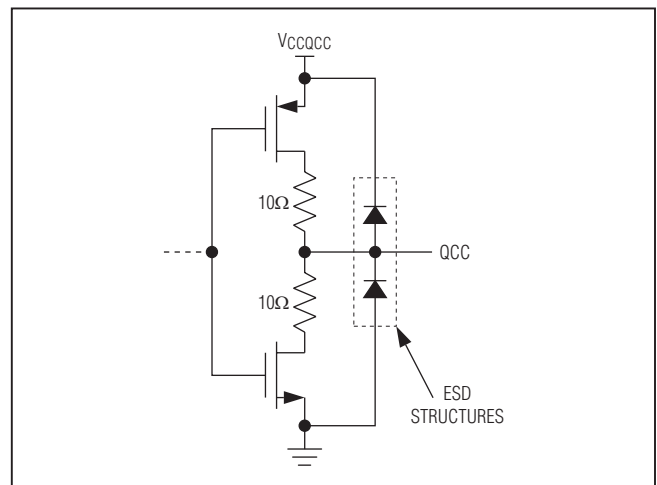

Figure 15. Equivalent LVCMOS Output Circuit

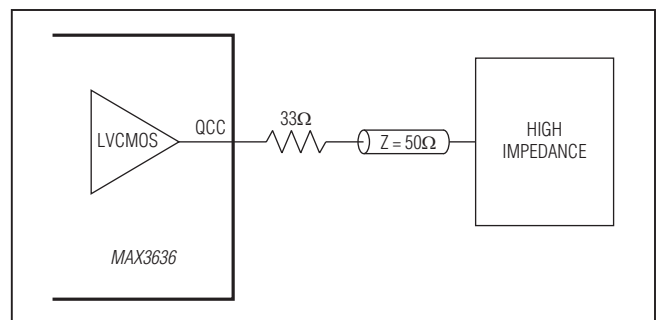

Figure 16. Interface to LVCMOS Output

Low-Jitter, Wide Frequency Range, Programmable Clock Generator with 10 Outputs

Layout Considerations

The inputs and outputs are the most critical paths for the MAX3636; great care should be taken to minimize discontinuities on the transmission lines. Here are some suggestions for maximizing the performance of the IC:

- An uninterrupted ground plane should be positioned beneath the clock outputs. The ground plane under the crystal should be removed to minimize capacitance.
- Supply decoupling capacitors should be placed close to the supply pins, preferably on the same side of the board as the IC.
- Take care to isolate input traces from the IC outputs.

- The crystal, trace, and two external capacitors should be placed on the board as close as possible to the XIN and XOUT pins to reduce crosstalk of active signals into the oscillator.
- Maintain 100Ω differential (or 50Ω single-ended) transmission line impedance into and out of the part.
- Provide space between differential output pairs to reduce crosstalk, especially if the outputs are operating at different frequencies.
- Use multilayer boards with an uninterrupted ground plane to minimize EMI and crosstalk.

Refer to the MAX3636 Evaluation Kit for more information.

Typical Application Circuits

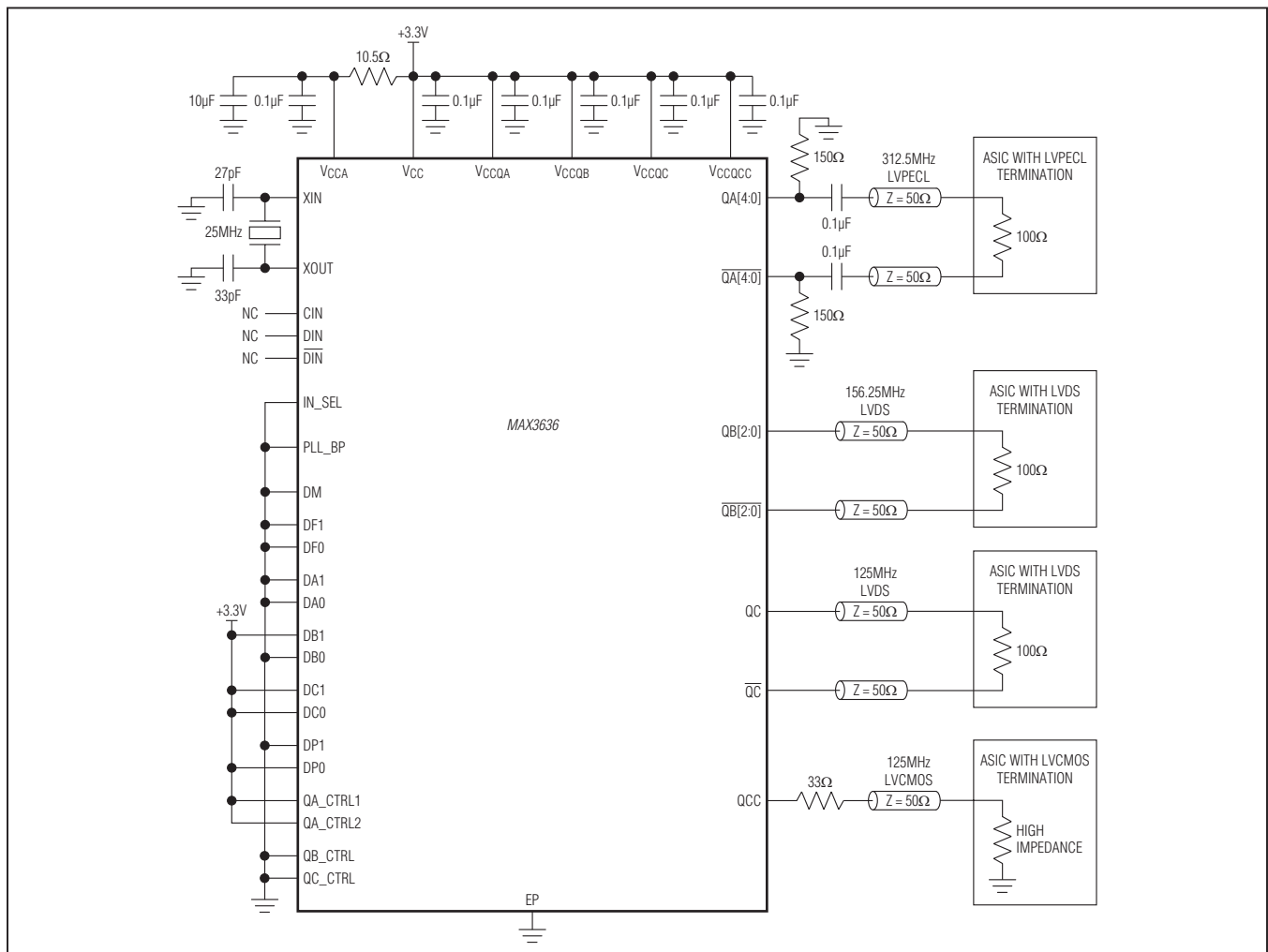

Low-Jitter, Wide Frequency Range, Programmable Clock Generator with 10 Outputs

Typical Application Circuits (continued)

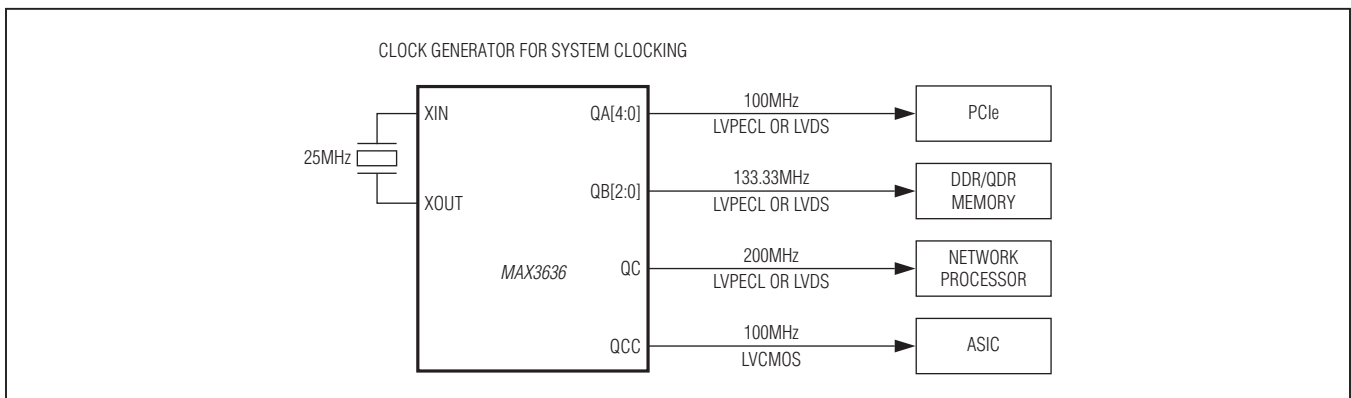
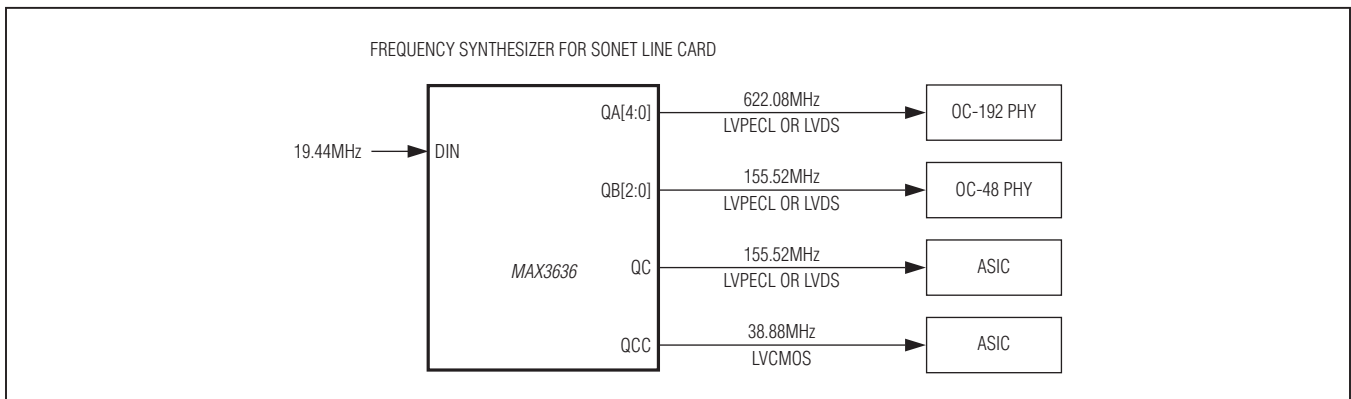
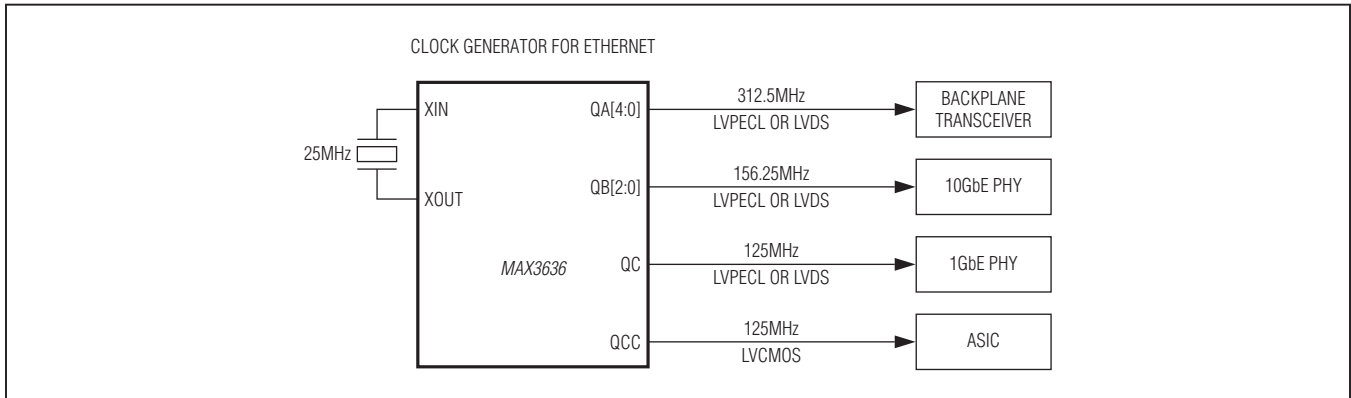

MAX3636

Low-Jitter, Wide Frequency Range, Programmable Clock Generator with 10 Outputs

Typical Application Circuits (continued)

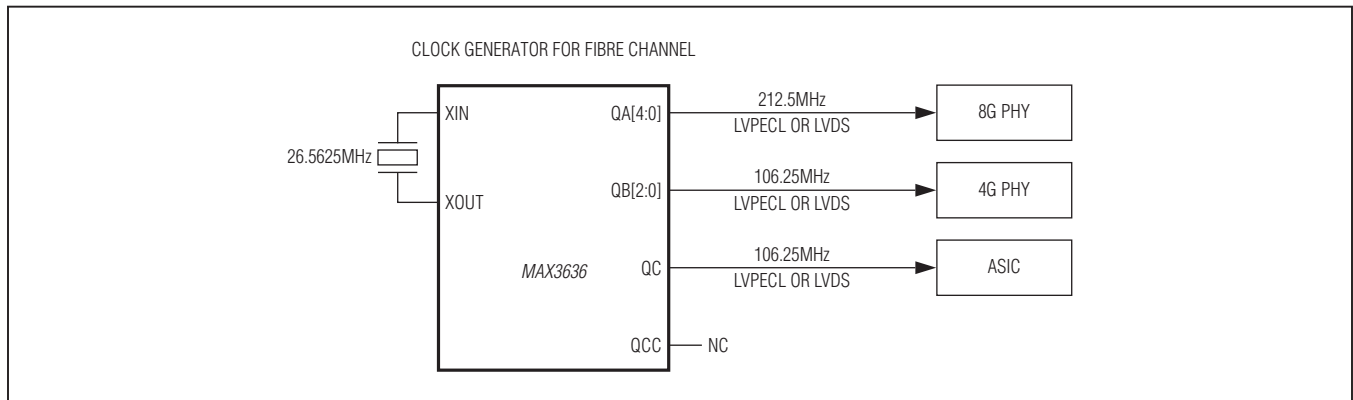

Ordering Information

PART	TEMP RANGE	PIN-PACKAGE
MAX3636ETM+	-40°C to +85°C	48 TQFN-EP*

+ Denotes a lead(Pb)-free/RoHS-compliant package.

*EP = Exposed pad.

Chip Information

PROCESS: BiCMOS

Package Information

For the latest package outline information and land patterns (footprints), go to <http://www.microsemi.com>. Note that a "+", "#", or "-" in the package code indicates RoHS status only. Package drawings may show a different suffix character, but the drawing pertains to the package regardless of RoHS status.

PACKAGE TYPE	PACKAGE CODE	OUTLINE NO.	LAND PATTERN NO.
48 TQFN-EP	T4877+4	21-0144	90-0130

MAX3636

Low-Jitter, Wide Frequency Range, Programmable Clock Generator with 10 Outputs

Revision History

REVISION NUMBER	REVISION DATE	DESCRIPTION	PAGES CHANGED
0	9/11	Initial release	—



Microsemi Corporate Headquarters
One Enterprise, Aliso Viejo CA 92656 USA
Within the USA: +1 (949) 380-6100
Sales: +1 (949) 380-6136
Fax: +1 (949) 215-4996

Microsemi Corporation (NASDAQ: MSCC) offers a comprehensive portfolio of semiconductor solutions for: aerospace, defense and security; enterprise and communications; and industrial and alternative energy markets. Products include high-performance, high-reliability analog and RF devices, mixed signal and RF integrated circuits, customizable SoCs, FPGAs, and complete subsystems. Microsemi is headquartered in Aliso Viejo, Calif. Learn more at www.microsemi.com.

© 2012 Microsemi Corporation. All rights reserved. Microsemi and the Microsemi logo are trademarks of Microsemi Corporation. All other trademarks and service marks are the property of their respective owners.



Компания «ЭлектроПласт» предлагает заключение долгосрочных отношений при поставках импортных электронных компонентов на взаимовыгодных условиях!

Наши преимущества:

- Оперативные поставки широкого спектра электронных компонентов отечественного и импортного производства напрямую от производителей и с крупнейших мировых складов;
- Поставка более 17-ти миллионов наименований электронных компонентов;
- Поставка сложных, дефицитных, либо снятых с производства позиций;
- Оперативные сроки поставки под заказ (от 5 рабочих дней);
- Экспресс доставка в любую точку России;
- Техническая поддержка проекта, помощь в подборе аналогов, поставка прототипов;
- Система менеджмента качества сертифицирована по Международному стандарту ISO 9001;
- Лицензия ФСБ на осуществление работ с использованием сведений, составляющих государственную тайну;
- Поставка специализированных компонентов (Xilinx, Altera, Analog Devices, Intersil, Interpoint, Microsemi, Aeroflex, Peregrine, Syfer, Eurofarad, Texas Instrument, Miteq, Cobham, E2V, MA-COM, Hittite, Mini-Circuits, General Dynamics и др.);

Помимо этого, одним из направлений компании «ЭлектроПласт» является направление «Источники питания». Мы предлагаем Вам помощь Конструкторского отдела:

- Подбор оптимального решения, техническое обоснование при выборе компонента;
- Подбор аналогов;
- Консультации по применению компонента;
- Поставка образцов и прототипов;
- Техническая поддержка проекта;
- Защита от снятия компонента с производства.



Как с нами связаться

Телефон: 8 (812) 309 58 32 (многоканальный)

Факс: 8 (812) 320-02-42

Электронная почта: org@eplast1.ru

Адрес: 198099, г. Санкт-Петербург, ул. Калинина, дом 2, корпус 4, литера А.