

SL1003A Series

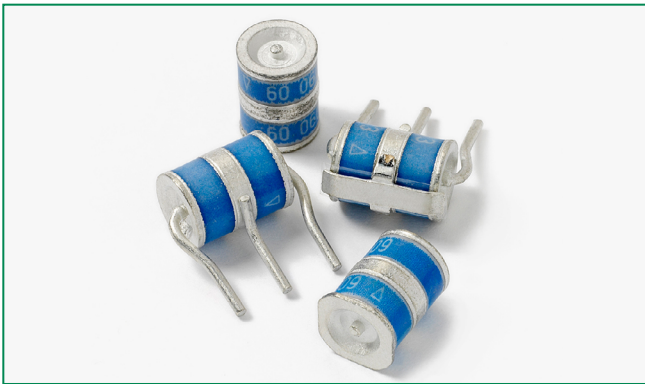

Description

The SL1003A series has been especially developed for Broadband equipment. Special design features provide high levels of protection against fast rising transients in the 100V/μs to 1kV/μs range usually caused by lightning disturbances.

These devices have ultra low capacitance 1.5pF and present insignificant signal losses up to 1.5GHz. These devices are extremely robust and are able to divert a 5000A pulse without destruction. For AC Power Cross of long duration, over-current protection is recommended.

Agency Approvals

AGENCY	AGENCY FILE NUMBER
	E128662

3 Electrode GDT Graphical Symbol



Features

- RoHS compliant
- Low insertion loss
- Surface mountable
- 5kA surge capability tested with 8/20/μs pulse as defined by IEC 61000-4-5
- GHz working frequency
- Excellent response to fast rising transients
- Can be used to meet Telcordia GR1089 without series resistance
- 10/700 6kV capability, as per ITU-Tk.21, enhanced test level
- 2000 Amp 2/10μs surge rating

Applications

- Broadband equipment
- ADSL equipment
- XDSL equipment
- Satellite and CATV equipment
- General telecom equipment

Electrical Characteristics

Part Number	Device Specifications (at 25°C)							Life Ratings						
	DC Breakdown in Volts ^{1,2,3} (@100V/s)			Impulse Breakdown in Volts ^{2,3} (@100V/μs)	Impulse Breakdown In Volts ^{2,3} (@1kV/μs)	Insulation Resistance	Capacitance (@1MHz 0V Bias)	Arc Voltage (on state Voltage) @1Amp Min	Surge Life (@200A 10/1000μs)	Nominal Impulse Discharge Current (@20μs)	Nominal AC Discharge Current (10x1s @50Hz)	AC Discharge Current (9 Cycles @ 50Hz)	DC Holdover Voltage ⁴	Max Impulse Discharge Current (1 Application)
	MIN	TYP	MAX	MAX		MIN	MAX	TYP					TYP	@ 10/350μs
SL1003A090	72	90	108	600	700	10 ⁹ Ω (at 50V)	1.5 pF	~10 to 35 V	300 shots	10 shots (@10kA)	10 A	30 A	50 V	2 kA
SL1003A230	184	230	276											
SL1003A250	200	250	300											
SL1003A260	210	260	310											
SL1003A300	240	300	360		750	850							10 ⁹ Ω (at 100V)	
SL1003A350	280	350	420		800	900								
SL1003A400	320	400	480		850	950								
SL1003A450	360	450	540		900	1000								
SL1003A500	400	500	600	1100	1400									

Notes:

- At delivery AQL 0.65 level II, DIN ISO 2859
- In ionized mode, tested according to ITU-T Rec. K.12
- Comparable to the silicon measurement Switching Voltage (Vs)
- Reference REA PE-80, 0.2A. Tested to ITU-T Rec. K.12 and REA PE-80 < 150 msec.

Product Characteristics

Materials	Leaded Device: Tin-plated copper wire Core and Surface Mount: Dull Tin-plated
Product Marking	Littelfuse 'LF' Mark, voltage and date code

Glow to Arc Transition Current	~1 Amp
Glow Voltage	~60 to 200 Volts
Storage and Operational Temperature	-40 to +90°C

Device Dimensions

For SL1003A series:

Dimensions are in millimeters [and inches]

'R' Type Radial Lead Devices (SL1003AxxxR-001)

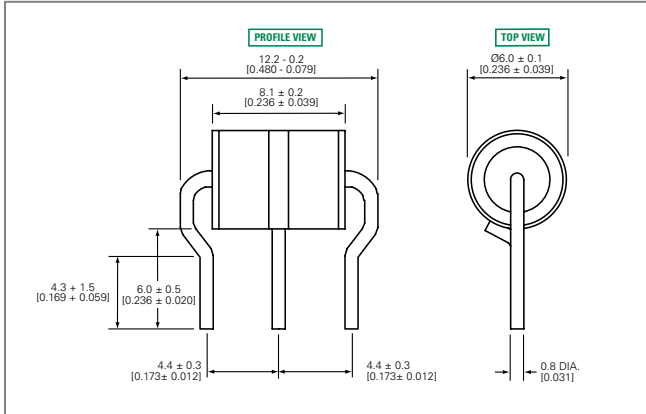

'C' Type Core Devices

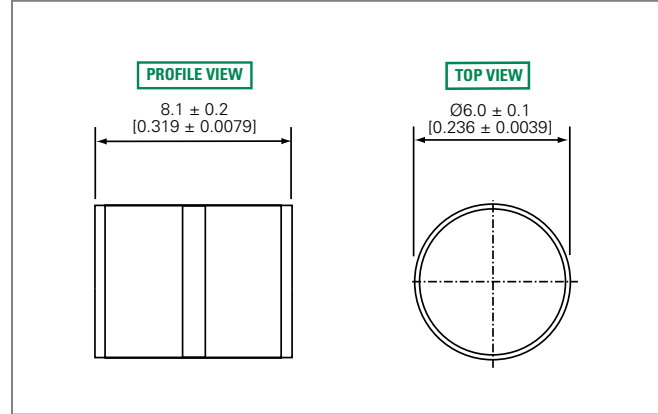

'R' Type Radial Lead Devices (SL1003AxxxR and SL1003AxxxRF)

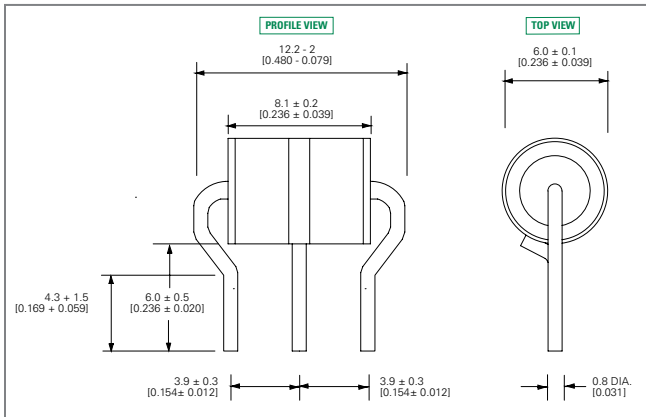

'SM' Type Surface Mount Devices

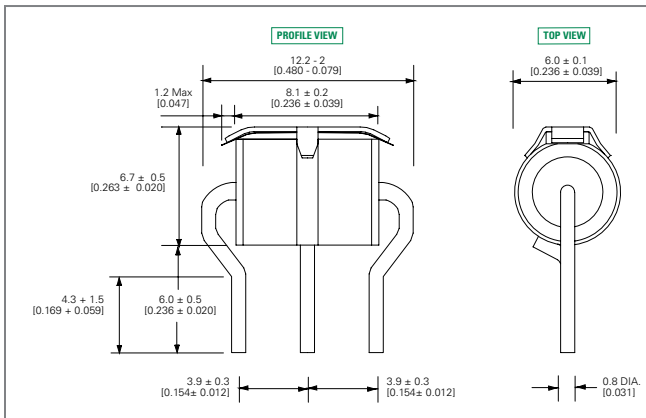
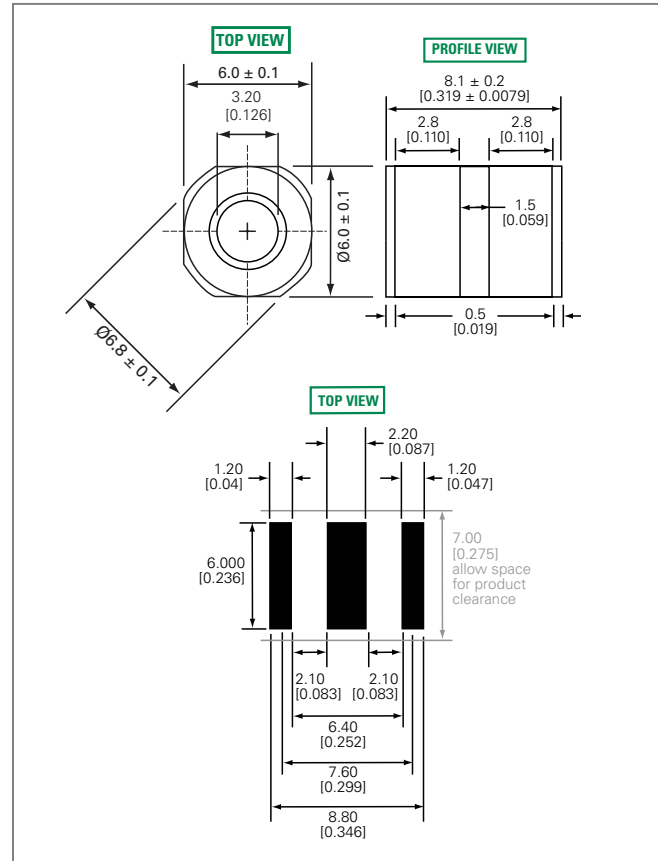

Soldering Parameters - Reflow Soldering (Surface Mount Devices)

Reflow Condition		Pb-free assembly
Pre Heat	- Temperature Min ($T_{s(min)}$)	150°C
	- Temperature Max ($T_{s(max)}$)	200°C
	- Time (Min to Max) (t_s)	60 – 180 seconds
Average Ramp-up Rate (Liquidus Temp (T_L) to peak)		3°C/second max.
$T_{s(max)}$ to T_L - Ramp-up Rate		5°C/second max.
Reflow	- Temperature (T_L) (Liquidus)	217°C
	- Temperature (t_L)	60 – 150 seconds
Peak Temperature (T_p)		260 ^{+0/-5} °C
Time within 5°C of Actual Peak Temperature (t_p)		10 – 30 seconds
Ramp-down Rate		6°C/second max.
Time 25°C to Peak Temperature (T_p)		8 minutes max.
Do not exceed		260°C

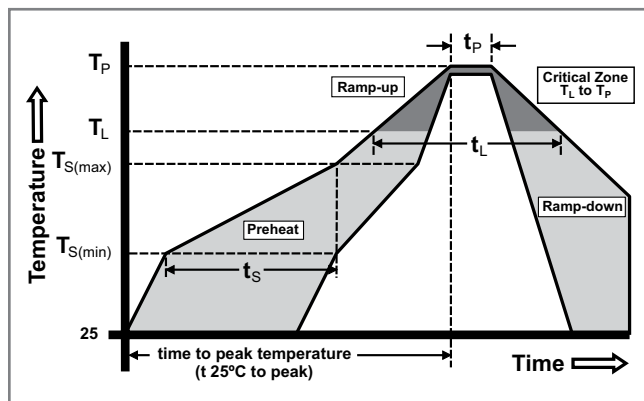

Soldering Parameters - Wave Soldering (Thru-Hole Devices)

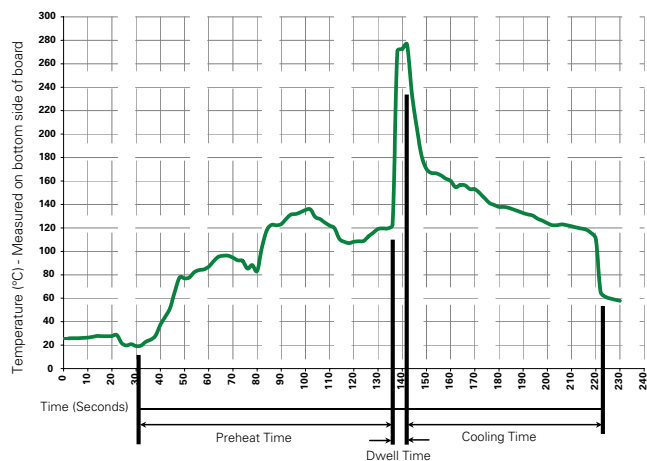

Recommended Process Parameters:

Wave Parameter	Lead-Free Recommendation
Preheat:	
(Depends on Flux Activation Temperature)	(Typical Industry Recommendation)
Temperature Minimum:	100° C
Temperature Maximum:	150° C
Preheat Time:	60-180 seconds
Solder Pot Temperature:	280° C Maximum
Solder Dwell Time:	2-5 seconds

Soldering Parameters - Hand Soldering

Solder Iron Temperature: 350° C +/- 5°C
 Heating Time: 5 seconds max.

Packaging

'C' Type Core Items: Package bulk pack in polybag, 500 pcs/bag

'R' and 'RF' Type Radial Lead Items: Packed in tray, 100 pcs/tray

'SM' Type Surface Mount Items: Packaged tape and reel carrier, 700 pcs/reel (specifications below)

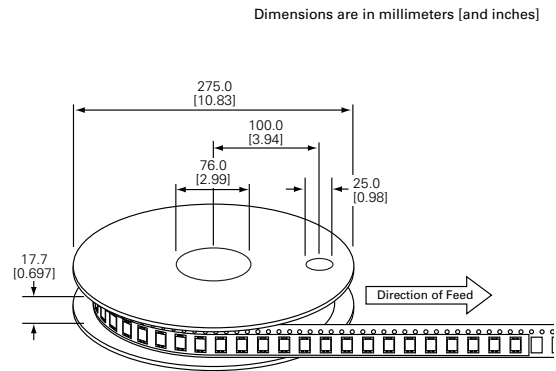
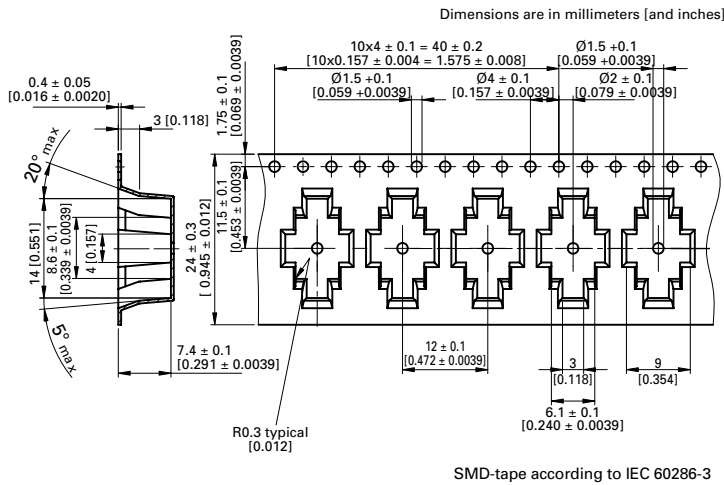

Part Numbering System and Ordering Information

SL1003 A XXX XX

Type 3 Pole Arrestor

Voltage

Pin Configuration

- C** = Core type (Packed in polybag, 500pcs/bag)
- R** = Radial Lead without Failsafe (Packed in tray, 100pcs/tray)
- RF** = Radial Lead with Failsafe (Packed in tray, 100pcs/tray)
- SM** = Surface Mount (Packed in carrier and tape, 700pcs/reel)



Компания «ЭлектроПласт» предлагает заключение долгосрочных отношений при поставках импортных электронных компонентов на взаимовыгодных условиях!

Наши преимущества:

- Оперативные поставки широкого спектра электронных компонентов отечественного и импортного производства напрямую от производителей и с крупнейших мировых складов;
- Поставка более 17-ти миллионов наименований электронных компонентов;
- Поставка сложных, дефицитных, либо снятых с производства позиций;
- Оперативные сроки поставки под заказ (от 5 рабочих дней);
- Экспресс доставка в любую точку России;
- Техническая поддержка проекта, помощь в подборе аналогов, поставка прототипов;
- Система менеджмента качества сертифицирована по Международному стандарту ISO 9001;
- Лицензия ФСБ на осуществление работ с использованием сведений, составляющих государственную тайну;
- Поставка специализированных компонентов (Xilinx, Altera, Analog Devices, Intersil, Interpoint, Microsemi, Aeroflex, Peregrine, Syfer, Eurofarad, Texas Instrument, Miteq, Cobham, E2V, MA-COM, Hittite, Mini-Circuits, General Dynamics и др.);

Помимо этого, одним из направлений компании «ЭлектроПласт» является направление «Источники питания». Мы предлагаем Вам помощь Конструкторского отдела:

- Подбор оптимального решения, техническое обоснование при выборе компонента;
- Подбор аналогов;
- Консультации по применению компонента;
- Поставка образцов и прототипов;
- Техническая поддержка проекта;
- Защита от снятия компонента с производства.



Как с нами связаться

Телефон: 8 (812) 309 58 32 (многоканальный)

Факс: 8 (812) 320-02-42

Электронная почта: org@eplast1.ru

Адрес: 198099, г. Санкт-Петербург, ул. Калинина, дом 2, корпус 4, литера А.