

## Dual 1.5 Gbps 2:1/1:2 LVDS Mux/Buffer with Pre-Emphasis and IEEE 1149.6

 Check for Samples: [SCAN15MB200](#)

### FEATURES

- 1.5 Gbps Data Rate Per Channel
- Configurable Off/On Pre-emphasis Drives Lossy Backplanes and Cables
- LVDS/BLVDS/CML/LVPECL Compatible Inputs, LVDS Compatible Outputs
- Low Output Skew and Jitter
- On-chip 100Ω Input and Output Termination
- IEEE 1149.1 and 1149.6 Compliant
- 15 kV ESD Protection on LVDS Inputs/Outputs
- Hot Plug Protection
- Single 3.3V Supply
- Industrial -40 to +85°C Temperature Range
- 48-Pin WQFN Package

### DESCRIPTION

The SCAN15MB200 is a dual-port 2 to 1 multiplexer and 1 to 2 repeater/buffer. High-speed data paths and flow-through pinout minimize internal device jitter and simplify board layout, while pre-emphasis overcomes ISI jitter effects from lossy backplanes and cables. The differential inputs and outputs interface to LVDS or Bus LVDS signals such as those on National's 10-, 16-, and 18-bit Bus LVDS SerDes, or to CML or LVPECL signals.

Integrated IEEE 1149.1 (JTAG) and 1149.6 circuitry supports testability of both single-ended LVTTTL/CMOS and high-speed differential PCB interconnects. The 3.3V supply, CMOS process, and robust I/O ensure high performance at low power over the entire industrial -40 to +85°C temperature range.

### Typical Application

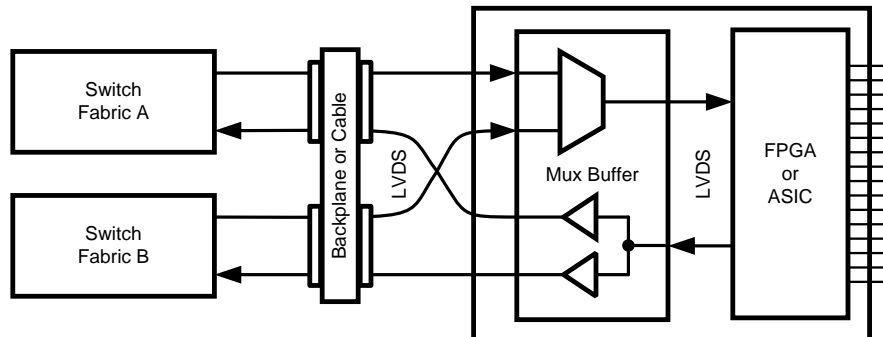

Please be aware that an important notice concerning availability, standard warranty, and use in critical applications of Texas Instruments semiconductor products and disclaimers thereto appears at the end of this data sheet.

All trademarks are the property of their respective owners.

**Block Diagram**

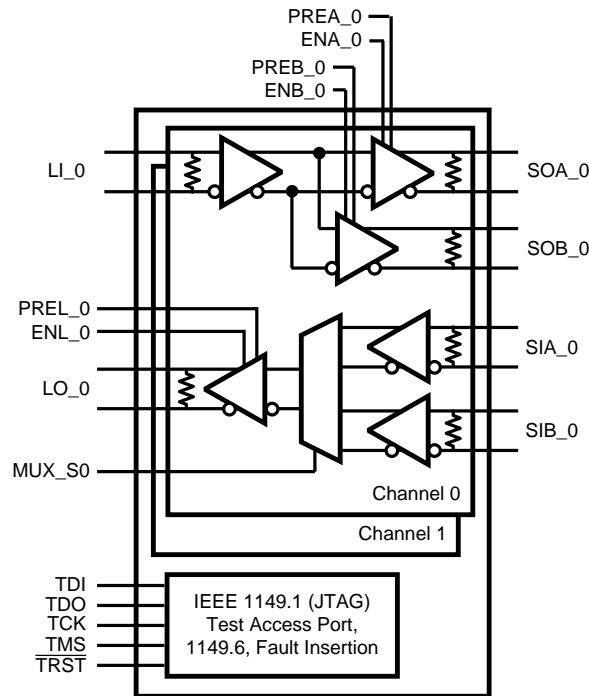

**Figure 1. SCAN15MB200 Block Diagram**

**Pin Descriptions**

| Pin Name                                | WQFN Pin Number | I/O, Type | Description   |
|---|-----------------|-----------|---|
| <b>SWITCH SIDE DIFFERENTIAL INPUTS</b>  |                 |           |   |
| SIA_0+<br>SIA_0-                        | 30<br>29        | I, LVDS   | Switch A-side Channel 0 inverting and non-inverting differential inputs. LVDS, Bus LVDS, CML, or LVPECL compatible.       |
| SIA_1+<br>SIA_1-                        | 19<br>20        | I, LVDS   | Switch A-side Channel 1 inverting and non-inverting differential inputs. LVDS, Bus LVDS, CML, or LVPECL compatible.       |
| SIB_0+<br>SIB_0-                        | 28<br>27        | I, LVDS   | Switch B-side Channel 0 inverting and non-inverting differential inputs. LVDS, Bus LVDS, CML, or LVPECL compatible.       |
| SIB_1+<br>SIB_1-                        | 21<br>22        | I, LVDS   | Switch B-side Channel 1 inverting and non-inverting differential inputs. LVDS, Bus LVDS, CML, or LVPECL compatible.       |
| <b>LINE SIDE DIFFERENTIAL INPUTS</b>    |                 |           |   |
| LI_0+<br>LI_0-                          | 40<br>39        | I, LVDS   | Line-side Channel 0 inverting and non-inverting differential inputs. LVDS, Bus LVDS, CML, or LVPECL compatible.           |
| LI_1+<br>LI_1-                          | 9<br>10         | I, LVDS   | Line-side Channel 1 inverting and non-inverting differential inputs. LVDS, Bus LVDS, CML, or LVPECL compatible.           |
| <b>SWITCH SIDE DIFFERENTIAL OUTPUTS</b> |                 |           |   |
| SOA_0+<br>SOA_0-                        | 34<br>33        | O, LVDS   | Switch A-side Channel 0 inverting and non-inverting differential outputs. LVDS compatible <sup>(1)</sup> <sup>(2)</sup> . |
| SOA_1+<br>SOA_1-                        | 15<br>16        | O, LVDS   | Switch A-side Channel 1 inverting and non-inverting differential outputs. LVDS compatible <sup>(1)</sup> <sup>(2)</sup> . |
| SOB_0+<br>SOB_0-                        | 32<br>31        | O, LVDS   | Switch B-side Channel 0 inverting and non-inverting differential outputs. LVDS compatible <sup>(1)</sup> <sup>(2)</sup> . |
| SOB_1+<br>SOB_1-                        | 17<br>18        | O, LVDS   | Switch B-side Channel 1 inverting and non-inverting differential outputs. LVDS compatible <sup>(1)</sup> <sup>(2)</sup> . |

(1) For interfacing LVDS outputs to CML or LVPECL compatible inputs, refer to the [applications](#) section of this datasheet (planned).  
 (2) The LVDS outputs do not support a multidrop (BLVDS) environment. The LVDS output characteristics of the SCAN15MB200 device have been optimized for point-to-point backplane and cable applications.

**Pin Descriptions (continued)**

| Pin Name                              | WQFN Pin Number      | I/O, Type | Description  |
|---------------------------------------|----------------------|-----------|--|
| <b>LINE SIDE DIFFERENTIAL OUTPUTS</b> |                      |           |  |
| LO_0+<br>LO_0-                        | 42<br>41             | O, LVDS   | Line-side Channel 0 inverting and non-inverting differential outputs. LVDS compatible <sup>(3)</sup> <sup>(4)</sup> .  |
| LO_1+<br>LO_1-                        | 7<br>8               | O, LVDS   | Line-side Channel 1 inverting and non-inverting differential outputs. LVDS compatible <sup>(3)</sup> <sup>(4)</sup> .  |
| <b>DIGITAL CONTROL INTERFACE</b>      |                      |           |  |
| MUX_S0<br>MUX_S1                      | 38<br>11             | I, LVTTTL | Mux Select Control Inputs (per channel) to select which Switch-side input, A or B, is passed through to the Line-side.   |
| PREA_0<br>PREA_1<br>PREB_0<br>PREB_1  | 26<br>23<br>25<br>24 | I, LVTTTL | Output pre-emphasis control for Switch-side outputs. Each output driver on the Switch A-side and B-side has a separate pin to control the pre-emphasis on or off.  |
| PREL_0<br>PREL_1                      | 44<br>5              | I, LVTTTL | Output pre-emphasis control for Line-side outputs. Each output driver on the Line A-side and B-side has a separate pin to control the pre-emphasis on or off.  |
| ENA_0<br>ENA_1<br>ENB_0<br>ENB_1      | 36<br>13<br>35<br>14 | I, LVTTTL | Output Enable Control for Switch A-side and B-side outputs. Each output driver on the A-side and B-side has a separate enable pin.   |
| ENL_0<br>ENL_1                        | 45<br>4              | I, LVTTTL | Output Enable Control for The Line-side outputs. Each output driver on the Line-side has a separate enable pin.  |
| TDI                                   | 2                    | I, LVTTTL | Test Data Input to support IEEE 1149.1 features  |
| TDO                                   | 1                    | O, LVTTTL | Test Data Output to support IEEE 1149.1 features   |
| TMS                                   | 46                   | I, LVTTTL | Test Mode Select to support IEEE 1149.1 features   |
| TCK                                   | 47                   | I, LVTTTL | Test Clock to support IEEE 1149.1 features   |
| $\overline{\text{TRST}}$              | 3                    | I, LVTTTL | Test Reset to support IEEE 1149.1 features   |
| <b>POWER</b>                          |                      |           |  |
| V <sub>DD</sub>                       | 6, 12, 37,<br>43, 48 | I, Power  | V <sub>DD</sub> = 3.3V ±0.3V.  |
| GND                                   | See <sup>(5)</sup>   | I, Power  | Ground reference for LVDS and CMOS circuitry.<br>For the WQFN package, the DAP is used as the primary GND connection to the device. The DAP is the exposed metal contact at the bottom of the WQFN-48 package. It should be connected to the ground plane with at least 4 vias for optimal AC and thermal performance. |

(3) For interfacing LVDS outputs to CML or LVPECL compatible inputs, refer to the [applications](#) section of this datasheet (planned).

(4) The LVDS outputs do not support a multidrop (BLVDS) environment. The LVDS output characteristics of the SCAN15MB200 device have been optimized for point-to-point backplane and cable applications.

(5) Note that the DAP on the backside of the WQFN package is the primary GND connection for the device when using the WQFN package.

**Connection Diagram**

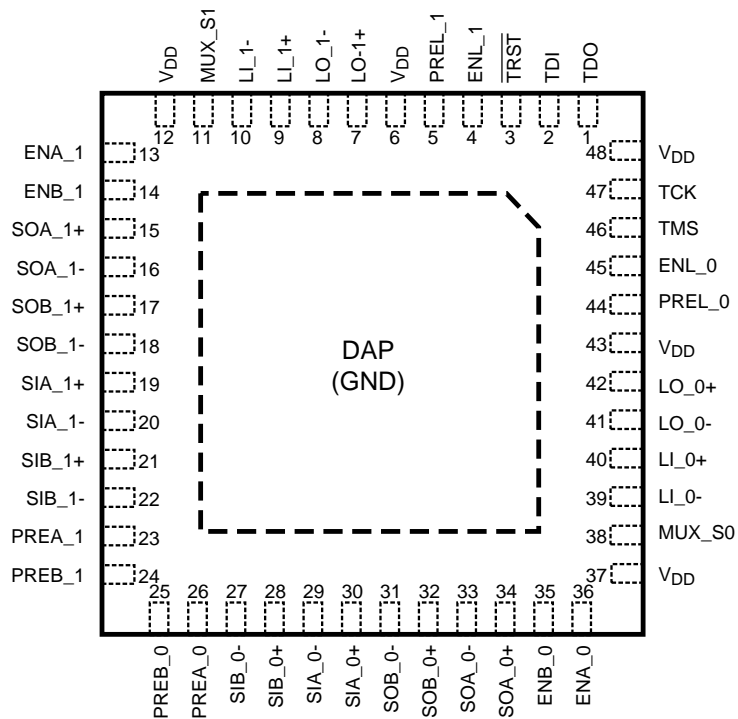

**WQFN Top View  
DAP = GND**

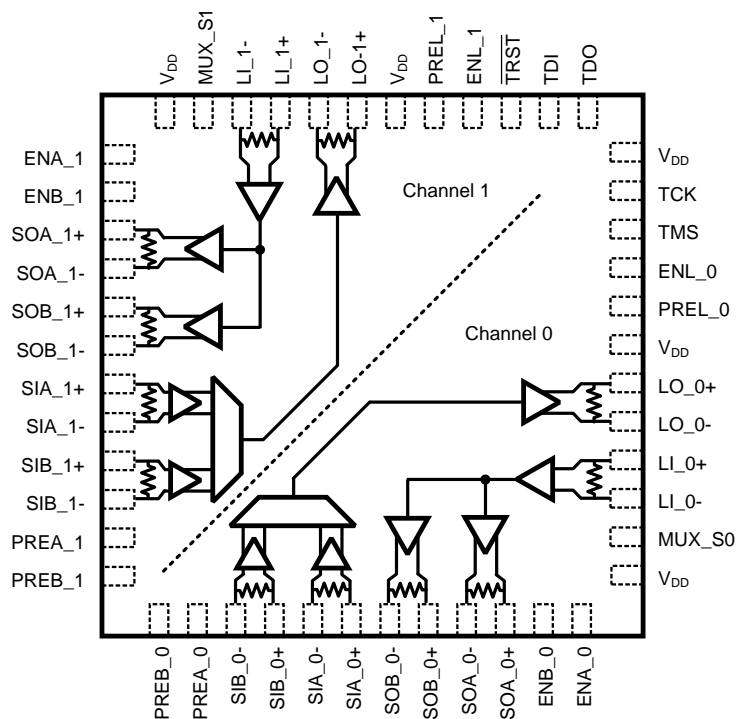

**Directional Signal Paths Top View  
(Refer to pin names for signal polarity)**

## OUTPUT CHARACTERISTICS

The output characteristics of the SCAN15MB200 have been optimized for point-to-point backplane and cable applications, and are not intended for multipoint or multidrop signaling.

A 100Ω output (source) termination resistor is incorporated in the device to eliminate the need for an external resistor, providing excellent drive characteristics by locating the source termination as close to the output as physically possible.

### Pre-Emphasis Controls

The pre-emphasis is used to compensate for long or lossy transmission media. Separate pins are provided for each output to minimize power consumption. Pre-emphasis is programmable to be off or on per the Pre-emphasis Control Table.

| PREx_n <sup>(1)</sup> | Output Pre-emphasis |
|-----------------------|---------------------|
| 0                     | 0%                  |
| 1                     | 100%                |

(1) Applies to PREA\_0, PREA\_1, PREB\_0, PREB\_1, PREL\_0, PREL\_1

### Multiplexer Truth Table <sup>(1)(2)</sup>

| Data Inputs |       | Control Inputs |                  | Output |
|-------------|-------|----------------|------------------|--------|
| SIA_0       | SIB_0 | MUX_S0         | ENL_0            | LO_0   |
| X           | valid | 0              | 1                | SIB_0  |
| valid       | X     | 1              | 1                | SIA_0  |
| X           | X     | X              | 0 <sup>(3)</sup> | Z      |

- (1) Same functionality for channel 1
- (2) X = Don't Care  
Z = High Impedance (TRI-STATE)
- (3) When all enable inputs from both channels are Low, the device enters a powerdown mode. Refer to the applications section titled [TRI-STATE and Powerdown Modes](#).

### Repeater/Buffer Truth Table <sup>(1)(2)</sup>

| Data Input | Control Inputs |       | Outputs          |                  |
|------------|----------------|-------|------------------|------------------|
| LI_0       | ENA_0          | ENB_0 | SOA_0            | SOB_0            |
| X          | 0              | 0     | Z <sup>(3)</sup> | Z <sup>(3)</sup> |
| valid      | 0              | 1     | Z                | LI_0             |
| valid      | 1              | 0     | LI_0             | Z                |
| valid      | 1              | 1     | LI_0             | LI_0             |

- (1) Same functionality for channel 1
- (2) X = Don't Care  
Z = High Impedance (TRI-STATE)
- (3) When all enable inputs from both channels are Low, the device enters a powerdown mode. Refer to the applications section titled [TRI-STATE and Powerdown Modes](#).



These devices have limited built-in ESD protection. The leads should be shorted together or the device placed in conductive foam during storage or handling to prevent electrostatic damage to the MOS gates.

## Absolute Maximum Ratings <sup>(1)</sup>

|  |                            | Value                     | Unit  |
|--|----------------------------|---------------------------|-------|
| Supply Voltage ( $V_{DD}$ )                |                            | -0.3V to +4.0             | V     |
| CMOS Input Voltage                         |                            | -0.3V to ( $V_{DD}+0.3$ ) | V     |
| LVDS Receiver Input Voltage <sup>(2)</sup> |                            | -0.3V to ( $V_{DD}+0.3$ ) | V     |
| LVDS Driver Output Voltage                 |                            | -0.3V to ( $V_{DD}+0.3$ ) | V     |
| LVDS Output Short Circuit Current          |                            | +40                       | mA    |
| Junction Temperature                       |                            | +150                      | °C    |
| Storage Temperature                        |                            | -65°C to +150             | °C    |
| Lead Temperature (Solder, 4sec)            |                            | 260                       | °C    |
| Max Pkg Power Capacity @ 25°C              |                            | 5.2                       | W     |
| Thermal Resistance ( $\theta_{JA}$ )       |                            | 24                        | °C/W  |
| Package Derating above +25°C               |                            | 41.7                      | mW/°C |
| ESD Last Passing Voltage                   | HBM, 1.5k $\Omega$ , 100pF | 8                         | kV    |
|  | LVDS pins to GND only      | 15                        | kV    |
|  | EIAJ, 0 $\Omega$ , 200pF   | 250                       | V     |
|  | CDM                        | 1000                      | V     |

(1) Absolute maximum ratings are those values beyond which damage to the device may occur. The databook specifications should be met, without exception, to ensure that the system design is reliable over its power supply, temperature, and output/input loading variables. National does not recommend operation of products outside of recommended operation conditions.

(2)  $V_{ID}$  max < 2.4V

## Recommended Operating Conditions

|  | Min | Max      | Unit |
|--|-----|----------|------|
| Supply Voltage ( $V_{CC}$ )                | 3.0 | 3.6      | V    |
| Input Voltage ( $V_I$ ) <sup>(1)</sup>     | 0   | $V_{CC}$ | V    |
| Output Voltage ( $V_O$ )                   | 0   | $V_{CC}$ | V    |
| Operating Temperature ( $T_A$ ) Industrial | -40 | +85      | °C   |

(1)  $V_{ID}$  max < 2.4V

## Electrical Characteristics

Over recommended operating supply and temperature ranges unless other specified.

| Symbol   | Parameter                       | Conditions                                | Min          | Typ <sup>(1)</sup> | Max      | Units   |
|--|---------------------------------|---|--------------|--------------------|----------|---------|
| <b>LVTTL DC SPECIFICATIONS (MUX_Sn, PREA_n, PREB_n, PREL_n, ENA_n, ENB_n, ENL_n, TDI, TDO, TCK, TMS, <math>\overline{TRST}</math>)</b> |                                 |   |              |                    |          |         |
| $V_{IH}$   | High Level Input Voltage        |   | 2.0          |                    | $V_{DD}$ | V       |
| $V_{IL}$   | Low Level Input Voltage         |   | GND          |                    | 0.8      | V       |
| $I_{IH}$   | High Level Input Current        | $V_{IN} = V_{DD} = V_{DDMAX}$             | -10          |                    | +10      | $\mu$ A |
| $I_{IHR}$  | High Level Output Current       | PREA_n, PREB_n, PREL_n                    | 40           |                    | 200      | $\mu$ A |
| $I_{IL}$   | Low Level Input Current         | $V_{IN} = V_{SS}, V_{DD} = V_{DDMAX}$     | -10          |                    | +10      | $\mu$ A |
| $I_{ILR}$  | Low Level Input Current         | TDI, TMS, $\overline{TRST}$               | -40          |                    | -200     | $\mu$ A |
| $C_{IN1}$  | Input Capacitance               | Any Digital Input Pin to $V_{SS}$         |              | 2.0                |          | pF      |
| $C_{OUT1}$   | Output Capacitance              | Any Digital Output Pin to $V_{SS}$        |              | 4.0                |          | pF      |
| $V_{CL}$   | Input Clamp Voltage             | $I_{CL} = -18$ mA                         | -1.5         | -0.8               |          | V       |
| $V_{OH}$   | High Level Output Voltage (TDO) | $I_{OH} = -12$ mA, $V_{DD} = 3.0$ V       | 2.4          |                    |          | V       |
|  |                                 | $I_{OH} = -100$ $\mu$ A, $V_{DD} = 3.0$ V | $V_{DD}-0.2$ |                    |          | V       |
| $V_{OL}$   | Low Level Output Voltage (TDO)  | $I_{OL} = 12$ mA, $V_{DD} = 3.0$ V        |              |                    | 0.5      | V       |
|  |                                 | $I_{OL} = 100$ $\mu$ A, $V_{DD} = 3.0$ V  |              |                    | 0.2      | V       |
| $I_{OS}$   | Output Short Circuit Current    | TDO                                       | -15          |                    | -125     | mA      |
| $I_{OZ}$   | Output TRI-STATE Current        | TDO                                       | -10          |                    | +10      | $\mu$ A |

(1) Typical parameters are measured at  $V_{DD} = 3.3$ V,  $T_A = 25^\circ$ C. They are for reference purposes, and are not production-tested.

## Electrical Characteristics (continued)

Over recommended operating supply and temperature ranges unless other specified.

| Symbol   | Parameter  | Conditions   | Min  | Typ <sup>(1)</sup> | Max   | Units |
|--|--|--|------|--------------------|-------|-------|
| <b>LVDS INPUT DC SPECIFICATIONS (SIA<sub>±</sub>, SIB<sub>±</sub>, LI<sub>±</sub>)</b>     |  |  |      |                    |       |       |
| V <sub>TH</sub>  | Differential Input High Threshold <sup>(2)</sup>               | V <sub>CM</sub> = 0.8V or 1.2V or 3.55V,<br>V <sub>DD</sub> = 3.6V   |      | 0                  | 100   | mV    |
| V <sub>TL</sub>  | Differential Input Low Threshold <sup>(2)</sup>                | V <sub>CM</sub> = 0.8V or 1.2V or 3.55V,<br>V <sub>DD</sub> = 3.6V   | -100 | 0                  |       | mV    |
| V <sub>ID</sub>  | Differential Input Voltage                                     | V <sub>CM</sub> = 0.8V to 3.55V, V <sub>DD</sub> = 3.6V  | 100  |                    | 2400  | mV    |
| V <sub>CMR</sub>   | Common Mode Voltage Range                                      | V <sub>ID</sub> = 150 mV, V <sub>DD</sub> = 3.6V   | 0.05 |                    | 3.55  | V     |
| C <sub>IN2</sub>   | Input Capacitance  | IN+ or IN- to V <sub>SS</sub>  |      | 2.0                |       | pF    |
| I <sub>IN</sub>  | Input Current  | V <sub>IN</sub> = 3.6V, V <sub>DD</sub> = V <sub>DDMAX</sub> or 0V   | -15  |                    | +15   | μA    |
|  |  | V <sub>IN</sub> = 0V, V <sub>DD</sub> = V <sub>DDMAX</sub> or 0V   | -15  |                    | +15   | μA    |
| <b>LVDS OUTPUT DC SPECIFICATIONS (SOA<sub>n±</sub>, SOB<sub>n±</sub>, LO<sub>n±</sub>)</b> |  |  |      |                    |       |       |
| V <sub>OD</sub>  | Differential Output Voltage,<br>0% Pre-emphasis <sup>(2)</sup> | R <sub>L</sub> is the internal 100Ω between OUT+<br>and OUT-   | 250  | 360                | 500   | mV    |
| ΔV <sub>OD</sub>   | Change in V <sub>OD</sub> between<br>Complementary States      |  | -35  |                    | 35    | mV    |
| V <sub>OS</sub>  | Offset Voltage <sup>(3)</sup>                                  |  | 1.05 | 1.22               | 1.475 | V     |
| ΔV <sub>OS</sub>   | Change in V <sub>OS</sub> between<br>Complementary States      |  | -35  |                    | 35    | mV    |
| I <sub>OS</sub>  | Output Short Circuit Current                                   | OUT+ or OUT- Short to GND  |      | -21                | -40   | mA    |
| C <sub>OUT2</sub>  | Output Capacitance   | OUT+ or OUT- to GND when TRI-<br>STATE   |      | 4.0                |       | pF    |
| <b>SUPPLY CURRENT (Static)</b>   |  |  |      |                    |       |       |
| I <sub>CC</sub>  | Supply Current   | All inputs and outputs enabled and<br>active, terminated with differential load of<br>100Ω between OUT+ and OUT-       |      | 225                | 275   | mA    |
| I <sub>CCZ</sub>   | Supply Current - Powerdown Mode                                | ENA_0 = ENB_0 = ENL_0 = ENA_1 =<br>ENB_1 = ENL_1 = L   |      | 0.6                | 4.0   | mA    |
| <b>SWITCHING CHARACTERISTICS—LVDS OUTPUTS</b>  |  |  |      |                    |       |       |
| t <sub>LHT</sub>   | Differential Low to High Transition<br>Time                    | Use an alternating 1 and 0 pattern at 200<br>Mb/s, measure between 20% and 80% of<br>V <sub>OD</sub> . <sup>(4)</sup>  |      | 170                | 250   | ps    |
| t <sub>HHT</sub>   | Differential High to Low Transition<br>Time                    |  |      | 170                | 250   | ps    |
| t <sub>PLHD</sub>  | Differential Low to High Propagation<br>Delay                  | Use an alternating 1 and 0 pattern at 200<br>Mb/s, measure at 50% V <sub>OD</sub> between<br>input to output.          |      | 1.0                | 2.5   | ns    |
| t <sub>PHLD</sub>  | Differential High to Low Propagation<br>Delay                  |  |      | 1.0                | 2.5   | ns    |
| t <sub>SKD1</sub>  | Pulse Skew   | t <sub>PLHD</sub> - t <sub>PHLD</sub>   <sup>(4)</sup>   |      | 25                 | 75    | ps    |
| t <sub>SKCC</sub>  | Output Channel to Channel Skew                                 | Difference in propagation delay (t <sub>PLHD</sub> or<br>t <sub>PHLD</sub> ) among all output channels. <sup>(4)</sup> |      | 50                 | 115   | ps    |
| t <sub>JIT</sub>   | Jitter (0% Pre-emphasis) <sup>(5)</sup>                        | RJ - Alternating 1 and 0 at 750MHz <sup>(6)</sup>  |      | 1.1                | 1.5   | psrms |
|  |  | DJ - K28.5 Pattern, 1.5 Gbps <sup>(7)</sup>  |      | 20                 | 34    | psp-p |
|  |  | TJ - PRBS 2 <sup>7</sup> -1 Pattern, 1.5 Gbps <sup>(8)</sup>   |      | 14                 | 28    | psp-p |

(2) Differential output voltage V<sub>OD</sub> is defined as ABS(OUT+–OUT–). Differential input voltage V<sub>ID</sub> is defined as ABS(IN+–IN–).

(3) Output offset voltage V<sub>OS</sub> is defined as the average of the LVDS single-ended output voltages at logic high and logic low states.

(4) Not Production tested. Specified by statistical analysis on a sample basis at the time of characterization.

(5) Jitter is not production tested, but specified through characterization on a sample basis.

(6) Random Jitter, or RJ, is measured RMS with a histogram including 1500 histogram window hits. The input voltage = V<sub>ID</sub> = 500mV, 50% duty cycle at 750MHz, t<sub>r</sub> = t<sub>f</sub> = 50ps (20% to 80%).

(7) Deterministic Jitter, or DJ, is measured to a histogram mean with a sample size of 350 hits. Stimulus and fixture jitter has been subtracted. The input voltage = V<sub>ID</sub> = 500mV, K28.5 pattern at 1.5 Gbps, t<sub>r</sub> = t<sub>f</sub> = 50ps (20% to 80%). The K28.5 pattern is repeating bit streams of (0011111010 1100000101).

(8) Total Jitter, or TJ, is measured peak to peak with a histogram including 3500 window hits. Stimulus and fixture jitter has been subtracted. The input voltage = V<sub>ID</sub> = 500mV, 2<sup>7</sup>-1 PRBS pattern at 1.5 Gbps, t<sub>r</sub> = t<sub>f</sub> = 50ps (20% to 80%).

## Electrical Characteristics (continued)

Over recommended operating supply and temperature ranges unless other specified.

| Symbol   | Parameter                                      | Conditions  | Min  | Typ <sup>(1)</sup> | Max | Units   |
|--|--|---|------|--------------------|-----|---------|
| $t_{ON}$   | LVDS Output Enable Time                        | Time from ENA_n, ENB_n, or ENL_n to OUT $\pm$ change from TRI-STATE to active.              |      | 0.5                | 1.5 | $\mu$ s |
| $t_{ON2}$  | LVDS Output Enable time from powerdown mode    | Time from ENA_n, ENB_n, or ENL_n to OUT $\pm$ change from Powerdown to active               |      | 10                 | 20  | $\mu$ s |
| $t_{OFF}$  | LVDS Output Disable Time                       | Time from ENA_n, ENB_n, or ENL_n to OUT $\pm$ change from active to TRI-STATE or powerdown. |      |                    | 12  | ns      |
| <b>SWITCHING CHARACTERISTICS - SCAN FEATURES</b> |  |   |      |                    |     |         |
| $f_{MAX}$  | Maximum TCK Clock Frequency                    | $R_L = 500\Omega$ ,<br>$C_L = 35\text{ pF}$   | 25.0 |                    |     | MHz     |
| $t_S$  | TDI to TCK, H or L                             |   | 3.0  |                    |     | ns      |
| $t_H$  | TDI to TCK, H or L                             |   | 0.5  |                    |     | ns      |
| $t_S$  | TMS to TCK, H or L                             |   | 3.0  |                    |     | ns      |
| $t_H$  | TMS to TCK, H or L                             |   | 0.5  |                    |     | ns      |
| $t_W$  | TCK Pulse Width, H or L                        |   | 10.0 |                    |     | ns      |
| $t_W$  | $\overline{\text{TRST}}$ Pulse Width, L        |   | 2.5  |                    |     | ns      |
| $t_{REC}$  | Recovery Time, $\overline{\text{TRST}}$ to TCK |   | 2.0  |                    |     | ns      |



## Typical Performance Characteristics

### WQFN Performance Characteristics

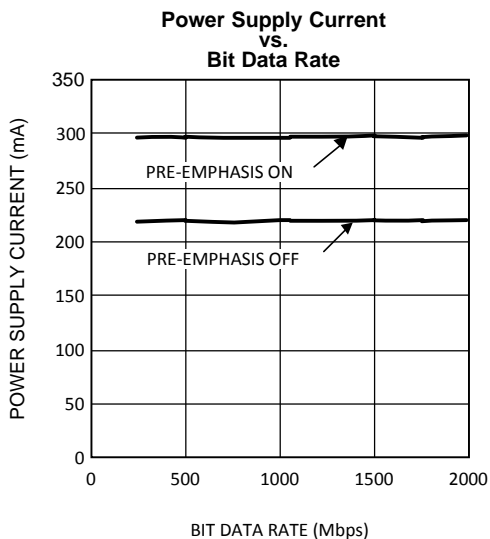

BIT DATA RATE (Mbps)

Dynamic power supply current was measured with all channels active and toggling at the bit data rate. Data pattern has no effect on the power consumption.  $V_{DD} = 3.3V$ ,  $T_A = +25^\circ C$ ,  $V_{ID} = 0.5V$ ,  $V_{CM} = 1.2V$

Figure 2.

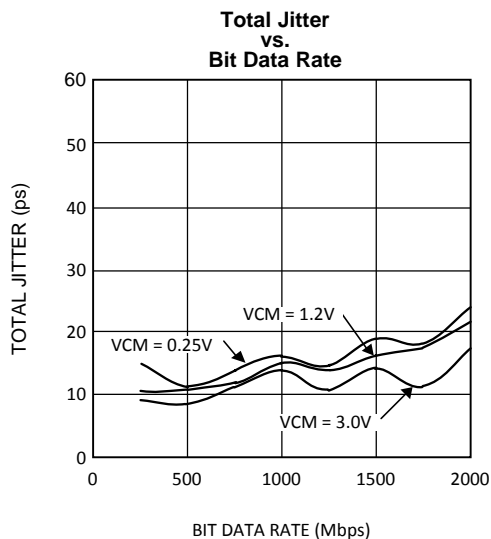

BIT DATA RATE (Mbps)

Total Jitter measured at 0V differential while running a PRBS  $2^{7-1}$  pattern with one channel active, all other channels are disabled.  $V_{DD} = 3.3V$ ,  $T_A = +25^\circ C$ ,  $V_{ID} = 0.5V$ , pre-emphasis off.

Figure 3.

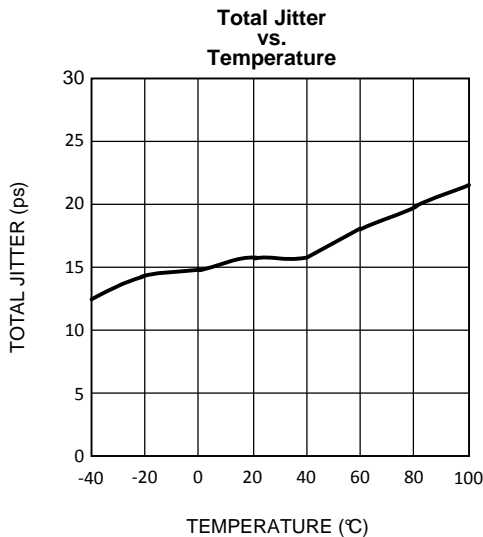

TEMPERATURE (°C)

Total Jitter measured at 0V differential while running a PRBS  $2^{7-1}$  pattern with one channel active, all other channels are disabled.  $V_{DD} = 3.3V$ ,  $V_{ID} = 0.5V$ ,  $V_{CM} = 1.2V$ , 1.5 Gbps data rate, pre-emphasis off.

Figure 4.

## TRI-STATE AND POWERDOWN MODES

The SCAN15MB200 has output enable control on each of the six onboard LVDS output drivers. This control allows each output individually to be placed in a low power TRI-STATE mode while the device remains active, and is useful to reduce power consumption on unused channels. In TRI-STATE mode, some outputs may remain active while some are in TRI-STATE.

When all six of the output enables (all drivers on both channels) are deasserted (LOW), then the device enters a Powerdown mode that consumes only 0.5mA (typical) of supply current. In this mode, the entire device is essentially powered off, including all receiver inputs, output drivers and internal bandgap reference generators. When returning to active mode from Powerdown mode, there is a delay until valid data is presented at the outputs because of the ramp to power up the internal bandgap reference generators.

Any single output enable that remains active will hold the device in active mode even if the other five outputs are in TRI-STATE.

When in Powerdown mode, any output enable that becomes active will wake up the device back into active mode, even if the other five outputs are in TRI-STATE.

### Input Failsafe Biasing

External pull up and pull down resistors may be used to provide enough of an offset to enable an input failsafe under open-circuit conditions. This configuration ties the positive LVDS input pin to VDD thru a pull up resistor and the negative LVDS input pin is tied to GND by a pull down resistor. The pull up and pull down resistors should be in the 5k $\Omega$  to 15k $\Omega$  range to minimize loading and waveform distortion to the driver. Please refer to application note AN-1194 (SNLA051), "Failsafe Biasing of LVDS Interfaces" for more information.

### Interfacing LVPECL to LVDS

An LVPECL driver consists of a differential pair with coupled emitters connected to GND via a current source. This drives a pair of emitter-followers that require a 50 $\Omega$  to  $V_{CC}-2.0$  load. A modern LVPECL driver will typically include the termination scheme within the device for the emitter follower. If the driver does not include the load, then an external scheme must be used. The 1.3 V supply is usually not readily available on a PCB, therefore, a load scheme without a unique power supply requirement may be used.

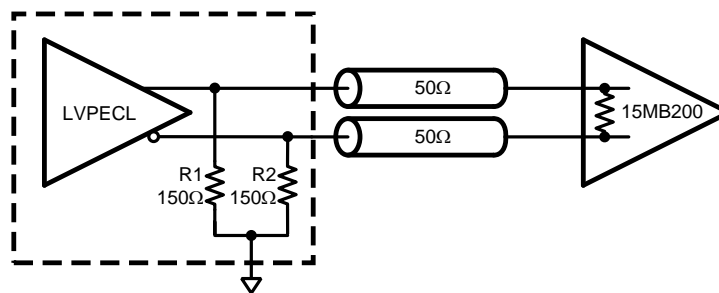

**Figure 5. DC Coupled LVPECL to LVDS Interface**

Figure 5 is a separated  $\pi$  termination scheme for a 3.3 V LVPECL driver. R1 and R2 provides proper DC load for the driver emitter followers, and may be included as part of the driver device.

#### NOTE

The bias networks shown above for LVPECL drivers and receivers may or may not be present within the driver device. The LVPECL driver and receiver specification must be reviewed closely to ensure compatibility between the driver and receiver terminations and common mode operating ranges.

The 15MB200 includes a 100Ω input termination for the transmission line. The common mode voltage will be at the normal LVPECL levels – around 2 V. This scheme works well with LVDS receivers that have rail-to-rail common mode voltage,  $V_{CM}$ , range. Most National Semiconductor LVDS receivers have wide  $V_{CM}$  range. The exceptions are noted in devices' respective datasheets. Those LVDS devices that do have a wide  $V_{CM}$  range do not vary in performance significantly when receiving a signal with a common mode other than standard LVDS  $V_{CM}$  of 1.2 V.

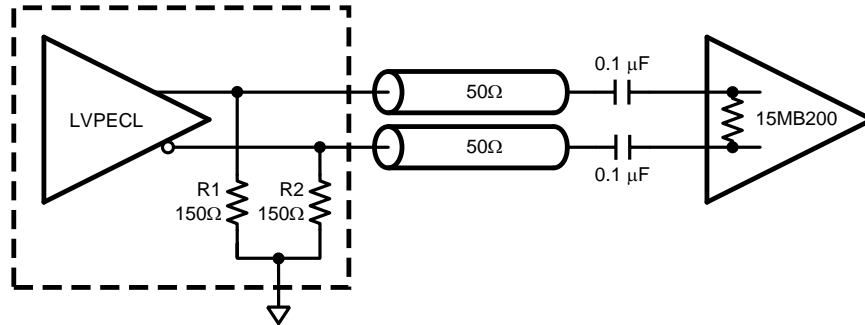

Figure 6. AC Coupled LVPECL to LVDS Interface

An AC coupled interface is preferred when transmitter and receiver ground references differ more than 1 V. This is a likely scenario when transmitter and receiver devices are on separate PCBs. Figure 6 illustrates an AC coupled interface between a LVPECL driver and LVDS receiver. R1 and R2, if not present in the driver device provide DC load for the emitter followers and may range between 140-220Ω for most LVPECL devices for this particular configuration.

**NOTE**

The bias networks shown above for LVPECL drivers and receivers may or may not be present within the driver device. The LVPECL driver and receiver specification must be reviewed closely to ensure compatibility between the driver and receiver terminations and common mode operating ranges.

The 15MB200 includes an internal 100Ω resistor to terminate the transmission line for minimal reflections. The signal after ac coupling capacitors will swing around a level set by internal biasing resistors (i.e. fail-safe) which is either  $V_{DD}/2$  or 0 V depending on the actual failsafe implementation. If internal biasing is not implemented, the signal common mode voltage will slowly drift to GND level.

**Interfacing LVDS to LVPECL**

An LVDS driver consists of a current source (nominal 3.5mA) which drives a CMOS differential pair. It needs a differential resistive load in the range of 70 to 130Ω to generate LVDS levels. In a system, the load should be selected to match transmission line characteristic differential impedance so that the line is properly terminated. The termination resistor should be placed as close to the receiver inputs as possible. When interfacing an LVDS driver with a non-LVDS receiver, one only needs to bias the LVDS signal so that it is within the common mode range of the receiver. This may be done by using separate biasing voltage which demands another power supply. Some receivers have required biasing voltage available on-chip ( $V_T$ ,  $V_{TT}$  or  $V_{BB}$ ).

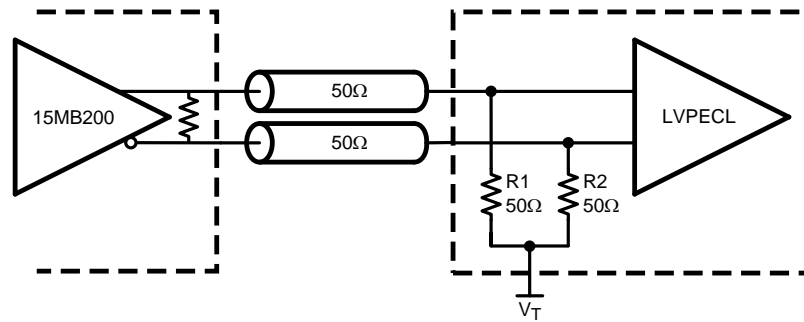
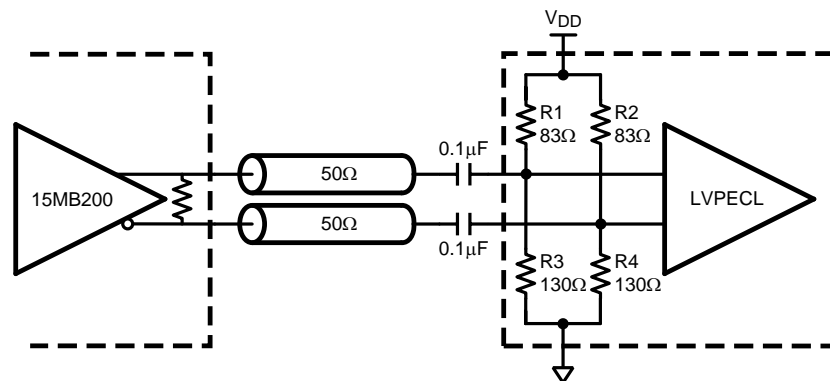

**Figure 7. DC Coupled LVDS to LVPECL Interface**

Figure 7 illustrates interface between an LVDS driver and a LVPECL with a  $V_T$  pin available. R1 and R2, if not present in the receiver, provide proper resistive load for the driver and termination for the transmission line, and  $V_T$  sets desired bias for the receiver.

**NOTE**

The bias networks shown above for LVPECL drivers and receivers may or may not be present within the driver device. The LVPECL driver and receiver specification must be reviewed closely to ensure compatibility between the driver and receiver terminations and common mode operating ranges.



**Figure 8. AC Coupled LVDS to LVPECL Interface**

Figure 8 illustrates AC coupled interface between an LVDS driver and LVPECL receiver without a  $V_T$  pin available. The resistors R1, R2, R3, and R4, if not present in the receiver, provide a load for the driver, terminate the transmission line, and bias the signal for the receiver.

**NOTE**

The bias networks shown above for LVPECL drivers and receivers may or may not be present within the driver device. The LVPECL driver and receiver specification must be reviewed closely to ensure compatibility between the driver and receiver terminations and common mode operating ranges.

## Design-For-Test (DfT) Features

### IEEE 1149.1 SUPPORT

The SCAN15MB200 supports a fully compliant IEEE 1149.1 interface. The Test Access Port (TAP) provides access to boundary scan cells at each LVTTTL I/O on the device for interconnect testing. Differential pins are included in the same boundary scan chain but instead contain IEEE1149.6 cells. IEEE1149.6 is the improved IEEE standard for testing high-speed differential signals.

Refer to the BSDL file located on National's website for the details of the SCAN15MB200 IEEE 1149.1 implementation.

### IEEE 1149.6 SUPPORT

AC-coupled differential interconnections on very high speed (1+ Gbps) data paths are not testable using traditional IEEE 1149.1 techniques. The IEEE 1149.1 structures and methods are intended to test static (DC-coupled), single ended networks. IEEE 1149.6 is specifically designed for testing high-speed differential, including AC coupled networks.

The SCAN15MB200 is intended for high-speed signalling up to 1.5 Gbps and includes IEEE1149.6 on all differential inputs and outputs.

### FAULT INSERTION

Fault Insertion is a technique used to assist in the verification and debug of diagnostic software. During system testing faults are "injected" to simulate hardware failure and thus help verify the monitoring software can detect and diagnose these faults. In the SCAN15MB200 an IEEE1149.1 "stuck-at" instruction can create a stuck-at condition, either high or low, on any pin or combination of pins. A more detailed description of the stuck-at feature can be found in TI Applications note AN-1313 ([SNLA060](#)).

## Packaging Information





The WQFN package is a leadframe based chip scale package (CSP) that may enhance chip speed, reduce thermal impedance, and reduce the printed circuit board area required for mounting. The small size and very low profile make this package ideal for high density PCBs used in small-scale electronic applications such as cellular phones, pagers, and handheld PDAs. The WQFN package is offered in the no Pullback configuration. In the no Pullback configuration the standard solder pads extend and terminate at the edge of the package. This feature offers a visible solder fillet after board mounting.

The WQFN has the following advantages:

- Low thermal resistance
- Reduced electrical parasitics
- Improved board space efficiency
- Reduced package height
- Reduced package mass

For more details about WQFN packaging technology, refer to applications note AN-1187 ([SNOA401](#)), "Leadless Leadframe Package"

## PACKAGING INFORMATION

| Orderable Device     | Status<br>(1) | Package Type | Package<br>Drawing | Pins | Package Qty | Eco Plan<br>(2)            | Lead/Ball Finish | MSL Peak Temp<br>(3) | Op Temp (°C) | Top-Side Markings<br>(4) | Samples   |
|----------------------|---------------|--------------|--------------------|------|-------------|----------------------------|------------------|----------------------|--------------|--------------------------|---|
| SCAN15MB200TSQ       | ACTIVE        | WQFN         | RHS                | 48   | 250         | TBD                        | Call TI          | Call TI              | -40 to 85    |                          |  |
| SCAN15MB200TSQ/NOPB  | ACTIVE        | WQFN         | RHS                | 48   | 250         | Green (RoHS<br>& no Sb/Br) | CU SN            | Level-3-260C-168 HR  | -40 to 85    | 15MB200                  |  |
| SCAN15MB200TSQX      | ACTIVE        | WQFN         | RHS                | 48   | 2500        | TBD                        | Call TI          | Call TI              | -40 to 85    |                          |  |
| SCAN15MB200TSQX/NOPB | ACTIVE        | WQFN         | RHS                | 48   | 2500        | Green (RoHS<br>& no Sb/Br) | CU SN            | Level-3-260C-168 HR  | -40 to 85    | 15MB200                  |  |

(1) The marketing status values are defined as follows:

**ACTIVE:** Product device recommended for new designs.

**LIFEBUY:** TI has announced that the device will be discontinued, and a lifetime-buy period is in effect.

**NRND:** Not recommended for new designs. Device is in production to support existing customers, but TI does not recommend using this part in a new design.

**PREVIEW:** Device has been announced but is not in production. Samples may or may not be available.

**OBSOLETE:** TI has discontinued the production of the device.

(2) Eco Plan - The planned eco-friendly classification: Pb-Free (RoHS), Pb-Free (RoHS Exempt), or Green (RoHS & no Sb/Br) - please check <http://www.ti.com/productcontent> for the latest availability information and additional product content details.

**TBD:** The Pb-Free/Green conversion plan has not been defined.

**Pb-Free (RoHS):** TI's terms "Lead-Free" or "Pb-Free" mean semiconductor products that are compatible with the current RoHS requirements for all 6 substances, including the requirement that lead not exceed 0.1% by weight in homogeneous materials. Where designed to be soldered at high temperatures, TI Pb-Free products are suitable for use in specified lead-free processes.

**Pb-Free (RoHS Exempt):** This component has a RoHS exemption for either 1) lead-based flip-chip solder bumps used between the die and package, or 2) lead-based die adhesive used between the die and leadframe. The component is otherwise considered Pb-Free (RoHS compatible) as defined above.

**Green (RoHS & no Sb/Br):** TI defines "Green" to mean Pb-Free (RoHS compatible), and free of Bromine (Br) and Antimony (Sb) based flame retardants (Br or Sb do not exceed 0.1% by weight in homogeneous material)

(3) MSL, Peak Temp. -- The Moisture Sensitivity Level rating according to the JEDEC industry standard classifications, and peak solder temperature.

(4) Only one of markings shown within the brackets will appear on the physical device.

**Important Information and Disclaimer:** The information provided on this page represents TI's knowledge and belief as of the date that it is provided. TI bases its knowledge and belief on information provided by third parties, and makes no representation or warranty as to the accuracy of such information. Efforts are underway to better integrate information from third parties. TI has taken and continues to take reasonable steps to provide representative and accurate information but may not have conducted destructive testing or chemical analysis on incoming materials and chemicals. TI and TI suppliers consider certain information to be proprietary, and thus CAS numbers and other limited information may not be available for release.

In no event shall TI's liability arising out of such information exceed the total purchase price of the TI part(s) at issue in this document sold by TI to Customer on an annual basis.

**TAPE AND REEL INFORMATION**

**QUADRANT ASSIGNMENTS FOR PIN 1 ORIENTATION IN TAPE**

\*All dimensions are nominal

| Device               | Package Type | Package Drawing | Pins | SPQ  | Reel Diameter (mm) | Reel Width W1 (mm) | A0 (mm) | B0 (mm) | K0 (mm) | P1 (mm) | W (mm) | Pin1 Quadrant |
|----------------------|--------------|-----------------|------|------|--------------------|--------------------|---------|---------|---------|---------|--------|---------------|
| SCAN15MB200TSQ/NOPB  | WQFN         | RHS             | 48   | 250  | 178.0              | 16.4               | 7.3     | 7.3     | 1.3     | 12.0    | 16.0   | Q1            |
| SCAN15MB200TSQX/NOPB | WQFN         | RHS             | 48   | 2500 | 330.0              | 16.4               | 7.3     | 7.3     | 1.3     | 12.0    | 16.0   | Q1            |

TAPE AND REEL BOX DIMENSIONS

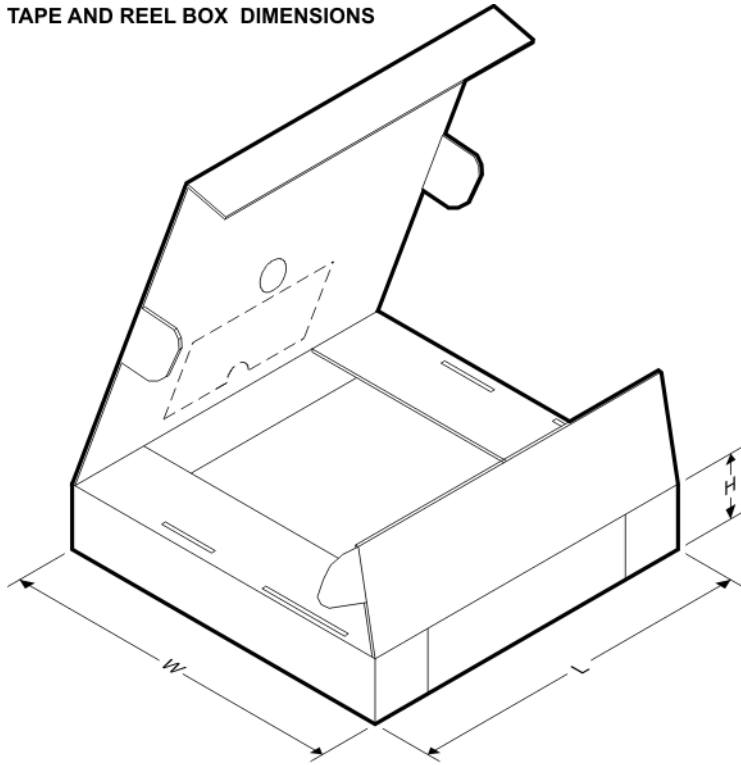

\*All dimensions are nominal

| Device                   | Package Type | Package Drawing | Pins | SPQ  | Length (mm) | Width (mm) | Height (mm) |
|--------------------------|--------------|-----------------|------|------|-------------|------------|-------------|
| SCAN15MB200TSQ/NOPB      | WQFN         | RHS             | 48   | 250  | 213.0       | 191.0      | 55.0        |
| SCAN15MB200TSQX/NOP<br>B | WQFN         | RHS             | 48   | 2500 | 367.0       | 367.0      | 38.0        |



RHS0048A

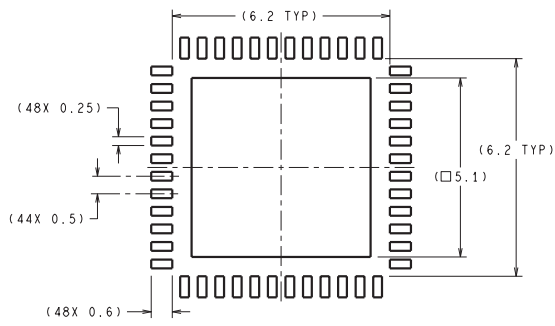

DIMENSIONS ARE IN MILLIMETERS  
DIMENSIONS IN ( ) FOR REFERENCE ONLY

RECOMMENDED LAND PATTERN

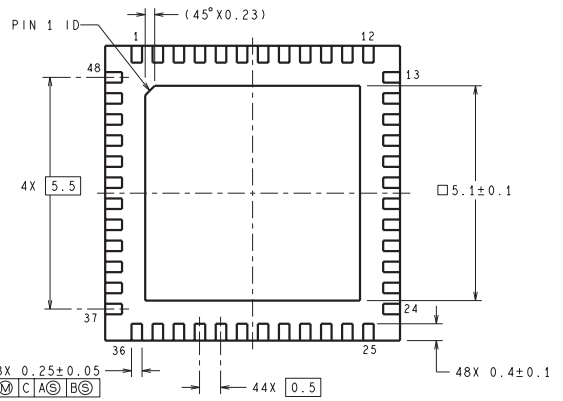
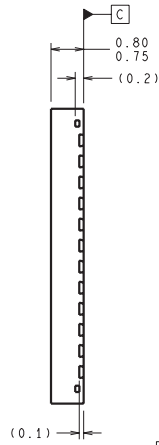
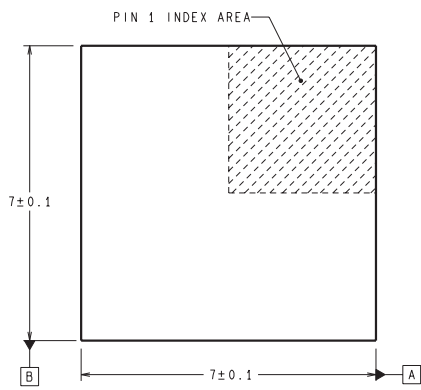

SQA48A (Rev B)

## IMPORTANT NOTICE

Texas Instruments Incorporated and its subsidiaries (TI) reserve the right to make corrections, enhancements, improvements and other changes to its semiconductor products and services per JESD46, latest issue, and to discontinue any product or service per JESD48, latest issue. Buyers should obtain the latest relevant information before placing orders and should verify that such information is current and complete. All semiconductor products (also referred to herein as "components") are sold subject to TI's terms and conditions of sale supplied at the time of order acknowledgment.

TI warrants performance of its components to the specifications applicable at the time of sale, in accordance with the warranty in TI's terms and conditions of sale of semiconductor products. Testing and other quality control techniques are used to the extent TI deems necessary to support this warranty. Except where mandated by applicable law, testing of all parameters of each component is not necessarily performed.

TI assumes no liability for applications assistance or the design of Buyers' products. Buyers are responsible for their products and applications using TI components. To minimize the risks associated with Buyers' products and applications, Buyers should provide adequate design and operating safeguards.

TI does not warrant or represent that any license, either express or implied, is granted under any patent right, copyright, mask work right, or other intellectual property right relating to any combination, machine, or process in which TI components or services are used. Information published by TI regarding third-party products or services does not constitute a license to use such products or services or a warranty or endorsement thereof. Use of such information may require a license from a third party under the patents or other intellectual property of the third party, or a license from TI under the patents or other intellectual property of TI.

Reproduction of significant portions of TI information in TI data books or data sheets is permissible only if reproduction is without alteration and is accompanied by all associated warranties, conditions, limitations, and notices. TI is not responsible or liable for such altered documentation. Information of third parties may be subject to additional restrictions.

Resale of TI components or services with statements different from or beyond the parameters stated by TI for that component or service voids all express and any implied warranties for the associated TI component or service and is an unfair and deceptive business practice. TI is not responsible or liable for any such statements.

Buyer acknowledges and agrees that it is solely responsible for compliance with all legal, regulatory and safety-related requirements concerning its products, and any use of TI components in its applications, notwithstanding any applications-related information or support that may be provided by TI. Buyer represents and agrees that it has all the necessary expertise to create and implement safeguards which anticipate dangerous consequences of failures, monitor failures and their consequences, lessen the likelihood of failures that might cause harm and take appropriate remedial actions. Buyer will fully indemnify TI and its representatives against any damages arising out of the use of any TI components in safety-critical applications.

In some cases, TI components may be promoted specifically to facilitate safety-related applications. With such components, TI's goal is to help enable customers to design and create their own end-product solutions that meet applicable functional safety standards and requirements. Nonetheless, such components are subject to these terms.

No TI components are authorized for use in FDA Class III (or similar life-critical medical equipment) unless authorized officers of the parties have executed a special agreement specifically governing such use.

Only those TI components which TI has specifically designated as military grade or "enhanced plastic" are designed and intended for use in military/aerospace applications or environments. Buyer acknowledges and agrees that any military or aerospace use of TI components which have *not* been so designated is solely at the Buyer's risk, and that Buyer is solely responsible for compliance with all legal and regulatory requirements in connection with such use.

TI has specifically designated certain components as meeting ISO/TS16949 requirements, mainly for automotive use. In any case of use of non-designated products, TI will not be responsible for any failure to meet ISO/TS16949.

### Products

|                              |  |
|------------------------------|--|
| Audio                        | <a href="http://www.ti.com/audio">www.ti.com/audio</a>                               |
| Amplifiers                   | <a href="http://amplifier.ti.com">amplifier.ti.com</a>                               |
| Data Converters              | <a href="http://dataconverter.ti.com">dataconverter.ti.com</a>                       |
| DLP® Products                | <a href="http://www.dlp.com">www.dlp.com</a>   |
| DSP                          | <a href="http://dsp.ti.com">dsp.ti.com</a>   |
| Clocks and Timers            | <a href="http://www.ti.com/clocks">www.ti.com/clocks</a>                             |
| Interface                    | <a href="http://interface.ti.com">interface.ti.com</a>                               |
| Logic                        | <a href="http://logic.ti.com">logic.ti.com</a>                                       |
| Power Mgmt                   | <a href="http://power.ti.com">power.ti.com</a>                                       |
| Microcontrollers             | <a href="http://microcontroller.ti.com">microcontroller.ti.com</a>                   |
| RFID                         | <a href="http://www.ti-rfid.com">www.ti-rfid.com</a>                                 |
| OMAP Applications Processors | <a href="http://www.ti.com/omap">www.ti.com/omap</a>                                 |
| Wireless Connectivity        | <a href="http://www.ti.com/wirelessconnectivity">www.ti.com/wirelessconnectivity</a> |

### Applications

|                               |  |
|-------------------------------|--|
| Automotive and Transportation | <a href="http://www.ti.com/automotive">www.ti.com/automotive</a>                         |
| Communications and Telecom    | <a href="http://www.ti.com/communications">www.ti.com/communications</a>                 |
| Computers and Peripherals     | <a href="http://www.ti.com/computers">www.ti.com/computers</a>                           |
| Consumer Electronics          | <a href="http://www.ti.com/consumer-apps">www.ti.com/consumer-apps</a>                   |
| Energy and Lighting           | <a href="http://www.ti.com/energy">www.ti.com/energy</a>                                 |
| Industrial                    | <a href="http://www.ti.com/industrial">www.ti.com/industrial</a>                         |
| Medical                       | <a href="http://www.ti.com/medical">www.ti.com/medical</a>                               |
| Security                      | <a href="http://www.ti.com/security">www.ti.com/security</a>                             |
| Space, Avionics and Defense   | <a href="http://www.ti.com/space-avionics-defense">www.ti.com/space-avionics-defense</a> |
| Video and Imaging             | <a href="http://www.ti.com/video">www.ti.com/video</a>                                   |

### TI E2E Community

[e2e.ti.com](http://e2e.ti.com)



Компания «ЭлектроПласт» предлагает заключение долгосрочных отношений при поставках импортных электронных компонентов на взаимовыгодных условиях!

Наши преимущества:

- Оперативные поставки широкого спектра электронных компонентов отечественного и импортного производства напрямую от производителей и с крупнейших мировых складов;
- Поставка более 17-ти миллионов наименований электронных компонентов;
- Поставка сложных, дефицитных, либо снятых с производства позиций;
- Оперативные сроки поставки под заказ (от 5 рабочих дней);
- Экспресс доставка в любую точку России;
- Техническая поддержка проекта, помощь в подборе аналогов, поставка прототипов;
- Система менеджмента качества сертифицирована по Международному стандарту ISO 9001;
- Лицензия ФСБ на осуществление работ с использованием сведений, составляющих государственную тайну;
- Поставка специализированных компонентов (Xilinx, Altera, Analog Devices, Intersil, Interpoint, Microsemi, Aeroflex, Peregrine, Syfer, Eurofarad, Texas Instrument, Miteq, Cobham, E2V, MA-COM, Hittite, Mini-Circuits, General Dynamics и др.);

Помимо этого, одним из направлений компании «ЭлектроПласт» является направление «Источники питания». Мы предлагаем Вам помощь Конструкторского отдела:

- Подбор оптимального решения, техническое обоснование при выборе компонента;
- Подбор аналогов;
- Консультации по применению компонента;
- Поставка образцов и прототипов;
- Техническая поддержка проекта;
- Защита от снятия компонента с производства.



#### Как с нами связаться

**Телефон:** 8 (812) 309 58 32 (многоканальный)

**Факс:** 8 (812) 320-02-42

**Электронная почта:** [org@eplast1.ru](mailto:org@eplast1.ru)

**Адрес:** 198099, г. Санкт-Петербург, ул. Калинина, дом 2, корпус 4, литера А.