

XCM517 Series

600mA Synchronous Dual Output Step-Down DC/DC Converters

GENERAL DESCRIPTION

The XCM517 series is a multi combination module IC which comprises of two 600mA driver transistor built-in synchronous step-down DC/DC converter. The XCM517 series is available in an ultra small package USP-12B01 suited for space conscious applications.

The XCM517 series is a group of synchronous-rectification type DC/DC converters with a built-in 0.42 P-channel driver transistor and 0.52 N-channel switching transistor, designed to allow the use of ceramic capacitors. The ICs enable a high efficiency, stable power supply with an output current of 600mA to be configured using only a coil and two capacitors connected externally. Operating voltage range is from 2.7V to 6.0V. With the built-in oscillator, either 1.2MHz or 3.0MHz can be selected for suiting to your particular application. As for operation mode, the XCM517xA / XCM517xB series are PWM control, the XCM517xC / XCM517xD series are automatic PWM/PFM switching control, allowing fast response, low ripple and high efficiency over the full range of loads (from light load to heavy load).

The soft start and current control functions are internally optimized. During stand-by, all circuits are shutdown to reduce current consumption to as low as 1.0 μ A or less. With the built-in UVLO (Under Voltage Lock Out) function, the internal P-channel driver transistor is forced OFF when input voltage becomes 1.4V or lower.

APPLICATIONS

Mobile phones, Smart phones
Bluetooth equipment
Personal Device Assistancess
Portable games
Digital still cameras, camcorders

FEATURES

P-ch Driver Transistor Built-In	: ON resistance 0.42 Ω
N-ch Driver Transistor Built-In	: ON resistance 0.52 Ω
Input Voltage Range	: 2.7V ~ 6.0V
High Efficiency	: 92% (TYP.)
Output Current	: 600mA
Oscillation Frequency	: 1.2MHz, 3.0MHz (\pm 15%)
Maximum Duty Cycle	: 100%
Soft-Start Circuit Built-In	
Current Limiter Circuit Built-In	(Constant Current & Latching)
Ceramic Capacitor Compatible	
Control Methods	: PWM (XCM517xA / XCM517xB) PWM/PFM Auto (XCM517xC / XCM517xD)

TYPICAL APPLICATION CIRCUIT



*Performance depends on external components and wiring on the PCB.

Combination of voltage	1 ch	2ch
XCM517xx01D	1.2V	1.8V
XCM517xx02D	1.2V	3.3V
XCM517xx03D	1.8V	3.3V
XCM517xx06D	1.5V	1.8V
XCM517xx07D	1.5V	3.3V

*The other combination of voltage is semi-custom.

* The dotted lines in the circuit indicates the connection using through-holes at the backside of the PC board

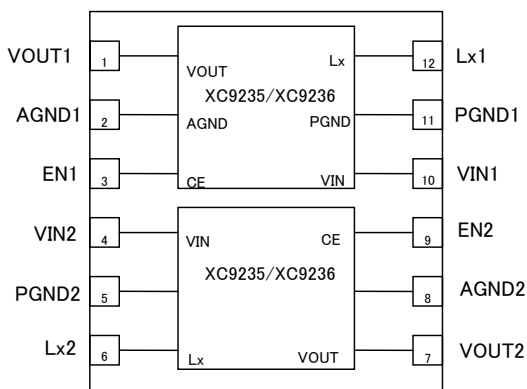

(TOP VIEW)

PIN CONFIGURATION



USP-12B01
(BOTTOM VIEW)

PIN ASSIGNMENT

PIN NUMBER	PIN NAME			FUNCTIONS
	USP-12B01	XCM517	XC9235/XC9236	
1	V _{OUT1}	V _{OUT}	—	DC/DC-1 Channel Block: Output Voltage sense
2	AGND1	AGND	—	DC/DC-1 Channel Block: Analog Ground
3	EN1	CE	—	DC/DC-1 Channel Block: ON/OFF Control
4	V _{IN2}	—	V _{IN}	DC/DC-2 Channel Block: Power Input
5	PGND2	—	PGND	DC/DC-2 Channel Block : Power Ground
6	Lx2	—	Lx	DC/DC-2 Channel Block : Switching
7	V _{OUT2}	—	V _{OUT}	DC/DC-2 Channel Block : Output Voltage sense
8	AGND2	—	AGND	DC/DC-2 Channel Block : Analog Ground
9	EN2	—	CE	DC/DC-2 Channel Block : ON/OFF Control
10	V _{IN1}	V _{IN}	—	DC/DC-1 Channel Block : Power Input
11	PGND1	PGND	—	DC/DC-1 Channel Block : Power Ground
12	Lx1	Lx	—	DC/DC-1 Channel Block : Switching

NOTE:

* A dissipation pad on the reverse side of the package should be electrically isolated.

*1: Electrical potential of the DC/DC 1 channels' dissipation pad should be V_{SS} level.

*2: Electrical potential of the DC/DC 2 channels' dissipation pad should be V_{SS} level.

Care must be taken for an electrical potential of each dissipation pad so as to enhance mounting strength and heat release when the pad needs to be connected to the circuit.

PRODUCT CLASSIFICATION

Ordering Information

XCM517

DESIGNATOR	DESCRIPTION	SYMBOL	DESCRIPTION
	Control, Oscillation Frequency and Options	-	: See the chart below
	Output Voltage	-	: Internally set sequential number relating to output voltage (See the chart below)
	Package	D	: USP-12B01
	Device Orientation	R	: Embossed tape, standard feed

DESIGNATOR

	CONTROL	OCSILLATION FREQUENCY	CL DISCHARGE	HIGH SPEED SOFT-START	EN INPUT LOGIC
AA	PWM Control	1.2M	Not Available	Not Available	High Active
AB	PWM Control	3.0M	Not Available	Not Available	High Active
AC	PWM/PFM Auto	1.2M	Not Available	Not Available	High Active
AD	PWM/PFM Auto	3.0M	Not Available	Not Available	High Active
BA	PWM Control	1.2M	Available	Available	High Active
BB	PWM Control	3.0M	Available	Available	High Active
BC	PWM/PFM Auto	1.2M	Available	Available	High Active
BD	PWM/PFM Auto	3.0M	Available	Available	High Active

DESIGNATOR Output Voltage

	V _{OUT1}	V _{OUT2}
01	1.2	1.8
02	1.2	3.3
03	1.8	3.3
06	1.5	1.8
07	1.5	3.3

*This series are semi-custom products. For other combinations, output voltages and etc., please ask Torex sales contacts.

BLOCK DIAGRAMS

XC9235A / XC9236A Series



XC9235B / XC9236B Series

Available with CL Discharge, High Speed Soft-Start

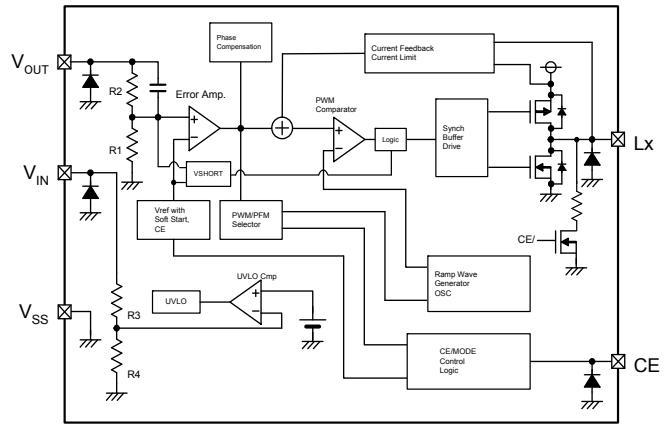

NOTE: The signal from CE/MODE Control Logic to PWM/PFM Selector is being fixed to "L" level inside, and XC9235 series chooses only PWM control.

The signal from CE/MODE Control Logic to PWM/PFM Selector is being fixed to "H" level inside, and XC9236 series chooses only PWM/PFM automatic switching control.

Diodes inside the circuit are ESD protection diodes and parasitic diodes.

*Diodes inside the circuit are an ESD protection diode and a parasitic diode.

MAXIMUM ABSOLUTE RATINGS

PARAMETER	SYMBOL	RATINGS	UNITS
V_{IN1} / V_{IN2} Voltage	V_{IN1} / V_{IN2}	- 0.3 ~ 6.5	V
L_{X1} / L_{X2} Voltage	V_{LX1} / V_{LX2}	- 0.3 ~ $V_{IN1} + 0.3$ or 6.5	V
V_{OUT1} / V_{OUT2} Voltage	V_{OUT1} / V_{OUT2}	- 0.3 ~ 6.5	V
EN1 / EN2 Voltage	V_{EN1} / V_{EN2}	- 0.3 ~ 6.5	V
L_{X1} / L_{X2} Current	I_{LX1} / I_{LX2}	± 1500	mA
Power Dissipation ($T_a=25^\circ\text{C}$)	USP-12B01	P_d	150
Junction Temperature	T_j	125	
Operating Temperature Range	T_{opr}	- 40 ~ + 85	
Storage Temperature Range	T_{stg}	- 55 ~ + 125	

ELECTRICAL CHARACTERISTICS

XCM517Ax, 1ch Block /2ch Block $V_{OUT}=1.8V$, $f_{OSC}=1.2MHz$, $T_a=25^{\circ}C$

PARAMETER	SYMBOL	CONDITIONS	MIN.	TYP.	MAX.	UNITS	CIRCUIT
Output Voltage	V_{OUT}	When connected to external components, $V_{IN}=V_{EN}=5.0V$, $I_{OUT1}=30mA$	1.764	1.800	1.836	V	
Operating Voltage Range	V_{IN}		2.7	-	6.0	V	
Maximum Output Current	I_{OUTMAX}	When connected to external components, $V_{IN}=V_{OUT(E)}+2.0V$, $V_{EN}=1.0V$ ^{(*)8}	600	-	-	mA	
UVLO Voltage	V_{UVLO}	$V_{EN}=V_{IN}$, $V_{OUT}=0V$, Voltage which Lx pin holding "L" level ^{(*)1, (*)10}	1.00	1.40	1.78	V	
Supply Current	I_{DD}	$V_{IN}=V_{EN}=5.0V$, $V_{OUT}=V_{OUT(E)} \times 1.1V$ (XCM517AA) (XCM517AC)	-	22	50	μA	
Stand-by Current	I_{STB}	$V_{IN}=5.0V$, $V_{EN}=0V$, $V_{OUT}=V_{OUT(E)} \times 1.1V$	-	0	1.0	μA	
Oscillation Frequency	f_{OSC}	When connected to external components, $V_{IN}=V_{OUT(E)}+2.0V$, $V_{EN}=1.0V$, $I_{OUT}=100mA$	1020	1200	1380	kHz	
PFM Switching Current	I_{PFM}	When connected to external components, $V_{IN}=V_{OUT(E)}+2.0V$, $V_{EN}=V_{IN}$, $I_{OUT}=1mA$ ^{(*)11}	120	160	200	mA	
Maximum I_{PFM} Limit	MAX I_{PFM}	$V_{EN}=V_{IN}=(C-1)$ $I_{OUT}=1mA$ ^{(*)11}		200		%	
Maximum Duty Ratio	MAXDTY	$V_{IN}=V_{EN}=5.0V$, $V_{OUT}=V_{OUT(E)} \times 0.9V$	100	-	-	%	
Minimum Duty Ratio	MINDTY	$V_{IN}=V_{EN}=5.0V$, $V_{OUT}=V_{OUT(E)} \times 1.1V$	-	-	0	%	
Efficiency ^{(*)2}	EFFI	When connected to external components, $V_{EN}=V_{IN}=V_{OUT(E)}+1.2V$ ^{(*)7} , $I_{OUT}=100mA$	-	92	-	%	
Lx SW "H" ON Resistance 1	R_{LxH}	$V_{IN}=V_{EN}=5.0V$, $V_{OUT}=0V$, $I_{Lx}=100mA$ ^{(*)3}	-	0.35	0.55		
Lx SW "H" ON Resistance 2	R_{LxH}	$V_{IN}=V_{EN}=3.6V$, $V_{OUT}=0V$, $I_{Lx}=100mA$ ^{(*)3}	-	0.42	0.67		
Lx SW "L" ON Resistance 1	R_{LxL}	$V_{IN}=V_{EN}=5.0V$ ^{(*)4}	-	0.45	0.66		-
Lx SW "L" ON Resistance 2	R_{LxL}	$V_{IN}=V_{EN}=3.6V$ ^{(*)4}	-	0.52	0.77		-
Lx SW "H" Leak Current ^{(*)5}	I_{LeakH}	$V_{IN}=V_{OUT}=5.0V$, $V_{EN}=0V$, $Lx=0V$	-	0.01	1.0	μA	
Lx SW "L" Leak Current ^{(*)5}	I_{LeakL}	$V_{IN}=V_{OUT}=5.0V$, $V_{EN}=0V$, $Lx=5.0V$	-	0.01	1.0	μA	
Current Limit ^{(*)9}	I_{LIM}	$V_{IN}=V_{EN}=5.0V$, $V_{OUT}=V_{OUT(E)} \times 0.9V$ ^{(*)7}	900	1050	1350	mA	
Output Voltage Temperature Characteristics	$\frac{V_{OUT}}{V_{OUT} \cdot t_{opr}}$	$I_{OUT}=30mA$ -40 T_{opr} 85	-	± 100	-	ppm/	
EN "H" Level Voltage	V_{ENH}	$V_{OUT}=0V$, Applied voltage to V_{EN} , Voltage changes Lx to "H" level ^{(*)10}	0.65	-	6.0	V	
EN "L" Level Voltage	V_{ENL}	$V_{OUT}=0V$, Applied voltage to V_{EN} , Voltage changes Lx to "L" level ^{(*)10}	V_{SS}	-	0.25	V	
EN "H" Current	I_{ENH}	$V_{IN}=V_{EN}=5.0V$, $V_{OUT}=0V$	- 0.1	-	0.	μA	
EN "L" Current	I_{ENL}	$V_{IN}=5.0V$, $V_{EN}=0V$, $V_{OUT}=0V$	- 0.1	-	0.1	μA	
Soft Start Time	t_{SS}	When connected to external components, $V_{EN}=0V \rightarrow V_{IN}$, $I_{OUT}=1mA$	0.5	1.0	2.5	ms	
Latch Time	t_{LAT}	$V_{IN}=V_{EN}=5.0V$, $V_{OUT}=0.8 \times V_{OUT(E)}$, Short Lx at 1 Ω resistance ^{(*)6}	1.0	-	20.0	ms	
Short Protection Threshold Voltage	V_{SHORT}	Sweeping V_{OUT} , $V_{IN}=V_{EN}=5.0V$, Short Lx at 1 Ω resistance, V_{OUT} voltage which Lx becomes "L" level within 1ms	0.675	0.900	1.125	V	

Test conditions: Unless otherwise stated, $V_{IN} = 5.0V$, $V_{OUT(E)} =$ Setting voltage

NOTE:

- *1: Including hysteresis width of operating voltage.
- *2: $EFFI = \{ (\text{output voltage} \times \text{output current}) / (\text{input voltage} \times \text{input current}) \} \times 100$
- *3: ON resistance () = $(V_{IN} - Lx \text{ pin measurement voltage}) / 100mA$
- *4: Design value
- *5: When temperature is high, a current of approximately 10 μA (maximum) may leak.
- *6: Time until it short-circuits DC_{OUT} with GND via 1 of resistor from an operational state and is set to $Lx=0V$ from current limit pulse generating.
- *7: When $V_{OUT(E)}+1.2V < 2.7V$, $V_{IN}=2.7V$
- *8: When the difference between the input and the output is small, some cycles may be skipped completely before current maximizes.
If current is further pulled from this state, output voltage will decrease because of P-ch driver ON resistance.
- *9: Current limit denotes the level of detection at peak of coil current.
- *10: "H" = $V_{IN} - 1.2V$, "L" = $+ 0.1V \sim - 0.1V$
- *11: XCM517xA / XCM517xB series exclude I_{PFM} and $MAXI_{PFM}$ because those are only for the PFM control's functions.
- *12: The electrical characteristics shows 1 channel values when the other channel is stopped.

ELECTRICAL CHARACTERISTICS (Continued)

XCM517Ax, 1ch Block / 2ch Block $V_{OUT}=1.8V$, $f_{OSC}=3.0MHz$, $T_a=25^{\circ}C$

PARAMETER	SYMBOL	CONDITIONS	MIN.	TYP.	MAX.	UNITS	CIRCUIT
Output Voltage	V_{OUT}	When connected to external components, $V_{IN}=V_{EN}=5.0V$, $I_{OUT1}=30mA$	1.764	1.800	1.836	V	
Operating Voltage Range	V_{IN}		2.7	-	6.0	V	
Maximum Output Current	I_{OUTMAX}	When connected to external components, $V_{IN}=V_{OUT(E)}+2.0V$, $V_{EN}=1.0V$ ⁽⁸⁾	600	-	-	mA	
UVLO Voltage	V_{UVLO}	$V_{EN}=V_{IN}$, $V_{OUT}=0V$, Voltage which Lx pin holding "L" level ^(1, *10)	1.00	1.40	1.78	V	
Supply Current	I_{DD}	$V_{IN}=V_{EN}=5.0V$, $V_{OUT}=V_{OUT(E)} \times 1.1V$ (XCM517AB) (XCM517AD)	-	46	65	μA	
Stand-by Current	I_{STB}	$V_{IN}=5.0V$, $V_{EN}=0V$, $V_{OUT}=V_{OUT(E)} \times 1.1V$	-	0	1.0	μA	
Oscillation Frequency	f_{OSC}	When connected to external components, $V_{IN}=V_{OUT(E)}+2.0V$, $V_{EN}=1.0V$, $I_{OUT}=100mA$	2550	3000	3450	kHz	
PFM Switching Current	I_{PFM}	When connected to external components, $V_{IN}=V_{OUT(E)}+2.0V$, $V_{EN}=V_{IN}$, $I_{OUT}=1mA$ ⁽¹¹⁾	170	220	270	mA	
Maximum I_{PFM} Limit	MAX I_{PFM}	$V_{EN}=V_{IN}=(C-1) I_{OUT}=1mA$ ⁽¹¹⁾		200	300	%	
Maximum Duty Ratio	MAXDTY	$V_{IN}=V_{EN}=5.0V$, $V_{OUT}=V_{OUT(E)} \times 0.9V$	100	-	-	%	
Minimum Duty Ratio	MINDTY	$V_{IN}=V_{EN}=5.0V$, $V_{OUT}=V_{OUT(E)} \times 1.1V$	-	-	0	%	
Efficiency ⁽²⁾	EFFI	When connected to external components, $V_{EN}=V_{IN}=V_{OUT(E)}+1.2V$ ⁽⁷⁾ , $I_{OUT}=100mA$	-	86	-	%	
Lx SW "H" ON Resistance 1	R_{LxH}	$V_{IN}=V_{EN}=5.0V$, $V_{OUT}=0V$, $I_{Lx}=100mA$ ⁽³⁾	-	0.35	0.55		
Lx SW "H" ON Resistance 2	R_{LxH}	$V_{IN}=V_{EN}=3.6V$, $V_{OUT}=0V$, $I_{Lx}=100mA$ ⁽³⁾	-	0.42	0.67		
Lx SW "L" ON Resistance 1	R_{LxL}	$V_{IN}=V_{EN}=5.0V$ ⁽⁴⁾	-	0.45	0.66		-
Lx SW "L" ON Resistance 2	R_{LxL}	$V_{IN}=V_{EN}=3.6V$ ⁽⁴⁾	-	0.52	0.77		-
Lx SW "H" Leak Current ⁽⁵⁾	I_{LeakH}	$V_{IN}=V_{OUT}=5.0V$, $V_{EN}=0V$, $Lx=0V$	-	0.01	1.0	μA	
Lx SW "L" Leak Current ⁽⁵⁾	I_{LeakL}	$V_{IN}=V_{OUT}=5.0V$, $V_{EN}=0V$, $Lx=5.0V$	-	0.01	1.0	μA	
Current Limit ⁽⁹⁾	I_{LIM}	$V_{IN}=V_{EN}=5.0V$, $V_{OUT}=V_{OUT(E)} \times 0.9V$ ⁽⁷⁾	900	1050	1350	mA	
Output Voltage Temperature Characteristics	$\frac{V_{OUT}}{V_{OUT} \cdot T_{opr}}$	$I_{OUT}=30mA$ -40 T_{opr} 85	-	± 100	-	ppm/	
EN "H" Level Voltage	V_{ENH}	$V_{OUT}=0V$, Applied voltage to V_{EN} , Voltage changes Lx to "H" level ⁽¹⁰⁾	0.65	-	6.0	V	
EN "L" Level Voltage	V_{ENL}	$V_{OUT}=0V$, Applied voltage to V_{EN} , Voltage changes Lx to "L" level ⁽¹⁰⁾	V_{SS}	-	0.25	V	
EN "H" Current	I_{ENH}	$V_{IN}=V_{EN}=5.0V$, $V_{OUT}=0V$	- 0.1	-	0.	μA	
EN "L" Current	I_{ENL}	$V_{IN}=5.0V$, $V_{EN}=0V$, $V_{OUT}=0V$	- 0.1	-	0.1	μA	
Soft Start Time	t_{SS}	When connected to external components, $V_{EN}=0V \rightarrow V_{IN}$, $I_{OUT}=1mA$	0.5	1.0	2.5	ms	
Latch Time	t_{LAT}	$V_{IN}=V_{EN}=5.0V$, $V_{OUT}=0.8 \times V_{OUT(E)}$, Short Lx at 1Ω resistance ⁽⁶⁾	1.0	-	20.0	ms	
Short Protection Threshold Voltage	V_{SHORT}	Sweeping V_{OUT} , $V_{IN}=V_{EN}=5.0V$, Short Lx at 1Ω resistance, V_{OUT} voltage which Lx becomes "L" level within 1ms	0.675	0.900	1.125	V	

Test conditions: Unless otherwise stated, $V_{IN} = 5.0V$, $V_{OUT(E)} =$ Setting voltage

NOTE:

*1: Including hysteresis width of operating voltage.

*2: $EFFI = \{ (\text{output voltage} \times \text{output current}) / (\text{input voltage} \times \text{input current}) \} \times 100$

*3: ON resistance () = $(V_{IN} - Lx \text{ pin measurement voltage}) / 100mA$

*4: Design value

*5: When temperature is high, a current of approximately $10 \mu A$ (maximum) may leak.

*6: Time until it short-circuits DC_{OUT} with GND via 1 of resistor from an operational state and is set to $Lx=0V$ from current limit pulse generating.

*7: When $V_{OUT(E)}+1.2V < 2.7V$, $V_{IN}=2.7V$

*8: When the difference between the input and the output is small, some cycles may be skipped completely before current maximizes.
If current is further pulled from this state, output voltage will decrease because of P-ch driver ON resistance.

*9: Current limit denotes the level of detection at peak of coil current.

*10: "H" = $V_{IN} \sim V_{IN} - 1.2V$, "L" = $+ 0.1V \sim - 0.1V$

*11: XCM517xA / XCM517xB series exclude I_{PFM} and $MAXI_{PFM}$ because those are only for the PFM control's functions.

*12: The electrical characteristics shows 1 channel values when the other channel is stopped.

ELECTRICAL CHARACTERISTICS (Continued)

XCM517Bx, 1ch Block / 2ch Block $V_{OUT}=1.8V$, $f_{OSC}=1.2MHz$, $T_a=25^{\circ}C$

PARAMETER	SYMBOL	CONDITIONS	MIN.	TYP.	MAX.	UNITS	CIRCUIT
Output Voltage	V_{OUT}	When connected to external components, $V_{IN}=V_{EN}=5.0V$, $I_{OUT1}=30mA$	1.764	1.800	1.836	V	
Operating Voltage Range	V_{IN}		2.7	-	6.0	V	
Maximum Output Current	I_{OUTMAX}	When connected to external components, $V_{IN}=V_{OUT(E)}+2.0V$, $V_{EN}=1.0V$ ⁽⁸⁾	600	-	-	mA	
UVLO Voltage	V_{UVLO}	$V_{EN}=V_{IN}$, $V_{OUT}=0V$, Voltage which Lx pin holding "L" level ^(1, *10)	1.00	1.40	1.78	V	
Supply Current	I_{DD}	$V_{IN}=V_{EN}=5.0V$, $V_{OUT}=V_{OUT(E)}\times 1.1V$ (XCM517BA) (XCM517BC)	-	22	50	μA	
Stand-by Current	I_{STB}	$V_{IN}=5.0V$, $V_{EN}=0V$, $V_{OUT}=V_{OUT(E)}\times 1.1V$	-	0	1.0	μA	
Oscillation Frequency	f_{OSC}	When connected to external components, $V_{IN}=V_{OUT(E)}+2.0V$, $V_{EN}=1.0V$, $I_{OUT}=100mA$	1020	1200	1380	kHz	
PFM Switching Current	I_{PFM}	When connected to external components, $V_{IN}=V_{OUT(E)}+2.0V$, $V_{EN}=V_{IN}$, $I_{OUT}=1mA$ ⁽¹¹⁾	120	160	200	mA	
Maximum I_{PFM} Limit	MAX I_{PFM}	$V_{EN}=V_{IN}=(C-1)$ $I_{OUT}=1mA$ ⁽¹¹⁾		200		%	
Maximum Duty Ratio	MAXDTY	$V_{IN}=V_{EN}5.0V$, $V_{OUT}=V_{OUT(E)}\times 0.9V$	100	-	-	%	
Minimum Duty Ratio	MINDTY	$V_{IN}=V_{EN}5.0V$, $V_{OUT}=V_{OUT(E)}\times 1.1V$	-	-	0	%	
Efficiency ⁽²⁾	EFFI	When connected to external components, $V_{EN}=V_{IN}=V_{OUT(E)}+1.2V$ ⁽⁷⁾ , $I_{OUT}=100mA$	-	92	-	%	
Lx SW "H" ON Resistance 1	R_{LxH}	$V_{IN}=V_{EN}=5.0V$, $V_{OUT}=0V$, $I_{Lx}=100mA$ ⁽³⁾	-	0.35	0.55		
Lx SW "H" ON Resistance 2	R_{LxH}	$V_{IN}=V_{EN}=3.6V$, $V_{OUT}=0V$, $I_{Lx}=100mA$ ⁽³⁾	-	0.42	0.67		
Lx SW "L" ON Resistance 1	R_{LxL}	$V_{IN}=V_{EN}=5.0V$ ⁽⁴⁾	-	0.45	0.66		-
Lx SW "L" ON Resistance 2	R_{LxL}	$V_{IN}=V_{EN}=3.6V$, ⁽⁴⁾	-	0.52	0.77		-
Lx SW "H" Leak Current ⁽⁵⁾	I_{LeakH}	$V_{IN}=V_{OUT}=5.0V$, $V_{EN}=0V$, $Lx=0V$	-	0.01	1.0	μA	
Current Limit ⁽⁹⁾	I_{LIM}	$V_{IN}=V_{EN}=5.0V$, $V_{OUT}=V_{OUT(E)}\times 0.9V$ ⁽⁷⁾	900	1050	1350	mA	
Output Voltage Temperature Characteristics	$\frac{V_{OUT}}{V_{OUT} \cdot T_{opr}}$	$I_{OUT}=30mA$ -40 T_{opr} 85	-	± 100	-	ppm/	
EN "H" Level Voltage	V_{ENH}	$V_{OUT}=0V$, Applied voltage to V_{EN} , Voltage changes Lx to "H" level ⁽¹⁰⁾	0.65	-	6.0	V	
EN "L" Level Voltage	V_{ENL}	$V_{OUT}=0V$, Applied voltage to V_{EN} , Voltage changes Lx to "L" level ⁽¹⁰⁾	V_{SS}	-	0.25	V	
EN "H" Current	I_{ENH}	$V_{IN}=V_{EN}=5.0V$, $V_{OUT}=0V$	- 0.1	-	0.	μA	
EN "L" Current	I_{ENL}	$V_{IN}=5.0V$, $V_{EN}=0V$, $V_{OUT}=0V$	- 0.1	-	0.1	μA	
Soft Start Time	t_{SS}	When connected to external components, $V_{EN}=0V \rightarrow V_{IN}$, $I_{OUT}=1mA$	-	0.25	0.4	ms	
Latch Time	t_{LAT}	$V_{IN}=V_{EN}=5.0V$, $V_{OUT}=0.8 \times V_{OUT(E)}$, Short Lx at 1Ω resistance ⁽⁶⁾	1.0	-	20.0	ms	
Short Protection Threshold Voltage	V_{SHORT}	Sweeping V_{OUT} , $V_{IN}=V_{EN}=5.0V$, Short Lx at 1Ω resistance, V_{OUT} voltage which Lx becomes "L" level within 1ms	0.675	0.900	1.125	V	
C L Discharge	R_{dischg}	$V_{IN}=5.0V$ $Lx=5.0V$ $V_{EN}=0V$ $V_{OUT}=open$	200	300	450		

Test conditions: Unless otherwise stated, $V_{IN}=5.0V$, $V_{OUT(E)}$ = Setting voltage

NOTE:

- *1: Including hysteresis width of operating voltage.
- *2: $EFFI = \{ (output\ voltage \times output\ current) / (input\ voltage \times input\ current) \} \times 100$
- *3: ON resistance () = $(V_{IN} - Lx\ pin\ measurement\ voltage) / 100mA$
- *4: Design value
- *5: When temperature is high, a current of approximately 10 μA (maximum) may leak.
- *6: Time until it short-circuits DC_{OUT} with GND via 1 of resistor from an operational state and is set to $Lx=0V$ from current limit pulse generating.
- *7: When $V_{OUT(E)}+1.2V < 2.7V$, $V_{IN}=2.7V$
- *8: When the difference between the input and the output is small, some cycles may be skipped completely before current maximizes.
If current is further pulled from this state, output voltage will decrease because of P-ch driver ON resistance.
- *9: Current limit denotes the level of detection at peak of coil current.
- *10: "H" = $V_{IN} - V_{IN} - 1.2V$, "L" = $+ 0.1V \sim - 0.1V$
- *11: XCM517xA / XCM517xB series exclude I_{PFM} and $MAXI_{PFM}$ because those are only for the PFM control's functions.
- *12: The electrical characteristics shows 1 channel values when the other channel is stopped.

ELECTRICAL CHARACTERISTICS (Continued)

XCM517Bx, 1ch Block /2ch Block $V_{OUT}=1.8V$, $f_{OSC}=3.0MHz$, $T_a=25^{\circ}C$

PARAMETER	SYMBOL	CONDITIONS	MIN.	TYP.	MAX.	UNITS	CIRCUIT
Output Voltage	V_{OUT}	When connected to external components, $V_{IN}=V_{EN}=5.0V$, $I_{OUT1}=30mA$	1.764	1.800	1.836	V	
Operating Voltage Range	V_{IN}		2.7	-	6.0	V	
Maximum Output Current	I_{OUTMAX}	When connected to external components, $V_{IN}=V_{OUT(E)}+2.0V$, $V_{EN}=1.0V$ ⁽⁸⁾	600	-	-	mA	
UVLO Voltage	V_{UVLO}	$V_{EN}=V_{IN}$, $V_{OUT}=0V$, Voltage which Lx pin holding "L" level ^(1, *10)	1.00	1.40	1.78	V	
Supply Current	I_{DD}	$V_{IN}=V_{EN}=5.0V$, $V_{OUT}=V_{OUT(E)}\times 1.1V$ (XCM517BB) (XCM517BD)	-	46	65	μA	
Stand-by Current	I_{STB}	$V_{IN}=5.0V$, $V_{EN}=0V$, $V_{OUT}=V_{OUT(E)}\times 1.1V$	-	0	1.0	μA	
Oscillation Frequency	f_{OSC}	When connected to external components, $V_{IN}=V_{OUT(E)}+2.0V$, $V_{EN}=1.0V$, $I_{OUT}=100mA$	2550	3000	3450	kHz	
PFM Switching Current	I_{PFM}	When connected to external components, $V_{IN}=V_{OUT(E)}+2.0V$, $V_{EN}=V_{IN}$, $I_{OUT}=1mA$ ⁽¹¹⁾	170	220	270	mA	
Maximum I_{PFM} Limit	MAX I_{PFM}	$V_{EN}=V_{IN}=(C-1) I_{OUT}=1mA$ ⁽¹¹⁾	-	200	300	%	
Maximum Duty Ratio	MAXDTY	$V_{IN}=V_{EN}=5.0V$, $V_{OUT}=V_{OUT(E)}\times 0.9V$	100	-	-	%	
Minimum Duty Ratio	MINDTY	$V_{IN}=V_{EN}=5.0V$, $V_{OUT}=V_{OUT(E)}\times 1.1V$	-	-	0	%	
Efficiency ⁽²⁾	EFFI	When connected to external components, $V_{EN}=V_{IN}=V_{OUT(E)}+1.2V$ ⁽⁷⁾ , $I_{OUT}=100mA$	-	92	-	%	
Lx SW "H" ON Resistance 1	R_{LxH}	$V_{IN}=V_{EN}=5.0V$, $V_{OUT}=0V$, $I_{Lx}=100mA$ ⁽³⁾	-	0.35	0.55		
Lx SW "H" ON Resistance 2	R_{LxH}	$V_{IN}=V_{EN}=3.6V$, $V_{OUT}=0V$, $I_{Lx}=100mA$ ⁽³⁾	-	0.42	0.67		
Lx SW "L" ON Resistance 1	R_{LxL}	$V_{IN}=V_{EN}=5.0V$ ⁽⁴⁾	-	0.45	0.66		-
Lx SW "L" ON Resistance 2	R_{LxL}	$V_{IN}=V_{EN}=3.6V$ ⁽⁴⁾	-	0.52	0.77		-
Lx SW "H" Leak Current ⁽⁵⁾	I_{LeakH}	$V_{IN}=V_{OUT}=5.0V$, $V_{EN}=0V$, $Lx=0V$	-	0.01	1.0	μA	
Current Limit ⁽⁹⁾	I_{LIM}	$V_{IN}=V_{EN}=5.0V$, $V_{OUT}=V_{OUT(E)}\times 0.9V$ ⁽⁷⁾	900	1050	1350	mA	
Output Voltage Temperature Characteristics	$\frac{V_{OUT}}{V_{OUT} \cdot top_r}$	$I_{OUT}=30mA$ -40 Top_r 85	-	± 100	-	ppm/	
EN "H" Level Voltage	V_{ENH}	$V_{OUT}=0V$, Applied voltage to V_{EN} , Voltage changes Lx to "H" level ⁽¹⁰⁾	0.65	-	6.0	V	
EN "L" Level Voltage	V_{ENL}	$V_{OUT}=0V$, Applied voltage to V_{EN} , Voltage changes Lx to "L" level ⁽¹⁰⁾	V_{SS}	-	0.25	V	
EN "H" Current	I_{ENH}	$V_{IN}=V_{EN}=5.0V$, $V_{OUT}=0V$	- 0.1	-	0.	μA	
EN "L" Current	I_{ENL}	$V_{IN}=5.0V$, $V_{EN}=0V$, $V_{OUT}=0V$	- 0.1	-	0.1	μA	
Soft Start Time	t_{SS}	When connected to external components, $V_{EN}=0V \rightarrow V_{IN}$, $I_{OUT}=1mA$	-	0.32	0.5	ms	
Latch Time	t_{LAT}	$V_{IN}=V_{EN}=5.0V$, $V_{OUT}=0.8 \times V_{OUT(E)}$, Short Lx at 1Ω resistance ⁽⁶⁾	1.0	-	20.0	ms	
Short Protection Threshold Voltage	V_{SHORT}	Sweeping V_{OUT} , $V_{IN}=V_{EN}=5.0V$, Short Lx at 1Ω resistance, V_{OUT} voltage which Lx becomes "L" level within 1ms	0.675	0.900	1.125	V	
C L Discharge	R_{dischg}	$V_{IN}=5.0V$ $Lx=5.0V$ $V_{EN}=0V$ $V_{OUT}=open$	200	300	450		

Test conditions: Unless otherwise stated, $V_{IN}=5.0V$, $V_{OUT(E)}$ = Setting voltage

NOTE:

- *1: Including hysteresis width of operating voltage.
- *2: $EFFI = \{ (output\ voltage \times output\ current) / (input\ voltage \times input\ current) \} \times 100$
- *3: ON resistance () = $(V_{IN} - Lx\ pin\ measurement\ voltage) / 100mA$
- *4: Design value
- *5: When temperature is high, a current of approximately 10 μA (maximum) may leak.
- *6: Time until it short-circuits DC_{OUT} with GND via 1 of resistor from an operational state and is set to $Lx=0V$ from current limit pulse generating.
- *7: When $V_{OUT(E)}+1.2V < 2.7V$, $V_{IN}=2.7V$
- *8: When the difference between the input and the output is small, some cycles may be skipped completely before current maximizes.
If current is further pulled from this state, output voltage will decrease because of P-ch driver ON resistance.
- *9: Current limit denotes the level of detection at peak of coil current.
- *10: "H" = $V_{IN} \sim V_{IN} - 1.2V$, "L" = $+ 0.1V \sim - 0.1V$
- *11: XCM517xA / XCM517xB series exclude I_{PFM} and $MAXI_{PFM}$ because those are only for the PFM control's functions.
- *12: The electrical characteristics shows 1 channel values when the other channel is stopped.

ELECTRICAL CHARACTERISTICS (Continued)

PFM Switching Current (I_{PFM}) by Oscillation Frequency and Setting Voltage

(mA)

SETTING VOLTAGE	1.2MHz			3.0MHz		
	MIN.	TYP.	MAX.	MIN.	TYP.	MAX.
$V_{OUT(E)} \leq 1.2V$	140	180	240	190	260	350
$1.2V < V_{OUT(E)} \leq 1.75V$	130	170	220	180	240	300
$1.8V \leq V_{OUT(E)}$	120	160	200	170	220	270

Input Voltage (V_{IN}) for Measuring Maximum PFM Switching Current ($MAXI_{PFM}$) Limit

f_{OSC}	1.2MHz	3.0MHz
(C-1)	$V_{OUT(E)}+0.5V$	$V_{OUT(E)}+1.0V$

Minimum operating voltage is 2.7V.

ex.) Although when $V_{OUT(E)} = 1.2V$, $f_{OSC} = 1.2MHz$, (C-1) = 1.7V, the (C-1) becomes 2.7V because of the minimum operating voltage 2.7V.

Soft-start time by each setting voltage (XCM517Bx series only)

PRODUCT SERIES	f_{OSC}	SETTING VOLTAGE	MIN.	TYP.	MAX.
XC517BA	1200kHz	0.8 $V_{OUT(E)} < 1.5$	-	250	400 μs
	1200kHz	1.5 $V_{OUT(E)} < 1.8$	-	320	500 μs
	1200kHz	1.8 $V_{OUT(E)} < 2.5$	-	250	400 μs
	1200kHz	2.5 $V_{OUT(E)} 4.0$	-	320	500 μs
XC517BC	1200kHz	0.8 $V_{OUT(E)} < 2.5$	-	250	400 μs
	1200kHz	2.5 $V_{OUT(E)} 4.0$	-	320	500 μs
XC517BB	3000kHz	0.8 $V_{OUT(E)} < 1.8$	-	250	400 μs
XC517BD	3000kHz	1.8 $V_{OUT(E)} 4.0$	-	320	500 μs

TYPICAL APPLICATION CIRCUIT



$f_{osc}=3.0\text{MHz}$

L1/L2: 1.5 μH (NR3015 TAIYO YUDEN)

CIN1/CIN2: 4.7 μF (Ceramic)

CL1/CL2 : 10 μF (Ceramic)

$f_{osc}=1.2\text{MHz}$

L1/L2: 4.7 μH (NR4018 TAIYO YUDEN)

CIN1/CIN2: 4.7 μF (Ceramic)

CL1/CL2 : 10 μF (Ceramic)

OPERATIONAL DESCRIPTION

The XCM517 series consists of a reference voltage source, ramp wave circuit, error amplifier, PWM comparator, phase compensation circuit, output voltage adjustment resistors, P-channel MOSFET driver transistor, N-channel MOSFET switching transistor for the synchronous switch, current limiter circuit, UVLO circuit and others. (See the block diagram above.) The series ICs compare, using the error amplifier, the voltage of the internal voltage reference source with the feedback voltage from the V_{OUT} pin through split resistors, R1 and R2. Phase compensation is performed on the resulting error amplifier output, to input a signal to the PWM comparator to determine the turn-on time during PWM operation. The PWM comparator compares, in terms of voltage level, the signal from the error amplifier with the ramp wave from the ramp wave circuit, and delivers the resulting output to the buffer driver circuit to cause the Lx pin to output a switching duty cycle. This process is continuously performed to ensure stable output voltage. The current feedback circuit monitors the P-channel MOS driver transistor current for each switching operation, and modulates the error amplifier output signal to provide multiple feedback signals. This enables a stable feedback loop even when a low ESR capacitor such as a ceramic capacitor is used ensuring stable output voltage.

<Reference Voltage Source>

The reference voltage source provides the reference voltage to ensure stable output voltage of the DC/DC converter.

<Ramp Wave Circuit>

The ramp wave circuit determines switching frequency. The frequency is fixed internally and can be selected from 1.2MHz or 3.0MHz. Clock pulses generated in this circuit are used to produce ramp waveforms needed for PWM operation, and to synchronize all the internal circuits.

<Error Amplifier>

The error amplifier is designed to monitor output voltage. The amplifier compares the reference voltage with the feedback voltage divided by the internal split resistors, R1 and R2. When a voltage lower than the reference voltage is fed back, the output voltage of the error amplifier signal increases. The gain and frequency characteristics of the error amplifier output are fixed internally to deliver an optimized signal to the mixer.

<Current Limit>

The current limiter circuit of the XCM517 series monitors the current flowing through the P-channel MOS driver transistor connected to the Lx pin, and features a combination of the current limit mode and the operation suspension mode.

When the driver current is greater than a specific level, the current limit function operates to turn off the pulses from the Lx pin at any given timing.

When the driver transistor is turned off, the limiter circuit is then released from the current limit detection state.

At the next pulse, the driver transistor is turned on. However, the transistor is immediately turned off in the case of an over current state.

When the over current state is eliminated, the IC resumes its normal operation.

The IC waits for the over current state to end by repeating the steps through . If an over current state continues for a few ms and the above three steps are repeatedly performed, the IC performs the function of latching the OFF state of the driver transistor, and goes into operation suspension mode. Once the IC is in suspension mode, operations can be resumed by either turning the IC off via the EN pin, or by restoring power to the V_{IN} pin. The suspension mode does not mean a complete shutdown, but a state in which pulse output is suspended; therefore, the internal circuitry remains in operation. The current limit of the XCM517 series can be set at 1050mA at typical. Depending on the state of the PC Board, latch time may become longer and latch operation may not work. In order to avoid the effect of noise, the board should be laid out so that input capacitors are placed as close to the IC as possible.



OPERATIONAL DESCRIPTION (Continued)

<Short-Circuit Protection>

The short-circuit protection circuit monitors the internal R1 and R2 divider voltage from the V_{OUT} pin (refer to FB point in the block diagram shown in the previous page). In case where output is accidentally shorted to the Ground and when the FB point voltage decreases less than half of the reference voltage (V_{ref}) and a current more than the I_{LIM} flows to the driver transistor, the short-circuit protection quickly operates to turn off and to latch the driver transistor. In latch mode, the operation can be resumed by either turning the IC off and on via the EN pin, or by restoring power supply to the V_{IN} pin.

When sharp load transient happens, a voltage drop at the V_{OUT} is propagated to the FB point through C_{FB} , as a result, short circuit protection may operate in the voltage higher than $1/2 V_{OUT}$ voltage.

< UVLO Circuit>

When the V_{IN} pin voltage becomes 1.4V or lower, the P-channel output driver transistor is forced OFF to prevent false pulse output caused by unstable operation of the internal circuitry. When the V_{IN} pin voltage becomes 1.8V or higher, switching operation takes place. By releasing the UVLO function, the IC performs the soft start function to initiate output startup operation. The soft start function operates even when the V_{IN} pin voltage falls momentarily below the UVLO operating voltage. The UVLO circuit does not cause a complete shutdown of the IC, but causes pulse output to be suspended; therefore, the internal circuitry remains in operation.

<PFM Switch Current>

In PFM control operation, until coil current reaches to a specified level (I_{PFM}), the IC keeps the P-ch MOSFET on. In this case, time that the P-ch MOSFET is kept on (t_{ON}) can be given by the following formula.

$$t_{ON} = L \times I_{PFM} / (V_{IN} - V_{OUT}) \quad I_{PFM}$$

<Maximum I_{PFM} Limit>

In PFM control operation, the maximum duty ratio ($MAXI_{PFM}$) is set to 200% (TYP.). Therefore, under the condition that the duty increases (e.g. the condition that the step-down ratio is small), it's possible for P-ch MOSFET to be turned off even when coil current doesn't reach to I_{PFM} . I_{PFM}



OPERATIONAL DESCRIPTION (Continued)

< C_L High Speed Discharge >

The XCM517Bx series can quickly discharge the electric charge at the output capacitor (C_L) when a low signal to the EN pin which enables a whole IC circuit put into OFF state, is inputted via the N-channel transistor located between the L_X pin and the V_{SS} pin. When the IC is disabled, electric charge at the output capacitor (C_L) is quickly discharged so that it may avoid application malfunction. Discharge time of the output capacitor (C_L) is set by the C_L auto-discharge resistance (R) and the output capacitor (C_L). By setting time constant of a C_L auto-discharge resistance value [R] and an output capacitor value (C_L) as $\tau = C \times R$, discharge time of the output voltage after discharge via the N channel transistor is calculated by the following formulas.

$$V = V_{OUT(E)} \times e^{-t/\tau}, \text{ or } t = \tau \ln(V_{OUT(E)} / V)$$

V : Output voltage after discharge

V_{OUT(E)} : Output voltage

t: Discharge time,

$\tau = C \times R$

C= Capacitance of Output capacitor (C_L)

R= C_L auto-discharge resistance

Output Voltage Discharge Characteristics
R_{dischg} = 300 Ω (TYP)



OPERATIONAL DESCRIPTION (Continued)

<EN Pin Function>

The operation of the XCM517 series will enter into the shut down mode when a low level signal is input to the EN pin. During the shutdown mode, the current consumption of the IC becomes $0 \mu\text{A}$ (TYP.), with a state of high impedance at the Lx pin and Vout pin. The IC starts its operation by inputting a high level signal to the EN pin. The input to the EN pin is a CMOS input and the sink current is $0 \mu\text{A}$ (TYP.).

XCM517 series - Examples of how to use EN pin

(A)

SW_EN	STATUS
ON	Stand-by
OFF	Operation

(B)

SW_EN	STATUS
ON	Operation
OFF	Stand-by

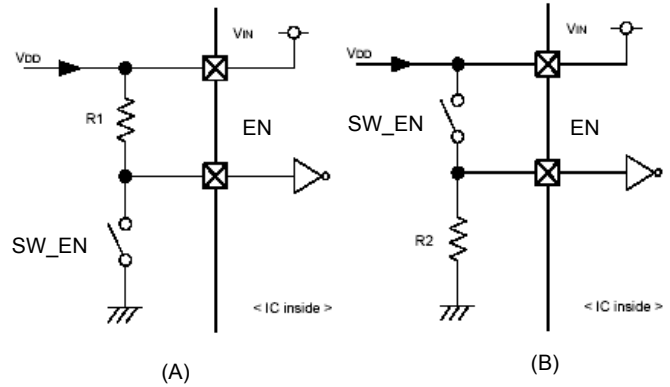

< Soft Start >

Soft start time is available in two options via product selection.

The XCM517Ax series provide 1.0ms (TYP). The XCM517Bx series provide 0.25ms (TYP). Soft start time is defined as the time to reach 90% of the output setting voltage when the V_{EN} pin is turned on.



FUNCTION CHART

EN VOLTAGE LEVEL	OPERATIONAL STATES	
	XCM517xA/XCM517xB	XCM517xC/XCM517xD
H Level ^(*1)	Synchronous PWM Fixed Control	Synchronous PWM/PFM Automatic Switching
L Level ^(*2)	Stand-by	Stand-by

Note on EN pin voltage level range

(*1) H level: $0.65V \leq H \text{ level} \leq V_{IN}$

(*2) L level: $0V \leq L \text{ level} \leq 0.25V$

NOTE ON USE

- The XCM517 series is designed for use with ceramic output capacitors. If, however, the potential difference is too large between the input voltage and the output voltage, a ceramic capacitor may fail to absorb the resulting high switching energy and oscillation could occur on the output. If the input-output potential difference is large, connect an electrolytic capacitor in parallel to compensate for insufficient capacitance.
- Spike noise and ripple voltage arise in a switching regulator as with a DC/DC converter. These are greatly influenced by external component selection, such as the coil inductance, capacitance values, and board layout of external components. Once the design has been completed, verification with actual components should be done.
- Depending on the input-output voltage differential, or load current, some pulses may be skipped, and the ripple voltage may increase.
- When the difference between V_{IN} and V_{OUT} is large in PWM control, very narrow pulses will be outputted, and there is the possibility that some cycles may be skipped completely.
- When the difference between V_{IN} and V_{OUT} is small, and the load current is heavy, very wide pulses will be outputted and there is the possibility that some cycles may be skipped completely.
- With the IC, the peak current of the coil is controlled by the current limit circuit. Since the peak current increases when dropout voltage or load current is high, current limit starts operation, and this can lead to instability. When peak current becomes high, please adjust the coil inductance value and fully check the circuit operation. In addition, please calculate the peak current according to the following formula:

$$I_{pk} = (V_{IN} - V_{OUT}) \times \text{OnDuty} / (2 \times L \times f_{OSC}) + I_{OUT}$$
 L: Coil Inductance Value
 f_{OSC} : Oscillation Frequency
- When the peak current which exceeds limit current flows within the specified time, the built-in P-ch driver transistor turns off. During the time until it detects limit current and before the built-in transistor can be turned off, the current for limit current flows; therefore, care must be taken when selecting the rating for the external components such as a coil.
- Care must be taken when laying out the PC Board, in order to prevent misoperation of the current limit mode. Depending on the state of the PC Board, latch time may become longer and latch operation may not work. In order to avoid the effect of noise, the board should be laid out so that input capacitors are placed as close to the IC as possible.
- Use of the IC at voltages below the recommended voltage range may lead to instability.

NOTE ON USE (Continued)

10. This IC should be used within the stated absolute maximum ratings in order to prevent damage to the device.
11. When the IC is used in high temperature, output voltage may increase up to input voltage level at no load because of the leak current of the driver transistor.
12. The current limit is set to 1350mA (MAX.) at typical. However, the current of 1350mA or more may flow. In case that the current limit functions while the V_{OUT} pin is shorted to the GND pin, when P-ch MOSFET is ON, the potential difference for input voltage will occur at both ends of a coil. For this, the time rate of coil current becomes large. By contrast, when N-ch MOSFET is ON, there is almost no potential difference at both ends of the coil since the V_{OUT} pin is shorted to the GND pin. Consequently, the time rate of coil current becomes quite small. According to the repetition of this operation, and the delay time of the circuit, coil current will be converged on a certain current value, exceeding the amount of current, which is supposed to be limited originally. Even in this case, however, after the over current state continues for several ms, the circuit will be latched. A coil should be used within the stated absolute maximum rating in order to prevent damage to the device.

Current flows into P-ch MOSFET to reach the current limit (I_{LIM}).

The current of I_{LIM} or more flows since the delay time of the circuit occurs during from the detection of the current limit to OFF of P-ch MOSFET.

Because of no potential difference at both ends of the coil, the time rate of coil current becomes quite small.

L_x oscillates very narrow pulses by the current limit for several ms.

The circuit is latched, stopping its operation.



13. In order to stabilize V_{IN} voltage level and oscillation frequency, we recommend that a by-pass capacitor (C_{IN}) be connected as close as possible to the V_{IN} and V_{SS} pins.
14. High step-down ratio and very light load may lead an intermittent oscillation.
15. During PWM / PFM automatic switching mode, operating may become unstable at transition to continuous mode. Please verify with actual parts.

V_{OUT}=3.3V, F_{OSC}=1.2MHz
V_{IN}=3.7V, I_{OUT}=100mA



External Components
L : 4.7 μH(NR4018)
C_{IN} : 4.7 μF(Ceramic)
C_L : 10 μF(Ceramic)

NOTE ON USE (Continued)

16. Please note the inductance value of the coil. The IC may enter unstable operation if the combination of ambient temperature, setting voltage, oscillation frequency, and L value are not adequate. In the operation range close to the maximum duty cycle, The IC may happen to enter unstable output voltage operation even if using the L values listed below.



●The Range of L Value

f _{OSC}	V _{OUT}	L Value
3.0MHz	0.8V < V _{OUT} < 4.0V	1.0 µH ~ 2.2 µH
1.2MHz	V _{OUT} ≤ 2.5V	3.3 µH ~ 6.8 µH
	2.5V < V _{OUT}	4.7 µH ~ 6.8 µH

*When a coil less value of 4.7 µH is used at f_{OSC}=1.2MHz or when a coil less value of 1.5 µH is used at f_{OSC}=3.0MHz, peak coil current more easily reach the current limit I_{LMI}. In this case, it may happen that the IC can not provide 600mA output current.

17. It may happen to enter unstable operation when the IC operation mode goes into continuous operation mode under the condition of small input-output voltage difference. Care must be taken with the actual design unit.



Instructions of pattern layouts

1. In order to stabilize V_{IN} voltage level, we recommend that a by-pass capacitor (C_{IN}) be connected as close as possible to the V_{IN} & V_{SS} pins.
2. Please mount each external component as close to the IC as possible.
3. Wire external components as close to the IC as possible and use thick, short connecting traces to reduce the circuit impedance.
4. Make sure that the PCB GND traces are as thick as possible, as variations in ground potential caused by high ground currents at the time of switching may result in instability of the IC.
5. This series' internal driver transistors bring on heat because of the output current and ON resistance of driver transistors.

TEST CIRCUITS

< Circuit No.1 >



※ External Components

L : 1.5μH(NRFD15) 3.0MHz
4.7μH(NR4015) 1.2MHz

CIN : 4.7μF(ceramic)
CL : 10μF(ceramic)

< Circuit No.2 >

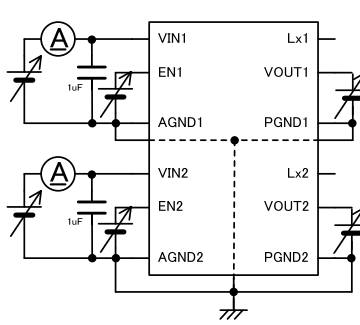

< Circuit No.3 >

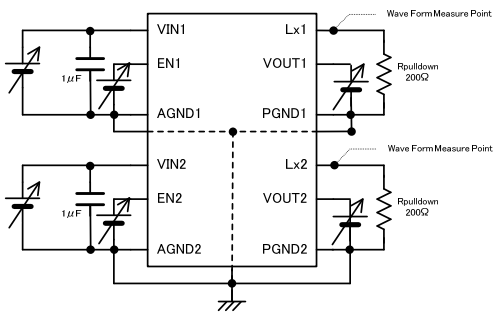

< Circuit No.4 >

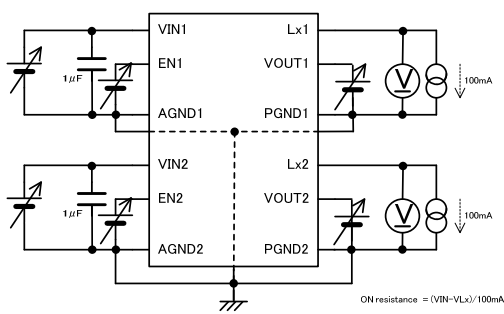

ON resistance = (VIN-VLx)/100mA

< Circuit No.5 >

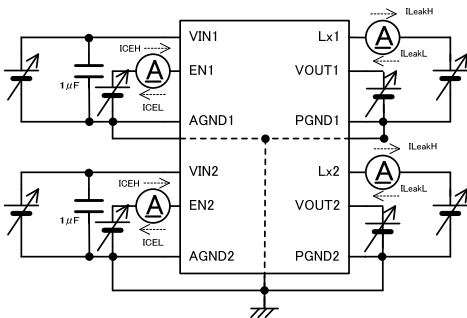

< Circuit No.6 >

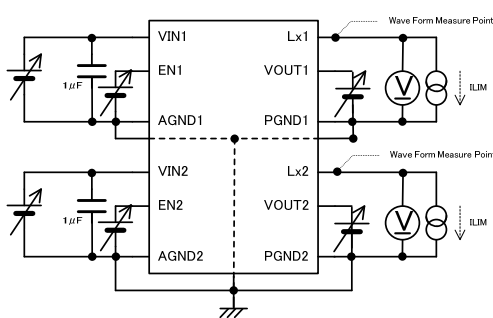

< Circuit No.7 >

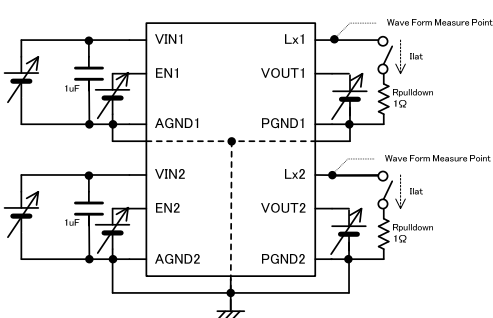

< Circuit No.8 >

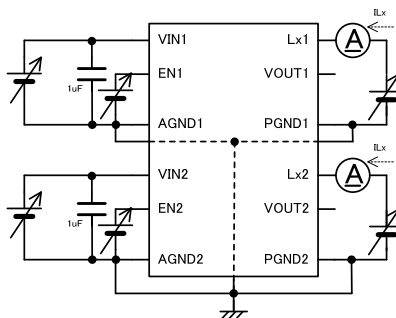

< Circuit No.9 >

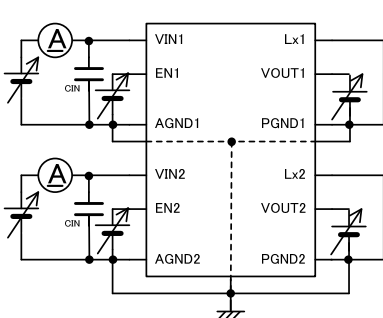

TYPICAL PERFORMANCE CHARACTERISTICS

(1) Efficiency vs. Output Current

$V_{OUT}=1.8V, 1.2MHz$

$L=4.7\mu H(NR4018), C_{IN}=4.7\mu F, C_L=10\mu F$



$V_{OUT}=1.8V, 3.0MHz$

$L=1.5\mu H(NR3015), C_{IN}=4.7\mu F, C_L=10\mu F$



(2) Output Voltage vs. Output Current

$V_{OUT}=1.8V, 1.2MHz$

$L=4.7\mu H(NR4018), C_{IN}=4.7\mu F, C_L=10\mu F$



$V_{OUT}=1.8V, 3.0MHz$

$L=1.5\mu H(NR3015), C_{IN}=4.7\mu F, C_L=10\mu F$



(3) Ripple Voltage vs. Output Current

$V_{OUT}=1.8V, 1.2MHz$

$L=4.7\mu H(NR4018), C_{IN}=4.7\mu F, C_L=10\mu F$

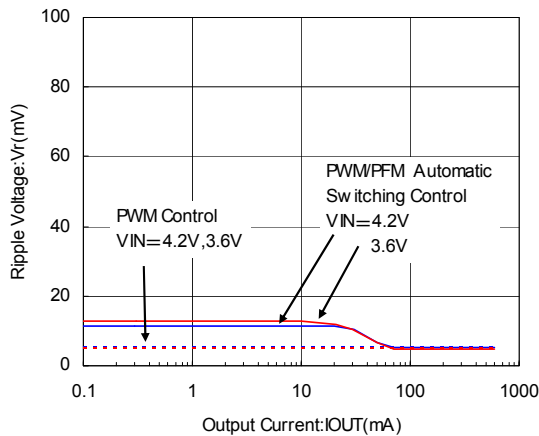

$V_{OUT}=1.8V, 3.0MHz$

$L=1.5\mu H(NR3015), C_{IN}=4.7\mu F, C_L=10\mu F$

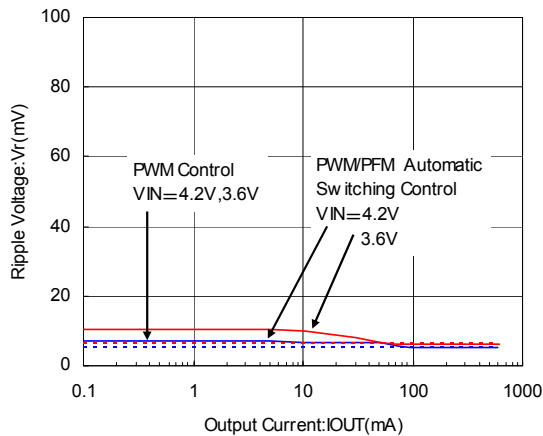

TYPICAL PERFORMANCE CHARACTERISTICS (Continued)

(4) Oscillation Frequency vs. Ambient Temperature

$V_{OUT}=1.8V, 1.2MHz$

$L=4.7\mu H(NR4018), C_{IN}=4.7\mu F, C_L=10\mu F$

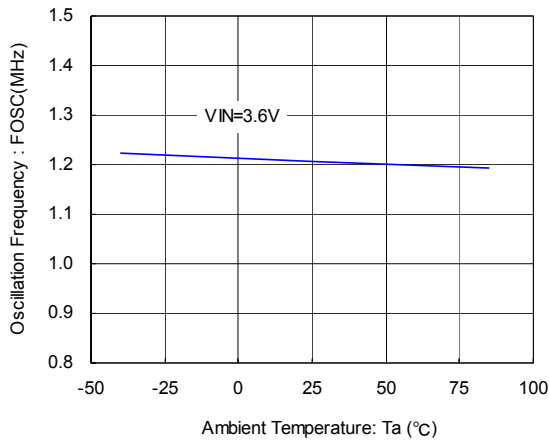

$V_{OUT}=1.8V, 3.0MHz$

$L=1.5\mu H(NR3015), C_{IN}=4.7\mu F, C_L=10\mu F$



(5) Supply Current vs. Ambient Temperature

$V_{OUT}=1.8V, 1.2MHz$

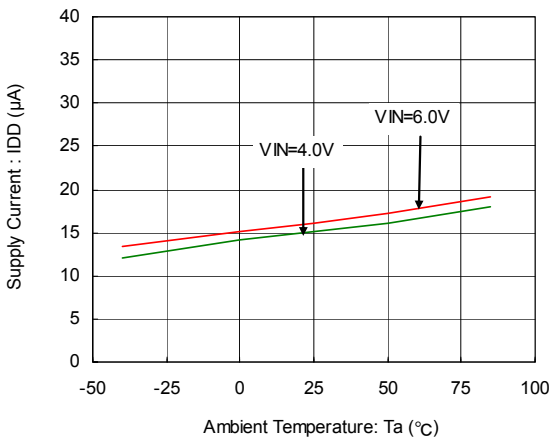

$V_{OUT}=1.8V, 3.0MHz$



(6) Output Voltage vs. Ambient Temperature

$V_{OUT}=1.8V, 3.0MHz$

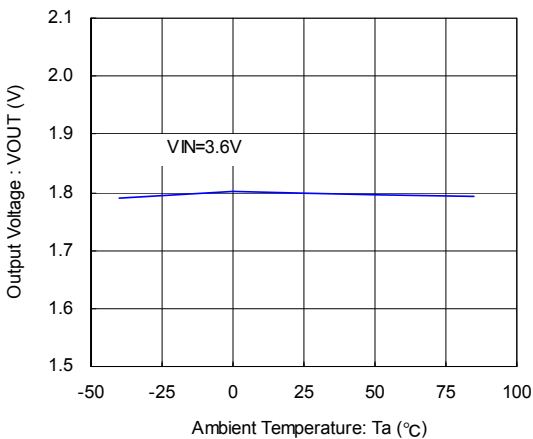

(7) UVLO Voltage vs. Ambient Temperature

$V_{OUT}=1.8V, 3.0MHz$

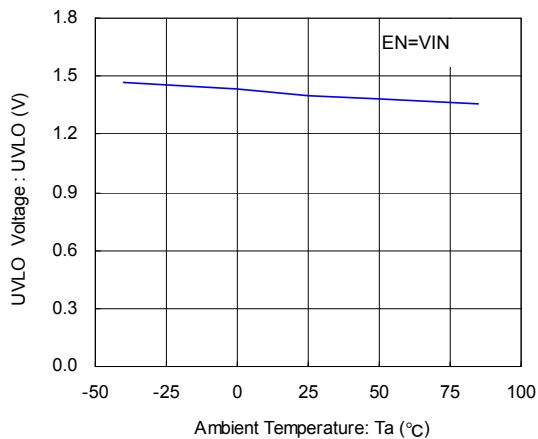

TYPICAL PERFORMANCE CHARACTERISTICS (Continued)

(8) CE "H" Voltage vs. Ambient Temperature
 $V_{OUT}=1.8V, 3.0MHz$



(9) CE "L" Voltage vs. Ambient Temperature
 $V_{OUT}=1.8V, 3.0MHz$



(10) Soft Start Time vs. Ambient Temperature
 $V_{OUT}=1.8V, 3.0MHz$

$L=4.7 \mu H$ (NR4018), $C_{IN}=4.7 \mu F$, $C_L=10 \mu F$



$V_{OUT}=1.8V, 3.0MHz$

$L=1.5 \mu H$ (NR3015), $C_{IN}=4.7 \mu F$, $C_L=10 \mu F$

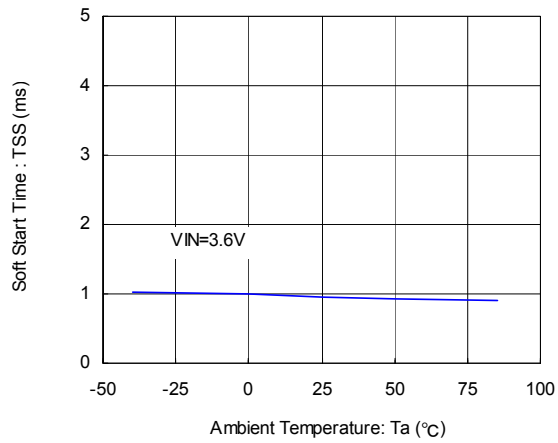

(11) "Pch / Nch" Driver on Resistance vs. Input Voltage
 $V_{OUT}=1.8V, 3.0MHz$



TYPICAL PERFORMANCE CHARACTERISTICS (Continued)

(12) XCM517BxSeries Rise Wave Form



(13) XCM517BxSeries Soft-Start Time vs. Ambient Temperature



(14) XCM517BxSeries CL Discharge Resistance vs. Ambient Temperature



TYPICAL PERFORMANCE CHARACTERISTICS (Continued)

(15) Load Transient Response

$V_{OUT}=1.2V$, 1.2MHz (PWM/PFM Automatic Switching Control)

$L=4.7\ \mu H$ (NR4018), $C_{IN}=4.7\ \mu F$ (ceramic), $C_L=10\ \mu F$ (ceramic), $T_{opr}=25$

$V_{IN}=3.6V$, $EN=V_{IN}$



TYPICAL PERFORMANCE CHARACTERISTICS (Continued)

(15) Load Transient Response (Continued)

$V_{OUT}=1.2V$, 1.2MHz (PWM Control)

$L=4.7\ \mu H$ (NR4018), $C_{IN}=4.7\ \mu F$ (ceramic), $C_L=10\ \mu F$ (ceramic), $T_{opr}=25$

$V_{IN}=3.6V$, $EN=V_{IN}$

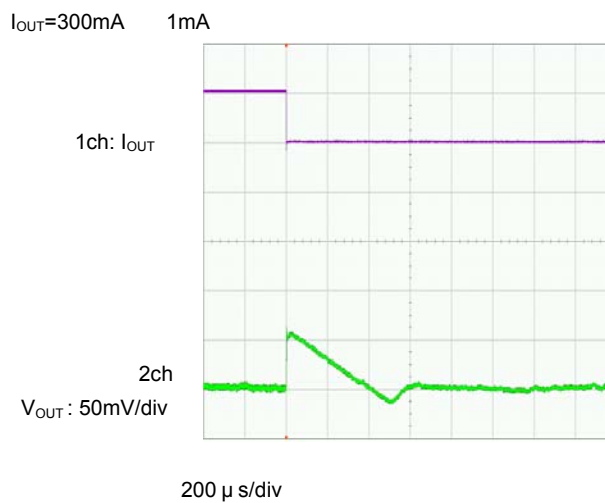
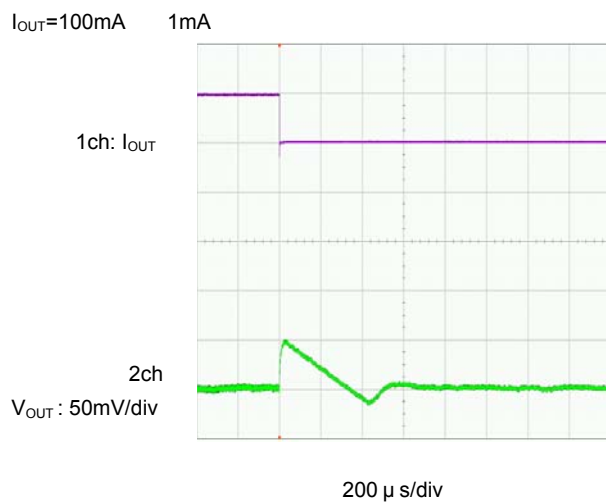
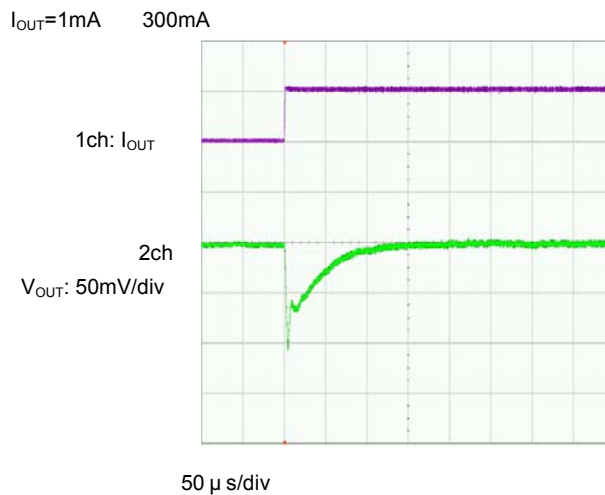
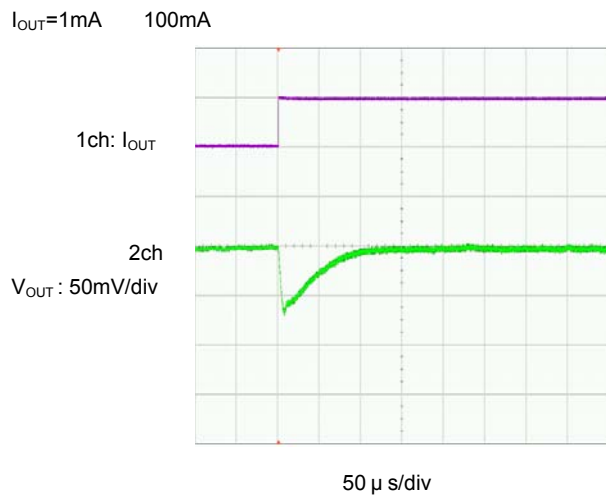

TYPICAL PERFORMANCE CHARACTERISTICS (Continued)

(15) Load Transient Response (Continued)

$V_{OUT}=1.8V$, 3.0MHz (PWM/PFM Automatic Switching Control)

$L=1.5\ \mu H$ (NR3015), $C_{IN}=4.7\ \mu F$ (ceramic), $C_L=10\ \mu F$ (ceramic), $T_{opr}=25$

$V_{IN}=3.6V$, $EN=V_{IN}$

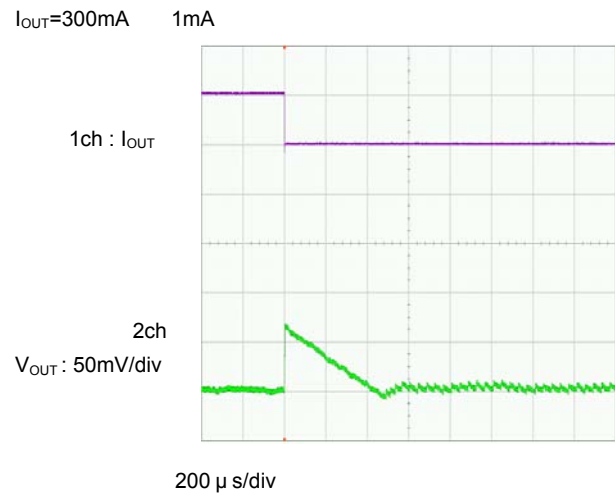
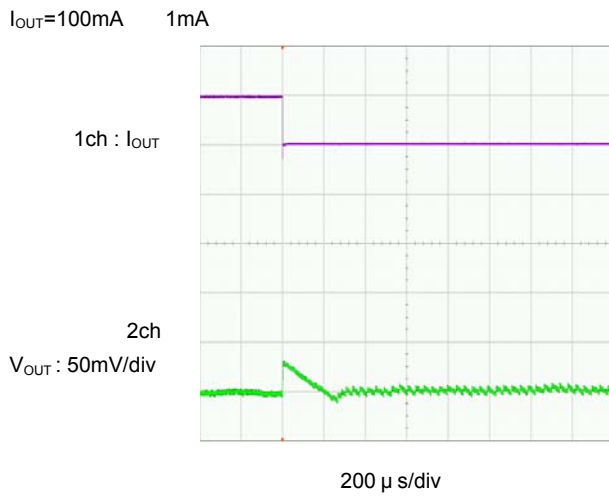
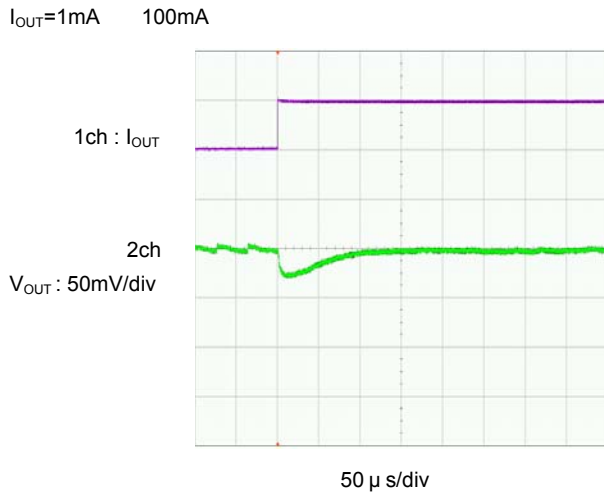

TYPICAL PERFORMANCE CHARACTERISTICS (Continued)

(15) Load Transient Response (Continued)

$V_{OUT}=1.8V$, 3.0MHz (PWM Control)

$L=1.5\ \mu H$ (NR3015), $C_{IN}=4.7\ \mu F$ (ceramic), $C_L=10\ \mu F$ (ceramic), $T_{opr}=25$

$V_{IN}=3.6V$, $EN=V_{IN}$

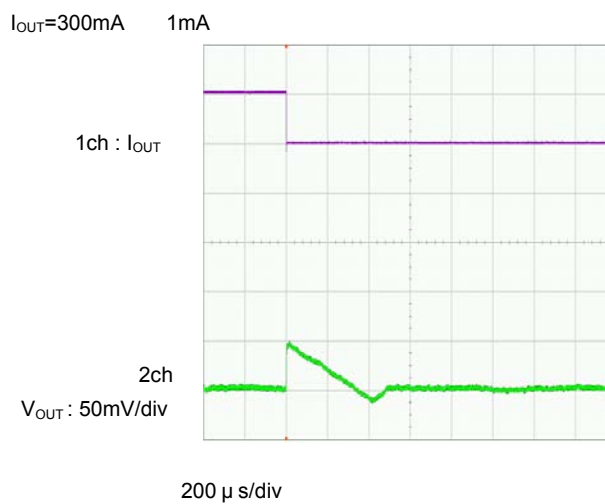
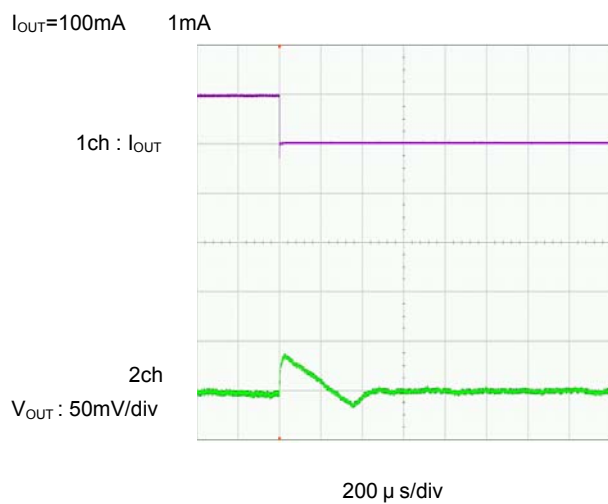
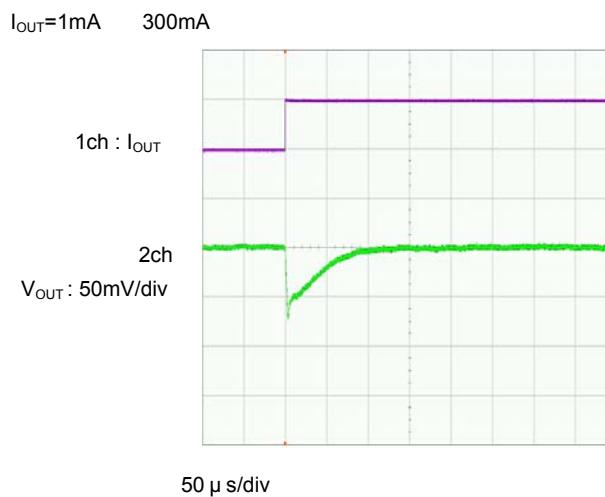
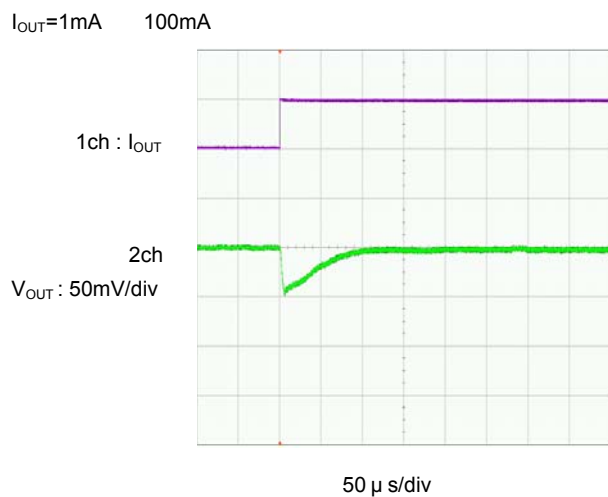

PACKAGING INFORMATION

USP-12B01

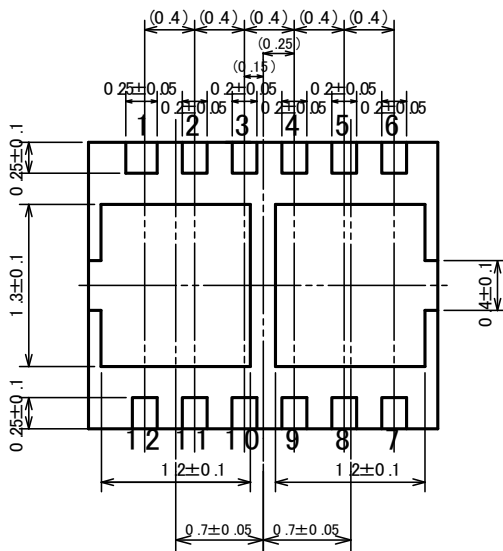

* Au plate thickness: Minimum 0.3 μm

*The side of pins is not plated, nickel is exposed.

*Pin #1 is wider than other pins.

UNIT: mm

USP-12B01 Reference Pattern Layout

USP-12B01 Reference Metal Mask Design

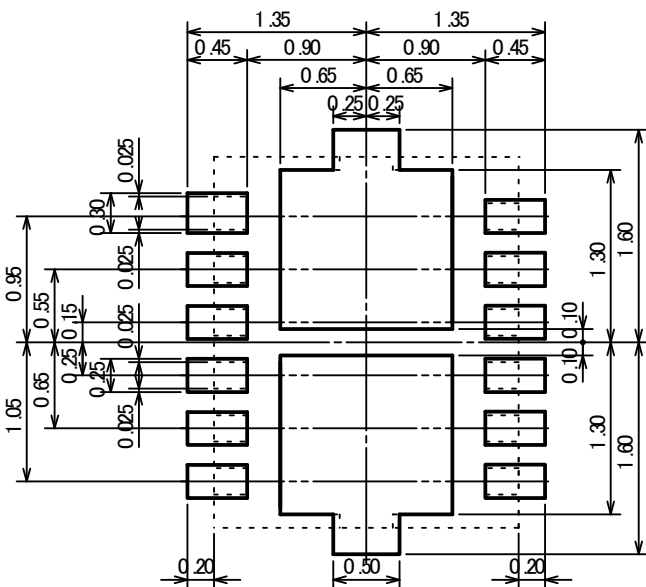

1. The products and product specifications contained herein are subject to change without notice to improve performance characteristics. Consult us, or our representatives before use, to confirm that the information in this datasheet is up to date.
2. We assume no responsibility for any infringement of patents, patent rights, or other rights arising from the use of any information and circuitry in this datasheet.
3. Please ensure suitable shipping controls (including fail-safe designs and aging protection) are in force for equipment employing products listed in this datasheet.
4. The products in this datasheet are not developed, designed, or approved for use with such equipment whose failure or malfunction can be reasonably expected to directly endanger the life of, or cause significant injury to, the user.
(e.g. Atomic energy; aerospace; transport; combustion and associated safety equipment thereof.)
5. Please use the products listed in this datasheet within the specified ranges.
Should you wish to use the products under conditions exceeding the specifications, please consult us or our representatives.
6. We assume no responsibility for damage or loss due to abnormal use.
7. All rights reserved. No part of this datasheet may be copied or reproduced without the prior permission of TOREX SEMICONDUCTOR LTD.

TOREX SEMICONDUCTOR LTD.



Компания «ЭлектроПласт» предлагает заключение долгосрочных отношений при поставках импортных электронных компонентов на взаимовыгодных условиях!

Наши преимущества:

- Оперативные поставки широкого спектра электронных компонентов отечественного и импортного производства напрямую от производителей и с крупнейших мировых складов;
- Поставка более 17-ти миллионов наименований электронных компонентов;
- Поставка сложных, дефицитных, либо снятых с производства позиций;
- Оперативные сроки поставки под заказ (от 5 рабочих дней);
- Экспресс доставка в любую точку России;
- Техническая поддержка проекта, помощь в подборе аналогов, поставка прототипов;
- Система менеджмента качества сертифицирована по Международному стандарту ISO 9001;
- Лицензия ФСБ на осуществление работ с использованием сведений, составляющих государственную тайну;
- Поставка специализированных компонентов (Xilinx, Altera, Analog Devices, Intersil, Interpoint, Microsemi, Aeroflex, Peregrine, Syfer, Eurofarad, Texas Instrument, Miteq, Cobham, E2V, MA-COM, Hittite, Mini-Circuits, General Dynamics и др.);

Помимо этого, одним из направлений компании «ЭлектроПласт» является направление «Источники питания». Мы предлагаем Вам помощь Конструкторского отдела:

- Подбор оптимального решения, техническое обоснование при выборе компонента;
- Подбор аналогов;
- Консультации по применению компонента;
- Поставка образцов и прототипов;
- Техническая поддержка проекта;
- Защита от снятия компонента с производства.



Как с нами связаться

Телефон: 8 (812) 309 58 32 (многоканальный)

Факс: 8 (812) 320-02-42

Электронная почта: org@eplast1.ru

Адрес: 198099, г. Санкт-Петербург, ул. Калинина, дом 2, корпус 4, литера А.