



DATA-CON-X™: SEALED USB TYPE A & B CONNECTORS

NEW PRODUCT BULLETIN C711

CONXALL®

A SWITCHCRAFT COMPANY



CONXALL • 601 E Wildwood • Villa Park, IL 60181 • 630-834-7504
Please visit conxall.com for the most up-to-date product specifications. Made in the USA.

DATA-CON-X™: SEALED USB TYPE A & B CONNECTORS

NEW PRODUCT BULLETIN C711



FEATURES & BENEFITS

- Sealed to IP67 & IP68 NEMA 250 (6P) (when mated)
- Feed-thru termination on the panel for easy field installation
- Field installable design is easy to assemble
- Quick connect bayonet or threaded style interface
- RoHS compliant assembly
- UV F1 rated housing

APPLICATIONS

- Any sealed data transmission
- Military or industrial GPS location devices
- Instrumentation
- Medical data carts
- Data acquisition units
- General industrial electronic applications



CONXALL • 601 E Wildwood • Villa Park, IL 60181 • 630-834-7504
Please visit conxall.com for the most up-to-date product specifications. Made in the USA.

DATA-CON-X™: SEALED USB TYPE A & B CONNECTORS

NEW PRODUCT BULLETIN C711

SPECIFICATIONS

MECHANICAL SPECIFICATIONS

Life:	Minimum 350 insertion/withdrawal cycles
Hex Nut Torque:	10-12 in-lb max
Coupling Locking Style:	Quick Connect (Bayonet) or Threaded
Backshell Style:	Threaded Nut-Squeezed Grommet

ELECTRICAL SPECIFICATIONS

Current Rating:	1.5 A
Voltage Rating:	Per USB 2.0 standard
Contact Resistance:	30 mΩ max
Insulation Resistance:	1000 MΩ min
Dielectric Withstanding Voltage:	500 V AC/one minute

ENVIRONMENTAL SPECIFICATIONS

Operating Temperature Rating:	0 °C to +50 °C (+32°F to +122°F)
Storage Temperature:	-20 °C to +60 °C (-4°F to +140°F)
Moisture Resistance:	Mil-Std 202G Method 106G
Insulation Resistance:	Mil-Std 202G Method 302
Vibration:	Mil-Std 202G Method 201A
Thermal Shock:	Mil-Std 202G Method 107G
Weathertight:	IP67 & IP68, NEMA 250 (6P) (when mated)
Salt Spray:	Mil-Std 202G Method 101E
Product Ratings:	Tested per USB 2.0

MATERIAL SPECIFICATIONS

Plug Nut, Coupling Ring:	Thermoplastic
Plug Housing, Insert:	Thermoplastic
Sealing Ring, O-Ring:	Elastomer
Panel Housing, Hex Nut:	Thermoplastic
Retaining Nut:	Copper Alloy, Nickel Plated
Gasket:	Elastomer
USB A or B Plug:	
Shell:	Steel, Nickel Plated
Contacts:	Copper Alloy, Gold Plated
Insulator:	Thermoplastic UL94V-0, White

USB A Receptacle:

Shell:	Steel, Nickel Plated
Contacts:	Copper Alloy, Gold Plated
Insulator:	Thermoplastic UL94V-0, White

USB B Receptacle:

Shell:	Copper Alloy, Nickel Plated
Contacts:	Copper Alloy, Gold Plated
Insulator:	Thermoplastic UL94V-0, White

MOLDED CABLE ASSEMBLIES

Consult factory for molded options

OTHER

Flame Rating:	UL 94V-0
Recommended Panel Thickness:	1/32" - 3/16" [0.8mm to 4.8mm] - Quick Connect Coupling 1/32" - 5/32" [0.8mm to 3.9mm] - Threaded Coupling

Recommended Cable Type

Conductor Type:	Solid or Stranded Conductors
Outer Cable O.D. Range:	Product 150 Series: 0.134"-0.170" [3.40mm-4.33mm] Product 180 Series: 0.171"-0.208" [4.34mm-5.28mm]



CONXALL • 601 E Wildwood • Villa Park, IL 60181 • 630-834-7504

Please visit conxall.com for the most up-to-date product specifications. Made in the USA.

DATA-CON-X™: SEALED USB TYPE A & B CONNECTORS

NEW PRODUCT BULLETIN C711



USB A FIELD INSTALLABLE CABLE PLUG
(SHOWN WITH QUICK CONNECT COUPLING)

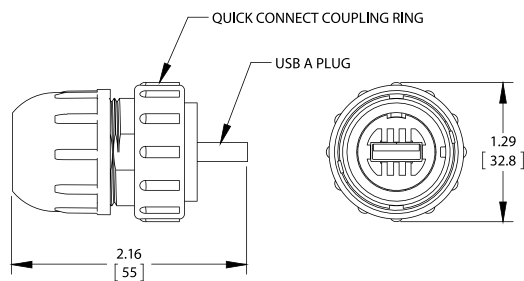

USB B FIELD INSTALLABLE CABLE PLUG
(SHOWN WITH THREADED COUPLING)

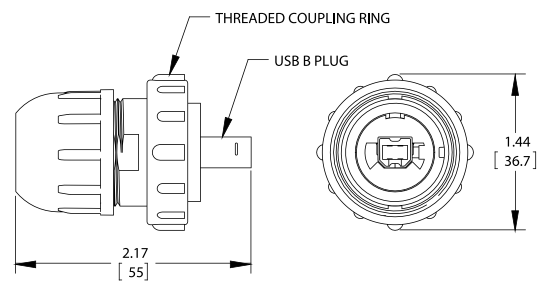

USB PANEL MOUNT FEED-THRU CONNECTOR
(SHOWN WITH USB A TO B FEED-THRU CONNECTOR)
(SHOWN WITH THREADED HOUSING)



USB PANEL MOUNT FEED-THRU CONNECTOR
(SHOWN WITH USB B TO A FEED-THRU CONNECTOR)
(SHOWN WITH QUICK CONNECT HOUSING)

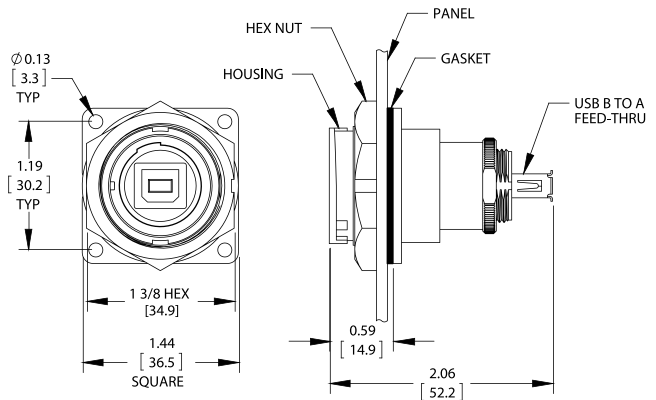

USB FIELD INSTALLABLE CABLE PLUG PART NUMBER CHART

USB FIELD INSTALLABLE CABLE PLUG ASSEMBLY	PLUG TYPE	COUPLING TYPE	SERIES
DCC	USBA = USB "A" 2.0 USBB = USB "B" 2.0	B = QUICK CONNECT T = THREADED	150 = Ø0.134-0.170 [3.40-4.33MM] 180 = Ø0.171-0.208 [4.34-5.28MM]

USB PANEL MOUNT FEED-THRU CONNECTORS PART NUMBER CHART

USB FIELD INSTALLABLE PANEL HOUSING ASSEMBLY	RECEPTACLE TYPE (SEALED END)	COUPLING TYPE	RECEPTACLE TYPE (NON-SEALED END)
DCP	USBA = USB "A" 2.0 USBB = USB "B" 2.0	B = QUICK CONNECT T = THREADED	USBA = USB "A" 2.0 (NOT AVAILABLE WITH USBA ON SEALED END) USBB = USB "B" 2.0 (NOT AVAILABLE WITH USBB ON SEALED END)



DATA-CON-X™: SEALED USB TYPE A & B CONNECTORS

NEW PRODUCT BULLETIN C711

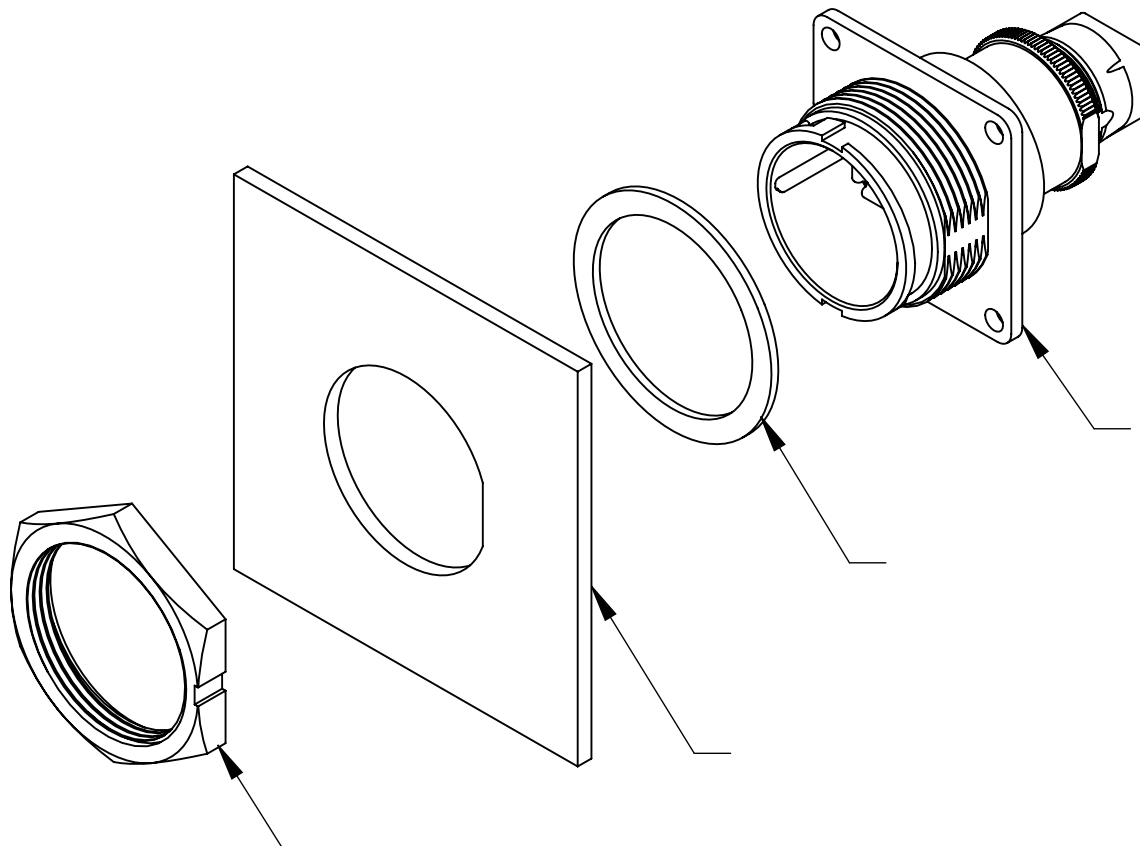

NOTES:

1. DCP-USBAB-USBB SHOWN IN EXPLODED VIEW. (USB A TO B WITH QUICK CONNECT COUPLING.)
2. MATED ASSEMBLY MEETS IP-67 & IP-68, NEMA 250 (6P).
3. THESE ASSEMBLIES ARE RoHS COMPLIANT.

MATERIALS:

GASKET: ELASTOMER
HEX NUT: THERMOPLASTIC
USB PANEL HOUSING: THERMOPLASTIC
RETAINING NUT: COPPER ALLOY, NICKEL PLATED
USB A RECEPTACLE:
SHELL: STEEL, NICKEL PLATED
CONTACTS: COPPER ALLOY, GOLD PLATED
INSULATOR: THERMOPLASTIC
USB B RECEPTACLE:
SHELL: COPPER ALLOY, NICKEL PLATED
CONTACTS: COPPER ALLOY, GOLD PLATED
INSULATOR: THERMOPLASTIC

OTHER:

RECOMMENDED PANEL THICKNESS:
QUICK CONNECT COUPLING: 1/32" TO 3/16" (0.8mm to 4.8mm)
THREADED COUPLING: 1/32" TO 5/32" (0.8mm to 3.9mm)



CONXALL • 601 E Wildwood • Villa Park, IL 60181 • 630-834-7504
Please visit conxall.com for the most up-to-date product specifications. Made in the USA.

DATA-CON-X™: SEALED USB TYPE A & B CONNECTORS

NEW PRODUCT BULLETIN C711



NOTES:

DCC-USBAB-180 SHOWN IN EXPLODED VIEW. (USB TYPE A WITH QUICK CONNECT COUPLING.)

MATERIALS:

PLUG HOUSING: THERMOPLASTIC
SEALING NUT, COUPLING RING: THERMOPLASTIC
SEALING RING: ELASTOMER
O-RING: ELASTOMER
INSERT: THERMOPLASTIC
USB PLUG:
INSULATOR: THERMOPLASTIC
CONTACTS: COPPER ALLOY, GOLD PLATED
SHIELD: COPPER ALLOY, TIN PLATED

ELECTRICAL:

VOLTAGE RATING: PER USB 2.0 STANDARD
CONTACT RESISTANCE: 30 MILLIOHMS MAXIMUM
CONTACT CURRENT RATING: 1.5 A MINIMUM
INSULATION RESISTANCE: 1000 MEGAOHMS MINIMUM
WITHSTANDING VOLTAGE: 500VAC FOR 1 MINUTE

PRODUCT RATING:

IP67 & IP68, NEMA 250 (6P) WHEN MATED
USB A PLUG: USB 2.0
USB B PLUG: USB 2.0

OTHER:

OPERATING TEMPERATURE: 0 °C TO +50 °C
RECOMMENDED CABLE TYPE: SOLID OR STRANDED CONDUCTORS
OUTER CABLE O.D. RANGE:
PRODUCT 150 SERIES: 0.134-0.170 [3.40mm-4.33mm]
PRODUCT 180 SERIES: 0.171-0.208 [4.34mm-5.28mm]





Компания «ЭлектроПласт» предлагает заключение долгосрочных отношений при поставках импортных электронных компонентов на взаимовыгодных условиях!

Наши преимущества:

- Оперативные поставки широкого спектра электронных компонентов отечественного и импортного производства напрямую от производителей и с крупнейших мировых складов;
- Поставка более 17-ти миллионов наименований электронных компонентов;
- Поставка сложных, дефицитных, либо снятых с производства позиций;
- Оперативные сроки поставки под заказ (от 5 рабочих дней);
- Экспресс доставка в любую точку России;
- Техническая поддержка проекта, помощь в подборе аналогов, поставка прототипов;
- Система менеджмента качества сертифицирована по Международному стандарту ISO 9001;
- Лицензия ФСБ на осуществление работ с использованием сведений, составляющих государственную тайну;
- Поставка специализированных компонентов (Xilinx, Altera, Analog Devices, Intersil, Interpoint, Microsemi, Aeroflex, Peregrine, Syfer, Eurofarad, Texas Instrument, Miteq, Cobham, E2V, MA-COM, Hittite, Mini-Circuits, General Dynamics и др.);

Помимо этого, одним из направлений компании «ЭлектроПласт» является направление «Источники питания». Мы предлагаем Вам помощь Конструкторского отдела:

- Подбор оптимального решения, техническое обоснование при выборе компонента;
- Подбор аналогов;
- Консультации по применению компонента;
- Поставка образцов и прототипов;
- Техническая поддержка проекта;
- Защита от снятия компонента с производства.



Как с нами связаться

Телефон: 8 (812) 309 58 32 (многоканальный)

Факс: 8 (812) 320-02-42

Электронная почта: org@eplast1.ru

Адрес: 198099, г. Санкт-Петербург, ул. Калинина, дом 2, корпус 4, литера А.